



# SMB10(8)J5.0(C) thru SMB10(8)J40(C)A

Vishay General Semiconductor

## High Power Density Surface Mount TRANSZORB® Transient Voltage Suppressors



DO-214AA (SMB)

### FEATURES

- Low profile package
- Ideal for automated placement
- Glass passivated chip junction
- Available in uni-directional and bi-directional
- Excellent clamping capability
- Very fast response time
- Low incremental surge resistance
- Meets MSL level 1, per J-STD-020, LF maximum peak of 260 °C
- Solder dip 260 °C, 40 s
- Component in accordance to RoHS 2002/95/EC and WEEE 2002/96/EC



RoHS  
COMPLIANT

### TYPICAL APPLICATIONS

Use in sensitive electronics protection against voltage transients induced by inductive load switching and lighting on ICs, MOSFET, signal lines of sensor units for consumer, computer, industrial, automotive and telecommunication.

PRIMARY CHARACTERISTICS	
$V_{WM}$	5.0 V to 40 V
$P_{PPM}$ (uni-directional)	1000 W
$P_{PPM}$ (bi-directional)	800 W
$I_{FSM}$ (uni-directional only)	100 A
$T_J$ max.	150 °C

### MECHANICAL DATA

**Case:** DO-214AA (SMBJ)

Molding compound meets UL 94 V-0 flammability rating

Base P/N-E3 - RoHS compliant, commercial grade

Base P/NHE3 - RoHS compliant, high reliability/automotive grade (AEC Q101 qualified)

**Terminals:** Matte tin plated leads, solderable per J-STD-002 and JESD22-B102

E3 suffix meets JESD 201 class 1A whisker test, HE3 suffix meets JESD 201 class 2 whisker test

**Polarity:** For uni-directional types the color band denotes cathode end, no marking on bi-directional types

MAXIMUM RATINGS ( $T_A = 25\text{ °C}$ unless otherwise noted)			
PARAMETER	SYMBOL	VALUE	UNIT
Peak pulse power dissipation with a 10/1000 $\mu$ s waveform <sup>(1)(2)</sup> (Fig. 1)	$P_{PPM}$	1000 800	W
Peak pulse current with a 10/1000 $\mu$ s waveform <sup>(1)</sup>	$I_{PPM}$	See next table	A
Peak forward surge current 8.3 ms single half sine-wave uni-directional only <sup>(2)</sup>	$I_{FSM}$	100	A
Operating junction and storage temperature range	$T_J, T_{STG}$	- 55 to + 150	°C

#### Notes:

(1) Non-repetitive current pulse, per Fig. 3 and derated above  $T_A = 25\text{ °C}$  per Fig. 2

(2) Mounted on 0.2 x 0.2" (5.0 x 5.0 mm) copper pads to each terminal

# SMB10(8)J5.0(C) thru SMB10(8)J40(C)A



Vishay General Semiconductor

## UNI-DIRECTIONAL

ELECTRICAL CHARACTERISTICS (T <sub>A</sub> = 25 °C unless otherwise noted)								
DEVICE TYPE	DEVICE MARKING CODE	BREAKDOWN VOLTAGE V <sub>BR</sub> AT I <sub>T</sub> <sup>(1)</sup> (V)		TEST CURRENT I <sub>T</sub> (mA)	STAND-OFF VOLTAGE V <sub>WM</sub> (V)	MAXIMUM REVERSE LEAKAGE AT V <sub>WM</sub> I <sub>D</sub> (μA)	MAXIMUM PEAK PULSE SURGE CURRENT I <sub>PPM</sub> (A) <sup>(2)</sup>	MAXIMUM CLAMPING VOLTAGE AT I <sub>PPM</sub> V <sub>C</sub> (V)
		MIN.	MAX.					
SMB10J5.0	1AD	6.40	7.82	10	5.0	1000	104.2	9.6
SMB10J5.0A	1AE	6.40	7.07	10	5.0	1000	108.7	9.2
SMB10J6.0	1AF	6.67	8.15	10	6.0	1000	87.7	11.4
SMB10J6.0A	1AG	6.67	7.37	10	6.0	1000	97.1	10.3
SMB10J6.5	1AH	7.22	8.82	10	6.5	500	81.3	12.3
SMB10J6.5A	1AK	7.22	7.98	10	6.5	500	89.3	11.2
SMB10J7.0	1AL	7.78	9.51	10	7.0	200	75.2	13.3
SMB10J7.0A	1AM	7.78	8.60	10	7.0	200	83.3	12.0
SMB10J7.5	1AN	8.33	10.2	1.0	7.5	100	69.9	14.3
SMB10J7.5A	1AP	8.33	9.21	1.0	7.5	100	77.5	12.9
SMB10J8.0	1AQ	8.89	10.9	1.0	8.0	50	66.7	15.0
SMB10J8.0A	1AR	8.89	9.83	1.0	8.0	50	73.5	13.6
SMB10J8.5	1AS	9.44	11.5	1.0	8.5	20	62.9	15.9
SMB10J8.5A	1AT	9.44	10.4	1.0	8.5	20	69.4	14.4
SMB10J9.0	1AU	10.0	12.2	1.0	9.0	10	59.2	16.9
SMB10J9.0A	1AV	10.0	11.1	1.0	9.0	10	64.9	15.4
SMB10J10	1AW	11.1	13.6	1.0	10	5.0	53.2	18.8
SMB10J10A	1AX	11.1	12.3	1.0	10	5.0	58.8	17.0
SMB10J11	1AY	12.2	14.9	1.0	11	5.0	49.8	20.1
SMB10J11A	1AZ	12.2	13.5	1.0	11	5.0	54.9	18.2
SMB10J12	1BD	13.3	16.3	1.0	12	5.0	45.5	22.0
SMB10J12A	1BE	13.3	14.7	1.0	12	5.0	50.3	19.9
SMB10J13	1BF	14.4	17.6	1.0	13	1.0	42.0	23.8
SMB10J13A	1BG	14.4	15.9	1.0	13	1.0	46.5	21.5
SMB10J14	1BH	15.6	19.1	1.0	14	1.0	38.8	25.8
SMB10J14A	1BK	15.6	17.2	1.0	14	1.0	43.1	23.2
SMB10J15	1BL	16.7	20.4	1.0	15	1.0	37.2	26.9
SMB10J15A	1BM	16.7	18.5	1.0	15	1.0	41.0	24.4
SMB10J16	1BN	17.8	21.8	1.0	16	1.0	34.7	28.8
SMB10J16A	1BP	17.8	19.7	1.0	16	1.0	38.5	26.0
SMB10J17	1BQ	18.9	23.1	1.0	17	1.0	32.8	30.5
SMB10J17A	1BR	18.9	20.9	1.0	17	1.0	36.2	27.6
SMB10J18	1BS	20.0	24.4	1.0	18	1.0	31.1	32.2
SMB10J18A	1BT	20.0	22.1	1.0	18	1.0	34.2	29.2
SMB10J20	1BU	22.2	27.1	1.0	20	1.0	27.9	35.8
SMB10J20A	1BV	22.2	24.5	1.0	20	1.0	30.9	32.4
SMB10J22	1BW	24.4	29.8	1.0	22	1.0	25.4	39.4
SMB10J22A	1BX	24.4	26.9	1.0	22	1.0	28.2	35.5
SMB10J24	1BY	26.7	32.6	1.0	24	1.0	23.3	43.0
SMB10J24A	1BZ	26.7	29.5	1.0	24	1.0	25.7	38.9
SMB10J26	1CD	28.9	35.3	1.0	26	1.0	21.5	46.6
SMB10J26A	1CE	28.9	31.9	1.0	26	1.0	23.8	42.1
SMB10J28	1CF	31.1	38.0	1.0	28	1.0	20.0	50.0
SMB10J28A	1CG	31.1	34.4	1.0	28	1.0	22.0	45.4
SMB10J30	1CH	33.3	40.7	1.0	30	1.0	18.7	53.5
SMB10J30A	1CK	33.3	36.8	1.0	30	1.0	20.7	48.4
SMB10J33	1CL	36.7	44.9	1.0	33	1.0	16.9	59.0
SMB10J33A	1CM	36.7	40.6	1.0	33	1.0	18.8	53.3
SMB10J36	1CN	40.0	48.9	1.0	36	1.0	15.6	64.3
SMB10J36A	1CP	40.0	44.2	1.0	36	1.0	17.2	58.1
SMB10J40	1CQ	44.4	54.3	1.0	40	1.0	14.0	71.4
SMB10J40A	1CR	44.4	49.1	1.0	40	1.0	15.5	64.5

**Notes:**

- (1) Pulse test: t<sub>p</sub> ≤ 50 ms
- (2) Surge current waveform per Fig. 3 and derate per Fig. 2
- (3) All terms and symbols are consistent with ANSI/IEEE C62.35
- (4) V<sub>F</sub> = 3.5 V at I<sub>F</sub> = 50 A (uni-directional only)



# SMB10(8)J5.0(C) thru SMB10(8)J40(C)A

Vishay General Semiconductor

## BI-DIRECTIONAL

ELECTRICAL CHARACTERISTICS (T <sub>A</sub> = 25 °C unless otherwise noted)								
DEVICE TYPE	DEVICE MARKING CODE	BREAKDOWN VOLTAGE V <sub>BR</sub> <sup>(1)</sup> (V)		TEST CURRENT AT I <sub>T</sub> (mA)	STAND-OFF VOLTAGE V <sub>WM</sub> (V)	MAXIMUM REVERSE LEAKAGE AT V <sub>WM</sub> I <sub>D</sub> (μA) <sup>(3)</sup>	MAXIMUM PEAK PULSE SURGE CURRENT I <sub>PPM</sub> (A) <sup>(2)</sup>	MAXIMUM CLAMPING VOLTAGE AT I <sub>PPM</sub> V <sub>C</sub> (V)
		MIN.	MAX.					
SMB8J5.0C	1AD	6.40	7.82	10	5.0	2000	83.3	9.6
SMB8J5.0CA	1AE	6.40	7.25	10	5.0	2000	87.0	9.2
SMB8J6.0C	1AF	6.67	8.15	10	6.0	2000	70.2	11.4
SMB8J6.0CA	1AG	6.67	7.37	10	6.0	2000	77.7	10.3
SMB8J6.5C	1AH	7.22	8.82	10	6.5	1000	65.0	12.3
SMB8J6.5CA	1AK	7.22	7.98	10	6.5	1000	71.4	11.2
SMB8J7.0C	1AL	7.78	9.51	10	7.0	400	60.2	13.3
SMB8J7.0CA	1AM	7.78	8.60	10	7.0	400	66.7	12.0
SMB8J7.5C	1AN	8.33	10.2	1.0	7.5	200	55.9	14.3
SMB8J7.5CA	1AP	8.33	9.21	1.0	7.5	200	62.0	12.9
SMB8J8.0C	1AQ	8.89	10.9	1.0	8.0	100	53.3	15.0
SMB8J8.0CA	1AR	8.89	9.83	1.0	8.0	100	58.8	13.6
SMB8J8.5C	1AS	9.44	11.5	1.0	8.5	40	50.3	15.9
SMB8J8.5CA	1AT	9.44	10.4	1.0	8.5	40	55.6	14.4
SMB8J9.0C	1AU	10.0	12.2	1.0	9.0	20	47.3	16.9
SMB8J9.0CA	1AV	10.0	11.1	1.0	9.0	20	51.9	15.4
SMB8J10C	1AW	11.1	13.6	1.0	10	10	42.6	18.8
SMB8J10CA	1AX	11.1	12.3	1.0	10	10	47.1	17.0
SMB8J11C	1AY	12.2	14.9	1.0	11	5.0	39.8	20.1
SMB8J11CA	1AZ	12.2	13.5	1.0	11	5.0	44.0	18.2
SMB8J12C	1BD	13.3	16.3	1.0	12	5.0	36.4	22.0
SMB8J12CA	1BE	13.3	14.7	1.0	12	5.0	40.2	19.9
SMB8J13C	1BF	14.4	17.6	1.0	13	1.0	33.6	23.8
SMB8J13CA	1BG	14.4	15.9	1.0	13	1.0	37.2	21.5
SMB8J14C	1BH	15.6	19.1	1.0	14	1.0	31.0	25.8
SMB8J14CA	1BK	15.6	17.2	1.0	14	1.0	34.5	23.2
SMB8J15C	1BL	16.7	20.4	1.0	15	1.0	29.7	26.9
SMB8J15CA	1BM	16.7	18.5	1.0	15	1.0	32.8	24.4
SMB8J16C	1BN	17.8	21.8	1.0	16	1.0	27.8	28.8
SMB8J16CA	1BP	17.8	19.7	1.0	16	1.0	30.8	26.0
SMB8J17C	1BQ	18.9	23.1	1.0	17	1.0	26.2	30.5
SMB8J17CA	1BR	18.9	20.9	1.0	17	1.0	29.0	27.6
SMB8J18C	1BS	20.0	24.4	1.0	18	1.0	24.8	32.2
SMB8J18CA	1BT	20.0	22.1	1.0	18	1.0	27.4	29.2
SMB8J20C	1BU	22.2	27.1	1.0	20	1.0	22.3	35.8
SMB8J20CA	1BV	22.2	24.5	1.0	20	1.0	24.7	32.4
SMB8J22C	1BW	24.4	29.8	1.0	22	1.0	20.3	39.4
SMB8J22CA	1BX	24.4	26.9	1.0	22	1.0	22.5	35.5
SMB8J24C	1BY	26.7	32.6	1.0	24	1.0	18.6	43.0
SMB8J24CA	1BZ	26.7	29.5	1.0	24	1.0	20.6	38.9
SMB8J26C	1CD	28.9	35.3	1.0	26	1.0	17.2	46.6
SMB8J26CA	1CE	28.9	31.9	1.0	26	1.0	19.0	42.1
SMB8J28C	1CF	31.1	38.0	1.0	28	1.0	16.0	50.0
SMB8J28CA	1CG	31.1	34.4	1.0	28	1.0	17.6	45.4
SMB8J30C	1CH	33.3	40.7	1.0	30	1.0	15.0	53.5
SMB8J30CA	1CK	33.3	36.8	1.0	30	1.0	16.5	48.4
SMB8J33C	1CL	36.7	44.9	1.0	33	1.0	13.6	59.0
SMB8J33CA	1CM	36.7	40.6	1.0	33	1.0	15.0	53.3
SMB8J36C	1CN	40.0	48.9	1.0	36	1.0	12.4	64.3
SMB8J36CA	1CP	40.0	44.2	1.0	36	1.0	13.8	58.1
SMB8J40C	1CQ	44.4	54.3	1.0	40	1.0	11.2	71.4
SMB8J40CA	1CR	44.4	49.1	1.0	40	1.0	12.4	64.5

### Notes:

- (1) Pulse test: t<sub>p</sub> ≤ 50 ms
- (2) Surge current waveform per Fig. 3 and derate per Fig. 2
- (3) All terms and symbols are consistent with ANSI/IEEE C62.35

# SMB10(8)J5.0(C) thru SMB10(8)J40(C)A

Vishay General Semiconductor



THERMAL CHARACTERISTICS ( $T_A = 25\text{ }^\circ\text{C}$ unless otherwise noted)			
PARAMETER	SYMBOL	VALUE	UNIT
Typical thermal resistance, junction to ambient <sup>(1)</sup>	$R_{\theta JA}$	72	$^\circ\text{C/W}$
Typical thermal resistance, junction to lead	$R_{\theta JL}$	20	$^\circ\text{C/W}$

**Note:**

(1) Mounted on minimum recommended pad layout

ORDERING INFORMATION (Example)				
PREFERRED P/N	UNIT WEIGHT (g)	PREFERRED PACKAGE CODE	BASE QUANTITY	DELIVERY MODE
SMB10J5.0A-E3/52	0.106	52	750	7" diameter plastic tape and reel
SMB10J5.0A-E3/5B	0.106	5B	3200	13" diameter plastic tape and reel
SMB10J5.0AHE3/52 <sup>(1)</sup>	0.106	52	750	7" diameter plastic tape and reel
SMB10J5.0AHE3/5B <sup>(1)</sup>	0.106	5B	3200	13" diameter plastic tape and reel

**Note:**

(1) Automotive grade AEC Q101 qualified

## RATINGS AND CHARACTERISTICS CURVES

( $T_A = 25\text{ }^\circ\text{C}$  unless otherwise noted)

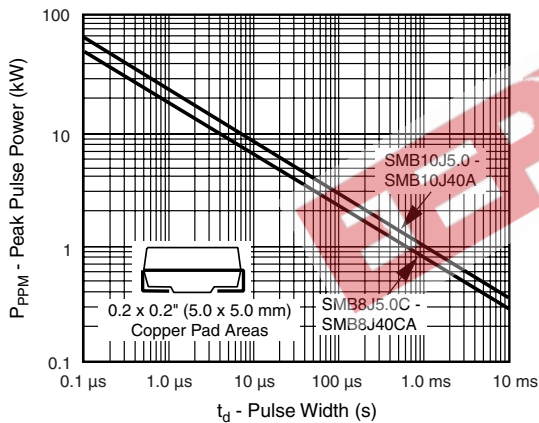

Figure 1. Peak Pulse Power Rating Curve

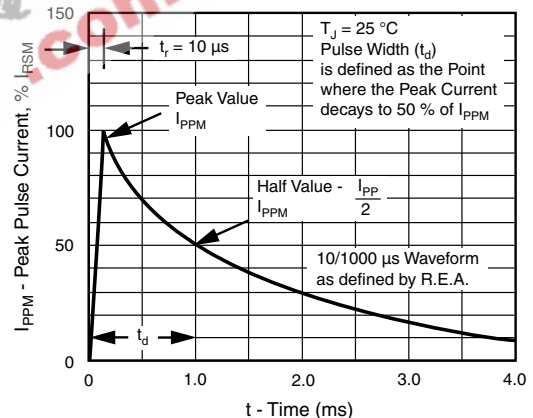

Figure 3. Pulse Waveform

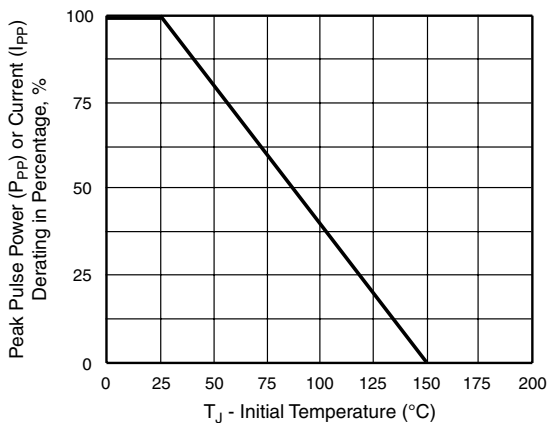

Figure 2. Pulse Power or Current vs. Initial Junction Temperature

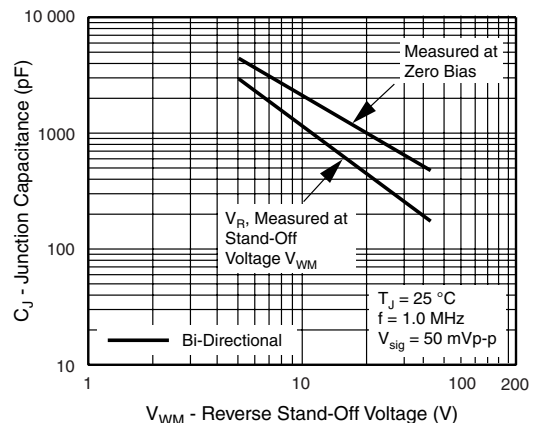

Figure 4. Typical Junction Capacitance



# SMB10(8)J5.0(C) thru SMB10(8)J40(C)A

Vishay General Semiconductor

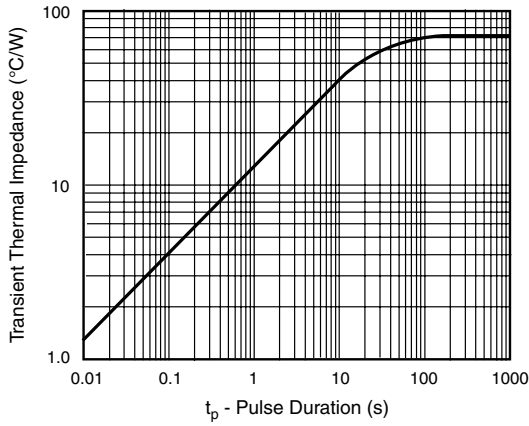

Figure 5. Typical Transient Thermal Impedance

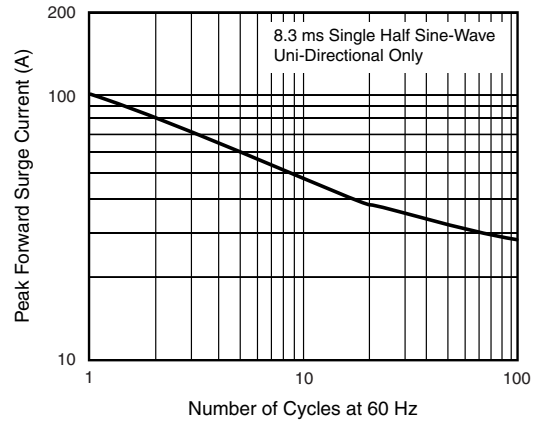
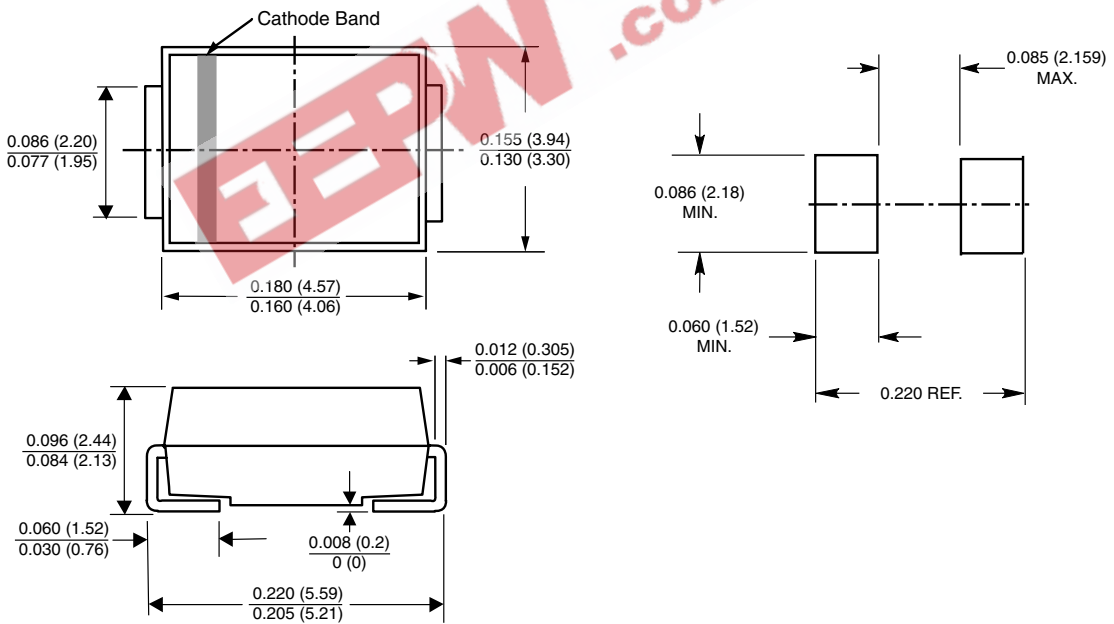

Figure 6. Maximum Non-Repetitive Forward Surge Current

## PACKAGE OUTLINE DIMENSIONS in inches (millimeters)

### DO-214AA (SMB)

### Mounting Pad Layout





### Disclaimer

All product specifications and data are subject to change without notice.

Vishay Intertechnology, Inc., its affiliates, agents, and employees, and all persons acting on its or their behalf (collectively, "Vishay"), disclaim any and all liability for any errors, inaccuracies or incompleteness contained herein or in any other disclosure relating to any product.

Vishay disclaims any and all liability arising out of the use or application of any product described herein or of any information provided herein to the maximum extent permitted by law. The product specifications do not expand or otherwise modify Vishay's terms and conditions of purchase, including but not limited to the warranty expressed therein, which apply to these products.

No license, express or implied, by estoppel or otherwise, to any intellectual property rights is granted by this document or by any conduct of Vishay.

The products shown herein are not designed for use in medical, life-saving, or life-sustaining applications unless otherwise expressly indicated. Customers using or selling Vishay products not expressly indicated for use in such applications do so entirely at their own risk and agree to fully indemnify Vishay for any damages arising or resulting from such use or sale. Please contact authorized Vishay personnel to obtain written terms and conditions regarding products designed for such applications.

Product names and markings noted herein may be trademarks of their respective owners.