

Features

October 2004

- Single chip mixer/oscillator PLL combination for multi band tuner for DTT applications
- Each mixer oscillator band optimized for wide dynamic range
- RF input stages allow for either single-ended or differential drive
- PLL frequency synthesizer designed for low phase noise performance
- Broadband output level detect with onset adjust
- PLL frequency synthesizer compatible with standard digital terrestrial offsets
- Four integrated switching ports
- I²C fast mode compliant
- ESD protection (Normal ESD handling procedures should be observed)

Applications

- Terrestrial digital receiver systems
- Terrestrial analogue receiver systems
- Cable receiver systems
- Data communications systems

Ordering Information

SL2610/IG/LH1Q	40 Pin MLP	Tape & Reel, Bake & Drypack
SL2610/IG/LH1N	40 Pin MLP	Trays, Bake & Drypack
SL2610/IG/LH2Q	40 Pin MLP	Tape & Reel, Bake & Drypack*
SL2610/IG/LH2N	40 Pin MLP	Trays, Bake & Drypack*

*Leadfree

-40°C to +85°C

Description

The SL2610 is a mixer oscillator intended primarily for application in all band tuners, where it performs image reject downconversion of the RF channel to a standard 36 MHz or 44 MHz IF.

Each band consists of a low noise preamplifier/mixer and local oscillator with an external varactor tuned tank. The band outputs share a common low impedance SAWF driver stage.

Frequency selection is controlled by the on-board I²C bus frequency synthesizer. This block also controls four general purpose switching ports for selecting the prefilter/AGC stages.

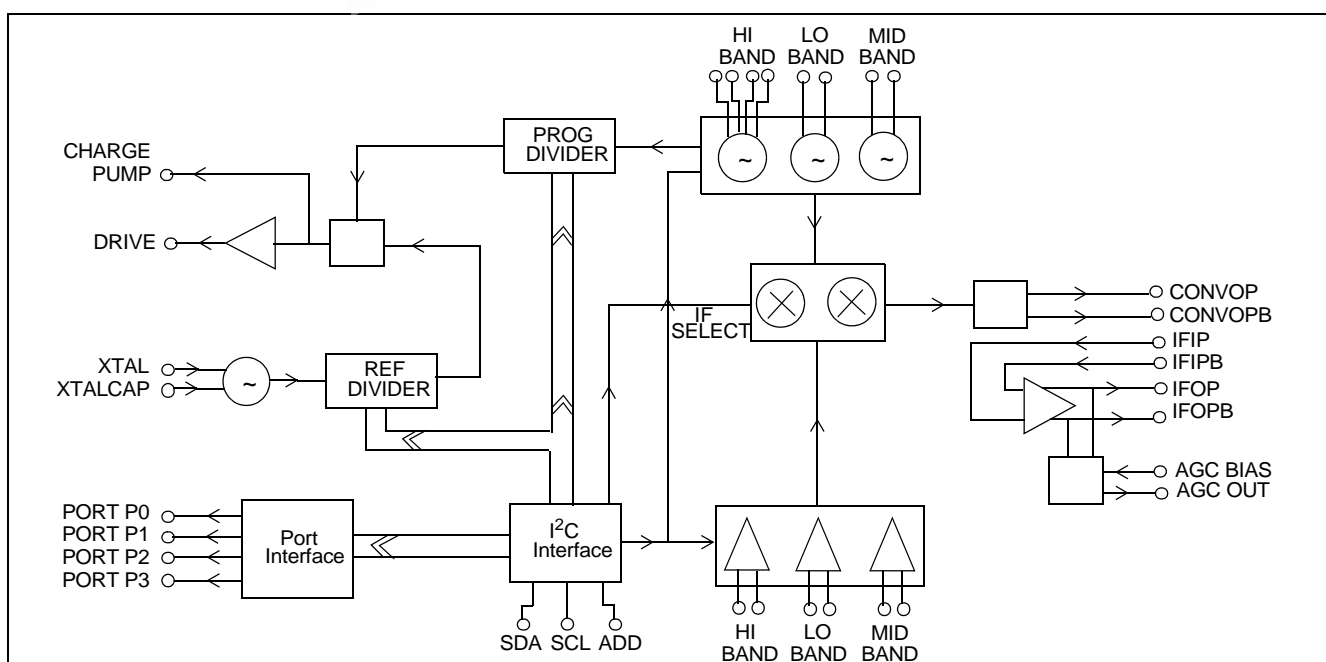

Figure 1 - SL2610 Block Diagram

The SL2610 has high intermodulation intercept performance so offering high signal to spurious performance in the presence of higher amplitude interferers or in the presence of a wide bandwidth composite input signal.

An output broadband level detect circuit is included for control of the tuner front end AGC.

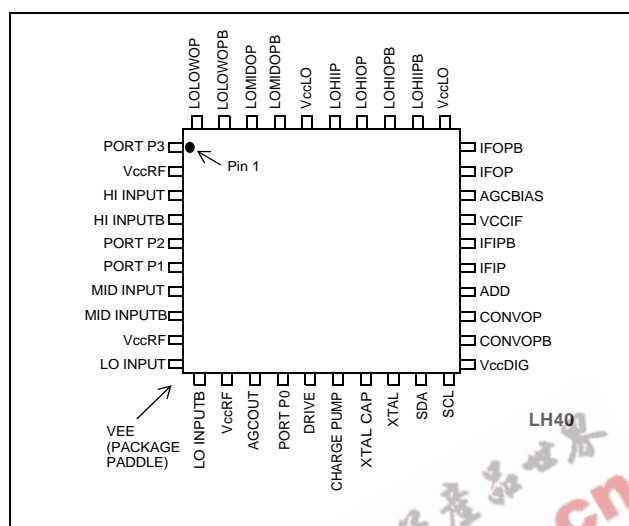

Figure 2 - Pin Allocation Diagram

Quick Reference Data

Characteristics			Units
Frequency range:	LOW band	50-500	MHz
	MID band	50-500	MHz
	HIGH band	200-900	MHz
Conversion gain *		32 ± 2	dB
Noise figure		13	dB
Typical Image Reject		35	dB
P1dB input referred, Converter section only		106	dBuV
IP3 input referred, Converter section only		14	dBm
IP2 input referred, Converter section only		48	dBm
LO phase noise (free running)	@ 10 kHz offset	-90	dBc/Hz
	@ 100 kHz offset	-110	dBc/Hz
PLL phase noise		-158	dBc/Hz
Maximum composite output amplitude		3	dBm

* Assuming 2 dB shaping filter loss in external IF path.

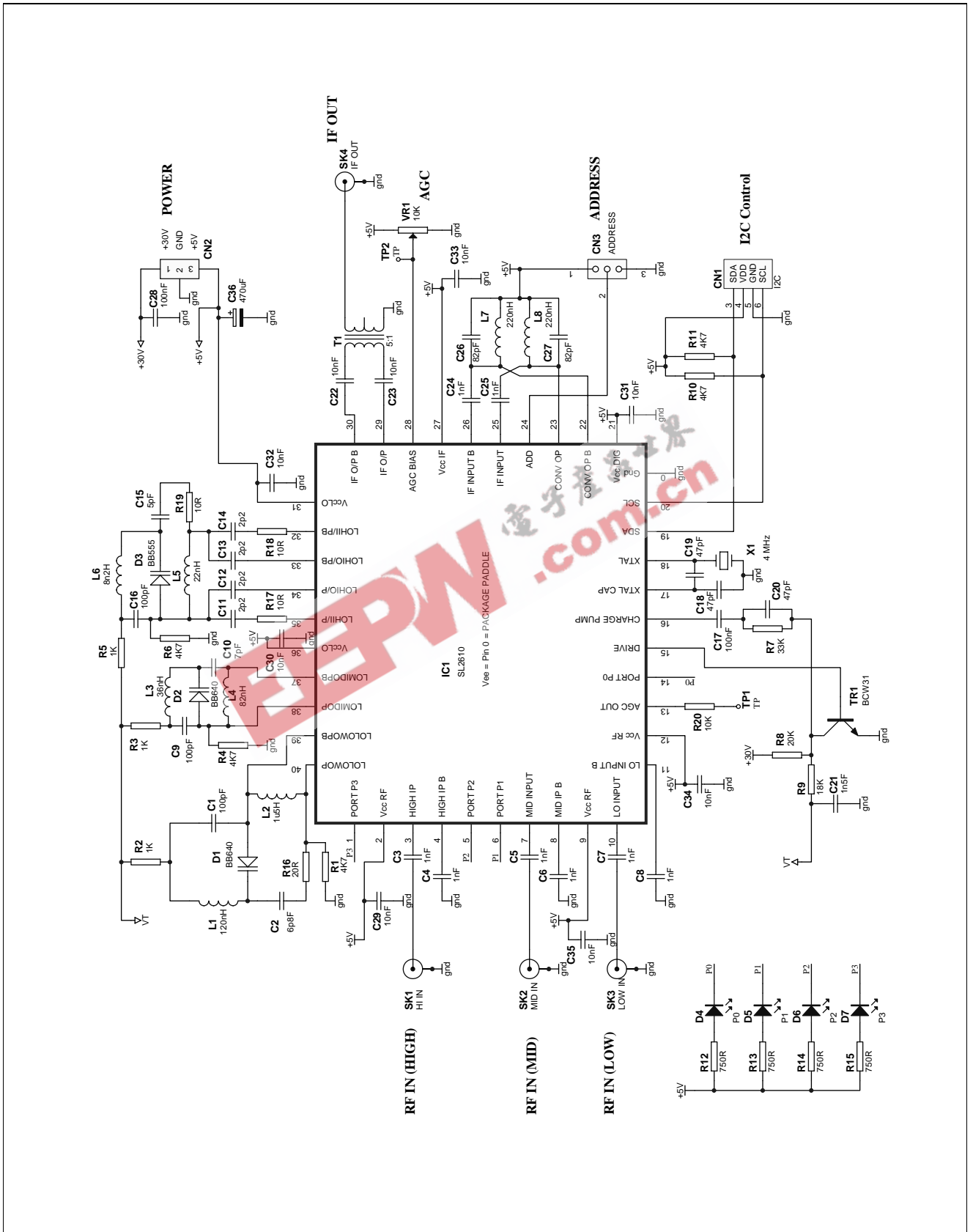

Figure 3 - SL2610 Evaluation Board Schematic

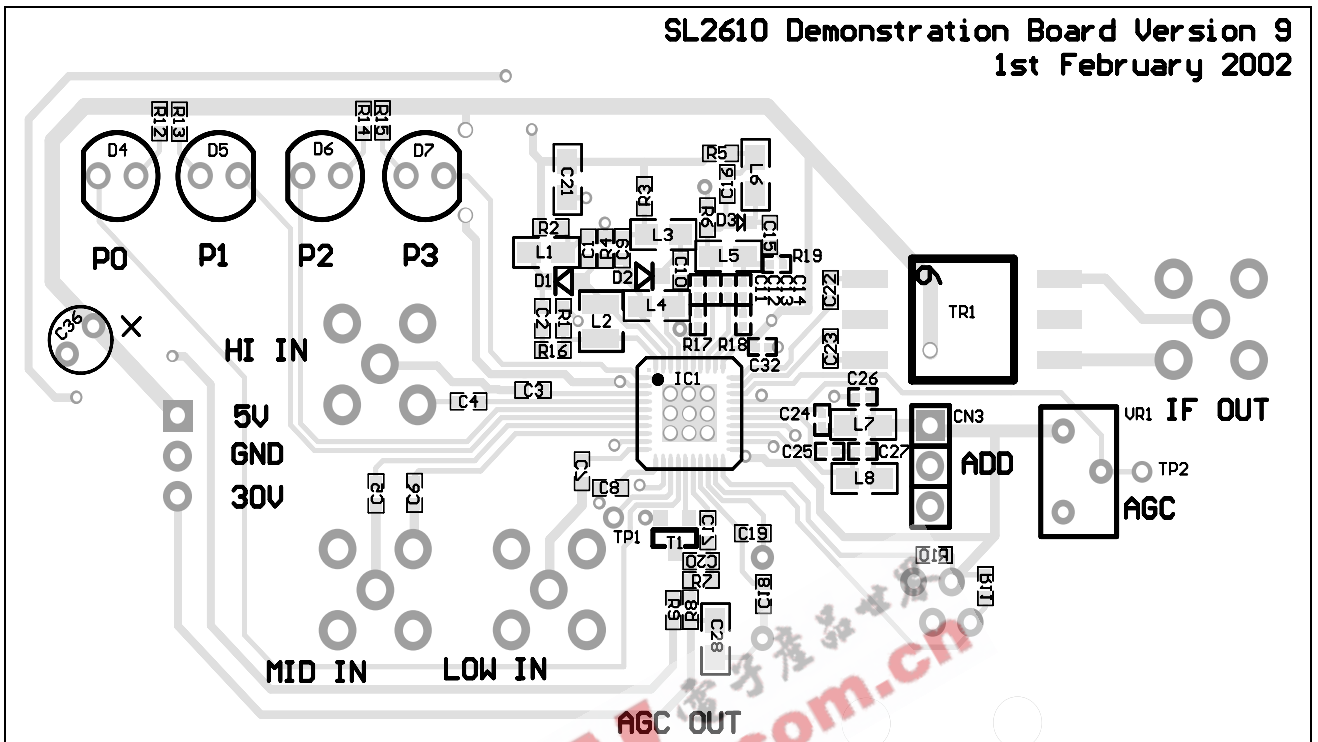

Figure 4 - SL2610 Evaluation Board Layout (Top)

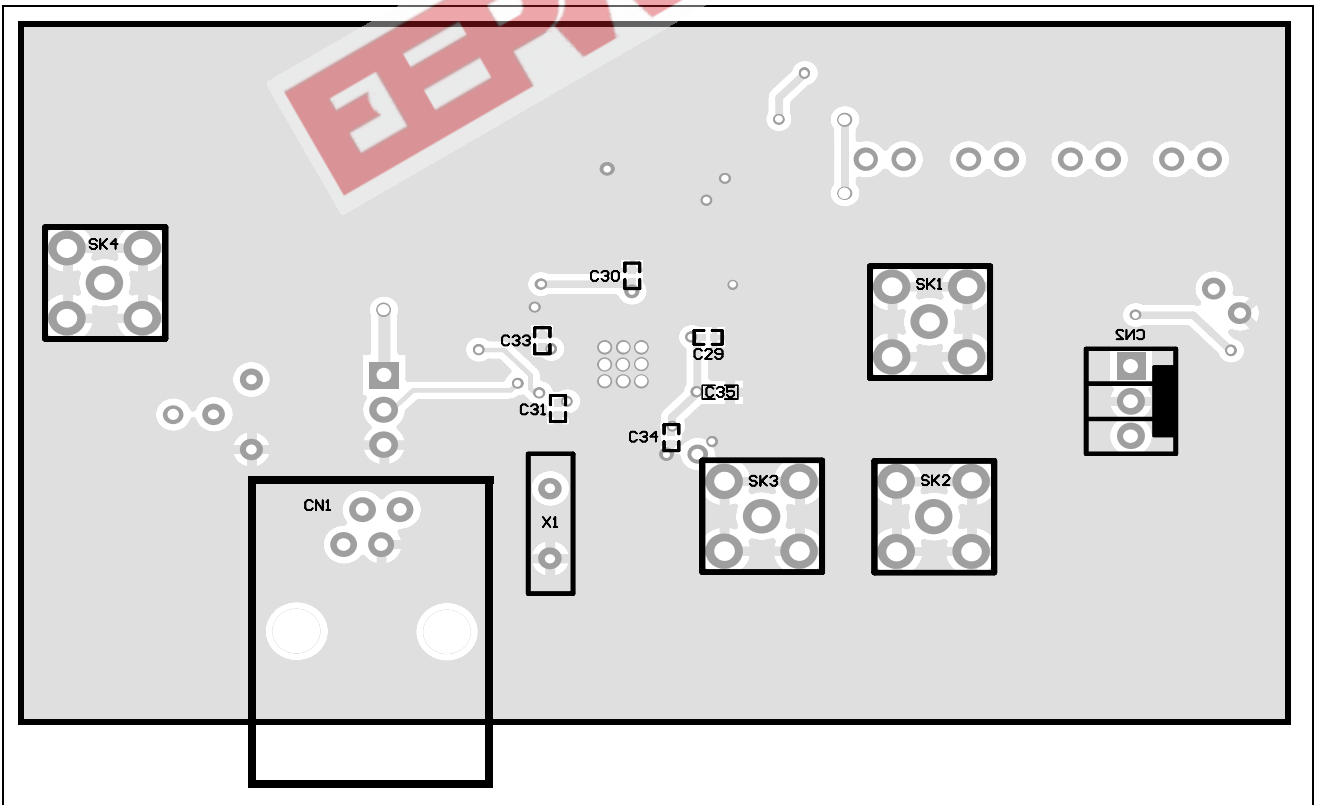

Figure 5 - SL2610 Evaluation Board Layout (Bottom)

1.0 Functional Description

The SL2610 is a multi band RF mixer oscillator with image reject and on-board frequency synthesizer. It is intended primarily for application in all band terrestrial tuners and requires a minimum external component count. It contains all elements required for RF downconversion to a standard IF with the exception of external VCO tank circuits.

The pin allocation is contained in Figure 2 and the block diagram in Figure 1.

1.1 Mixer/oscillator section

In normal application the RF input is interfaced to the selected mixer oscillator preamplifier through the tuner prefilter and AGC stages. The mixer input is arranged such that the signal can be coupled either differentially or single-ended, and achieves the specified minimum performance in both configurations. Band input impedances and NF are contained in Figure 11 and Figure 12 respectively. The converter two tone input spectra are contained in Figure 13 and Figure 14.

The preamplifier output then feeds the mixer stage where the required channel is image reject downconverted to the IF frequency. The local oscillator frequency for the downconversion is obtained from the on board local oscillator, which uses an external varactor tuned tank. Typical VCO applications are contained in Figures 8, 9 and 10.

The output of the mixer is then fed to the converter output driver which presents a matched $200\ \Omega$ differential load to an external IF shaping filter.

The output of the shaping filter is then coupled into the IFAMP stage, which provides further gain and offers a $50\ \Omega$ output impedance to interface direct with the tuner SAW filter.

The SL2610 contains a broadband level detect circuit whose output can be used to control the tuner AGC. The target level of the AGC detector is controlled by the voltage applied to the AGCBIAS pin. The characteristic of the target level is given in Figure 18.

1.2 PLL Frequency Synthesizer

The PLL frequency synthesizer section contains all the elements necessary, with the exception of a frequency reference and loop filter, to control a varicap tuned local oscillator, so forming a complete PLL frequency synthesised source. The device allows for operation with a high comparison frequency and is fabricated in high speed logic, which enables the generation of a loop with good phase noise performance. It can also be operated with comparison frequencies appropriate for frequency offsets as required in digital terrestrial (DTT) receivers.

The LO signal is multiplexed from the selected oscillator section to an internal preamplifier which provides gain and reverse isolation from the divider signals. The output of the preamplifier interfaces direct with the 15-bit fully programmable divider which is of MN+A architecture, where the dual modulus prescaler is 16/17, the A counter is 4-bits and the M counter is 11 bits.

The output of the programmable divider is fed to the phase comparator where it is compared in both phase and frequency domain with the comparison frequency. This frequency is derived either from the on-board crystal controlled oscillator or from an external reference source. In both cases the reference frequency is divided down to the comparison frequency by the reference divider which is programmable into 1 of 29 ratios as detailed in Table 1.

The output of the phase detector feeds a charge pump and loop amplifier section which when used with an external loop filter integrates the current pulses into the varactor line voltage.

The programmable divider output F_{pd} , divided by two and the reference divider output F_{comp} , can be switched to port P0 by programming the device into test mode. The test modes are described in Table 5.

2.0 Programming

The SL2610 is controlled by an I²C data bus and is compatible with both standard and fast mode formats.

Data and Clock are fed in on the SDA and SCL lines respectively as defined by I²C bus format. The synthesizer can either accept data (write mode) or send data (read mode). The LSB of the address byte (R/W) sets the device into write mode if it is low and read mode if it is high. Tables 2 and 3 illustrate the format of the data. The device can be programmed to respond to several addresses, which enables the use of more than one synthesizer in an I²C bus system (Tables 2 and 3). Table 4 shows how the address is selected by applying a voltage to the 'ADD' input. When the device receives a valid address byte, it pulls the SDA line low during the acknowledge period and during following acknowledge periods after further data bytes are received. When the device is programmed into read mode, the controller accepting the data must pull the SDA line low during all status byte acknowledge periods to read another status byte. If the controller fails to pull the SDA line low during this period the device generates an internal STOP condition which inhibits further reading.

2.1 Write mode

With reference to Table 2, bytes 2 and 3 contain frequency information bits 2¹⁴-2⁰ inclusive. Byte 4 controls the reference divider ratio bits R4-R0 (Table 1) and the charge pump setting bits C1-C0 (Table 6). Byte 5 controls the IF select (Table 8), the band select function bits BS1-BS0 (Table 7), the switching ports P3-P0 and the test modes (Table 5).

After reception and acknowledgement of a correct address (byte 1), the first bit of the following byte determines whether the byte is interpreted as a byte 2 or 4, a logic '0' indicating byte 2 and a logic '1' indicating byte 4. Having interpreted this byte as either byte 2 or 4 the following data byte will be interpreted as byte 3 or 5 respectively. Having received two complete data bytes, additional data bytes can be entered, where byte interpretation follows the same procedure, without re-addressing the device. This procedure continues until a STOP condition is received. The STOP condition can be generated after any data byte, if however it occurs during a byte transmission, the previous byte data is retained. To facilitate smooth fine tuning, the frequency data bytes are only accepted by the device after all 15 bits of frequency data have been received, or after the generation of a STOP condition.

2.2 Read mode

When the device is in read mode, the status byte read from the device takes the form shown Table 3.

Bit 1 (POR) is the power-on reset indicator, and this is set to a logic '1' if the Vcc supply to the device has dropped below 3V (at 25°C), e.g., when the device is initially turned ON. The POR is reset to '0' when the read sequence is terminated by a STOP command. When POR is set high this indicates that the programmed information may have been corrupted and the device reset to power up condition.

Bit 2 (FL) indicates whether the device is phase locked, a logic '1' is present if the device is locked and a logic '0' if the device is unlocked.

2.3 Programmable features

Synthesiser programmable divider	Function as described above.
Reference programmable divider	Function as described above.
Band selection	The required mixer oscillator band and RF input is selected by bits BS1-BS0, within data byte 5, as defined in Table 7.
IF selection	The centre of the image reject passband is selected by IF as defined in Table 8.
Charge pump current	The charge pump current can be programmed by bits C1-C0 within data byte 4, as defined in Table 6.
Ports P3-P0	These are configured as NPN open collector buffers and programmed by bits P3-P0. Logic '1' = on. Logic '0' = off (high impedance); default on power up. In test modes, when TE=1, ports P3-P0 respond according to T2-T0 respectively and previously transmitted data is lost.
Test mode	The test modes are invoked by setting bits T2-T0 as described in Table 5.

R4	R3	R2	R1	R0	Ratio
0	0	0	0	0	2
0	0	0	0	1	4
0	0	0	1	0	8
0	0	0	1	1	16
0	0	1	0	0	32
0	0	1	0	1	64
0	0	1	1	0	128
0	0	1	1	1	256
0	1	0	0	0	not allowed
0	1	0	0	1	5
0	1	0	1	0	10
0	1	0	1	1	20
0	1	1	0	0	40
0	1	1	0	1	80
0	1	1	1	0	160
0	1	1	1	1	320
1	0	0	0	0	not allowed
1	0	0	0	1	6
1	0	0	1	0	12
1	0	0	1	1	24
1	0	1	0	0	48
1	0	1	0	1	96
1	0	1	1	0	192
1	0	1	1	1	384
1	1	0	0	0	not allowed
1	1	0	0	1	7
1	1	0	1	0	14
1	1	0	1	1	28
1	1	1	0	0	56
1	1	1	0	1	112
1	1	1	1	0	224
1	1	1	1	1	448

Table 1 - Reference Division Ratio

	MSB					LSB				
Address	1	1	0	0	0	MA1	MA0	0	A	Byte 1
Programmable divider	0	2^{14}	2^{13}	2^{12}	2^{11}	2^{10}	2^9	2^8	A	Byte 2
Programmable divider	2^7	2^6	2^5	2^4	2^3	2^2	2^1	2^0	A	Byte 3
Control data	1	C1	C0	R4	R3	R2	R1	R0	A	Byte 4
Control data	IF	BS1	BS0	TE	P3/T2	P2/T1	P1/T0	P0	A	Byte 5

Table 2 - Write Data Format (MSB is transmitted first)

	MSB					LSB				
Address	1	1	0	0	0	MA1	MA0	1	A	Byte 1
Status Byte	POR	FL	0	0	0	0	0	0	A	Byte 2

Table 3 - Read Data Format (MSB is transmitted first)

A	:	Acknowledge bit
MA1,MA0	:	Variable address bits (see Table 4)
$2^{14}-2^0$:	Programmable division ratio control bits
R4-R0	:	Reference division ratio select (see Table 1)
C1,C0	:	Charge pump current select (see Table 6)
BS1-BS0	:	Band select bits (see Table 7)
IF	:	IF passband select (see Table 8)
TE	:	Test mode enable
T2-T0	:	Test mode control bits when TE=1 (see Table 5)
P3-P0	:	P3-P0 port output states
POR	:	Power on reset indicator
FL	:	Phase lock flag

MA1	MA0	Address Input Voltage Level
0	0	0-0.1V _{cc}
0	1	Open circuit
1	0	0.4V _{cc} – 0.6 V _{cc} #
1	1	0.9 V _{cc} - V _{cc}

Programmed by connecting a 30 k Ω resistor between pin and V_{cc}

Table 4 - Address Selection

TE	T2	T1	T0	Test Mode Description
0	X	X	X	Normal operation
1	0	0	0	Normal operation
1	0	0	1	Charge pump sink * Status byte FL set to logic '0'
1	0	1	0	Charge pump source * Status byte FL set to logic '0'
1	0	1	1	Charge pump disabled * Status byte FL set to logic '1'
1	1	0	0	Normal operation and Port P0 = Fpd/2
1	1	0	1	Charge pump sink * Status byte FL set to logic '0' Port P0 = Fcomp
1	1	1	0	Charge pump source * Status byte FL set to logic '0' Port P0 = Fcomp
1	1	1	1	Charge pump disabled * Status byte FL set to logic '1' Port P0 = Fcomp

Table 5 - Test Modes

* crystal and selected local oscillator need signals to enable charge pump test modes and to toggle status byte bit FL

X -'don't care'

C1	C0	Current in μA		
		Min.	Typ.	Max.
0	0	± 85	± 130	± 175
0	1	± 190	± 280	± 370
1	0	± 420	± 600	± 780
1	1	± 930	± 1300	± 1670

Table 6 - Charge pump current

BS1	BS0	Band Selected
0	0	LO Band
0	1	MID Band
1	0	HI band
1	1	HI band

Table 7 - Band select

IF input	Centre of Image Reject Passband	Passband Bandwidth
0	57 MHz	6 MHz
0	44 MHz	6 MHz
1	36 MHz	8 MHz

Table 8 - IF SELECT function

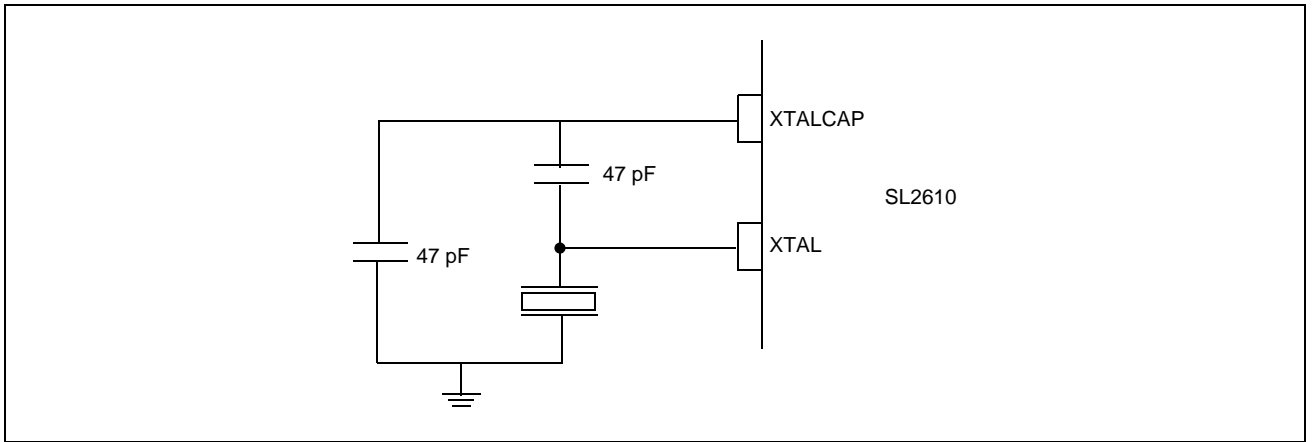

Figure 6 - Crystal Oscillator Application

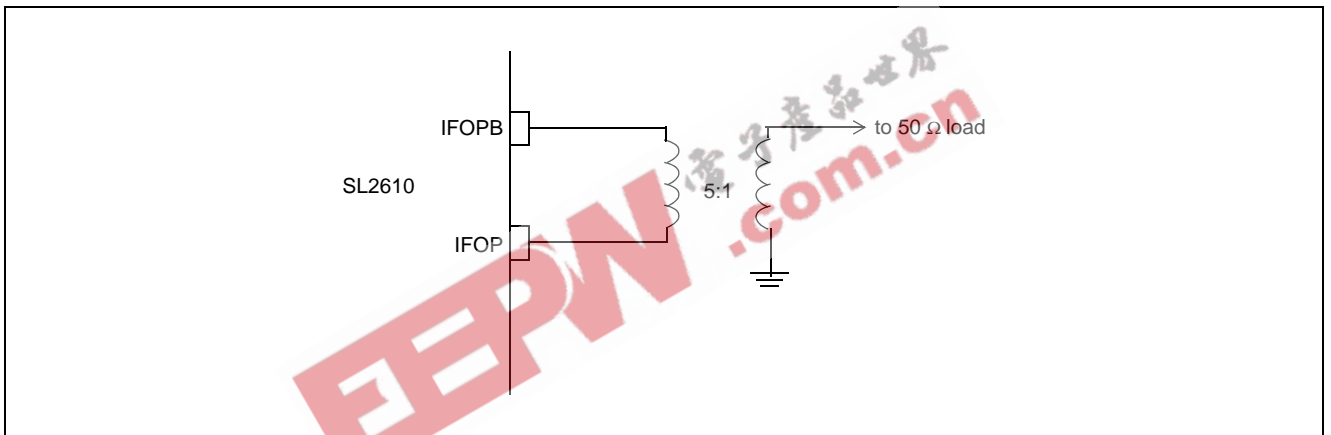

Figure 7 - Ifamp Output Load Condition for Test Purposes

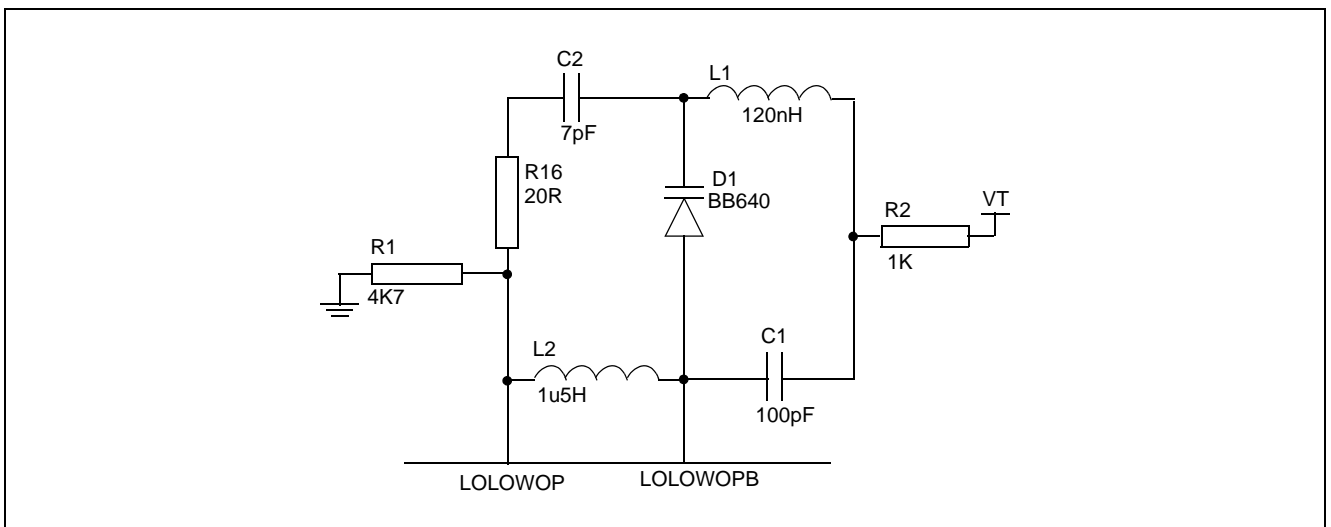

Figure 8 - LO Band VCO Application

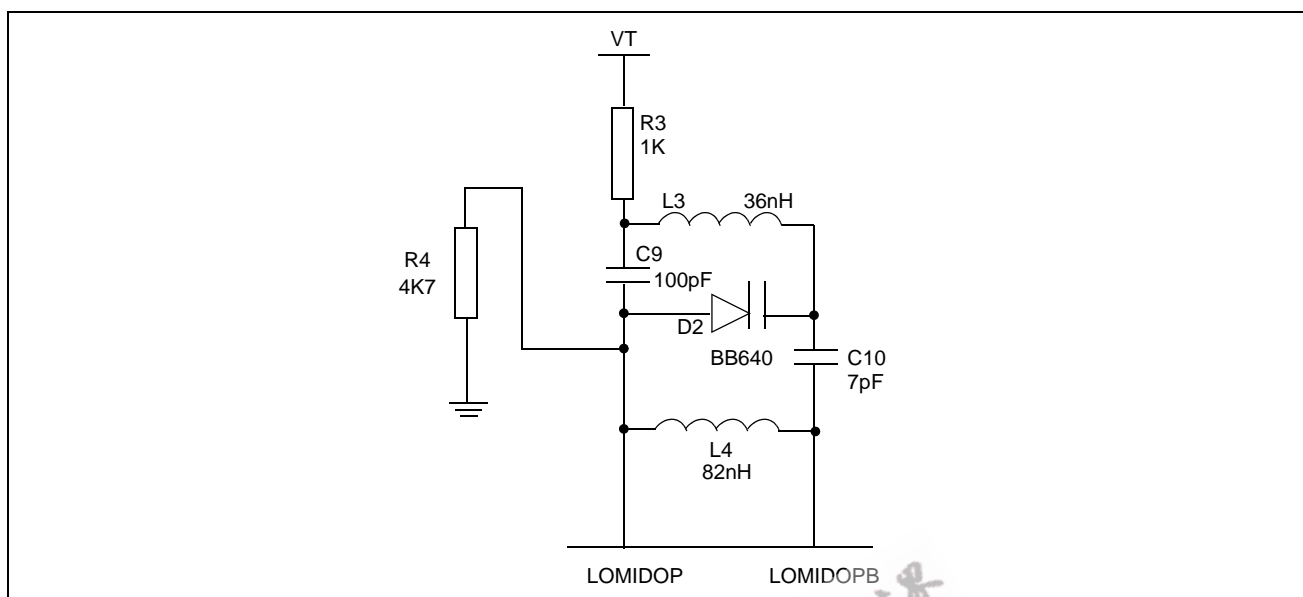

Figure 9 - Mid Band VCO Application

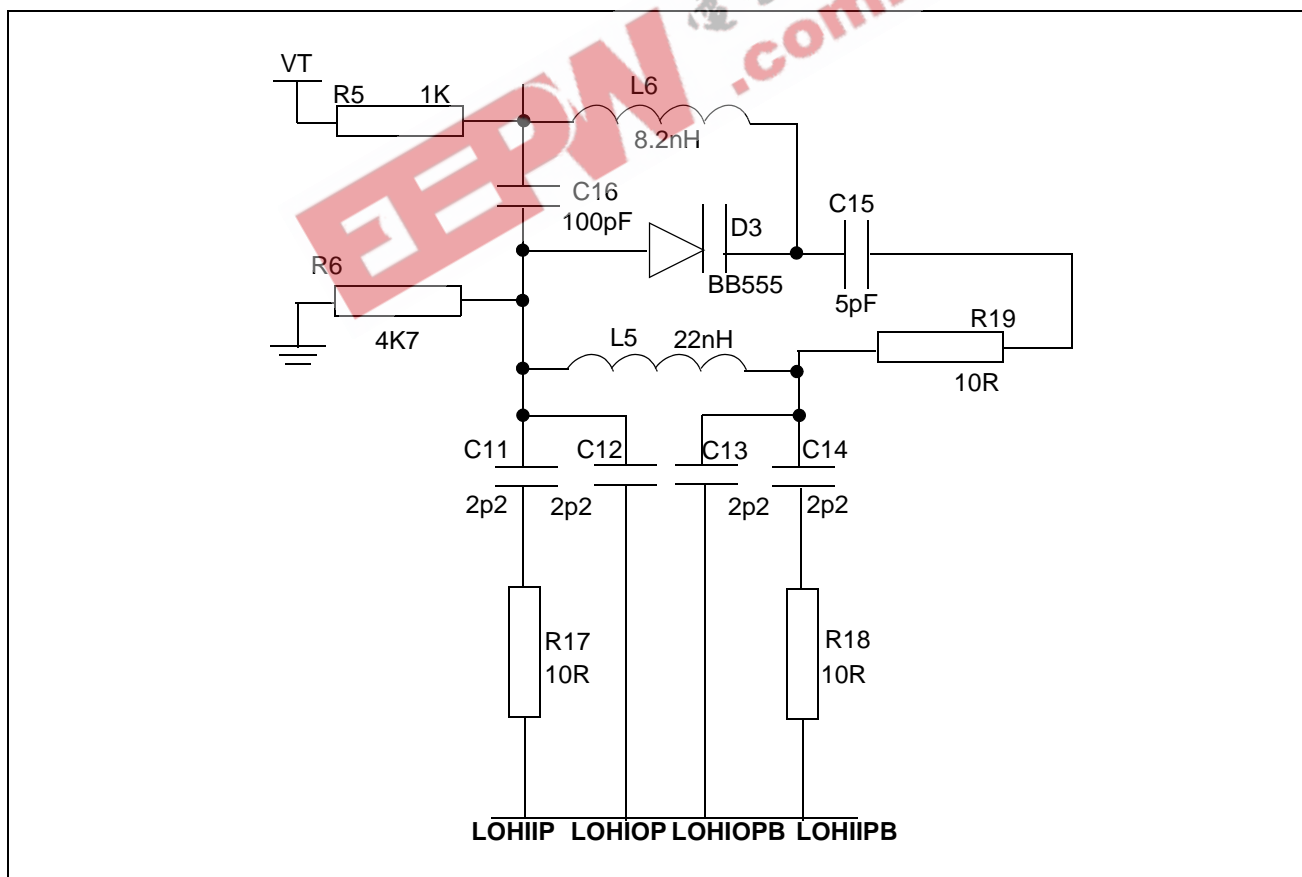

Figure 10 - HI Band VCO Application

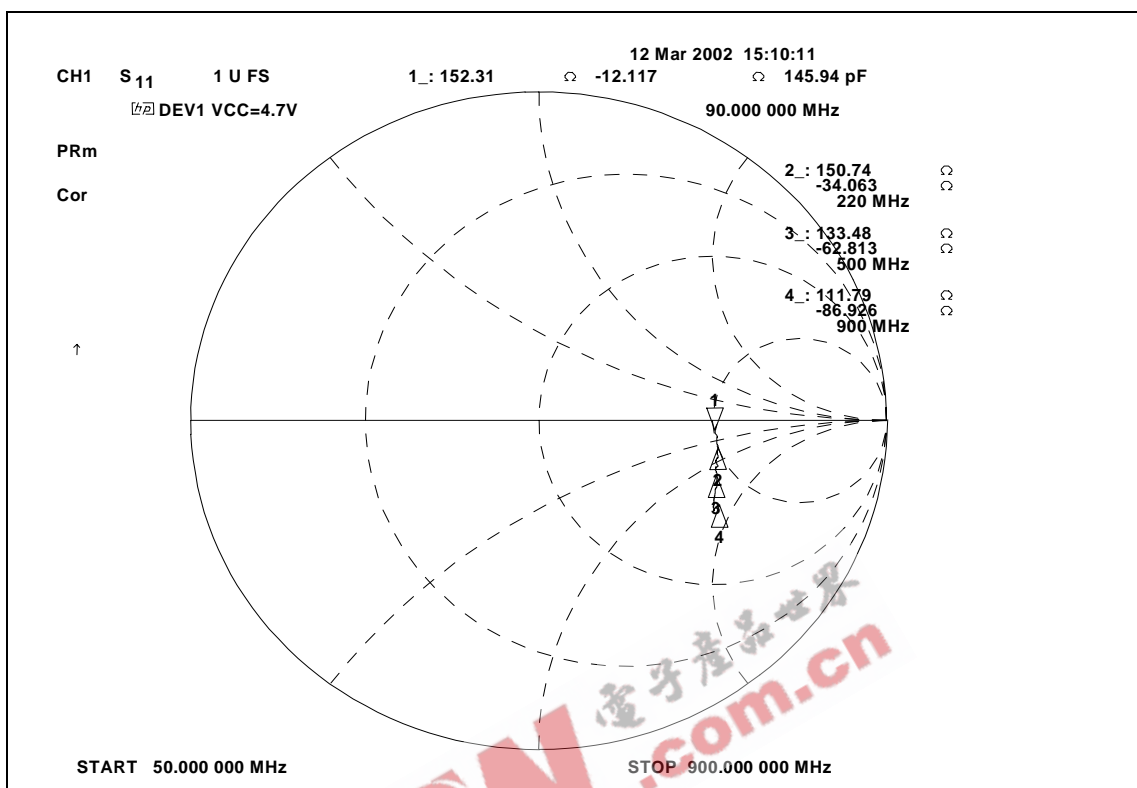

Figure 11 - LO, MID and HI Band Input Impedance

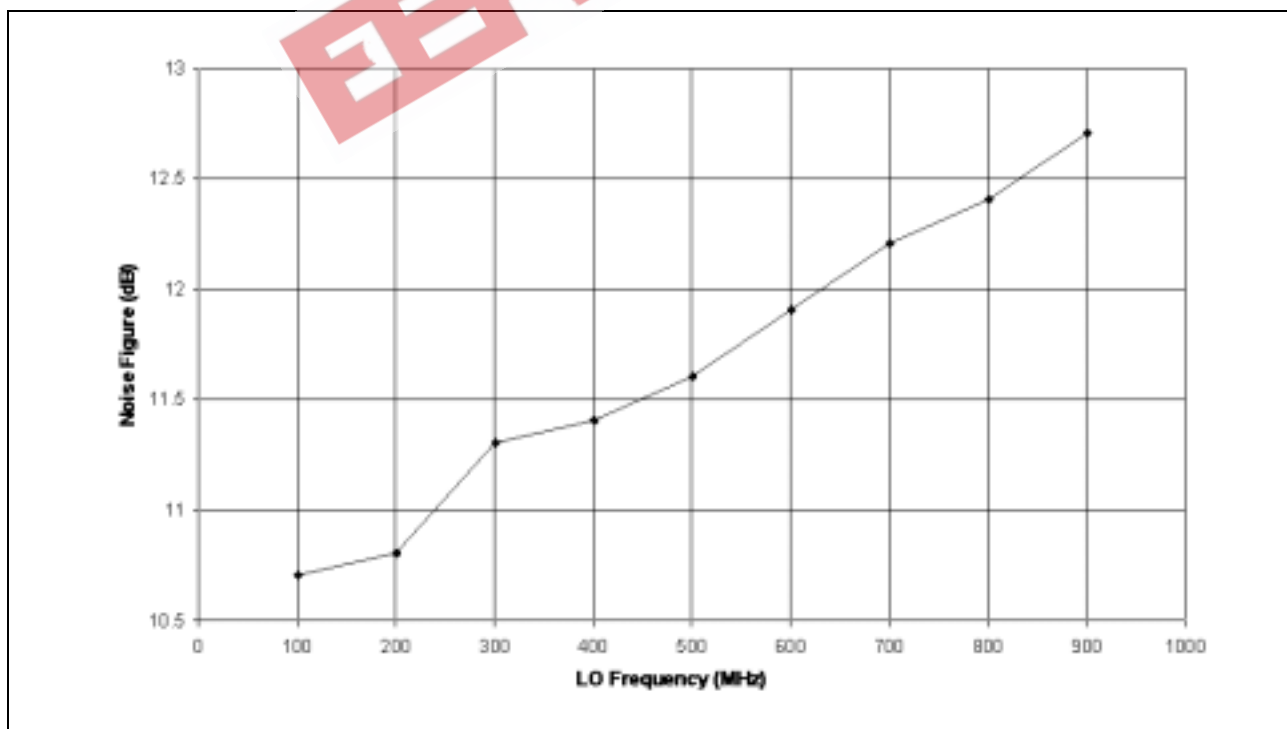

Figure 12 - Low, Mid and Hi Band Noise Figure versus Frequency

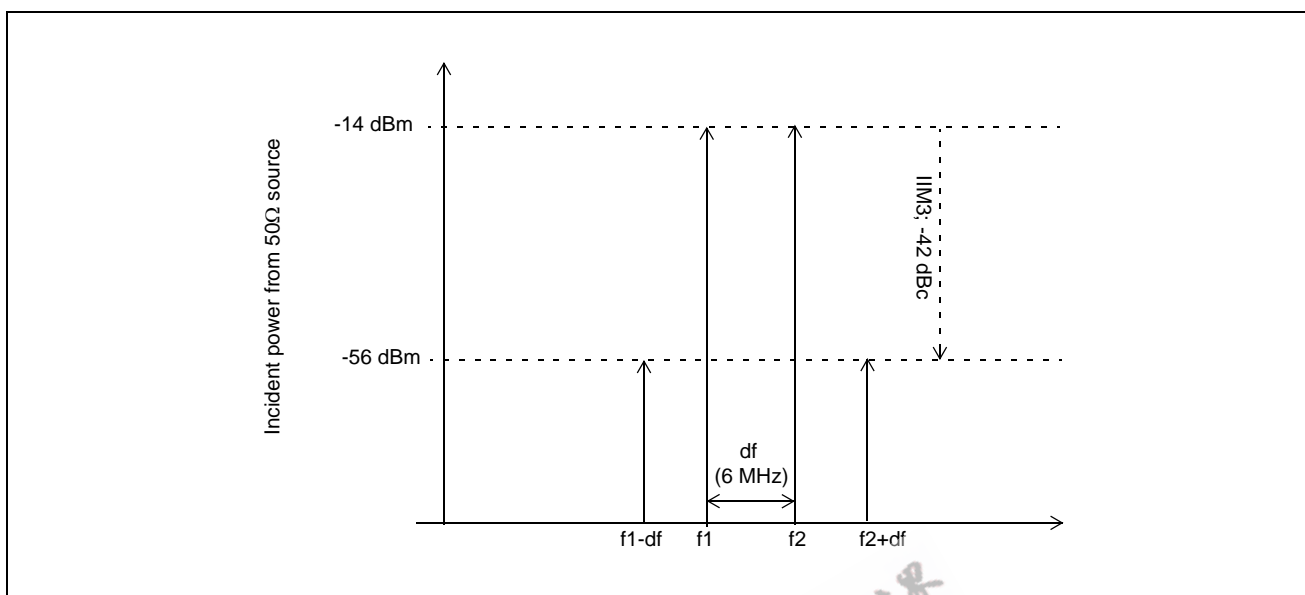

Figure 13 - Converter Third Order Two Tone Intermodulation Test Condition Spectrum, Input Referred, All Bands

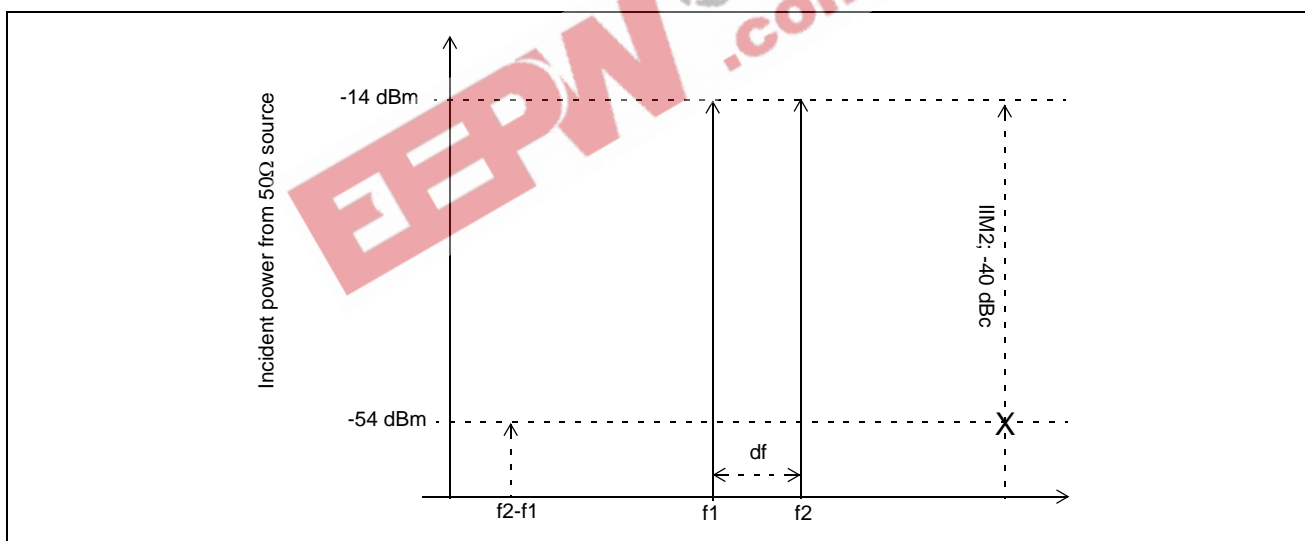

Figure 14 - Second Order Two Tone Intermodulation Test Condition Spectrum, Input Referred

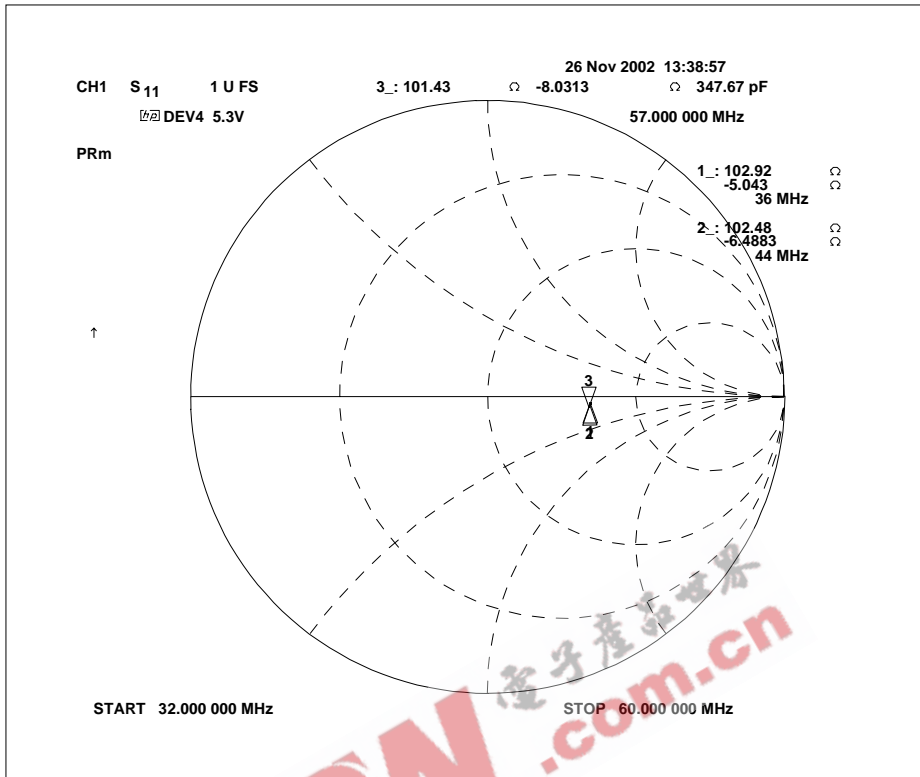

Figure 15 - Converter Output Impedance (Single Ended)

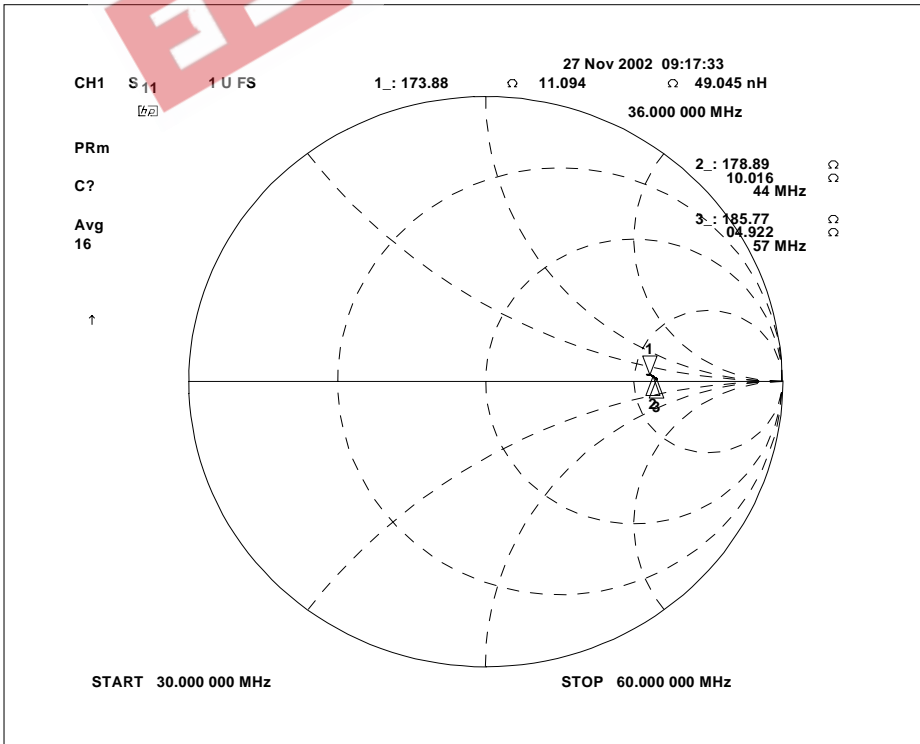

Figure 16 - IFAMP Input Impedance

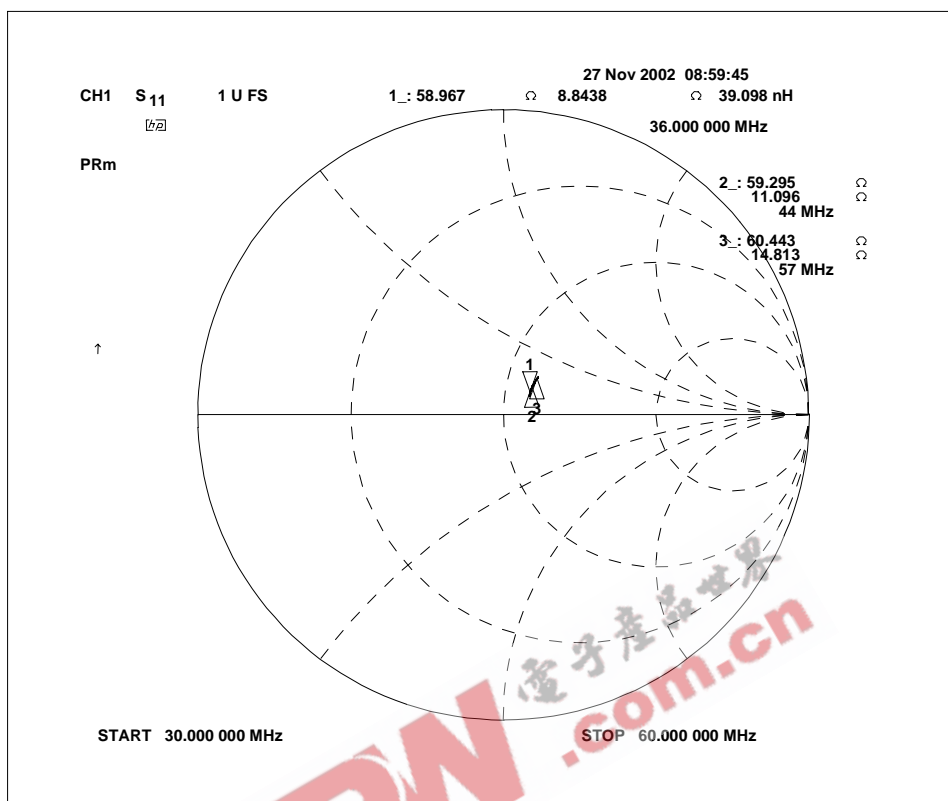

Figure 17 - IFAMP Output Impedance (Single Ended)

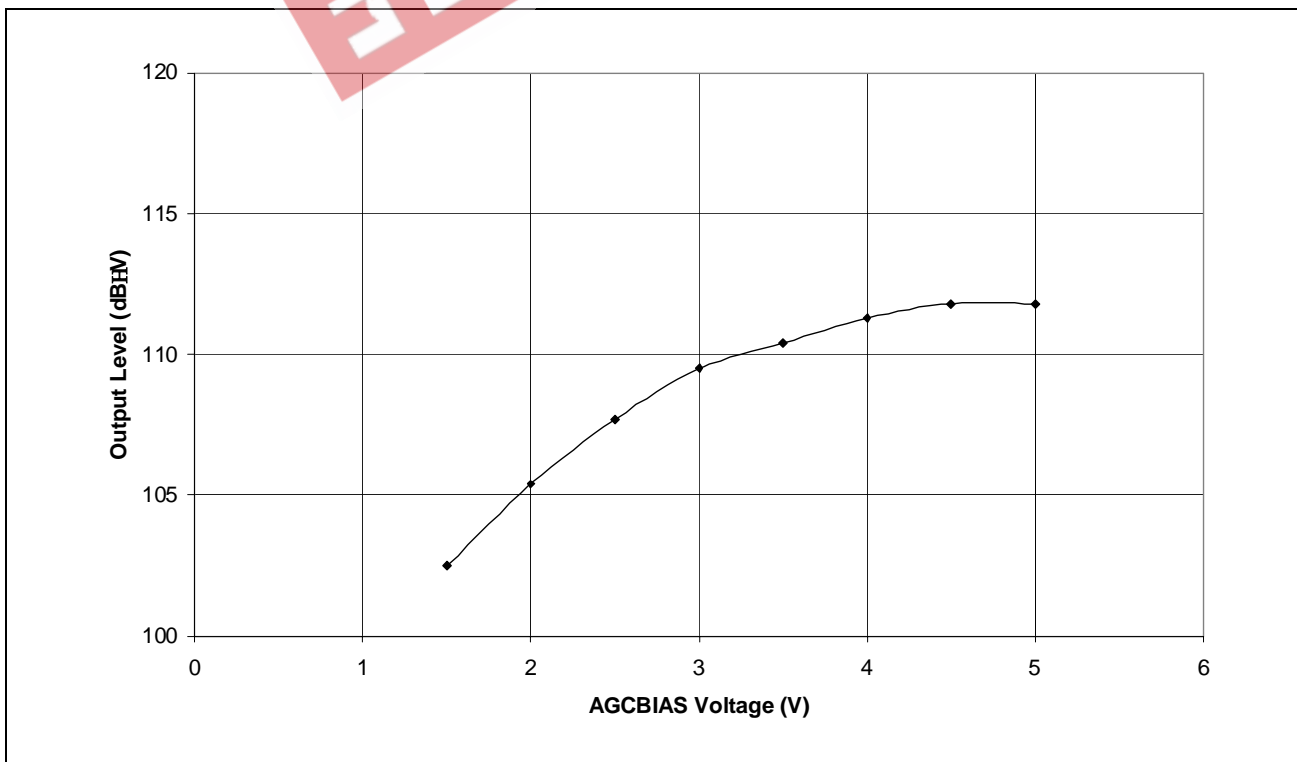

Figure 18 - Typical AGC Output Level Set versus AGCBIAS Voltage

Electrical Characteristics

Test conditions (unless otherwise stated)

$T_{amb} = -40^{\circ}\text{C}$ to 85°C , $V_{ee} = 0\text{ V}$, $V_{cc} = V_{cca} = V_{ccd} = 5\text{ V} \pm 5\%$

These characteristics are guaranteed by either production test or design. They apply within the specified ambient temperature and supply voltage unless otherwise stated.

Characteristic	Pin	Min.	Typ.	Max.	Units	Conditions
Supply current			163	196	mA	All switching ports off.
LO or MID BAND ENABLED						
Input frequency range		50		500	MHz	
Input impedance						See Figure 11 and refer to Note 8.
Input Noise Figure				13	dB	$T_{amb} = 27^{\circ}\text{C}$, see Figure 12, refer to Note 2, no correction for external filtering.
Converter gain		10 8.5		14 12.5	dB dB	At 36 MHz and 44 MHz IF frequency. At 57 MHz IF frequency. Conversion gain from 50 Ω single ended source to differential 200 Ω load, refer to Note 3.
Conversion gain to IFAMP output		28 25		36 33	dB dB	At 36 MHz and 44 MHz IF frequency. At 57 MHz IF frequency. Conversion gain from 50 Ω single ended source to 50 Ω single-ended load with output transformer as in Figure 7, see Notes 2 and 3.
Gain variation within channel			0.4	1	dB	Channel bandwidth 8 MHz within operating frequency range, see note (2), excluding interstage shaping filter ripple.
Converter input referred IP2		26			dBm	See Figure 14 and refer to Notes 4 and 6. Assuming ideal power match.
Converter input referred IM2				-40	dBc	See Figure 14 and refer to Notes 4 and 6.
Converter input referred IP3		7			dBm	See Figure 13 and refer to Notes 4 and 6. Assuming ideal power match.
Converter input referred IM3				-42	dBc	See Figure 13 and refer to Notes 4 and 6.
Input referred P1dB		101			dB μ V	
Local oscillator operation range		50		550	MHz	Refer to Note 7.
Local oscillator tuning range		68 200		225 465	MHz MHz	With application as in Figure 8. With application as in Figure 9.

Characteristic	Pin	Min.	Typ.	Max.	Units	Conditions
LO phase noise, SSB @ 1 kHz offset @ 10 kHz offset @ 100 kHz offset				-55 -86 -109	dBc/Hz dBc/Hz dBc/Hz	With application as in Figure 8 and Figure 9 outside of PLL loop bandwidth.
LO temperature stability				80	kHz/°C	Application as in Figure 8 and Figure 9. No temperature compensation.
LO turn on drift				100	kHz	Application as in Figure 8 and Figure 9, frequency drift over 15 minute period from turn on at a fixed ambient temperature. No temperature compensation.
LO to RF input leakage				60	dB μ V	Application as in Figures 8 and 9.
LO Vcc stability				0.5	MHz/V	
LO spurs due to RF pulling				-52	dBc	See Note 5.
HI BAND ENABLED						
Input frequency range		200		870	MHz	
Input impedance						See Figure 11 and refer to Note 8.
Input Noise Figure				13.5	dB	Tamb=27°C, see Figure 12, refer to Note 2, no correction for external filtering.
Converter gain		10 8.5		14 12.5	dB dB	At 36 MHz and 44 MHz IF frequency. At 57 MHz IF frequency. Conversion gain from 50 Ω single ended source to differential 200 Ω load, refer to Note 3.
Conversion gain to IFAMP output		28 25		36 33	dB dB	At 36 MHz and 44 MHz IF frequency. At 57 MHz IF frequency. Conversion gain from 50 Ω single ended source to 50 Ω single-ended load with output transformer as in Figure 7, see Notes 2 and 3.
Gain variation within channel			0.4	1	dB	Channel bandwidth 8 MHz within operating frequency range, see Note 3, excluding interstage shaping filter ripple.
Converter input referred IP2		26			dBm	See Figure 14 and refer to Notes 4 and 6. Assuming ideal power match.

Characteristic	Pin	Min.	Typ.	Max.	Units	Conditions
Converter input referred IM2				-40	dBc	See Figure 14 and refer to Notes 4 and 6.
Converter input referred IP3		7			dBm	See Figure 13 and refer to Notes 4 and 6. Assuming ideal power match.
Converter input referred IM3				-42	dBc	See Figure 13 and refer to Notes 4 and 6.
Input referred P1dB		101			dB μ V	
Local oscillator operation range		200		1000	MHz	Refer to Note 7.
Local oscillator tuning range		440		950	MHz	With application as in Figure 10.
LO phase noise, SSB @ 1 kHz offset @ 10 kHz offset @ 100 kHz offset				-55 -86 -109	dBc/Hz dBc/Hz dBc/Hz	With application as in Figure 10, outside of PLL loop bandwidth.
LO temperature stability				110	kHz/ $^{\circ}$ C	Application as in Figure 10. No temperature compensation.
LO turn on drift				100	kHz	Application as in Figure 10, frequency drift over 15 minute period from turn on at a fixed ambient temperature. No temperature compensation.
LO to RF input leakage				60	dB μ V	Application as in Figure 10.
LO Vcc stability				0.5	MHz/V	
LO spurs due to RF pulling				-52	dBc	See Note 5.
All Bands						
Converter output impedance			200		Ω	Differential, see Figure 15.
Image rejection		25 29 25	30 35 30		dB dB dB	At 36 MHz IF frequency, IF bit = 1. At 44 MHz IF frequency, IF bit = 0. At 57 MHz IF frequency, IF bit = 0. See Table 8. Tamb = 0 $^{\circ}$ C to +85 $^{\circ}$ C. Tank Schematics and layouts as in recommended application. See Figures 4 and 5.
Isolation between band inputs				-60	dBc	Level of desired signal converted to IF output through disabled band relative to signal converted through enabled band.
Composite output amplitude				3	dBm	

Characteristic	Pin	Min.	Typ.	Max.	Units	Conditions
IFAMP						
Input frequency range		32		60	MHz	
Input impedance			200		Ω	Differential, see Figure 16.
Gain		20 18.5		24 22.5	dB dB	At 36 MHz and 44 MHz IF frequency. At 57 MHz IF frequency. Voltage conversion gain from 200 Ω differential source to differential load as contained in Figure 7, see Note 3.
Output impedance			100		Ω	Differential, see Figure 17.
Output limiting		3 2.7			Vp-p Vp-p	At 36 MHz and 44 MHz IF frequency. At 57 MHz IF frequency. Differential into load as in Figure 7.
IFAMP OPIP3		135			dB μ V	Two output tones at 2 MHz separation at 104 dBuV into load as in Figure 7, see Note 2.
IFAMP OPIM3				-62	dBc	Two output tones at 2 MHz separation at 104 dBuV into load as in Figure 7, see Note 2.
AGCBIAS Leakage current	28	-100 -50		100 50	μ A μ A	Vee \leq Vagc1 \leq Vcc 1.5V \leq Vagc1 \leq 3.5V
AGCOUT voltage range	13	0.5		3	V	Max load current 20 μ A.
AGC output level set						See Figure 18.
Supply rejection				-52	dBc	Spurs introduced on converted output relative to desired signal by a supply ripple voltage of 10 mV p-p in the range 1 kHz to 100 kHz (including external supply decoupling).
Synthesiser						
SDA, SCL	19, 20					
Input high voltage		3		5.5	V	Input voltage = Vee to Vcc Input voltage = Vee to 5.5 V, Vcc=Vee
Input low voltage		0		1.5	V	
Input current		-10		10	μ A	
Leakage current				10	μ A	
Hysteresis	19, 20		0.4		V	
SDA output voltage	19			0.4 0.6	V V	Isink = 3 mA Isink = 6 mA
SCL clock rate	20			400	kHz	

Characteristic	Pin	Min.	Typ.	Max.	Units	Conditions
Charge pump output current	16					See Table 6. V _{pin16} = 2 V
Charge pump output leakage	16		±3	±10	nA	V _{pin16} = 2 V
Charge pump drive output current	15	0.5			mA	V _{pin15} = 0.7 V
Crystal frequency	17, 18	4		16	MHz	Application as in Figure 6.
Recommended crystal series resonance		10		200	Ω	4 MHz parallel resonant crystal.
External reference input frequency	17, 18	4		20	MHz	Sinewave coupled through 10 nF blocking capacitor.
External reference drive level	18	0.2		0.5	V _{pp}	Sinewave coupled through 10 nF blocking capacitor.
Phase detector comparison frequency		.03125		0.25	MHz	
Equivalent phase noise at phase detector			-158			With 4 MHz crystal, SSB, within loop bandwidth. With F _{comp} = 125 kHz
RF division ratio		240		32767		
Reference division ratio						See Table 1.
Switching ports P0-P3 sink current leakage current	1, 5, 6, 14	10		10	mA μA	V _{port} = 0.7 V V _{port} = V _{cc}
Address select Input high current	24			1	mA	See Table 4. V _{in} =V _{cc}
Address select Input low current	24			-0.5	mA	V _{in} =V _{ee}

Notes

- All power levels are referred to 50 Ω, and 0 dBm = 107 dBμV.
- Total system with final load as in Figure 7, including an interstage IF shaping filter with IL of 2 dB and characteristic impedance of 200 Ω differential.
- The specified gain is determined by the following formula;
 $G_s = G_m + V_{tr}$ where G_s = gain as specified
 G_m = gain as measured with specified load conditions
 V_{tr} = voltage transformation ratio of transformer as in Figure 7
- Two input tones within RF operating range at -14 dBm from 50 Ω single ended source with 200 Ω differential output load. DC output current must be shunted to V_{cc} through suitable inductor, i.e. 10 μH.
- Modulation spurs introduced on local oscillator through injection locking of the local oscillator by an undesired RF carrier.
Desired carrier at 80 dBμV, undesired carrier at 90 dBμV at an offset frequency of f_d plus $42+f_c$ MHz, where f_d is desired carrier frequency, f_c is US chrominance sub carrier and 42 equals 7 channel spacings.
- All intermodulation specifications are measured with a single-ended input.
- Operation range is defined as the region over which the oscillator presents a negative impedance.
- Target to achieve 6 dB minimum S11.

Absolute Maximum Ratings

All voltages are referred to Vee at 0 V.

Characteristic	Min.	Max.	Units	Conditions
Supply voltage	-0.3	6	V	
RF input voltage		117	dB μ V	Transient condition only.
All I/O port DC offsets	-0.3	V _{cc} +0.3	V	
Total port current		20	mA	
Storage temperature	-55	150	°C	
Junction temperature		125	°C	Power applied.
Package thermal resistance, chip to ambient		27	°C/W	Package paddle soldered to ground.
Power consumption at 5.25V		1	W	
ESD protection	1		kV	Mil-std 883B method 3015 cat1

EEPW.com.cn 电子世界

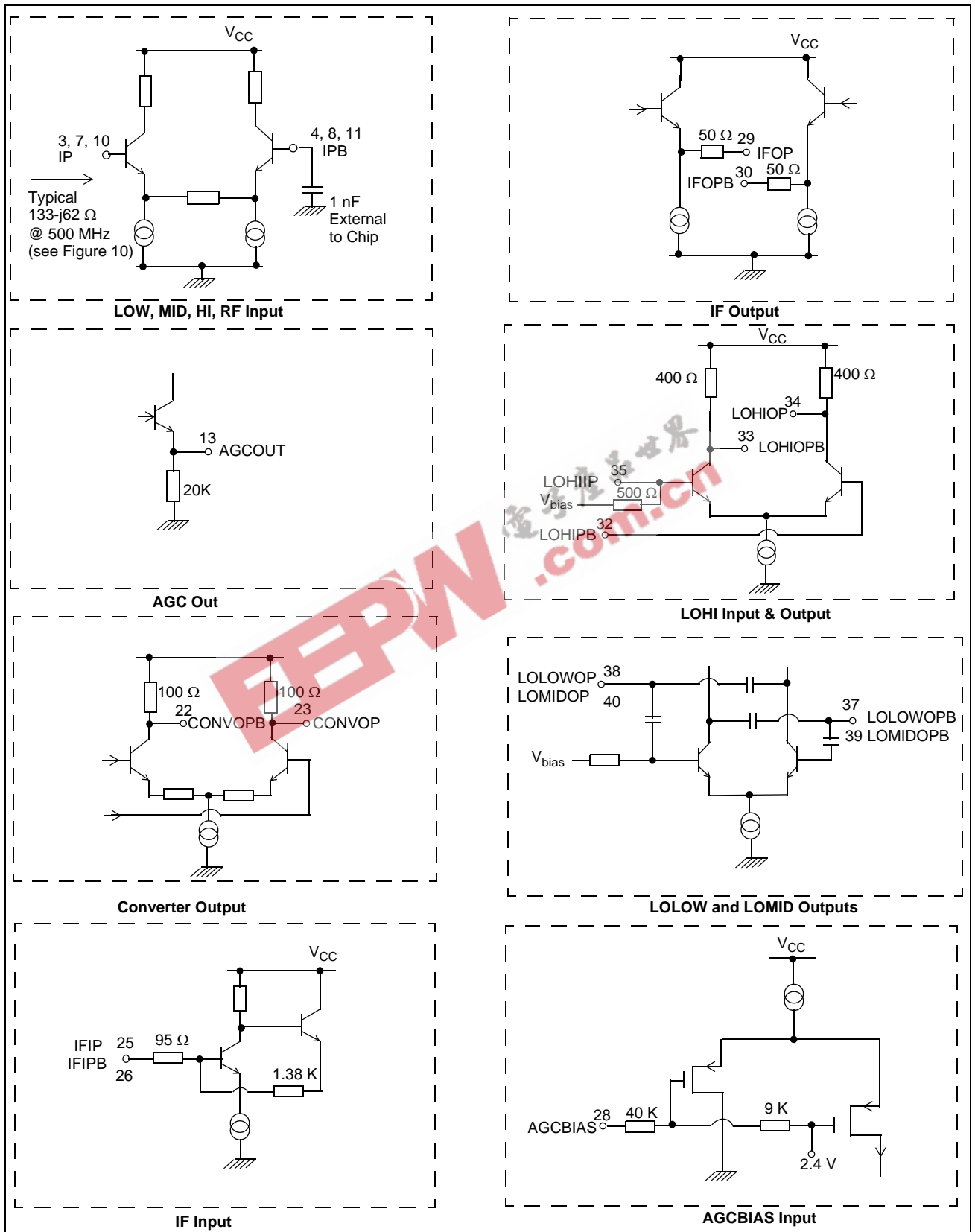

Figure 19 - Input and Output Interface Circuits (RF Section)

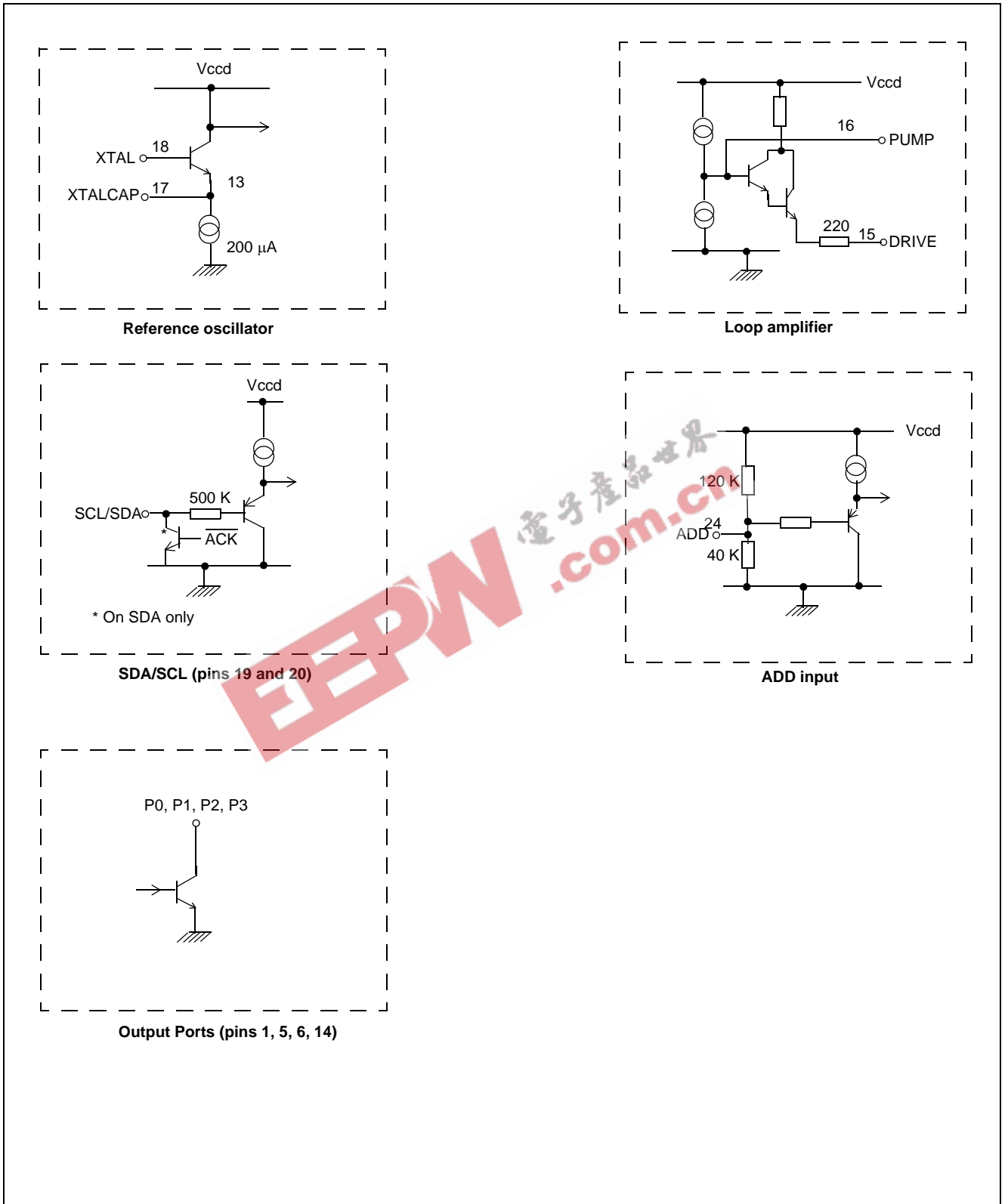
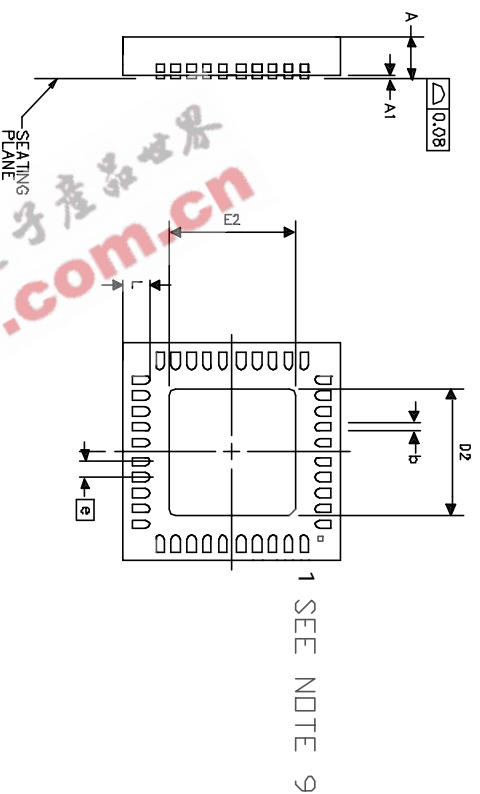
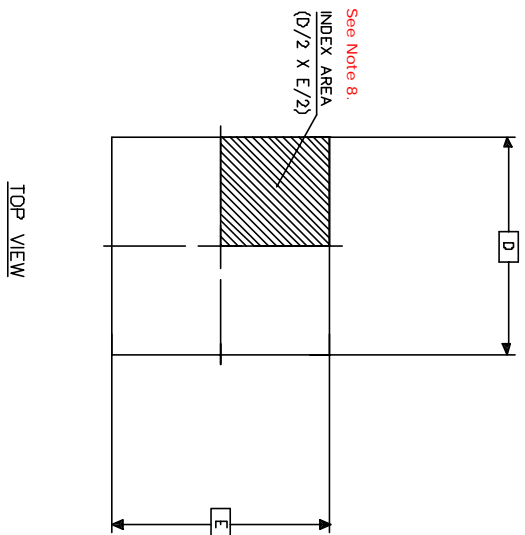

Figure 20 - Input and Output Interface Circuits (PLL Section)



SYMBOL	COMMON DIMENSIONS	
	MIN.	MAX.
$^5 M$	0.80	1.00
$^5 B$	0.00	0.05
$^5 L$	0.18	0.30
A	6.00	BSC
A1	4.10	4.30
b	6.00	BSC
D	4.10	4.30
D2	6.00	BSC
E	4.10	4.30
E2	4.10	4.30
N	40	
Nd	10	
Ne	10	
Ne	0.50	BSC
L	0.30	0.50

DRAWING CONFORMS TO
JEDEC MD-220

- NOTES:
1. DIMENSIONING & TOLERANCES CONFORM TO ASME Y14.5M. - 1994.
 2. N IS THE NUMBER OF TERMINALS.
 3. DIMENSION b APPLIES TO PLATED TERMINAL AND IS MEASURED BETWEEN 0.25 AND 0.30mm FROM TERMINAL.
 4. ALL DIMENSIONS ARE IN MILLIMETERS.
 5. LEAD COUNT IS 40.
 6. PACKAGE WARPAGE MAX 0.08mm.
 7. NOT TO SCALE.
 8. TERMINAL #1 IDENTIFIER MUST BE LOCATED WITHIN THE ZONE INDICATED AND MAY BE EITHER A MOULD OR MARKED FEATURE.
 9. PIN 1 ID CAN BE A COMBINATION OF DOT AND/OR CHAMFER

© Zarlink Semiconductor 2004 All rights reserved.

ISSUE	1	2	3
ACN	211246	212948	CDCA
DATE	11Jul01	18Jun02	17Dec04
APPRD.			



Previous package codes

LH

Package Code

LC

Package Outline for 40 Lead
QFN Pull back lead
(6 x 6 x 0.9 mm)

109045



**For more information about all Zarlink products
visit our Web Site at**

www.zarlink.com

Information relating to products and services furnished herein by Zarlink Semiconductor Inc. or its subsidiaries (collectively "Zarlink") is believed to be reliable. However, Zarlink assumes no liability for errors that may appear in this publication, or for liability otherwise arising from the application or use of any such information, product or service or for any infringement of patents or other intellectual property rights owned by third parties which may result from such application or use. Neither the supply of such information or purchase of product or service conveys any license, either express or implied, under patents or other intellectual property rights owned by Zarlink or licensed from third parties by Zarlink, whatsoever. Purchasers of products are also hereby notified that the use of product in certain ways or in combination with Zarlink, or non-Zarlink furnished goods or services may infringe patents or other intellectual property rights owned by Zarlink.

This publication is issued to provide information only and (unless agreed by Zarlink in writing) may not be used, applied or reproduced for any purpose nor form part of any order or contract nor to be regarded as a representation relating to the products or services concerned. The products, their specifications, services and other information appearing in this publication are subject to change by Zarlink without notice. No warranty or guarantee express or implied is made regarding the capability, performance or suitability of any product or service. Information concerning possible methods of use is provided as a guide only and does not constitute any guarantee that such methods of use will be satisfactory in a specific piece of equipment. It is the user's responsibility to fully determine the performance and suitability of any equipment using such information and to ensure that any publication or data used is up to date and has not been superseded. Manufacturing does not necessarily include testing of all functions or parameters. These products are not suitable for use in any medical products whose failure to perform may result in significant injury or death to the user. All products and materials are sold and services provided subject to Zarlink's conditions of sale which are available on request.

Purchase of Zarlink's I²C components conveys a licence under the Philips I²C Patent rights to use these components in and I²C System, provided that the system conforms to the I²C Standard Specification as defined by Philips.

Zarlink, ZL and the Zarlink Semiconductor logo are trademarks of Zarlink Semiconductor Inc.

Copyright Zarlink Semiconductor Inc. All Rights Reserved.

TECHNICAL DOCUMENTATION - NOT FOR RESALE
