

SWITCHING REGULATOR POWER OUTPUT STAGES

DESCRIPTION

The SM645/646/647 series of Power Output Stages are especially designed to be driven with standard PWM integrated circuits to form an efficient switching power supply. The SM645, SM646 and SM647 are optimized for non-isolated Buck and Buck-Boost application. The hybrid circuit construction utilizes thick film resistors on a beryllia substrate for maximum thermal conductivity and resultant low thermal impedance. All of the active elements in the hybrid are fully passivated.

FEATURES

- Equivalent to the Unitorde PIC 645, 646, 647
- 15A current capability
- Cost saving design reduces size, improves efficiency, reduces noise and RFI
- High operating frequency (to > 100KHz) results in smaller inductor-capacitor filter and improved power supply response time
- High operating efficiency at 7A typical performance -
Rise and fall time < 300ns
Efficiency > 85%

HIGH RELIABILITY FEATURES

- ◆ Available with high reliability processing

FUNCTIONAL DIAGRAM

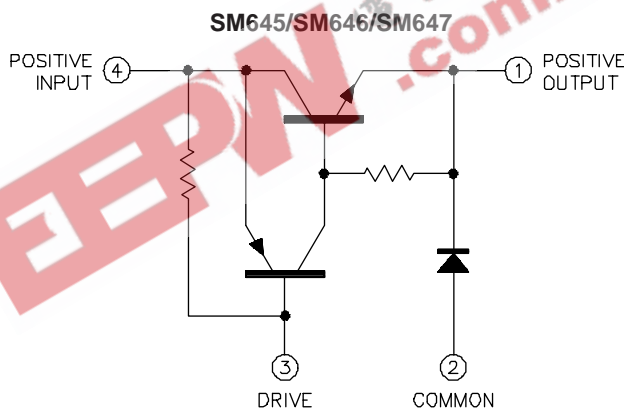

SM645/SM646/SM647

ABSOLUTE MAXIMUM RATINGS (Note 1)

	SM645	SM646	SM647
Input Voltage, V_{4-2}	60V	80V	100V
Output Voltage, V_{1-2}	60v	80v	100V
Drive Input Reverse Voltage, V_{3-4}	5V	5V	5V
Continuous Output Current, I_1	15A	15A	15A
Peak Output Current	20A	20A	20A
Drive Current, I_3	-0.4A	-0.4A	-0.4A

Thermal Resistance

Power Switch, θ_{j-c}	2.0°C/W
Commutating Diode	2.0°C/W
Case to Ambient, θ_{c-a}	30.0°C/W

Operating Junction Temperature

Hermetic (K Package)	150°C
Storage Temperature Range	-65°C to 150°C
Lead Temperature (Soldering, 10 Seconds)	300°C

Note 1. Exceeding these ratings could cause damage to the device.

THERMAL DATA

K Package:

Thermal Resistance-Junction to Case, θ_{j-c}	2.0°C/W
Thermal Resistance-Junction to Ambient, θ_{j-a}	35°C/W

Note A. Junction Temperature Calculation: $T_j = T_A + (P_D \times \theta_{j-a})$.

Note B. The above numbers for θ_{j-c} are maximums for the limiting thermal resistance of the package in a standard mounting configuration. The θ_{j-a} numbers are meant to be guidelines for the thermal performance of the device/pc-board system. All of the above assume no ambient airflow.

RECOMMENDED OPERATING CONDITIONS (Note 2)

	SM645	SM646	SM647
Input Voltage, V_{4-2}	50V	70V	90V
Output Voltage, V_{1-2}	50v	70v	90V
Drive Input Reverse Voltage, V_{3-4}	4V	4V	4V
Output Current, I_1	13A	13A	13A
Drive Current, I_3	-0.3A	-0.3A	-0.3A

Operating Ambient Temperature Range

SM6XXK	0°C to 70°C
SM6XXHRK	-55°C to 125°C

Note 2. Range over which the device is functional.

ELECTRICAL CHARACTERISTICS

(Unless otherwise specified, these specifications apply for the operating ambient temperature of $T_A = 25^\circ\text{C}$. Low duty cycle pulse testing techniques are used which maintains junction and case temperatures equal to the ambient temperature.)

Parameter	Test Conditions	SG645/646/647			Units
		Min.	Typ.	Max.	
On-State Voltage (Note 3)	$I_4 = 7A(-7A), I_3 = -30mA(30mA)$		1.0	1.5	V
	$I_4 = 15A(-15A), I_3 = -30mA(30mA)$		2.5	3.5	V
Diode Forward Voltage (Note 3)	$I_4 = 7A(-7A)$		0.85	1.25	V
	$I_4 = 15A(-15A)$		0.95	1.75	V
Off-State Current	$V_4 = \text{Rated input voltage}$		0.1	10	μA
	$V_4 = \text{Rated input voltage}, T_A = 125^\circ\text{C}$		10		μA
Diode Reverse Current	$V_1 = \text{Rated output voltage}$		1.0	10	μA
	$V_1 = \text{Rated output voltage}, T_A = 125^\circ\text{C}$		500		μA

Note 3. Pulse test: Duration = 300 μs , Duty Cycle $\leq 2\%$.

ELECTRICAL CHARACTERISTICS (continued)

Parameter	Test Conditions	SG645/646/647			Units
		Min.	Typ.	Max.	
Dynamic Characteristics (See Figures 1 & 2) (Notes 4 & 5)					
Current Delay Time			35	60	ns
Current Rise Time			65	150	ns
Voltage Rise Time			40	60	ns
Voltage Storage Time			700		ns
Voltage Fall Time			70	175	ns
Current Fall Time			175	300	ns
Efficiency (Note 5)			85		%

AC TEST CIRCUIT AND SWITCHING TIME WAVEFORMS (Note 6)

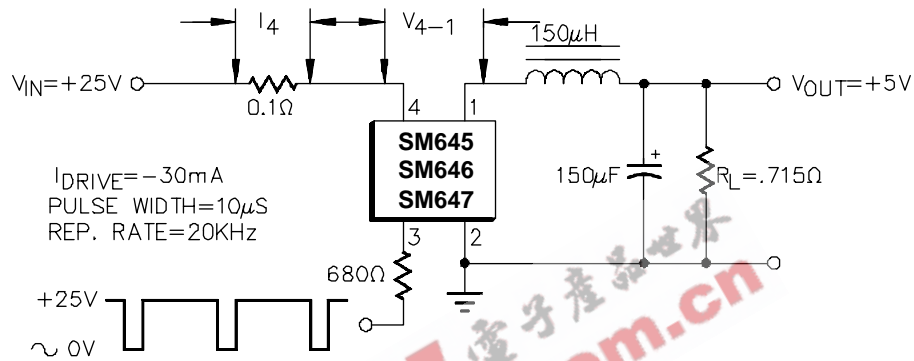

FIGURE 1 - SM645/646/647 SWITCHING SPEED CIRCUIT

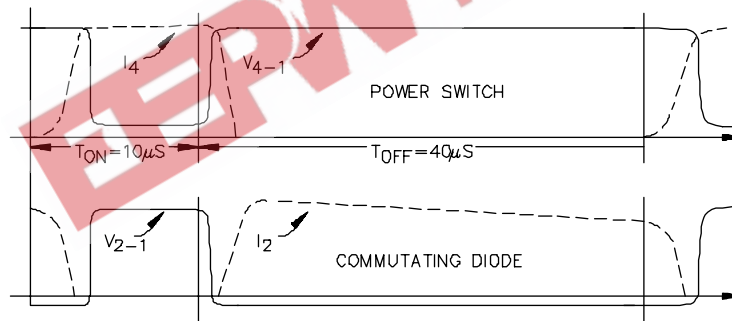

FIGURE 2 - SM645/646/647 SWITCHING WAVEFORMS

Note 4. In switching an inductive load, the current will lead the voltage on turn-on and lag the voltage on turn-off (see Figure 2). Therefore, Voltage Delay Time ($t_{DV} \cong t_{di} + t_{ri}$) and Current Storage Time ($t_{SI} \cong t_{sv} + t_{iv}$).

Note 5. The efficiency is a measure of internal power losses and is equal to Output Power divided by Input Power. The switching speed circuit of Figure 1, in which the efficiency measured, is representative of typical operating conditions for the SM600 series switching regulators.

APPLICATION CIRCUITS

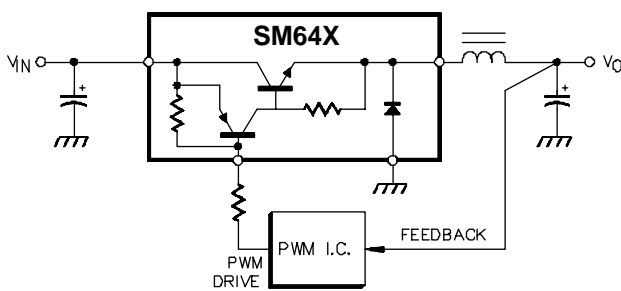

FIGURE 3 - STEP DOWN (BUCK) CONVERTER

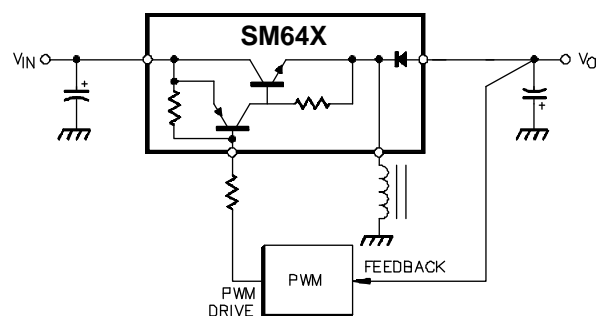

FIGURE 4 - NEGATIVE OUTPUT DOWN/UP (BUCK-BOOST) CONVERTER

SM645/SM646/SM647

CONNECTION DIAGRAMS & ORDERING INFORMATION (See Note Below)

Package	Part No.	Ambient Temperature Range	Connection Diagram
4-TERMINAL TO-3 METAL CAN K - PACKAGE	SM645K	0°C to 70°C	
	SM645HRK	-55°C to 125°C	
	SM646K	0°C to 70°C	
	SM646HRK	-55°C to 125°C	
	SM647K	0°C to 70°C	
	SM647HRK	-55°C to 125°C	

EEPW 电子产品世界 .com.cn

Note 1. All packages are viewed from the top.
2. Consult factory for additional screening available.