

## SWITCHING REGULATOR POWER OUTPUT STAGES

### DESCRIPTION

The SM600/601/602 and SM610/611/612 series of Power Output Stages are especially designed to be driven with standard PWM integrated circuits to form an efficient switching power supply. The SM600, SM601 and SM602 are optimized for non-isolated Buck and Buck-Boost application, where SM610, SM611 and SM612 are best suited for DC-DC Boost type applications as well as negative output Buck Converters. The hybrid circuit construction utilizes thick film resistors on a beryllia substrate for maximum thermal conductivity and resultant low thermal impedance. All of the active elements in the hybrid are fully passivated.

### FEATURES

- Equivalent to the Unitrode PIC 600, 601, 602, 610, 611, 612
- 5A current capability
- Designed and characterized for switching regulator applications such as Buck, Boost, and Buck-Boost type
- Cost saving design reduces size, improves efficiency, reduces noise and RFI
- High operating efficiency at 2A typical performance - Rise and fall time < 75ns Efficiency > 85%
- Electrically isolated, 4-pin, TO-66 hermetic case

### HIGH RELIABILITY FEATURES

- ◆ Available with high reliability processing

### FUNCTIONAL DIAGRAM

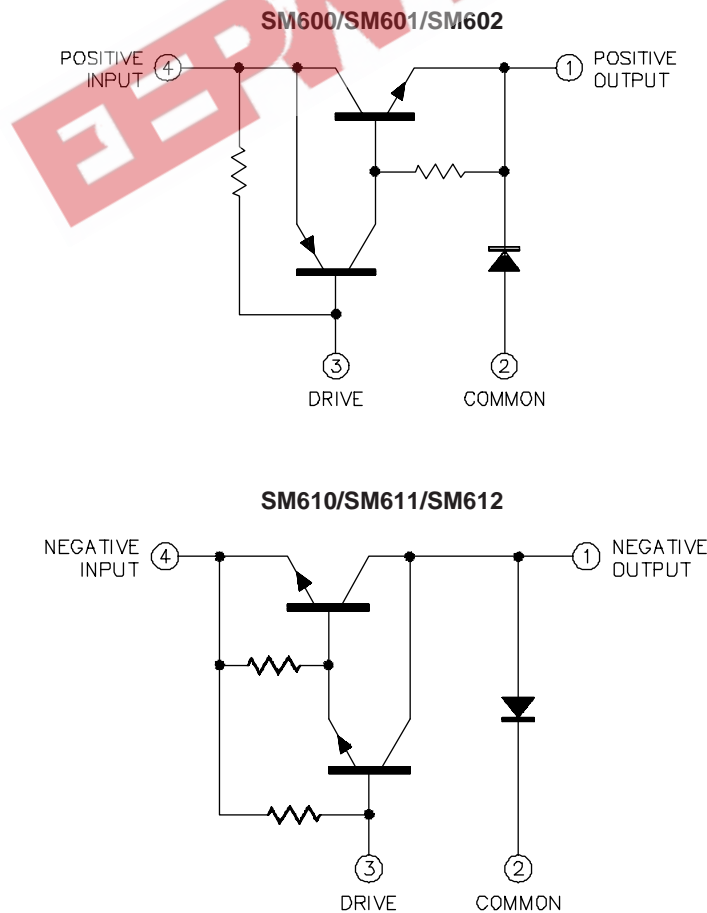

# SM600/SM601/SM602/SM610/SM611/SM612

## ABSOLUTE MAXIMUM RATINGS (Note 1)

	SM600	SM601	SM602	SM610	SM611	SM612
Input Voltage, $V_{4-2}$ .....	60V	80V	100V	-60V	-80V	-100V
Output Voltage, $V_{1-2}$ .....	60V	80V	100V	-60V	-80V	-100V
Drive Input Reverse Voltage, $V_{3-4}$ .....	5V	5V	5V	-5V	-5V	-5V
Output Current, $I_1$ .....	5A	5A	5A	-5A	-5A	-5A
Drive Current, $I_3$ .....	-0.2A	-0.2A	-0.2A	0.2A	0.2A	0.2A

### Thermal Resistance

Power Switch, $\theta_{j-c}$ .....	4.0°C/W
Commutating Diode .....	4.0°C/W
Case to Ambient, $\theta_{c-a}$ .....	60.0°C/W

### Operating Junction Temperature

Hermetic (R Package) .....	150°C
Storage Temperature Range .....	-65°C to 150°C
Lead Temperature (Soldering, 10 Seconds) .....	300°C

Note 1. Exceeding these ratings could cause damage to the device.

## THERMAL DATA

### R Package:

Thermal Resistance-Junction to Case, $\theta_{j-c}$ .....	4.0°C/W
Thermal Resistance-Junction to Ambient, $\theta_{j-a}$ .....	40°C/W

Note A. Junction Temperature Calculation:  $T_j = T_a + (P_d \times \theta_{j-a})$ .

Note B. The above numbers for  $\theta_{j-c}$  are maximums for the limiting thermal resistance of the package in a standard mounting configuration. The  $\theta_{j-a}$  numbers are meant to be guidelines for the thermal performance of the device/pc-board system. All of the above assume no ambient airflow.

## RECOMMENDED OPERATING CONDITIONS (Note 2)

	SM600	SM601	SM602	SM610	SM611	SM612
Input Voltage, $V_{4-2}$ .....	50V	70V	90V	-50V	-70V	-90V
Output Voltage, $V_{1-2}$ .....	50V	70V	90V	-50V	-70V	-90V
Drive Input Reverse Voltage, $V_{3-4}$ .....	3V	3V	3V	-3V	-3V	-3V
Output Current, $I_1$ .....	4A	4A	4A	-4A	-4A	-4A
Drive Current, $I_3$ .....	-0.1A	-0.1A	-0.1A	0.1A	0.1A	0.1A

### Operating Ambient Temperature Range

SM6XXR .....	0°C to 70°C
SM6XXHRR .....	-55°C to 125°C

Note 2. Range over which the device is functional.

## ELECTRICAL CHARACTERISTICS

(Unless otherwise specified, these specifications apply for the operating ambient temperature of  $T_a = 25^\circ\text{C}$ . Low duty cycle pulse testing techniques are used which maintains junction and case temperatures equal to the ambient temperature.)

Parameter	Test Conditions	SG600/601/602			SG610/611/612			Units
		Min.	Typ.	Max.	Min.	Typ.	Max.	
On-State Voltage (Note 3)	$I_4 = 2\text{A}(-2\text{A}), I_3 = -20\text{mA} (20\text{mA})$		1.0	1.5		-1.0	-1.5	V
	$I_4 = 5\text{A}(-5\text{A}), I_3 = -20\text{mA} (20\text{mA})$		2.5	3.5		-2.5	-3.5	V
Diode Forward Voltage (Note 3)	$I_4 = 2\text{A}(-2\text{A})$		0.8	1.0		-0.8	-1.0	V
	$I_4 = 5\text{A}(-5\text{A})$		1.0	1.5		-1.0	-1.5	V
Off-State Current	$V_4 = \text{Rated input voltage}$		0.1	10		-0.1	-10	$\mu\text{A}$
	$V_4 = \text{Rated input voltage}, T_a = 125^\circ\text{C}$			10			-10	$\mu\text{A}$
Diode Reverse Current	$V_1 = \text{Rated output voltage}$		1.0	10		-1.0	-10	$\mu\text{A}$
	$V_1 = \text{Rated output voltage}, T_a = 125^\circ\text{C}$		500			-500		$\mu\text{A}$

Note 3. Pulse test: Duration = 300 $\mu\text{s}$ , Duty Cycle  $\leq 2\%$ .

# SM600/SM601/SM602/SM610/SM611/SM612

## ELECTRICAL CHARACTERISTICS (continued)

Parameter	Test Conditions	SG600/601/602			SG610/611/612			Units
		Min.	Typ.	Max.	Min.	Typ.	Max.	
<b>Dynamic Characteristics</b> (See Figures 1 & 2) (Notes 4 & 5)								
Current Delay Time			20	40		20	40	ns
Current Rise Time			50	75		50	75	ns
Voltage Rise Time			30	50		30	50	ns
Voltage Storage Time			450			450		ns
Voltage Fall Time			50	75		50	75	ns
Current Fall Time			70	150		70	150	ns
Efficiency (Note 5)			85			85		%

## AC TEST CIRCUIT AND SWITCHING TIME WAVEFORMS (Note 6)

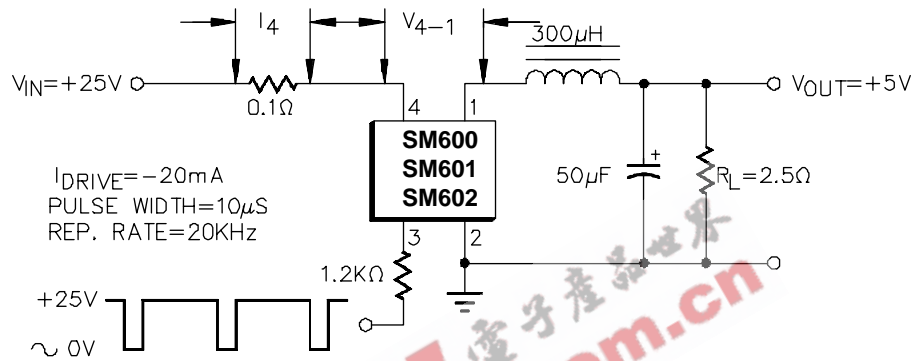

FIGURE 1 - SM600/601/602 SWITCHING SPEED CIRCUIT

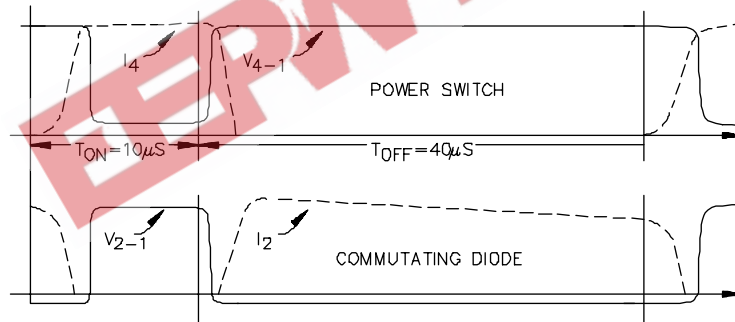

FIGURE 2 - SM600/601/602 SWITCHING WAVEFORMS

Note 4. In switching an inductive load, the current will lead the voltage on turn-on and lag the voltage on turn-off (see Figure 2). Therefore, Voltage Delay Time ( $t_{DV} \cong t_{di} + t_{ri}$ ) and Current Storage Time ( $t_{si} \cong t_{sv} + t_{iv}$ ).

Note 5. The efficiency is a measure of internal power losses and is equal to Output Power divided by Input Power. The switching speed circuit of Figure 1, in which the efficiency measured, is representative of typical operating conditions for the SM600 series switching regulators.

Note 6. SM610/611/612 Test Circuit and waveforms are identical but of opposite polarity ( $V_{IN} = -25V$ ,  $V_{OUT} = -5V$ ,  $I_{DRIVE} = +20mA$ ).

## APPLICATION CIRCUITS

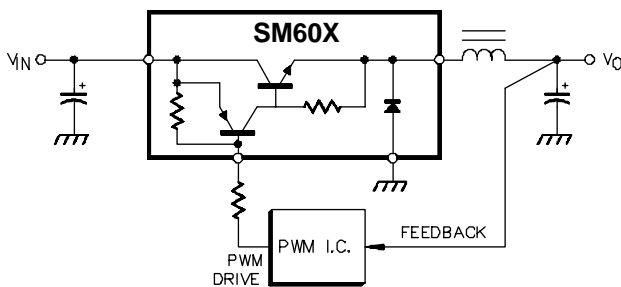

FIGURE 3 - STEP DOWN (BUCK) CONVERTER

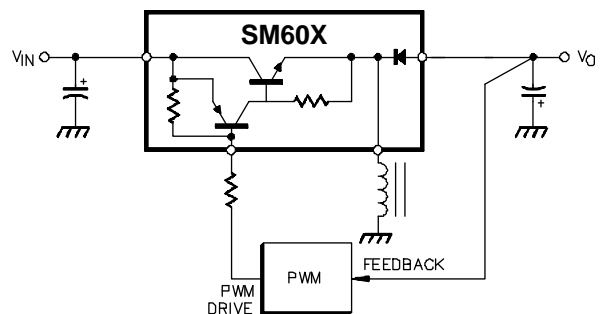

FIGURE 4 - NEGATIVE OUTPUT DOWN/UP (BUCK-BOOST) CONVERTER

# SM600/SM601/SM602/SM610/SM611/SM612

## APPLICATION CIRCUITS (continued)

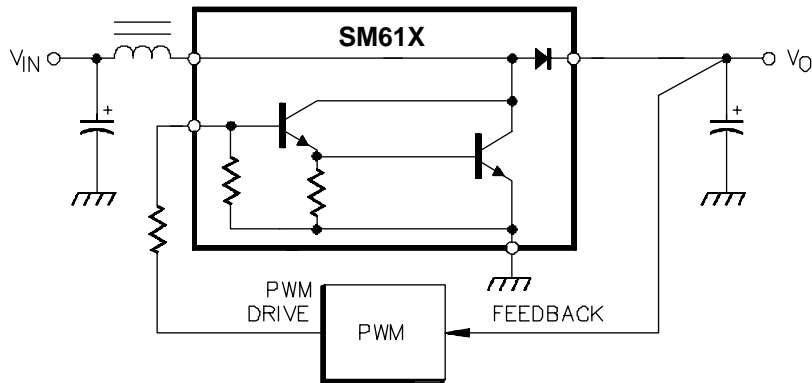

FIGURE 5 - STEP UP (BOOST) CONVERTER

## CONNECTION DIAGRAMS & ORDERING INFORMATION (See Note Below)

Package	Part No.	Ambient Temperature Range	Connection Diagram
4-PIN TO-66 METAL CAN R - PACKAGE	SM600R	0°C to 70°C	
	SM600HRR	-55°C to 125°C	
	SM601R	0°C to 70°C	
	SM601HRR	-55°C to 125°C	
	SM602R	0°C to 70°C	
	SM602HRR	-55°C to 125°C	
	SM610R	0°C to 70°C	
	SM610HRR	-55°C to 125°C	
	SM611R	0°C to 70°C	
	SM611HRR	-55°C to 125°C	
	SM612R	0°C to 70°C	
	SM612HRR	-55°C to 125°C	

- Note
1. All packages are viewed from the top.
  2. Case is electrically isolated.
  3. Consult factory for additional screening available.