

### OVERVIEW

The SM8135A is a charge pump type white LED driver. It can drive 1 to 4 backlight white LED connected in parallel, making it ideal for portable devices with small LCD. The charge pump switches between  $\times 1$  bypass mode,  $\times 1.5$  and  $\times 2$  boost mode in response to LED drive current requirements. The boost switching occurs in response to the drive current of all the connected LED and thus supports variations in LED forward-bias voltage drop (VF). Besides, the detection of switching is repeated in approx. 1sec-cycle by mode reset action, the SM8135A can respond to temporary variation of supply voltage. These ingenuities on switching detection can prolong the battery life to the fullest extent. Each LED drive current is controlled by a 4-channel LED drive current control circuit. The LED drive current per channel is setup by external resistor. Moreover, the PWM signal control of EN pin can realize nonstep brightness control (10% to 100%). The IC ON/OFF is controlled by EN pin.

### FEATURES

- Battery life extension by automatic charge pump switch between  $\times 1$ ,  $\times 1.5$  and  $\times 2$  according to the detection of the LED drive current
- Controlling 1 to 4 lights of white LED connected in parallel
- Set up LED drive current value by external resistor (120k $\Omega$ : 20mA/ch)
- 1-wire input controlling
- ON/OFF and brightness control by PWM signal controlling of EN pin (10 to 100%)
- Soft start circuit built-in
- Thermal shut down circuit built-in
- Input voltage range  
No-load current ( $I_{OUT} = 0\text{mA}$ ): 2.7 to 4.6V  
Load current ( $I_{OUT} = 80\text{mA}$ ): 3.0 to 4.6V
- Maximum output voltage: 4.9V (typ)
- Maximum output current: 80mA (typ)
- Quiescent current  
Not-switching ( $\times 1$  mode): 0.3mA (typ)  
Switching ( $\times 1.5$  mode): 1.5mA (typ)  
Switching ( $\times 2$  mode): 1.5mA (typ)
- Standby current: 0.01 $\mu\text{A}$  (typ)
- Operating frequency: 1MHz (typ)
- LED drive current accuracy between channel (REST = 120k $\Omega$ ):  $\pm 5\%$  (max)
- Package: 16-pin QFN

### APPLICATIONS

- Cellular phone
- PDA
- Portable games
- Handy terminal
- Digital still camera
- Digital video camera
- LCD panel back light
- White LED driving

### PINOUT

(Top view)

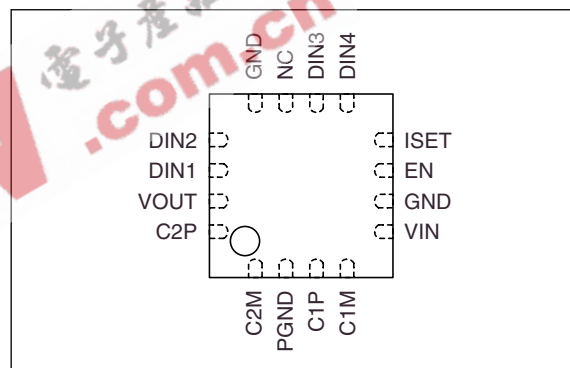

### PACKAGE DIMENSIONS

(Unit: mm)

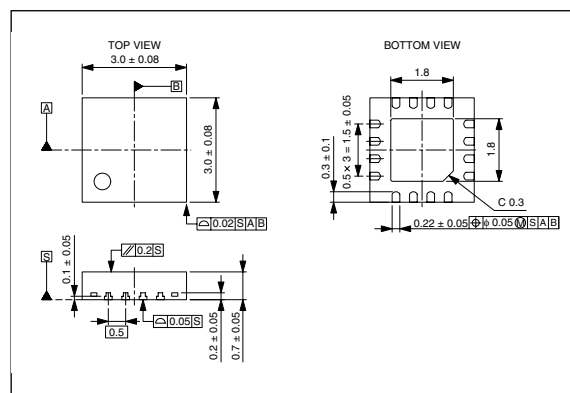

### ORDERING INFORMATION

Device	Package
SM8135AB	16-pin QFN

## BLOCK DIAGRAM

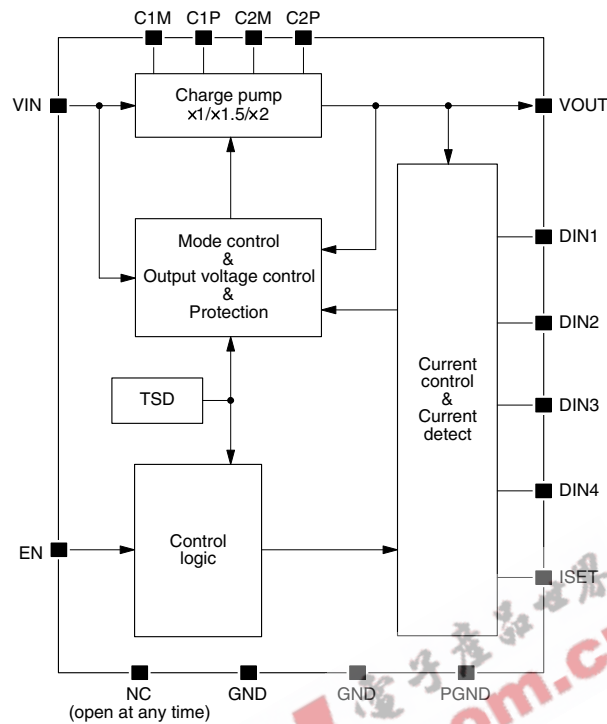

## PIN DESCRIPTION

Number	Name	I/O	Description
1	C2M	-	Charge pump boost capacitor connection 2M
2	PGND	-	Charge pump ground
3	C1P	-	Charge pump boost capacitor connection 1P
4	C1M	-	Charge pump boost capacitor connection 1M
5	VIN	-	Supply voltage input
6	GND	-	Ground
7	EN	I	Enable/PWM dimming pulse input (High active)
8	ISET	I	LED drive current setting resistor connection
9	DIN4	O	LED drive current control output 4 (connect to ground when not used)
10	DIN3	O	LED drive current control output 3 (connect to ground when not used)
11	NC	-	No connection (leave open circuit for normal operation)
12	GND	-	Ground
13	DIN2	O	LED drive current control output 2 (connect to ground when not used)
14	DIN1	O	LED drive current control output 1 (connect to ground when not used)
15	VOUT	O	LED drive voltage output
16	C2P	-	Charge pump boost capacitor connection 2P

## SPECIFICATIONS

### Absolute Maximum Ratings

GND = 0V

Parameter	Symbol	Rating	Unit
VIN voltage range	$V_{IN}$	-0.3 to 5.5	V
Input voltage range	$V_{EN}$	-0.3 to $V_{IN} + 0.3$	V
Output voltage range	$V_{DIN1 \text{ to } 4}$	-0.3 to $V_{IN} + 0.3$	V
	$V_{OUT}$	5.5	V
VOOUT output current	$I_{OUT}$	500	mA
Power dissipation	$P_D$	800 ( $T_a = 25^\circ\text{C}$ ) <sup>*1</sup>	mW
Junction temperature	$T_{JMAX}$	+125	°C
Storage ambient temperature range	$T_{stg}$	-55 to +125	°C

\*1. When mounted on a 4-layer PCB.

Note. The device may suffer breakdown if any one of these parameter ratings is exceeded.

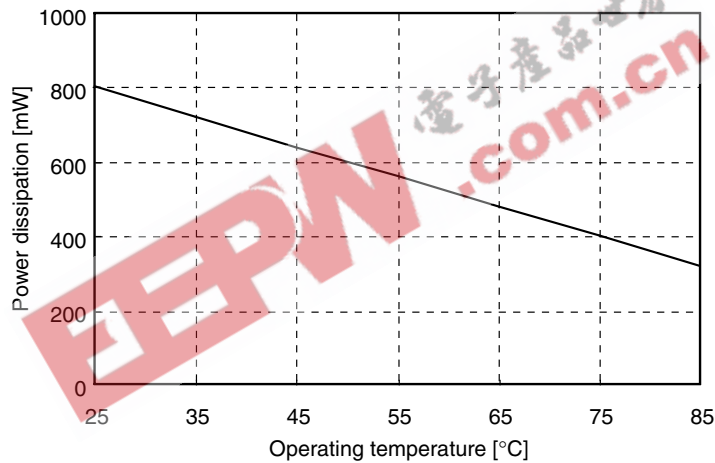

Package power dissipation when mounted on 4-layer board

### Recommended Operating Conditions

GND = 0V

Parameter	Pin	Symbol	Conditions	Rating			Unit
				min	typ	max	
Supply voltage range	VIN	$V_{IN0}$	$I_{OUT} = 0\text{mA}$	2.7	3.6	4.6	V
		$V_{IN}$	$I_{OUT} = 80\text{mA}$	3.3	3.6	4.6	V
Input voltage range	EN	$V_{ES}$	Logic-level pin	0	—	$V_{IN}$	V
Ambient temperature range	—	$T_a$		-30	—	+85	°C

## Electrical Characteristics

$V_{IN} = 3.6V$ ,  $GND = 0V$ ,  $T_a = 25^\circ C$  unless otherwise noted.

Parameter	Pin	Symbol	Condition	Rating			Unit
				min	typ	max	
Standby current	VIN	$I_{STB}$	Standby mode	–	0.01	1.00	$\mu A$
Quiescent current	VIN	$I_{DD1}$	$\times 1.0$ mode, $I_{OUT} = 0mA$	–	0.3	1.0	mA
		$I_{DD2}^{*1}$	$\times 1.5$ mode, $I_{OUT} = 0mA$	–	1.5	4.5	mA
		$I_{DD3}$	$\times 2.0$ mode, $I_{OUT} = 0mA$	–	1.5	4.5	mA
Output voltage	VOUT	$V_{OUT}$		4.4	4.9	5.4	V
Maximum output current	VOUT	$I_{OUT}$	$\times 1.5/\times 2.0$ mode	80	–	–	mA
Operating frequency	C1M	$f_{OSC}$	$\times 1.5/\times 2.0$ mode switching frequency	750	1000	1250	kHz
Internal power-ON reset time <sup>*1</sup>	EN	$T_{POR}$	Rest time from when power is applied	–	0.05	1.00	ms
Soft start time	DIN1 to 4	$T_{SS}$	EN startup $\rightarrow I_{LED}$ rising edge	0.70	1.43	3.00	ms
LED drive pin leakage current	DIN1 to 4	$I_{Leak1\ to\ 4}$	Standby mode, DIN pin = 4.9V	–	0.01	1.00	$\mu A$
LED drive current	DIN1 to 4	$I_{LED1\ to\ 4}$	$\times 1.0$ mode	18.0	20.0	22.0	mA
LED drive current matching	DIN1 to 4	$\Delta I_{LED}$	$\times 1.0$ mode, relative accuracy between channels at $I_{LED}$ maximum setting	–5.0	–	+5.0	%
LED drive pin voltage	DIN1 to 4	$V_{DIN1\ to\ 4}$	$\times 1.0$ mode	–	200	–	mV
LED drive current setting resistance <sup>*1</sup>	ISET	RSET	RSET minimum value	60	–	–	$k\Omega$
EN hold time <sup>*1</sup>	EN	$T_{CEH}$	Time from when EN = LOW until shutdown	0.50	1.00	1.50	ms
PWM input pulse frequency <sup>*1</sup>	EN	$f_{PWM}$	PWM dimming signal frequency	10	–	100	kHz
PWM input pulse duty <sup>*1</sup>	EN	$D_{PWM}$	PWM dimming signal duty range	10	–	100	%
Logic input voltage	EN	$V_{IH}$	HIGH-level input voltage range	1.4	–	–	V
		$V_{IL}$	LOW-level input voltage range	–	–	0.3	V
Logic input current	EN	$I_{IH}$	Pull-down pin, EN pin = 3.6V	–	5.0	10.0	$\mu A$
		$I_{IL}$	EN pin = 0V	–1.0	–	–	$\mu A$

\*1. Design guaranteed value

## FUNCTIONAL DESCRIPTION

### LED Drive Current Setting

The SM8135A LED drive current can be set using a combination of 2 methods: (1) current setting resistance connected to ISET, and (2) PWM signal input control on the EN pin.

#### (1) Setting LED drive current using RSET

The LED drive maximum current value per LED ( $I_{LED\ MAX}$ ) is determined by the resistor (RSET) connected to the ISET pin. The relationship between RSET and  $I_{LED\ MAX}$  is given by the following equation.

$$I_{LED\ MAX} [mA] = 2400/RSET [k\Omega]$$

(For example,  $I_{LED\ MAX} = 20mA$  when  $RSET = 120k\Omega$ .)

The RSET resistance has a minimum rating of  $60k\Omega$ . At this value of resistance, the  $I_{LED\ MAX}$  has a maximum rating of  $40mA/LED$ . However, note that the total LED drive current for all LEDs must not exceed  $80mA$ .

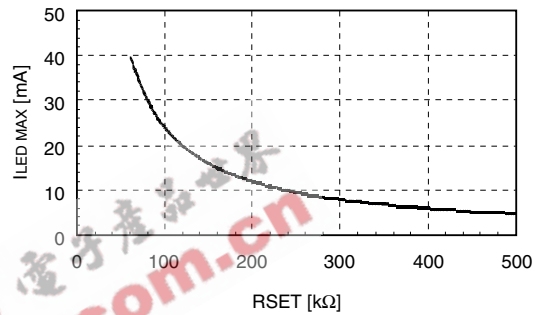
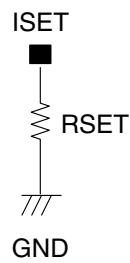

RSET vs.  $I_{LED\ MAX}$

**(2) Setting LED current using PWM signal input on EN**

The EN input is used to enable/disable circuit operation, but it can also be switched at speed using a PWM signal input to set the average LED drive current value. When using PWM signal input on EN only for dimming control, the average LED drive current is given by the multiplication of the maximum current value ( $I_{LED\ MAX}$ ) set by RSET and the PWM signal ON duty percentage.

$$I_{LED} = I_{LED\ MAX} \times \text{ON Duty [\%]}$$

The PWM signal ON duty is defined in the following figures (“PWM duty”). The PWM signal operating frequency range is 10kHz to 100kHz (10μs to 100μs per period), and the allowable duty range is 10 to 100%. However, LED drive current that can be set by PWM signal has lower limit (= 2mA). When setting current to 2mA or less, even if the signal ON duty is within the allowable range, the current between pins varies widely.

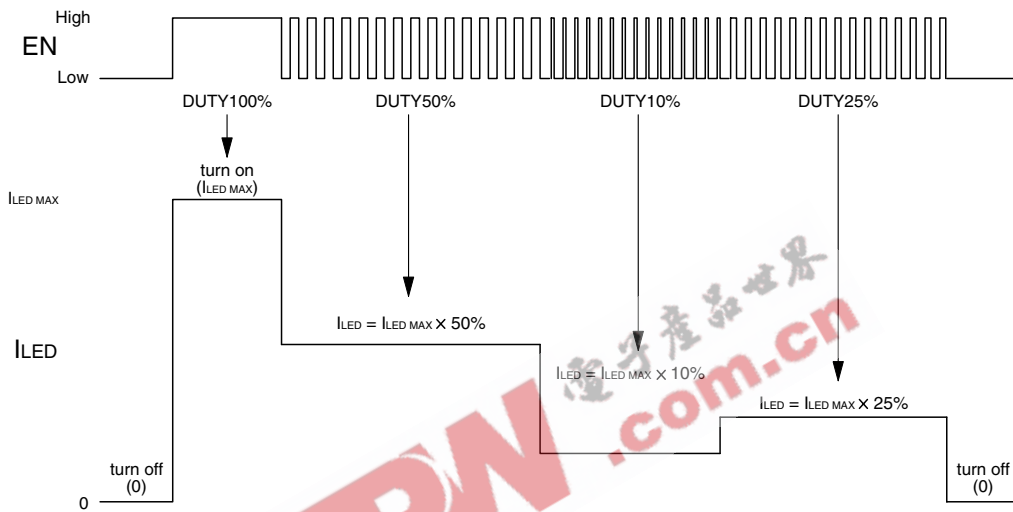

Dimming control with PWM signal

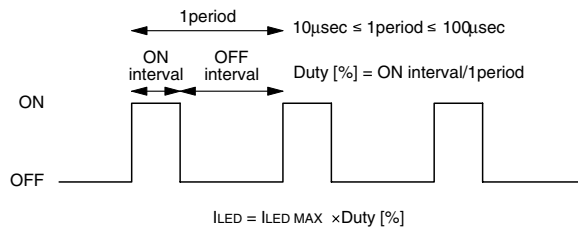

PWM duty

## V<sub>OUT</sub> Output Circuit Mode Switching

The SM8135A output mode switches between 4 operating modes in response to the operating conditions. The modes are: standby mode, ×1.0 mode (VIN through mode), ×1.5 mode (1.5-times charge pump boost), and ×2.0 mode (2.0-times charge pump boost). Specifically, the use of ×1.0 mode, ×1.5 mode, and ×2.0 mode allows the V<sub>OUT</sub> output to be adjusted automatically to match drive LED characteristics. Switching between ×1.0 mode, ×1.5 mode, and ×2.0 mode is controlled automatically by an internal circuit. The operating mode cannot be specified by an external control signal.

### Startup: Internal Reset Time and Soft Start Time

The SM8135A normal startup procedure (after V<sub>IN</sub> has been applied previously) is to switch from standby mode to the ×1.0/×1.5/×2.0 operating modes when the EN enable input goes HIGH. The soft start time (described on the following page) begins after switching to the operating mode using EN.

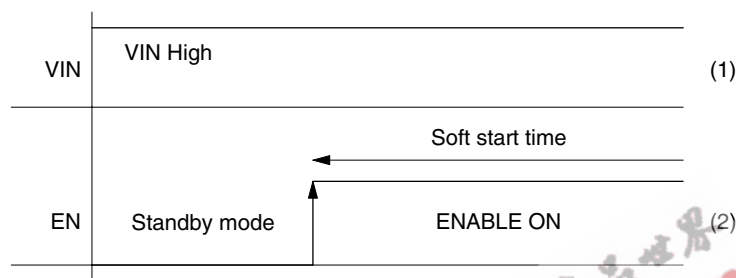

Normal startup

- (1) VIN is HIGH, EN is LOW (standby mode)
- (2) Switches to an operating mode when EN goes HIGH (soft start time begins)

If the V<sub>IN</sub> supply voltage is applied when EN is HIGH level, startup commences after the power-ON reset (POR) time (approximately 50μs) has elapsed.

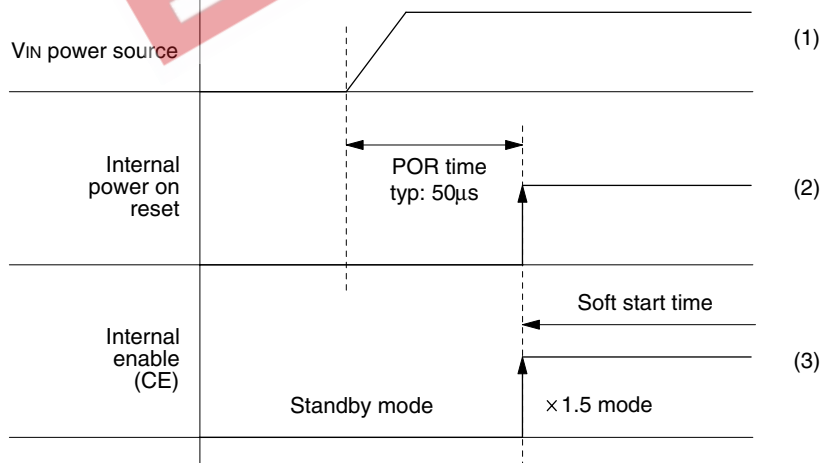

Internal reset operation when power is applied (power-ON reset)

- (1) VIN voltage rises when power is applied.
- (2) Power-ON reset (POR) circuit resets internal circuits approximately 50μs after the power is applied.
- (3) If EN is HIGH when power is applied, the internal circuits start operating when the internal “CE” signal rising edge occurs after the power-ON reset time. If EN is LOW when power is applied, the “CE” rising edge occurs simultaneously with the first rising edge.

Immediately after startup, the device operates in  $\times 1.5$  mode for a fixed interval (soft start time: approximately 1.43ms) to set the current for LEDs connected to the DIN pins. After the soft start time has elapsed, the LEDs are turned ON. Approximately 2ms is required for the LED drive current to reach the set drive value.

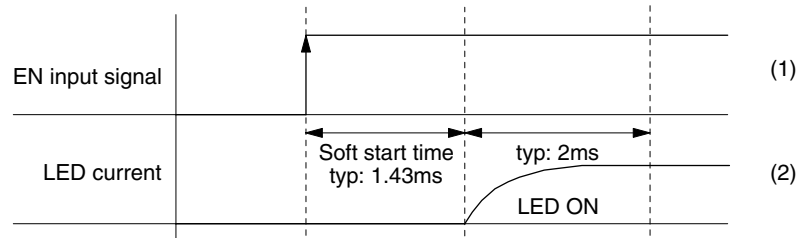

Soft start time and LED current

- (1) If the EN signal is input after power is applied, the soft start time begins on the EN rising edge. The PWM signal input for dimming is active during the soft start time.
- (2) After the soft start time (1.43ms) has elapsed, the LEDs are turned ON. Approximately 2ms is required for LED drive current to reach set values.

### Switching to Standby Mode

The SM8135A switches from  $\times 1.0/\times 1.5/\times 2.0$  mode to standby mode if EN goes LOW and stays LOW for an interval of 1.00ms (typ). This function is used to switch the internal circuits to standby mode automatically when the LEDs turn OFF in order to reduce current consumption.

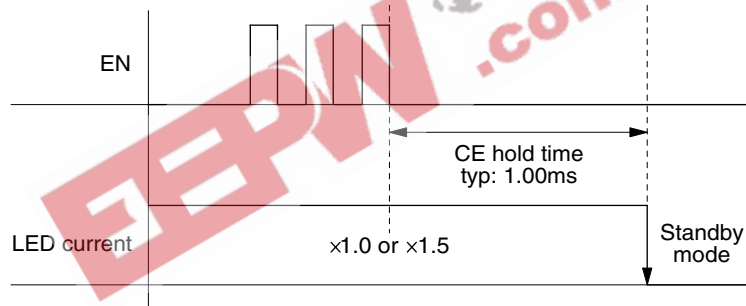

EN input signal and internal enable signal "CE"

- If EN is LOW for longer than the enable hold time of 1.00ms (typ), the SM8135A switches to standby mode. In standby mode, the internal circuits are reset.



### Boost Mode Auto-switching

The SM8135A switches between  $\times 1.0$  mode (VIN through mode),  $\times 1.5$  mode (1.5-times charge pump boost), and  $\times 2.0$  mode (2.0-times charge pump boost) automatically in response to the operating state to reduce current consumption. The switching transition flow chart is shown in the following figure.

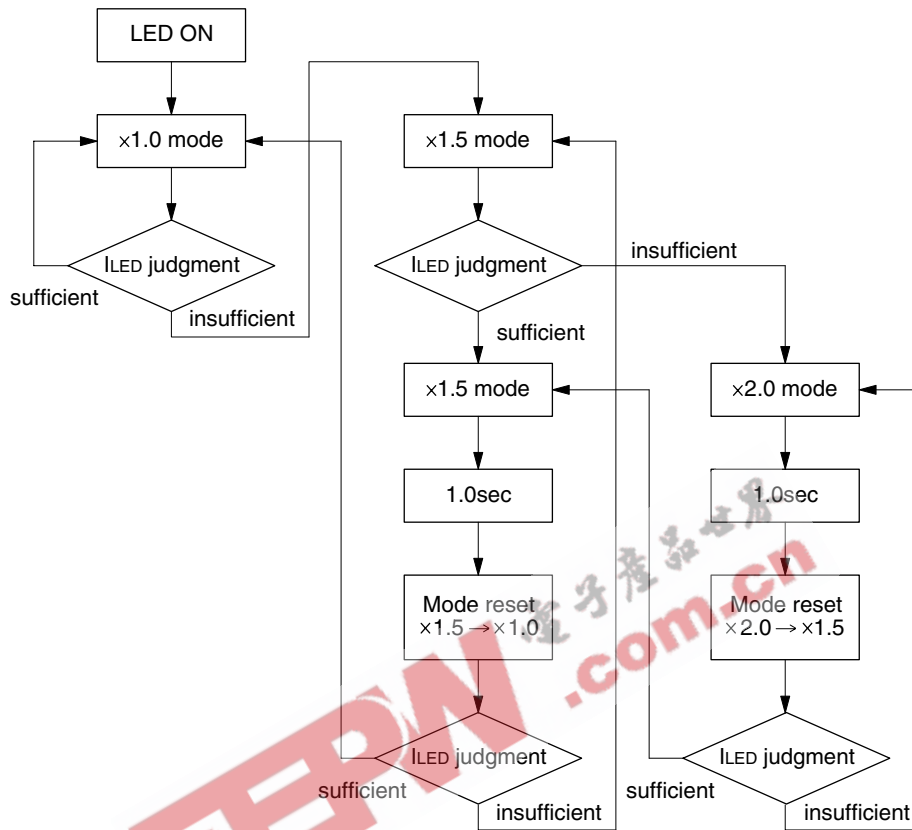

Boost mode switching flow chart

This section describes the boost mode switching in response to insufficient LED drive current level detection. The next section describes the mode reset functions. Initially, when the LED drive current begins to flow, operation begins in  $\times 1.0$  mode at the set current value if possible, without boosting the input voltage VIN. If the set current value cannot be attained in  $\times 1.0$  mode due to a VIN voltage drop or an increase in the set current value, a low-current detector circuit connected to each LED drive circuit is activated that switches the VOUT output to  $\times 1.5$  mode automatically, and the charge pump circuit starts boosting the voltage by 1.5 times. If the set current value still cannot be attained, the LED drive circuits are switched to  $\times 2.0$  mode, and the charge pump starts boosting the voltage by 2 times.

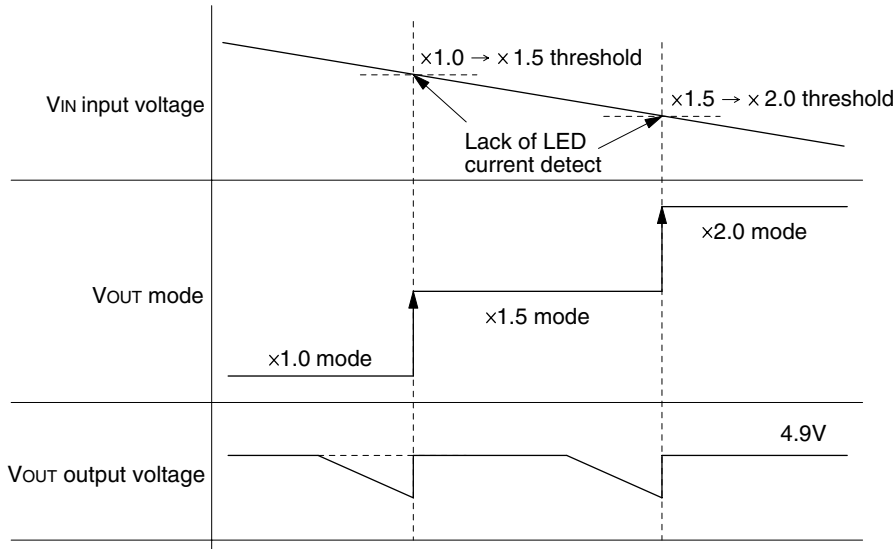

$V_{IN}$  voltage drop and  $V_{OUT}$  output voltage

In  $\times 1.0$  mode,  $V_{IN} = V_{OUT}$ . However, the  $V_{OUT}$  output does not always reach the electrical characteristics typical rating of 4.9V. However, as long as an insufficient current condition is not detected,  $\times 1.0$  mode operation continues. In other words,  $V_{OUT}$  may drop below 4.9V if sufficient LED drive current is flowing to counter the LED forward-bias voltage  $V_F$ . The longer the device can operate in the high output efficiency  $\times 1.0$  mode, the lower the total current consumption and the longer the battery drive time can be extended. Furthermore, the more that low  $V_F$  LEDs and lower LED drive current are used, the longer the device can operate automatically in  $\times 1.0$  mode.

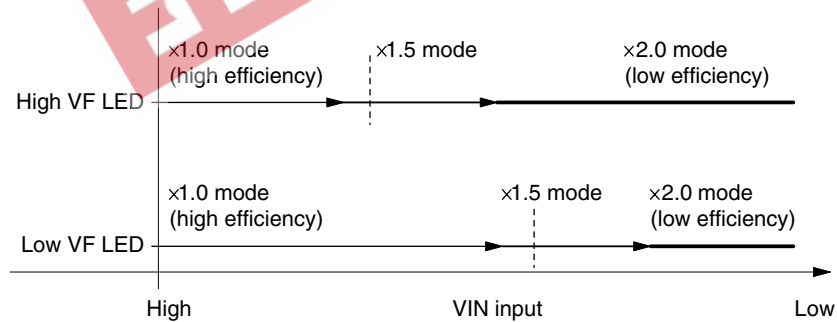

$V_{OUT}$  mode switching time comparison due to drive LED “VF” variation

The LED low-current detector circuit switches the output boost mode whenever a single insufficient current condition is detected among the 4 channel LED drive currents, hence drive LEDs with small  $V_F$  variation should be used to increase overall efficiency. If, after startup, a LED connection to the DIN pins is switched ON/OFF, the LED current detection circuit will operate incorrectly and normal boost mode switching does not occur. Also, if LED drive current control using a DIM pin is not used, the low-current detector circuit does not operate and the boost mode does not switch to either  $\times 1.5$  or  $\times 2.0$  mode.

### Mode Reset Function

$V_F$  increases immediately after the LED current starts to flow, and then decreases as the LED temperature increases due to the heating effect of the current flow. It can take about 10 seconds for the LED temperature to stabilize and for  $V_F$  to reach equilibrium, and  $V_F$  may fluctuate more than 200mV. The  $V_F$  fluctuation is affected by the ambient temperature and LED current setting, and has a large affect on the automatic mode switching voltage tolerances. To counter the effects of  $V_F$  fluctuation, the SM8135A outputs a mode reset signal once every 1.0 seconds which automatically switches the output mode to  $\times 1.0$ , and then a determination is made whether to make the  $\times 1.0 \rightarrow \times 1.5$  mode switch.

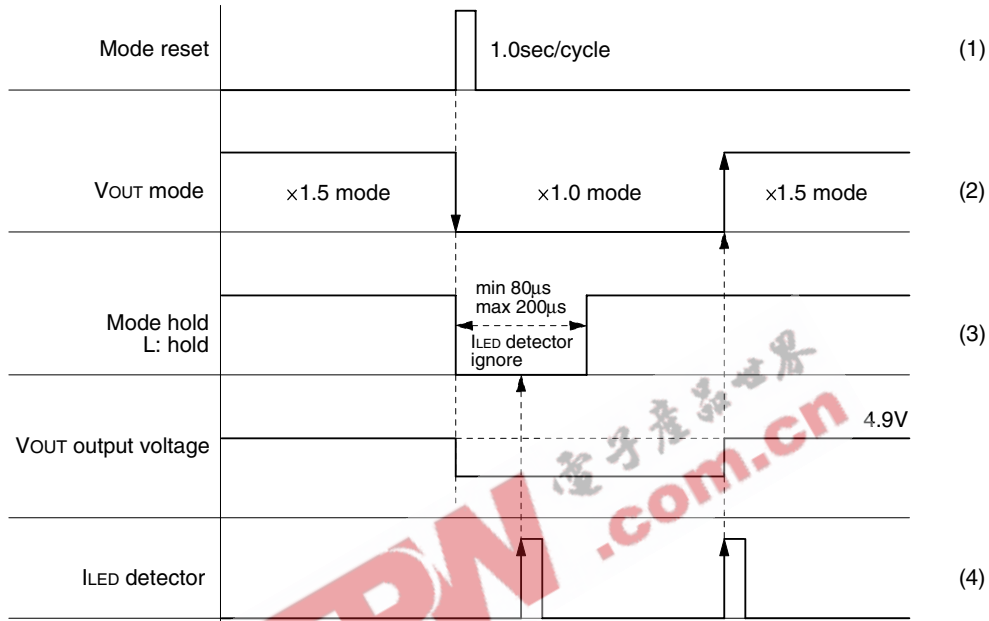

Switching from  $\times 1.5$  mode to  $\times 1.0$  mode due to mode reset signal

- (1) Mode reset signal is output once every 1.0 seconds.
- (2) Mode switches from  $\times 1.5$  to  $\times 1.0$  mode on the rising edge of the mode reset signal.
- (3) A 200 $\mu$ s (max) mode hold time begins after switching to  $\times 1.0$  mode. LED drive current insufficient state is detected but the mode is not switched during this interval.
- (4) LED drive current insufficient signal is ignored during the mode hold time, but normal mode switching operation resumes when the mode hold time elapses.

A mode hold signal of 200 $\mu$ s (max) duration is output immediately after switching to  $\times 1.0$  mode. The  $V_{OUT}$  output is held in  $\times 1.0$  mode and any LED drive current insufficient detection signal is ignored during the mode hold signal output. For example, if the  $V_{IN}$  voltage drops and the  $V_{OUT}$  output voltage in  $\times 1.0$  mode cannot provide sufficient current to drive the LEDs, a LED drive current insufficient condition occurs momentarily due to the mode reset. The LED low-current detector circuit outputs a LED drive current insufficient signal immediately after switching modes, but during the mode hold time the device stays in  $\times 1.0$  mode and does not switch to  $\times 1.5$  mode. Consequently, the  $V_{OUT}$  voltage drops and the LED brightness decreases during the 85 $\mu$ s (min) to 200 $\mu$ s (max) mode hold time. However, a 200 $\mu$ s decrease in the brightness is not a problem as it is not perceptible to the human eye.

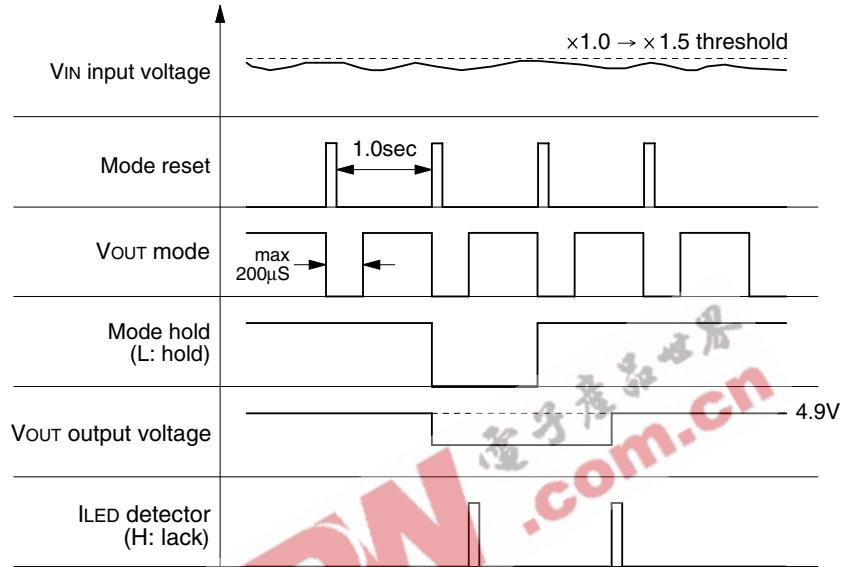

$V_{OUT}$  drop due to mode reset signal (between  $\times 1.5$  and  $\times 1.0$  mode)

The mode reset operation when in  $\times 2.0$  mode performs boost mode switching between  $\times 2.0$  mode and  $\times 1.5$  mode. Mode switching directly from  $\times 2.0$  mode to  $\times 1.0$  mode does not occur.

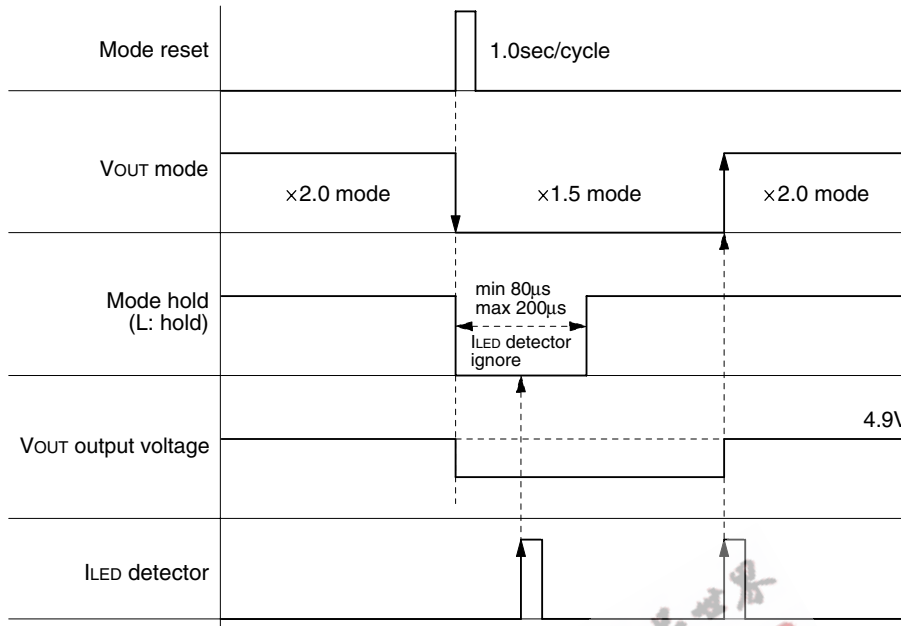

Switching from  $\times 2.0$  mode to  $\times 1.5$  mode due to mode reset signal

- (1) Mode switches from  $\times 2.0$  to  $\times 1.5$  mode on the rising edge of the mode reset signal.
- (2) A 200 $\mu$ s (max) mode hold time begins after switching to  $\times 1.5$  mode. LED drive current insufficient state is detected but the mode is not switched during this interval.
- (3) LED drive current insufficient signal is ignored during the mode hold time, but normal mode switching operation resumes when the mode hold time elapses.

The mode reset function periodically tests the boost mode to try to maximize the duration of operation in the higher efficiency  $\times 1.0$  and  $\times 1.5$  modes in order to extend battery drive time.

### Thermal Shutdown Circuit (Overtemperature Protection Circuit)

The SM8135A features a thermal shutdown circuit that operates whenever the IC temperature exceeds approximately 170°C for whatever reason, stopping the V<sub>OUT</sub> output. V<sub>OUT</sub> output recommences when the IC temperature falls below approximately 150°C.

## PERIPHERAL PARTS

### About the External Capacitors

The best capacitors for use with the SM8135A are multi-layer ceramic capacitors. When selecting a multi-layer ceramic capacitor, only X5R and X7R dielectric types are strongly recommended, since the loss of capacitance in various conditions is less than other types such as Z5U and Y5V. The much loss of capacitance in various conditions may cause the output voltage unstable.

Table. The EIA three digit "TC" code

Lower temperature limit	High temperature limit	Maximum allowable capacitance change from +25°C (0V DC)
X = -55°C	5 = +85°C	F = ± 7.5%
Y = -30°C	6 = +105°C	P = ± 10%
Z = +10°C	7 = +125°C	R = ± 15%
	8 = +150°C	S = ± 22%
		T = +22%/-33%
		U = +22%/-56%
		V = +22%/-82%

For example

: X5R

### About the Input Capacitor "C4"

The parts layout of PCB may merely cause the "V<sub>OUT</sub>" output voltage unstable. In this case, increasing the "C4" input capacitance value or adding another capacitor on the VIN input line is effective to solve the unstable output voltage.

## TYPICAL APPLICATION CIRCUITS

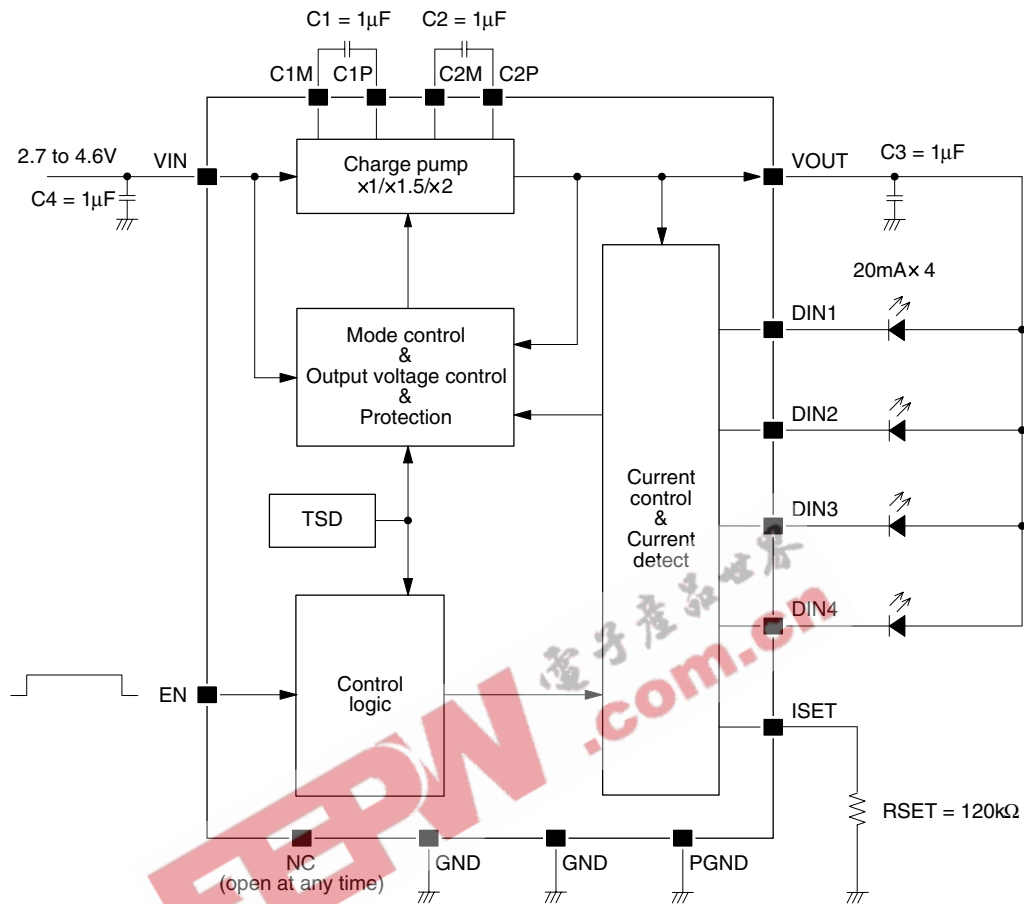
LED  $\times$  4,  $I_{LED} = 20mA$ , without Dimming

Note. If the driving LED is less than 4 pcs, unused DIN pins should be connect to GND.

ON/OFF control is performed using Enable signal input on EN with a fixed LED current determined by resistor RSET.



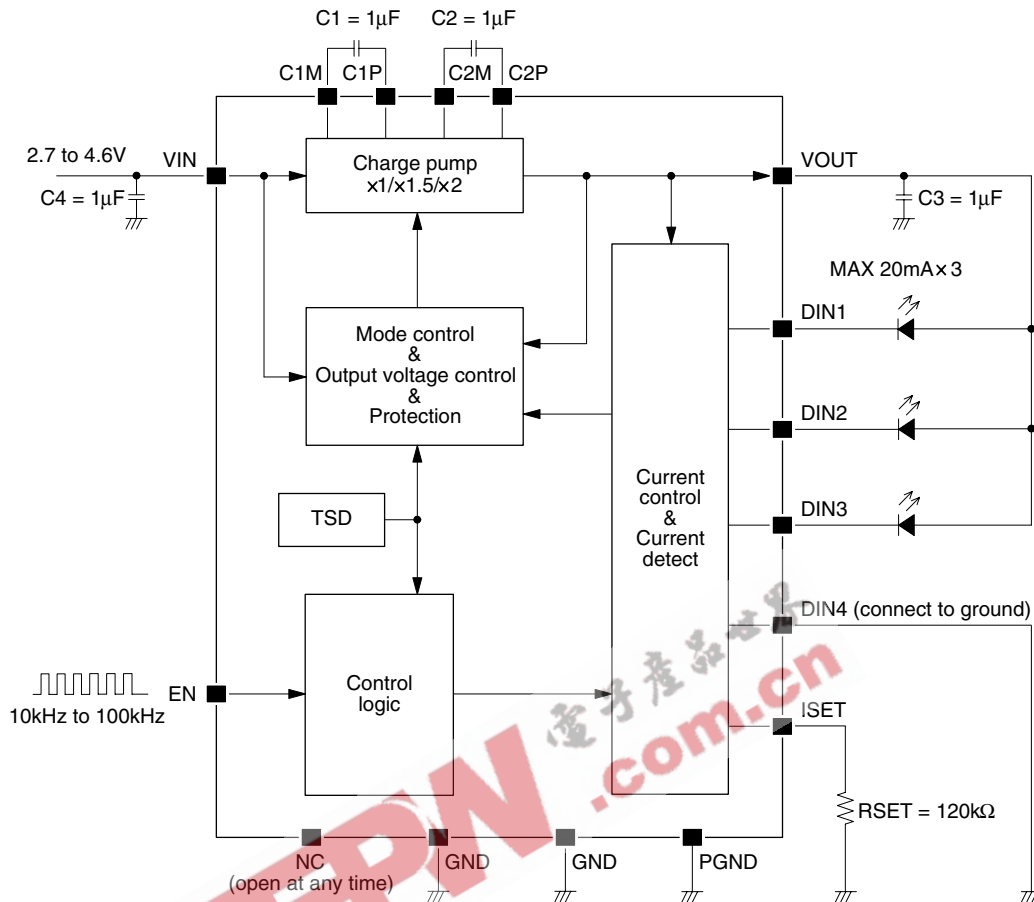

LED × 3,  $I_{LED\ MAX} = 20mA$ , PWM Pulse Input Dimming on EN

Note. If the driving LED is less than 4 pcs, unused DIN pins should be connect to GND.

Dimming and ON/OFF control is performed using PWM pulse input on EN with a maximum LED current determined by resistor RSET (see P.6 "Setting LED current using PWM signal input on EN").

The PWM control signal duty ratio must be in the range 10 to 100% (see "Electrical Characteristics").

The PWM control signal frequency must be in the range 10kHz to 100kHz (see "Electrical Characteristics").

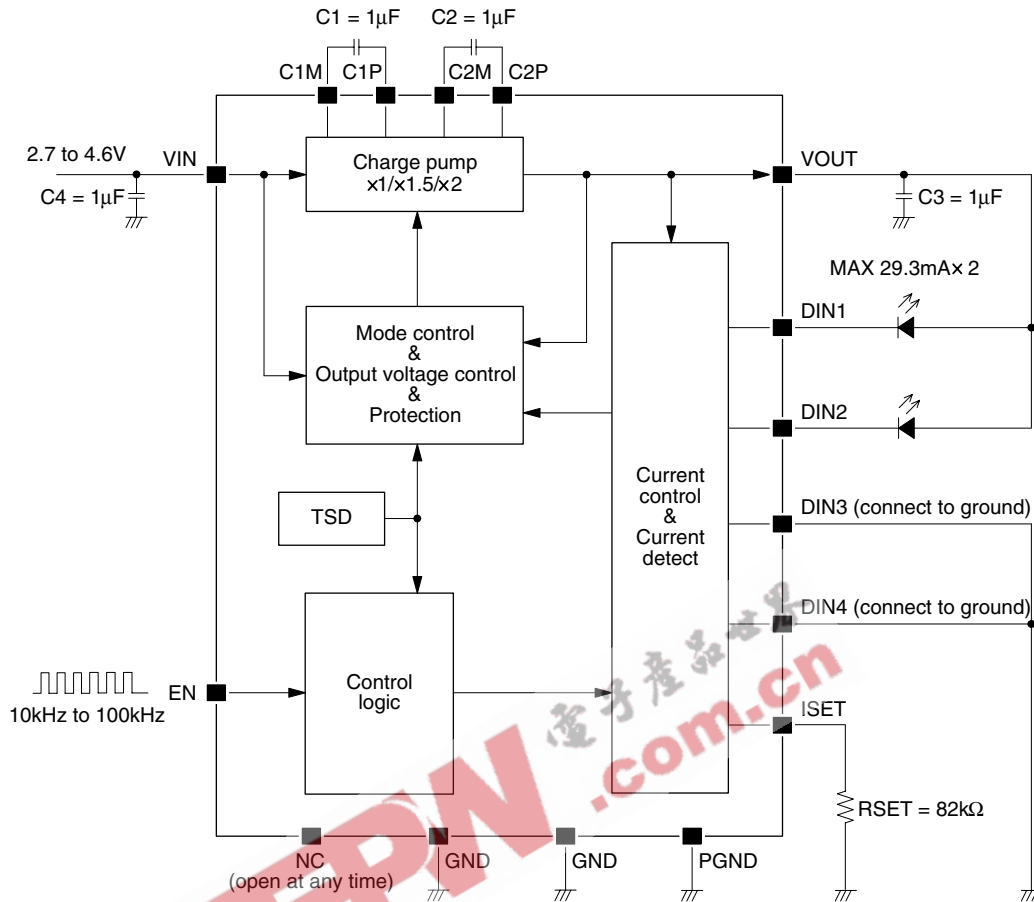
LED × 2,  $I_{LED\ MAX} = 29.3mA$ , PWM Pulse Input Dimming on EN

Note. If the driving LED is less than 4 pcs, unused DIN pins should be connect to GND.

Dimming and ON/OFF control is performed using PWM pulse input on EN with a maximum LED current determined by resistor RSET (see P.6 "Setting LED current using PWM signal input on EN").

The PWM control signal duty ratio must be in the range 10 to 100% (see "Electrical Characteristics").

The PWM control signal frequency must be in the range 10kHz to 100kHz (see "Electrical Characteristics").

FOOTPRINT PATTERN

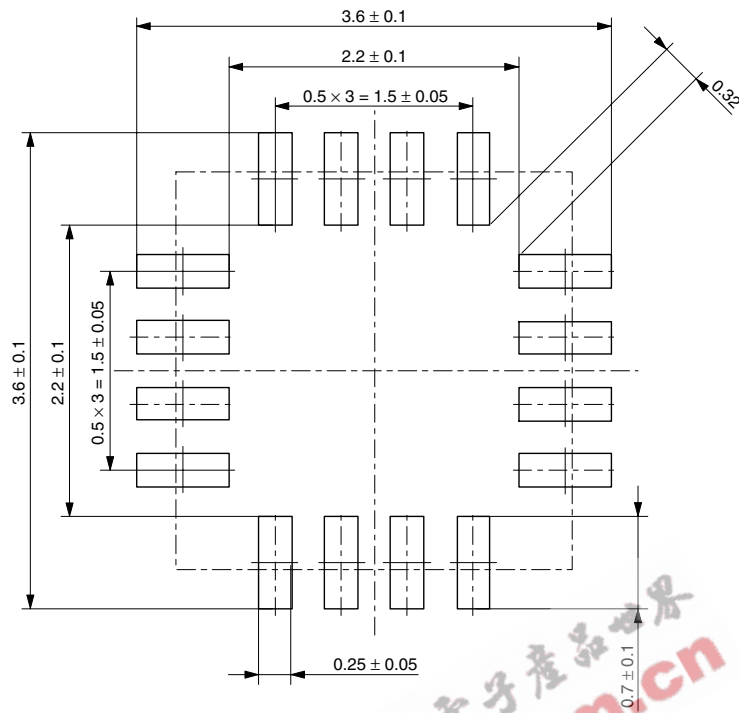

EEPW 电子产品世界  
.com.cn

Please pay your attention to the following points at time of using the products shown in this document.

The products shown in this document (hereinafter "Products") are not intended to be used for the apparatus that exerts harmful influence on human lives due to the defects, failure or malfunction of the Products. Customers are requested to obtain prior written agreement for such use from SEIKO NPC CORPORATION (hereinafter "NPC"). Customers shall be solely responsible for, and indemnify and hold NPC free and harmless from, any and all claims, damages, losses, expenses or lawsuits, due to such use without such agreement. NPC reserves the right to change the specifications of the Products in order to improve the characteristic or reliability thereof. NPC makes no claim or warranty that the contents described in this document dose not infringe any intellectual property right or other similar right owned by third parties. Therefore, NPC shall not be responsible for such problems, even if the use is in accordance with the descriptions provided in this document. Any descriptions including applications, circuits, and the parameters of the Products in this document are for reference to use the Products, and shall not be guaranteed free from defect, inapplicability to the design for the mass-production products without further testing or modification. Customers are requested not to export or re-export, directly or indirectly, the Products to any country or any entity not in compliance with or in violation of the national export administration laws, treaties, orders and regulations. Customers are requested appropriately take steps to obtain required permissions or approvals from appropriate government agencies.

**NPC**

**SEIKO NPC CORPORATION**

15-6, Nihombashi-kabutocho, Chuo-ku,  
Tokyo 103-0026, Japan  
Telephone: +81-3-6667-6601  
Facsimile: +81-3-6667-6611  
<http://www.npc.co.jp/>  
Email: [sales@npc.co.jp](mailto:sales@npc.co.jp)

NC0602AE 2007.01