

Low Resistance Low Capacitance Plastic Packaged PIN Diodes



SMP1320 Series

Features

- Designed for High Performance Wireless Switch Applications
- 0.9 Ω Resistance, 0.3 pF Capacitance
- Multiple Package Configurations
- Available in Tape and Reel Packaging

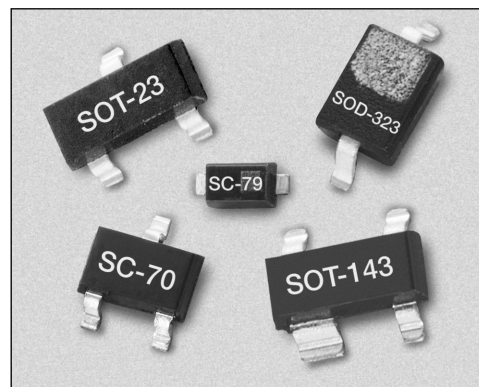

Description

The SMP1320 series of plastic packaged, surface mountable PIN diodes are designed for high volume switch applications from 10 MHz to beyond 2 GHz. The low current performance of these diodes (0.9 Ω maximum at 10 mA and 2 Ω typical at 1 mA) make the SMP1320 series particularly suited to battery operated circuits. Available in a selection of plastic packages and in a variety of configurations including a low inductance (0.4 nH) SOT-23 (SMP1320-007), the small footprint SC-79 and the miniature SC-70.

Absolute Maximum Ratings

Characteristic	Value
Reverse Voltage (V_R)	50 V
Power Dissipation @ 25°C Lead Temperature (P_D)	250 mW
Storage Temperature (T_{ST})	-65°C to +150°C
Operating Temperature (T_{OP})	-65°C to +150°C
ESD Human Body Model	Class 1B

Symbol	Symbol	Symbol	Symbol	Symbol	Symbol	Symbol
Single	Common Cathode	Series Pair	Low Inductance	Single	Ultra Low Inductance	Single
Marking: PL1	Marking: PL3	Marking: PL2	Marking: PLB		Marking: PLC	
SOT-23	SOT-23	SOT-23	SOT-23	SOD-323	SOT-143	SC-79
† SMP1320-001	† SMP1320-004	† SMP1320-005	† SMP1320-007	† SMP1320-011	† SMP1320-017	† SMP1320-079
$L_S = 1.5$ nH	$L_S = 1.5$ nH	$L_S = 1.5$ nH	$L_S = 0.4$ nH	$L_S = 1.5$ nH	$L_S = 0.2$ nH	$L_S = 0.7$ nH
	SC-70	SC-70	SC-70			
	† SMP1320-074	† SMP1320-075	† SMP1320-077			
	$L_S = 1.4$ nH	$L_S = 1.4$ nH	$L_S = 0.4$ nH			

† Available through distribution.

Electrical Specifications at 25°C

Parameter	Condition	Typ.	Max.	Unit
Reverse Current (I_R)	$V_R = 50$ V		10	μ A
Capacitance (C_T)	$F = 1$ MHz, $V = 30$ V		0.30	pF
Resistance (R_S)	$F = 100$ MHz, $I = 1$ mA	2.0		Ω
Resistance (R_S)	$F = 100$ MHz, $I = 10$ mA		0.9	Ω
Forward Voltage (V_F)	$I_F = 10$ mA	0.85		V
Carrier Lifetime (TI)	$I_F = 10$ mA	0.4		μ S
I Region Width		8		μ m

Typical Performance Data

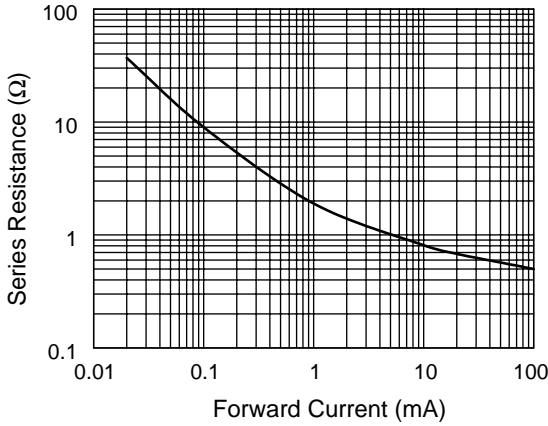

Series Resistance vs. Current @ 100 MHz

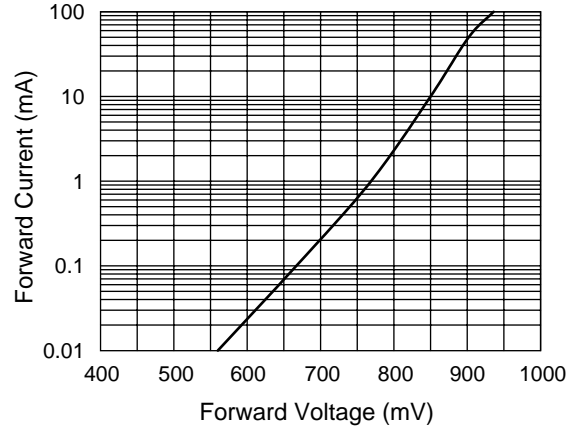

DC Characteristic

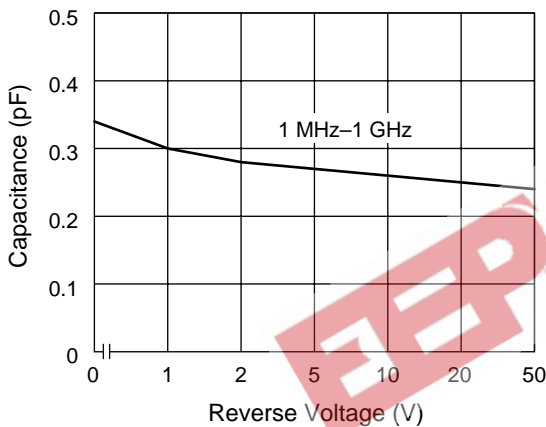

Capacitance vs. Reverse Voltage

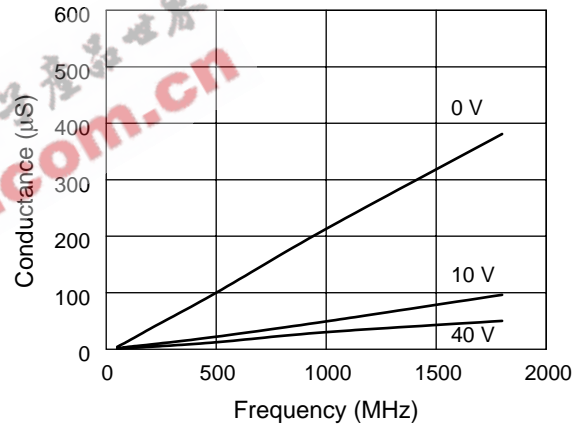

Conductance vs. Frequency and Reverse Voltage

Resistance vs. Temperature @ 500 MHz

I_F (mA)	R_S -55°C (Ω)	R_S -15°C (Ω)	R_S +25°C (Ω)	R_S +65°C (Ω)	R_S +100°C (Ω)
0.02	29.60	29.20	30.80	32.00	32.70
0.10	7.20	7.70	8.30	8.80	8.80
0.30	3.40	3.60	3.80	4.00	4.10
0.50	2.50	2.70	2.80	2.90	3.00
1.00	1.70	1.80	1.90	2.00	1.90
10.00	0.84	0.85	0.76	0.76	0.67
20.00	0.73	0.73	0.64	0.64	0.56
100.00	0.59	0.57	0.47	0.48	0.40

SMP1320-007

In the -007 configuration of the SOT-23 package, the package inductance is effectively reduced to 0.4 nH, in comparison to the 1.5 nH value of the standard configuration. This lower inductance will be particularly beneficial when the diodes are used as shunt connected switches at frequencies higher than 500 MHz, where inductance is the primary limitation on maximum switch isolation.

To achieve the effective 0.4 nH, the SOT-23 package must be inserted in the microstrip circuit board with a gap in the trace, as shown in the figure. Because of the polarity of the diode junction, this low inductance feature is only realizable with the cathode connected to ground.

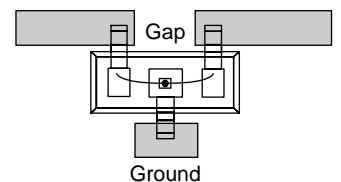

SOT-23

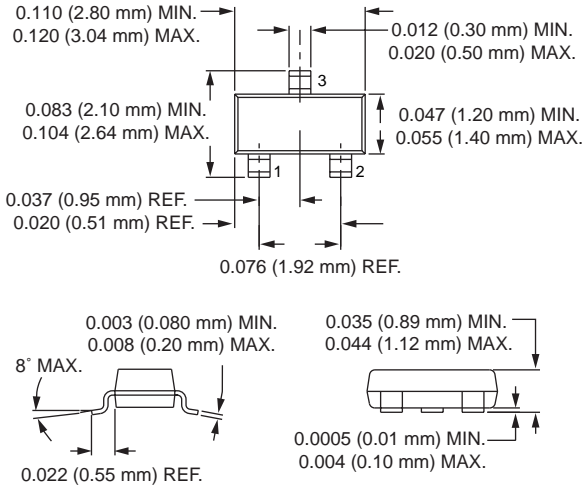

SC-70

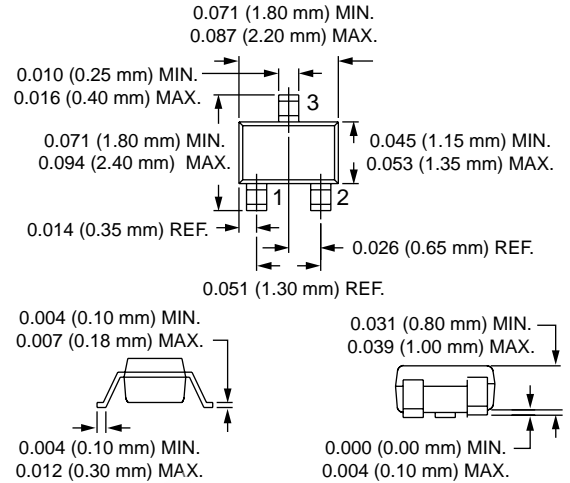

SOD-323

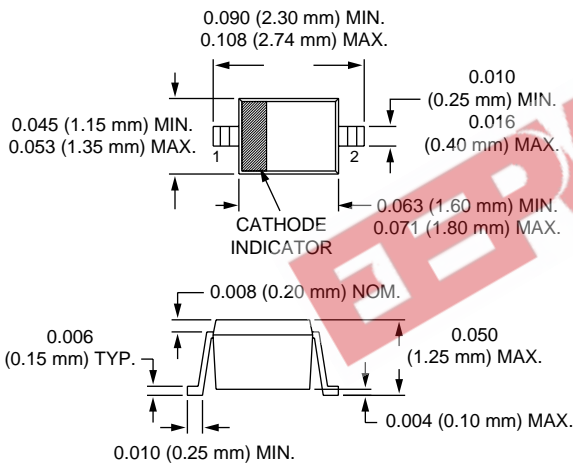

SC-79

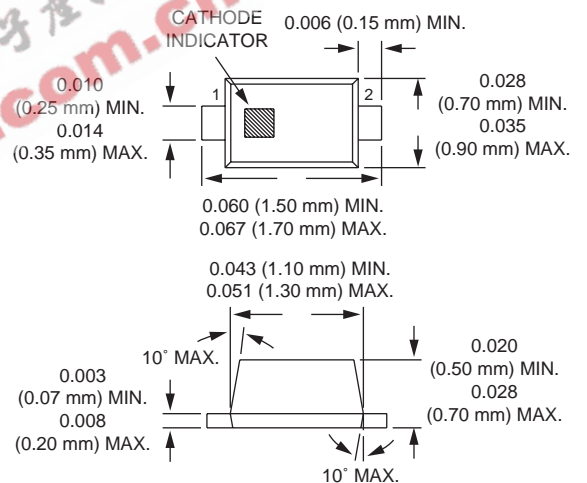

SOT-143

