

# Honeywell

## Interactive Catalog Replaces Catalog Pages

Honeywell Sensing and Control has replaced the PDF product catalog with the new **Interactive Catalog**. The **Interactive Catalog** is a power search tool that makes it easier to find product information. It includes more installation, application, and technical information than ever before.



Click this icon to try the new Interactive Catalog.



Sensing and Control  
Honeywell Inc.  
11 West Spring Street  
Freeport, Illinois 61032

電子產品世界  
-com.cn

# Solid State Sensors

## Surface Mount Digital Position Sensors

SS100 Series



### FEATURES

- Quad Hall design virtually eliminates mechanical stress effects
- Temperature compensated magnetics
- Bipolar, unipolar, latching magnetics
- Super high sensitivity available
- Symmetry of operate/release points about zero gauss (bipolar/latching)
- Operating temperature range of -40 to +125°C
- Low current consumption (7 mA typical @ 5 V, 25°C)
- 3.8 to 30 VDC supply voltage range
- High output current capability of 50 mA absolute maximum

The temperature compensated Hall effect sensor consists of a quad Hall sensing element in a square integrated circuit chip, which is then encapsulated in a glass-filled thermoset molding material. The small SOT89 style package surface mounts on PC boards and flexible circuits.

The integrated circuit is thermally balanced for predictable performance over the full temperature range of -40 to +125°C. Built-in temperature compensation has a negative slope (operate and release points decrease as temperature increases). This slope is optimized to match the negative temperature coefficient of low cost magnets, to track their performance over temperature. Bipolar, unipolar and latching magnetics are available.

Band gap regulation provides extremely stable operation over the full supply voltage range of 3.8 to 30 VDC. Current consumption is a low 10 mA maximum. SS100 sensors are capable of continuous 20 mA sinking output, and can withstand temporary current as high as 50 mA absolute maximum. They can use existing power supply sources in most applications, and can be directly interfaced with many electronic components without buffering or compensation circuitry. SS100 Series sensors are available on tape and reel for high-volume, automated pick and place equipment. Each reel contains 1,000 sensors.

**NOTE: DO NOT wave solder this product.** This process may negatively affect sensor performance and reliability, and will void MICRO SWITCH's warranty. MICRO SWITCH recommends a convection infrared reflow process with peak temperatures not to exceed 220°C (428°F) for 10 seconds maximum.

### ORDER GUIDE

Catalog Listing	SS111A	SS113A	SS141A	SS143A	SS149A	SS161A	SS166A
Magnetic Type	Bipolar	Bipolar	Unipolar	Unipolar	Unipolar	Latching	Latching
Supply Voltage (VDC)	3.8 to 30	3.8 to 30	3.8 to 30	3.8 to 30	3.8 to 30	3.8 to 30	3.8 to 30
Supply Current (max.)	10 mA	10 mA	10 mA	10 mA	10 mA	10 mA	10 mA
Output Type	Sink	Sink	Sink	Sink	Sink	Sink	Sink
Output Voltage (max.)	.40 V	.40 V	.40 V	.40 V	.40 V	.40 V	.40 V
Output Current (max.)	20 mA	20 mA	20 mA	20 mA	20 mA	20 mA	20 mA
Leakage Current (max.)	10 µA	10 µA	10 µA	10 µA	10 µA	10 µA	10 µA
Output Switching Time Rise (10-90%) (max.) Fall (90-10%) (max.)	1.5 µs 1.5 µs	1.5 µs 1.5 µs	1.5 µs 1.5 µs	1.5 µs 1.5 µs	1.5 µs 1.5 µs	1.5 µs 1.5 µs	1.5 µs 1.5 µs
Magnetic Characteristics* -40°C	G mT	G mT	G mT	G mT	G mT	G mT	G mT
Max. Op.	70 7.0	140 14.0	135 13.5	215 21.5	440 44.0	110 11.0	200 20.0
Min. Rel.	-70 -7.0	-140 -14.0	20 2.0	80 8.0	210 21.0	-110 -11.0	-200 -20.0
Min. Dif.	15 1.5	20 2.0	15 1.5	25 2.5	30 3.0	50 5.0	200 20.0
0°C							
Max. Op.	65 6.5	140 14.0	117 11.7	190 19.0	400 40.0	90 9.0	185 18.5
Min. Rel.	-65 -6.5	-140 -14.0	20 2.0	80 8.0	230 23.0	-90 -9.0	-185 -18.5
Min. Dif.	15 1.5	20 2.0	18 1.8	25 2.5	30 3.0	50 5.0	200 20.0
25°C							
Max. Op.	60 6.0	140 14.0	115 11.5	180 18.0	390 39.0	85 8.5	180 18.0
Min. Rel.	-60 -6.0	-140 -14.0	20 2.0	75 7.5	235 23.5	-85 -8.5	-180 -18.0
Min. Dif.	15 1.5	20 2.0	20 2.0	25 2.5	30 3.0	50 5.0	200 20.0
85°C							
Max. Op.	60 6.0	140 14.0	120 12.0	180 18.0	400 40.0	85 8.5	180 18.0
Min. Rel.	-60 -6.0	-140 -14.0	15 1.5	70 7.0	215 21.5	-85 -8.5	-180 -18.0
Min. Dif.	12 1.2	20 2.0	15 1.5	15 1.5	30 3.0	50 5.0	190 19.0
125°C							
Max. Op.	65 6.5	140 14.0	123 12.3	190 19.0	410 41.0	100 10.0	180 18.0
Min. Rel.	-65 -6.5	-140 -14.0	15 1.5	60 6.0	200 20.0	-100 -10.0	-180 -18.0
Min. Dif.	12 1.2	20 2.0	8 0.8	10 1.0	30 3.0	50 5.0	160 16.0

\*G = Gauss  
mT = milliTesla.

# Solid State Sensors

## Surface Mount Digital Position Sensors

SS100 Series

### OPERATE AND RELEASE POINTS

SS111A

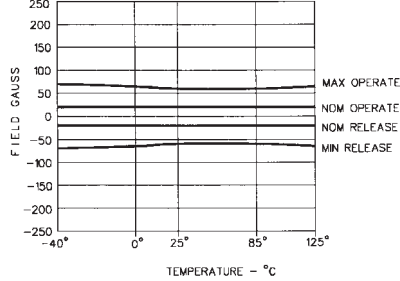

SS143A

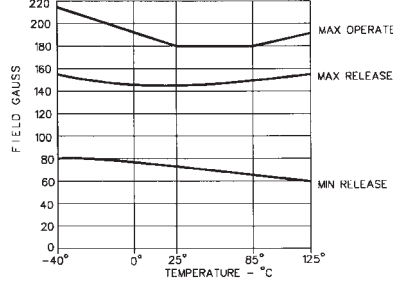

SS161A

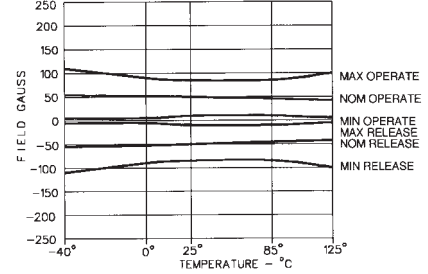

SS113A

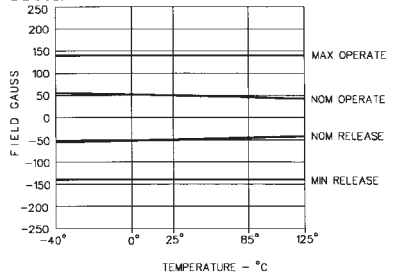

SS149A

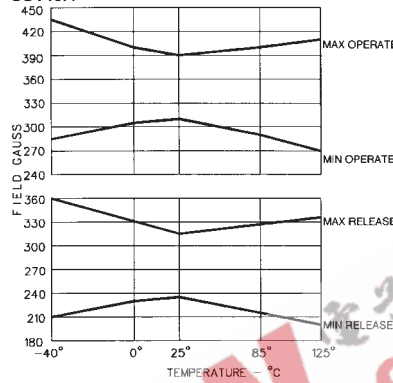

SS166A

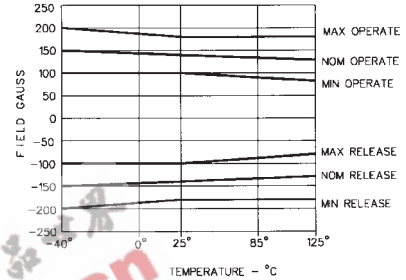

SS141A

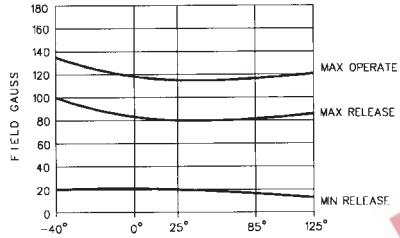

### MOUNTING DIMENSIONS (for reference only)

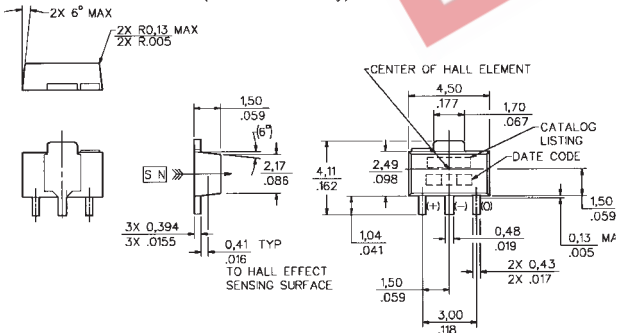

### REEL DIMENSIONS

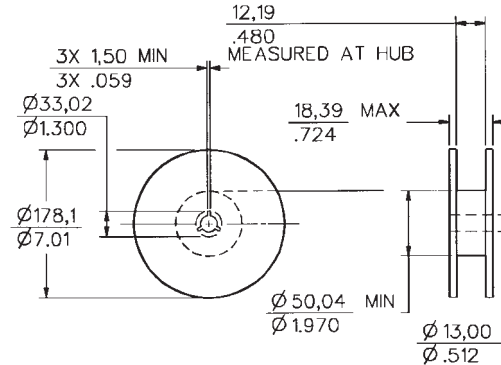

### TAPE DIMENSIONS

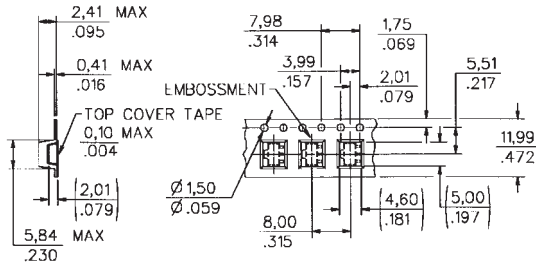

### NOTICE

Interruption of power to a latching device may cause the output to change state when power is restored. If a magnetic field of sufficient strength is present, the sensor output will be in the condition dictated by the magnetic field.

Digital