

FEATURES

- 25, 35, 45, 55 ns Read Access & Write Cycle Time
- Unlimited Read/Write Endurance
- Automatic Non-volatile STORE on Power Loss
- Non-Volatile STORE Under Hardware or Software Control
- Automatic RECALL to SRAM on Power Up
- Unlimited RECALL Cycles
- 1 Million STORE Cycles
- 100-Year Non-volatile Data Retention
- Single 5V ± 10% Power Supply
- Commercial, Industrial, Military Temperatures
- 28-pin 330-mil SOIC, 300-mil PDIP, and 600-mil PDIP Packages (RoHS-Compliant)
- 28-Pin CDIP and LCC Military Packages

DESCRIPTION

The Simtek STK12C68 is a 64Kb fast static RAM with a non-volatile Quantum Trap storage element included with each memory cell.

The SRAM provides the fast access & cycle times, ease of use and unlimited read & write endurance of a normal SRAM.

Data transfers automatically to the non-volatile storage cells when power loss is detected (the *STORE* operation). On power up, data is automatically restored to the SRAM (the *RECALL* operation). Both *STORE* and *RECALL* operations are also available under software control.

The Simtek nvSRAM is the first monolithic non-volatile memory to offer unlimited writes and reads. It is the highest performance, most reliable non-volatile memory available.

Block Diagram

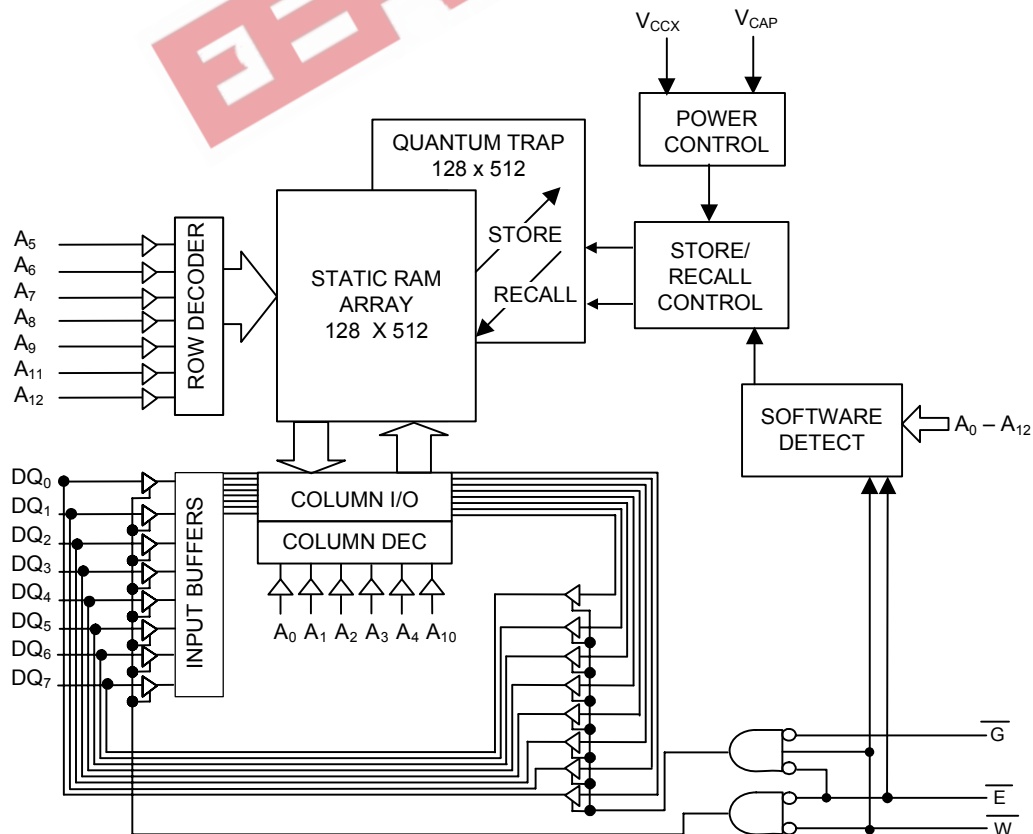

STK12C68 (SMD5962-94599)

Packages

| | | | |
|------|----|----|-------------|
| VCAP | 1 | 28 | VCCX |
| A12 | 2 | 27 | \bar{W} |
| A7 | 3 | 26 | \bar{HSB} |
| A6 | 4 | 25 | A8 |
| A5 | 5 | 24 | A9 |
| A4 | 6 | 23 | A11 |
| A3 | 7 | 22 | \bar{G} |
| A2 | 8 | 21 | A10 |
| A1 | 9 | 20 | \bar{E} |
| A0 | 10 | 19 | DQ7 |
| DQ0 | 11 | 18 | DQ6 |
| DQ1 | 12 | 17 | DQ5 |
| DQ2 | 13 | 16 | DQ4 |
| VSS | 14 | 15 | DQ3 |

28-pin SOIC
28-pin DIP

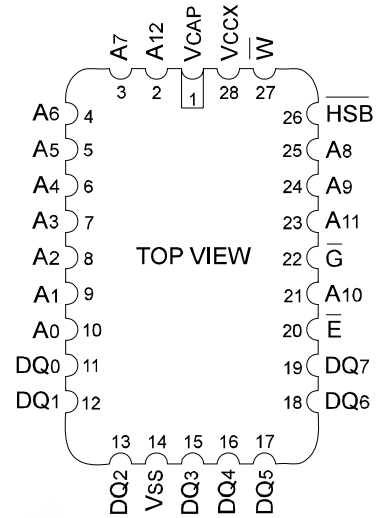

28-pin LCC

Pin Descriptions

| Pin Name | I/O | Description |
|----------------------------------|--------------|--|
| A ₁₂ -A ₀ | Input | Address: The 13 address inputs select one of 8,192 bytes in the nvSRAM array |
| DQ ₇ -DQ ₀ | I/O | Data: Bi-directional 8-bit data bus for accessing the nvSRAM |
| \bar{E} | Input | Chip Enable: The active low \bar{E} input selects the device |
| \bar{W} | Input | Write Enable: The active low \bar{W} enables data on the DQ pins to be written to the address location latched by the falling edge of \bar{E} |
| \bar{G} | Input | Output Enable: The active low \bar{G} input enables the data output buffers during read cycles. De-asserting \bar{G} high caused the DQ pins to tri-state. |
| V _{CCX} | Power Supply | Power: 5.0V, +10%, -10% |
| \bar{HSB} | I/O | Hardware Store Busy: When low this output indicates a Store is in progress. When pulled low external to the chip, it will initiate a nonvolatile STORE operation. A weak pull up resistor keeps this pin high if not connected. (Connection Optional). |
| V _{CAP} | Power Supply | AutoStore Capacitor: Supplies power to nvSRAM during power loss to store data from SRAM to nonvolatile storage elements. |
| V _{SS} | Power Supply | Ground |

STK12C68 (SMD5962-94599)

ABSOLUTE MAXIMUM RATINGS^a

| | |
|---|-----------------------------------|
| Voltage on Input Relative to Ground | -0.5V to 7.0V |
| Voltage on Input Relative to V _{SS} | -0.6V to (V _{CC} + 0.5V) |
| Voltage on DQ ₀₋₇ or HSB | -0.5V to (V _{CC} + 0.5V) |
| Temperature under Bias | -55°C to 125°C |
| Storage Temperature | -65°C to 150°C |
| Power Dissipation | 1W |
| DC Output Current (1 output at a time, 1s duration) | 15mA |

Note a: Stresses greater than those listed under "Absolute Maximum Ratings" may cause permanent damage to the device. This is a stress rating only, and functional operation of the device at conditions above those indicated in the operational sections of this specification is not implied. Exposure to absolute maximum rating conditions for extended periods may affect reliability.

DC CHARACTERISTICS

(V_{CC} = 5.0V ± 10%)^e

| SYMBOL | PARAMETER | COMMERCIAL | | INDUSTRIAL MILITARY | | UNITS | NOTES |
|-------------------------------|---|----------------------|----------------------|----------------------|----------------------|-------|--|
| | | MIN | MAX | MIN | MAX | | |
| I _{CC1} ^b | Average V _{CC} Current | | 85 | | 85 | mA | t _{AVAV} = 25ns t _{AVAV} = 35ns t _{AVAV} = 45ns t _{AVAV} = 55ns |
| | | | 75 | | 75 | mA | |
| | | | 65 | | 65 | mA | |
| | | | -- | | 55 | mA | |
| I _{CC2} ^c | Average V _{CC} Current during STORE | | 3 | | 3 | mA | All Inputs Don't Care, V _{CC} = max |
| I _{CC3} ^b | Average V _{CC} Current at t _{AVAV} = 200ns 5V, 25°C, Typical | | 10 | | 10 | mA | $\bar{W} \geq (V_{CC} - 0.2V)$ All Others Cycling, CMOS Levels |
| I _{CC4} ^c | Average V _{CAP} Current during AutoStore Cycle | | 2 | | 2 | mA | All Inputs Don't Care |
| I _{SB1} ^d | Average V _{CC} Current (Standby, Cycling TTL Input Levels) | | 27 | | 27 | mA | t _{AVAV} = 25ns, $\bar{E} \geq V_{IH}$ t _{AVAV} = 35ns, $\bar{E} \geq V_{IH}$ t _{AVAV} = 45ns, $\bar{E} \geq V_{IH}$ t _{AVAV} = 55ns, $\bar{E} \geq V_{IH}$ |
| | | | 24 | | 24 | mA | |
| | | | 20 | | 20 | mA | |
| | | | -- | | 19 | mA | |
| I _{SB2} ^d | V _{CC} Standby Current (Standby, Stable CMOS Input Levels) | | 1.5 | | 2.5 | mA | $\bar{E} \geq (V_{CC} - 0.2V)$ All Others V _{IN} ≤ 0.2V or ≥ (V _{CC} - 0.2V) |
| I _{ILK} | Input Leakage Current | | ±1 | | ±1 | µA | V _{CC} = max V _{IN} = V _{SS} to V _{CC} |
| I _{OLK} | Off-State Output Leakage Current | | ±5 | | ±5 | µA | V _{CC} = max V _{IN} = V _{SS} to V _{CC} , \bar{E} or $\bar{G} \geq V_{IH}$ |
| V _{IH} | Input Logic "1" Voltage | 2.2 | V _{CC} + .5 | 2.2 | V _{CC} + .5 | V | All Inputs |
| V _{IL} | Input Logic "0" Voltage | V _{SS} - .5 | 0.8 | V _{SS} - .5 | 0.8 | V | All Inputs |
| V _{OH} | Output Logic "1" Voltage | 2.4 | | 2.4 | | V | I _{OUT} = -4mA except HSB |
| V _{OL} | Output Logic "0" Voltage | | 0.4 | | 0.4 | V | I _{OUT} = 8mA except HSB |
| V _{BL} | Logic "0" Voltage on HSB Output | | 0.4 | | 0.4 | V | I _{OUT} = 3mA |
| T _A | Operating Temperature | 0 | 70 | -40/55 | 85/125 | °C | |

Note b: I_{CC1} and I_{CC3} are dependent on output loading and cycle rate. The specified values are obtained with outputs unloaded.

Note c: I_{CC2} and I_{CC4} are the average currents required for the duration of the respective STORE cycles (t_{STORE}).

Note d: $\bar{E} \geq V_{IH}$ will not produce standby current levels until any nonvolatile cycle in progress has timed out.

Note e: V_{CC} reference levels throughout this datasheet refer to V_{CCX} if that is where the power supply connection is made, or V_{CAP} if V_{CCX} is connected to ground.

AC TEST CONDITIONS

| | |
|--|--------------|
| Input Pulse Levels | 0V to 3V |
| Input Rise and Fall Times | ≤ 5ns |
| Input and Output Timing Reference Levels | 1.5V |
| Output Load | See Figure 1 |

CAPACITANCE^f (T_A = 25°C, f = 1.0MHz)

| SYMBOL | PARAMETER | MAX | UNITS | CONDITIONS |
|------------------|--------------------|-----|-------|--------------|
| C _{IN} | Input Capacitance | 8 | pF | ΔV = 0 to 3V |
| C _{OUT} | Output Capacitance | 7 | pF | ΔV = 0 to 3V |

Note f: These parameters are guaranteed but not tested.

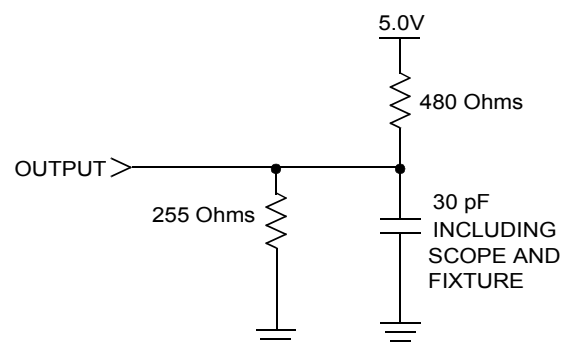

Figure 1. AC Output Loading

STK12C68 (SMD5962-94599)

SRAM READ CYCLES #1 & #2

($V_{CC} = 5.0V \pm 10\%$)^e

| NO. | SYMBOLS | | PARAMETER | STK12C68-25 | | STK12C68-35 | | STK12C68-45 | | STK12C68-55 | | UNITS |
|-----|----------------|-----------|-----------------------------------|-------------|-----|-------------|-----|-------------|-----|-------------|-----|-------|
| | #1, #2 | Alt. | | MIN | MAX | MIN | MAX | MIN | MAX | MIN | MAX | |
| 1 | t_{ELQV} | t_{ACS} | Chip Enable Access Time | | 25 | | 35 | | 45 | | 55 | ns |
| 2 | t_{AVAV}^g | t_{RC} | Read Cycle Time | 25 | | 35 | | 45 | | 55 | | ns |
| 3 | t_{AVQV}^h | t_{AA} | Address Access Time | | 25 | | 35 | | 45 | | 55 | ns |
| 4 | t_{GLQV} | t_{OE} | Output Enable to Data Valid | | 10 | | 15 | | 20 | | 35 | ns |
| 5 | t_{AXQX}^h | t_{OH} | Output Hold after Address Change | 5 | | 5 | | 5 | | 5 | | ns |
| 6 | t_{ELQX} | t_{LZ} | Chip Enable to Output Active | 5 | | 5 | | 5 | | 5 | | ns |
| 7 | t_{EHQZ}^j | t_{HZ} | Chip Disable to Output Inactive | | 10 | | 10 | | 12 | | 12 | ns |
| 8 | t_{GLQX} | t_{OLZ} | Output Enable to Output Active | 0 | | 0 | | 0 | | 0 | | ns |
| 9 | t_{GHQZ}^i | t_{OHZ} | Output Disable to Output Inactive | | 10 | | 10 | | 12 | | 12 | ns |
| 10 | t_{ELICCH}^f | t_{PA} | Chip Enable to Power Active | 0 | | 0 | | 0 | | 0 | | ns |
| 11 | t_{EHICCL}^f | t_{PS} | Chip Disable to Power Standby | | 25 | | 35 | | 45 | | 55 | ns |

Note g: \overline{W} and \overline{HSB} must be high during SRAM READ cycles.

Note h: Device is continuously selected with \overline{E} and \overline{G} both low.

Note i: Measured $\pm 200mV$ from steady state output voltage.

SRAM READ CYCLE #1: Address Controlled^{g, h}

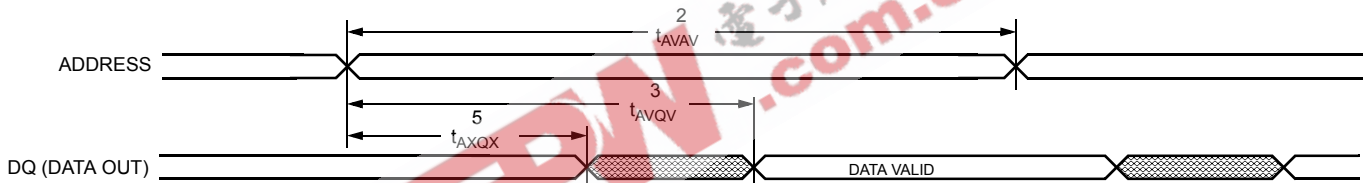

SRAM READ CYCLE #2: \overline{E} Controlled^g

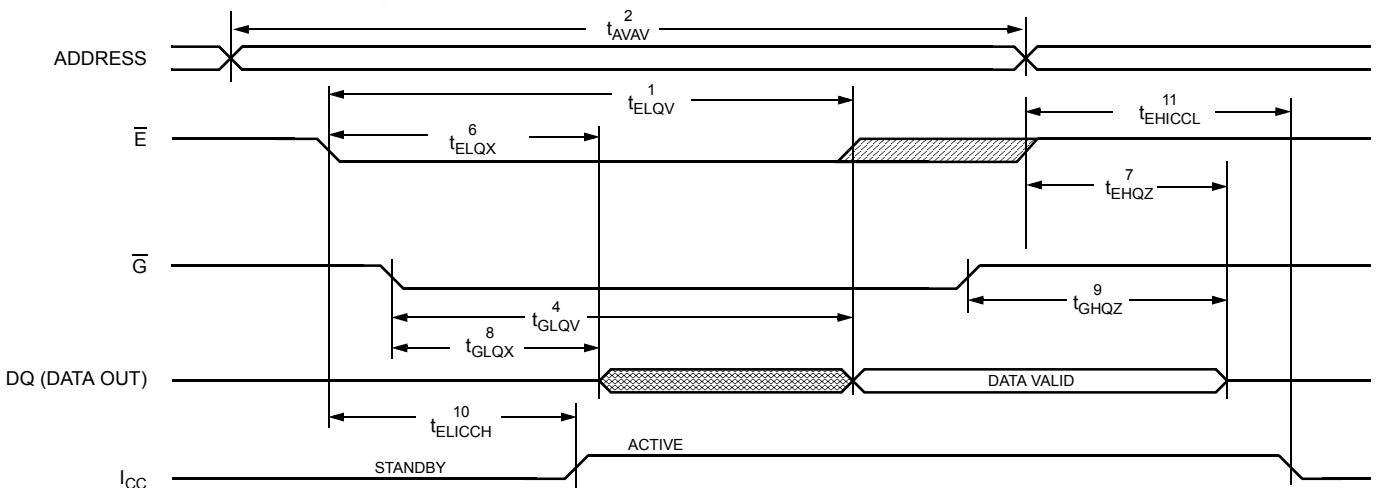

SRAM WRITE CYCLES #1 & #2

($V_{CC} = 5.0V \pm 10\%$)^e

| NO. | SYMBOLS | | | PARAMETER | STK12C68-25 | | STK12C68-35 | | STK12C68-45 | | STK12C68-55 | | UNITS |
|-----|------------------|------------|----------|----------------------------------|-------------|-----|-------------|-----|-------------|-----|-------------|-----|-------|
| | #1 | #2 | Alt. | | MIN | MAX | MIN | MAX | MIN | MAX | MIN | MAX | |
| 12 | t_{AVAV} | t_{AVAV} | t_{WC} | Write Cycle Time | 25 | | 35 | | 45 | | 55 | | ns |
| 13 | t_{WLWH} | t_{WLEH} | t_{WP} | Write Pulse Width | 20 | | 25 | | 30 | | 45 | | ns |
| 14 | t_{ELWH} | t_{ELEH} | t_{CW} | Chip Enable to End of Write | 20 | | 25 | | 30 | | 45 | | ns |
| 15 | t_{DVWH} | t_{DVEH} | t_{DW} | Data Set-up to End of Write | 10 | | 12 | | 15 | | 25 | | ns |
| 16 | t_{WHDX} | t_{EHDX} | t_{DH} | Data Hold after End of Write | 0 | | 0 | | 0 | | 0 | | ns |
| 17 | t_{AVWH} | t_{AVEH} | t_{AW} | Address Set-up to End of Write | 20 | | 25 | | 30 | | 45 | | ns |
| 18 | t_{AVWL} | t_{AVEL} | t_{AS} | Address Set-up to Start of Write | 0 | | 0 | | 0 | | 0 | | ns |
| 19 | t_{WHAX} | t_{EHAX} | t_{WR} | Address Hold after End of Write | 0 | | 0 | | 0 | | 0 | | ns |
| 20 | $t_{WLQZ}^{i,j}$ | | t_{WZ} | Write Enable to Output Disable | | 10 | | 13 | | 14 | | 15 | ns |
| 21 | t_{WHQX} | | t_{OW} | Output Active after End of Write | 5 | | 5 | | 5 | | 5 | | ns |

Note j: If \bar{W} is low when \bar{E} goes low, the outputs remain in the high-impedance state.

Note k: \bar{E} or \bar{W} must be $\geq V_{IH}$ during address transitions.

Note l: HSB must be high during SRAM WRITE cycles.

SRAM WRITE CYCLE #1: \bar{W} Controlled^{k, l}

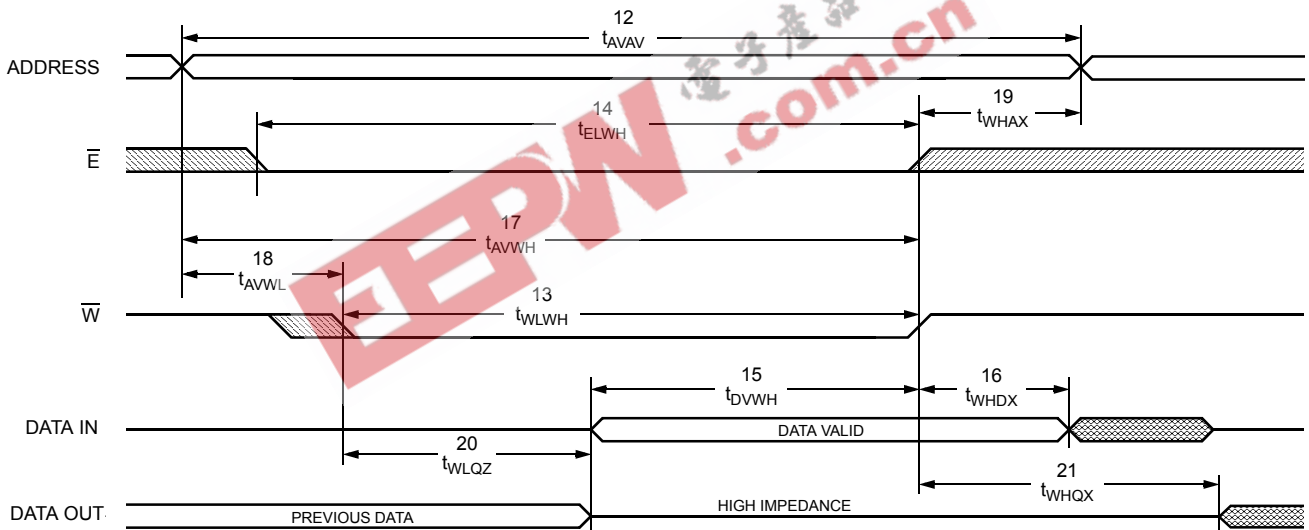

SRAM WRITE CYCLE #2: \bar{E} Controlled^{k, l}

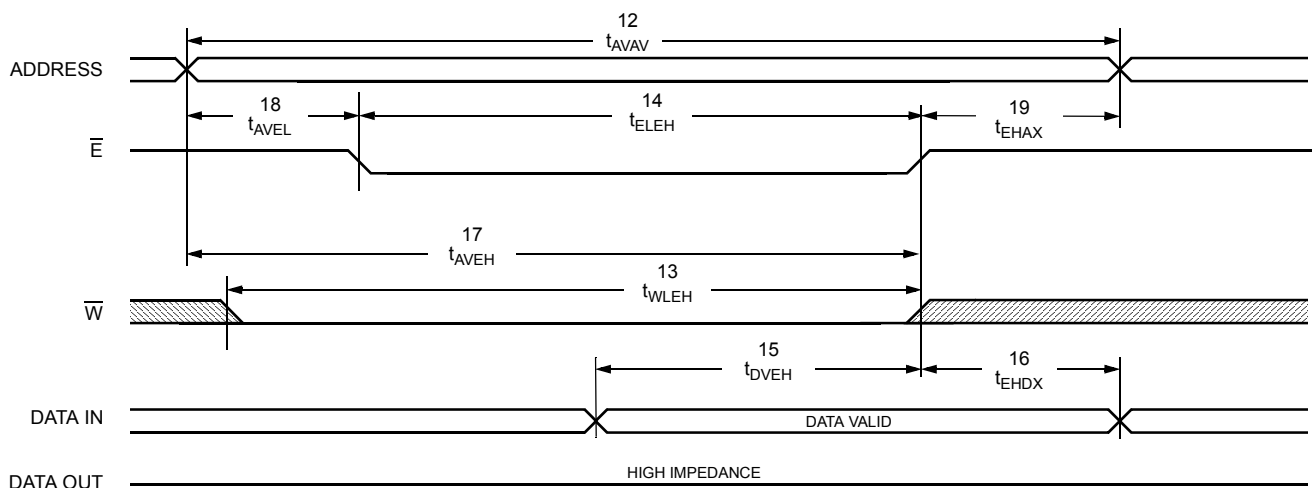

STK12C68 (SMD5962-94599)

HARDWARE MODE SELECTION

| \bar{E} | \bar{W} | \overline{HSB} | A ₁₂ - A ₀ (hex) | MODE | I/O | POWER | NOTES |
|-----------|-----------|------------------|--|---|--|--|-------|
| H | X | H | X | Not Selected | Output High Z | Standby | |
| L | H | H | X | Read SRAM | Output Data | Active | o |
| L | L | H | X | Write SRAM | Input Data | Active | |
| X | X | L | X | Nonvolatile STORE | Output High Z | I _{CC2} | m |
| L | H | H | 0000 1555 0AAA 1FFF 10F0 0F0F | Read SRAM Read SRAM Read SRAM Read SRAM Read SRAM Nonvolatile STORE | Output Data Output Data Output Data Output Data Output Data Output High Z | Active I _{CC2} | n, o |
| L | H | H | 0000 1555 0AAA 1FFF 10F0 0F0E | Read SRAM Read SRAM Read SRAM Read SRAM Read SRAM Nonvolatile RECALL | Output Data Output Data Output Data Output Data Output Data Output High Z | Active | n, o |

Note m: \overline{HSB} STORE operation occurs only if an SRAM WRITE has been done since the last nonvolatile cycle. After the STORE (if any) completes, the part will go into standby mode, inhibiting all operations until \overline{HSB} rises.

Note n: The six consecutive addresses must be in the order listed. \bar{W} must be high during all six consecutive cycles to enable a nonvolatile cycle.

Note o: I/O state assumes $\bar{G} \leq V_{IL}$. Activation of nonvolatile cycles does not depend on state of \bar{G} .

HARDWARE STORE CYCLE

(V_{CC} = 5.0V ± 10%)^e

| NO. | SYMBOLS | | PARAMETER | STK12C68 | | UNITS | NOTES |
|-----|----------------------|-------------------|-------------------------------------|----------|-----|-------|-------|
| | Standard | Alternate | | MIN | MAX | | |
| 22 | t _{STORE} | t _{HLHZ} | STORE Cycle Duration | | 10 | ms | i, p |
| 23 | t _{DELAY} | t _{HLQZ} | Time Allowed to Complete SRAM Cycle | 1 | | μs | i, q |
| 24 | t _{RECOVER} | t _{HHQX} | Hardware STORE High to Inhibit Off | | 700 | ns | p, r |
| 25 | t _{HLHX} | | Hardware STORE Pulse Width | 15 | | ns | |
| 26 | t _{HLBL} | | Hardware STORE Low to Store Busy | | 300 | ns | |

Note p: \bar{E} and \bar{G} low for output behavior.

Note q: \bar{E} and \bar{G} low and \bar{W} high for output behavior.

Note r: t_{RECOVER} is only applicable after t_{STORE} is complete.

HARDWARE STORE CYCLE

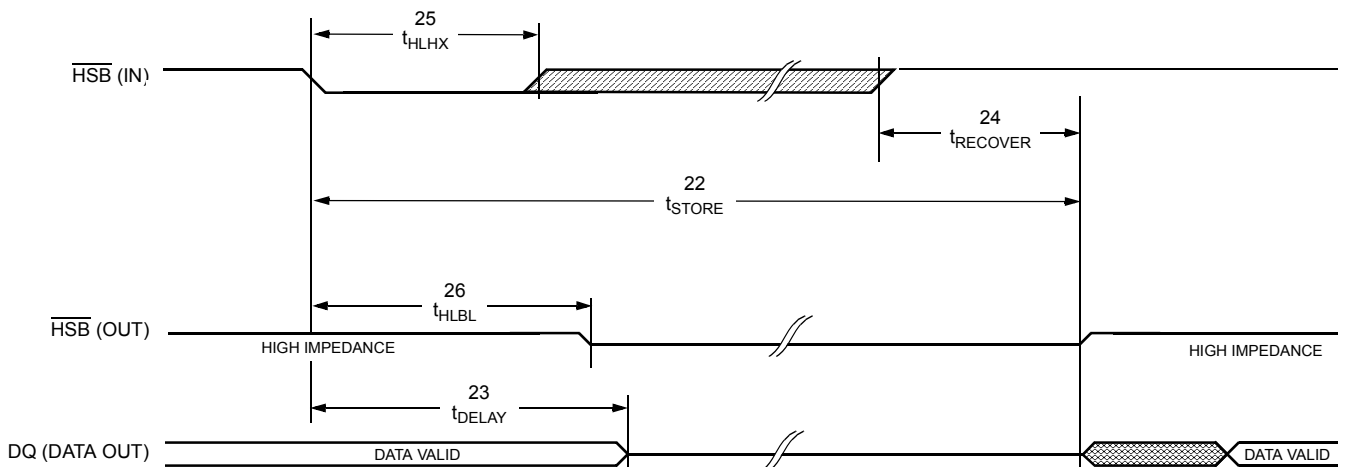

AutoStore / POWER-UP RECALL

($V_{CC} = 5.0V \pm 10\%$)^e

| NO. | SYMBOLS | | PARAMETER | STK12C68 | | UNITS | NOTES |
|-----|---------------|------------|--|----------|-----|---------|---------|
| | Standard | Alternate | | MIN | MAX | | |
| 27 | $t_{RESTORE}$ | | Power-up <i>RECALL</i> Duration | | 550 | μs | s |
| 28 | t_{STORE} | t_{HLHZ} | <i>STORE</i> Cycle Duration | | 10 | ms | p, q, t |
| 29 | t_{VSBL} | | Low Voltage Trigger (V_{SWITCH}) to \overline{HSB} Low | | 300 | ns | l |
| 30 | t_{DELAY} | t_{BLQZ} | Time Allowed to Complete SRAM Cycle | 1 | | μs | p |
| 31 | V_{SWITCH} | | Low Voltage Trigger Level | 4.0 | 4.5 | V | |
| 32 | V_{RESET} | | Low Voltage Reset Level | | 3.9 | V | |

Note s: $t_{RESTORE}$ starts from the time V_{CC} rises above V_{SWITCH} .

Note t: \overline{HSB} is asserted low for $1\mu s$ when V_{CAP} drops through V_{SWITCH} . If an SRAM WRITE has not taken place since the last nonvolatile cycle, \overline{HSB} will be released and no *STORE* will take place.

AutoStore / POWER-UP RECALL

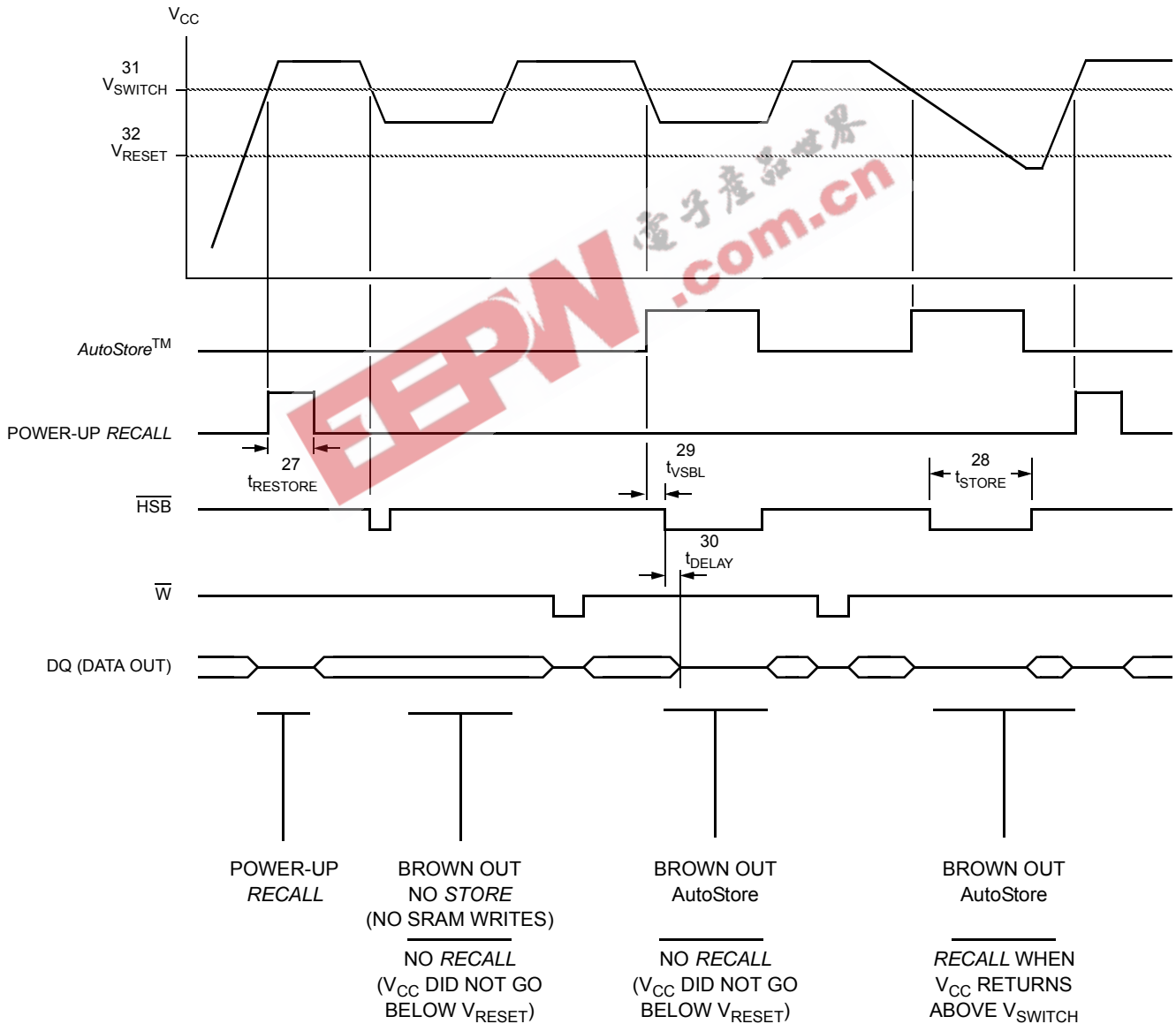

STK12C68 (SMD5962-94599)

SOFTWARE-CONTROLLED STORE/RECALL CYCLE^v

($V_{CC} = 5.0V \pm 10\%$)^e

| NO. | SYMBOLS | | PARAMETER | STK12C68-25 | | STK12C68-35 | | STK12C68-45 | | STK12C68-55 | | UNITS | NOTES |
|-----|--------------|-----------|------------------------------------|-------------|-----|-------------|-----|-------------|-----|-------------|-----|---------|-------|
| | Standard | Alternate | | MIN | MAX | MIN | MAX | MIN | MAX | MIN | MAX | | |
| 33 | t_{AVAV} | t_{RC} | STORE/RECALL Initiation Cycle Time | 25 | | 35 | | 45 | | 55 | | ns | p |
| 34 | t_{AVEL} | t_{AS} | Address Set-up Time | 0 | | 0 | | 0 | | 0 | | ns | u |
| 35 | t_{ELEH} | t_{CW} | Clock Pulse Width | 20 | | 25 | | 30 | | 30 | | ns | u |
| 36 | t_{ELAX} | | Address Hold Time | 20 | | 20 | | 20 | | 20 | | ns | u |
| 37 | t_{RECALL} | | RECALL Duration | | 20 | | 20 | | 20 | | 20 | μs | |

Note u: The software sequence is clocked with \bar{E} controlled READs.

Note v: The six consecutive addresses must be in the order listed in the Hardware Mode Selection Table: (0000, 1555, 0AAA, 1FFF, 10F0, 0F0F) for a STORE cycle or (0000, 1555, 0AAA, 1FFF, 10F0, 0F0E) for a RECALL cycle. W must be high during all six consecutive cycles.

SOFTWARE STORE/RECALL CYCLE: \bar{E} Controlled^v

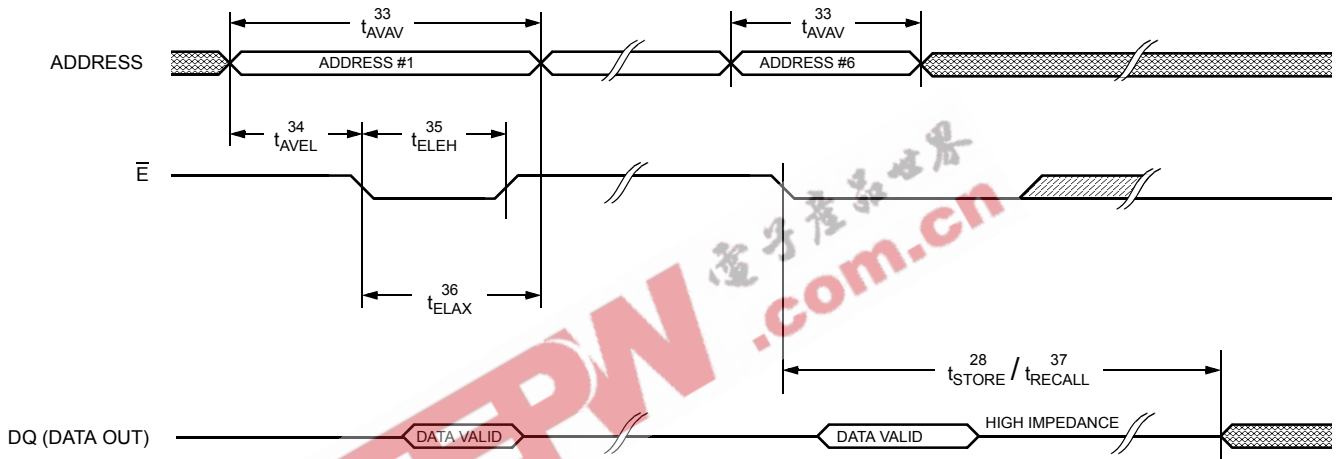

DEVICE OPERATION

The STK12C68 has two separate modes of operation: SRAM mode and nonvolatile mode. In SRAM mode, the memory operates as a standard fast static RAM. In nonvolatile mode, data is transferred from SRAM to Nonvolatile Elements (the *STORE* operation) or from Nonvolatile Elements to SRAM (the *RECALL* operation). In this mode SRAM functions are disabled.

NOISE CONSIDERATIONS

The STK12C68 is a high-speed memory and so must have a high-frequency bypass capacitor of approximately 0.1 μ F connected between V_{CAP} and V_{SS} , using leads and traces that are as short as possible. As with all high-speed CMOS ICs, normal careful routing of power, ground and signals will help prevent noise problems.

SRAM READ

The STK12C68 performs a READ cycle whenever \bar{E} and \bar{G} are low and \bar{W} and HSB are high. The address specified on pins A_{0-12} determines which of the 8,192 data bytes will be accessed. When the READ is initiated by an address transition, the outputs will be valid after a delay of t_{AVQV} (READ cycle #1). If the READ is initiated by \bar{E} or \bar{G} , the outputs will be valid at t_{ELQV} or at t_{GLQV} , whichever is later (READ cycle #2). The data outputs will repeatedly respond to address changes within the t_{AVQV} access time without the need for transitions on any control input pins, and will remain valid until another address change or until \bar{E} or \bar{G} is brought high, or \bar{W} or HSB is brought low.

SRAM WRITE

A WRITE cycle is performed whenever \bar{E} and \bar{W} are low and HSB is high. The address inputs must be stable prior to entering the WRITE cycle and must remain stable until either \bar{E} or \bar{W} goes high at the end of the cycle. The data on the common I/O pins DQ_{0-7} will be written into the memory if it is valid t_{DVWH} before the end of a \bar{W} controlled WRITE or t_{DVEH} before the end of an \bar{E} controlled WRITE.

It is recommended that \bar{G} be kept high during the entire WRITE cycle to avoid data bus contention on common I/O lines. If \bar{G} is left low, internal circuitry will turn off the output buffers t_{WLQZ} after \bar{W} goes low.

POWER-UP RECALL

During power up, or after any low-power condition ($V_{CAP} < V_{RESET}$), an internal *RECALL* request will be latched. When V_{CAP} once again exceeds the sense voltage of V_{SWITCH} , a *RECALL* cycle will automatically be initiated and will take $t_{RESTORE}$ to complete.

If the STK12C68 is in a WRITE state at the end of power-up *RECALL*, the SRAM data will be corrupted. To help avoid this situation, a 10K Ohm resistor should be connected either between \bar{W} and system V_{CC} or between \bar{E} and system V_{CC} .

SOFTWARE NONVOLATILE STORE

The STK12C68 software *STORE* cycle is initiated by executing sequential \bar{E} controlled READ cycles from six specific address locations. During the *STORE* cycle an erase of the previous nonvolatile data is first performed, followed by a program of the nonvolatile elements. The program operation copies the SRAM data into nonvolatile memory. Once a *STORE* cycle is initiated, further input and output are disabled until the cycle is completed.

Because a sequence of READs from specific addresses is used for *STORE* initiation, it is important that no other READ or WRITE accesses intervene in the sequence, or the sequence will be aborted and no *STORE* or *RECALL* will take place.

To initiate the software *STORE* cycle, the following READ sequence must be performed:

- | | | |
|-----------------|------------|-----------------------------|
| 1. Read address | 0000 (hex) | Valid READ |
| 2. Read address | 1555 (hex) | Valid READ |
| 3. Read address | 0AAA (hex) | Valid READ |
| 4. Read address | 1FFF (hex) | Valid READ |
| 5. Read address | 10F0 (hex) | Valid READ |
| 6. Read address | 0F0F (hex) | Initiate <i>STORE</i> cycle |

The software sequence must be clocked with \bar{E} controlled READs.

Once the sixth address in the sequence has been entered, the *STORE* cycle will commence and the chip will be disabled. It is important that READ cycles and not WRITE cycles be used in the sequence, although it is not necessary that \bar{G} be low for the sequence to be valid. After the t_{STORE} cycle time has been fulfilled, the SRAM will again be activated for READ and WRITE operation.

STK12C68 (SMD5962-94599)

SOFTWARE NONVOLATILE RECALL

A software *RECALL* cycle is initiated with a sequence of READ operations in a manner similar to the software *STORE* initiation. To initiate the *RECALL* cycle, the following sequence of \bar{E} controlled READ operations must be performed:

- | | | |
|-----------------|------------|------------------------------|
| 1. Read address | 0000 (hex) | Valid READ |
| 2. Read address | 1555 (hex) | Valid READ |
| 3. Read address | 0AAA (hex) | Valid READ |
| 4. Read address | 1FFF (hex) | Valid READ |
| 5. Read address | 10F0 (hex) | Valid READ |
| 6. Read address | 0F0E (hex) | Initiate <i>RECALL</i> cycle |

Internally, *RECALL* is a two-step procedure. First, the SRAM data is cleared, and second, the nonvolatile information is transferred into the SRAM cells. After the t_{RECALL} cycle time the SRAM will once again be ready for READ and WRITE operations. The *RECALL* operation in no way alters the data in the Nonvolatile Elements. The nonvolatile data can be recalled an unlimited number of times.

AutoStore OPERATION

The STK12C68 can be powered in one of three modes.

During normal AutoStore operation, the STK12C68 will draw current from V_{CCX} to charge a capacitor connected to the V_{CAP} pin. This stored charge will be used by the chip to perform a single *STORE* operation. After power up, when the voltage on the V_{CAP} pin drops below V_{SWITCH} , the part will automatically disconnect the V_{CAP} pin from V_{CCX} and initiate a *STORE* operation.

Figure 2 shows the proper connection of capacitors for automatic store operation. A charge storage

capacitor having a capacity of between $68\mu\text{F}$ and $220\mu\text{F}$ ($\pm 20\%$) rated at 6V should be provided.

In system power mode (Figure 3), both V_{CCX} and V_{CAP} are connected to the + 5V power supply without the $68\mu\text{F}$ capacitor. In this mode the AutoStore function of the STK12C68 will operate on the stored system charge as power goes down. The user must, however, guarantee that V_{CCX} does not drop below 3.6V during the 10ms *STORE* cycle.

If an automatic *STORE* on power loss is not required, then V_{CCX} can be tied to ground and + 5V applied to V_{CAP} (Figure 4). This is the AutoStore Inhibit mode, in which the AutoStore function is disabled. If the STK12C68 is operated in this configuration, references to V_{CCX} should be changed to V_{CAP} throughout this data sheet. In this mode, *STORE* operations may be triggered through software control or the $\overline{\text{HSB}}$ pin. It is not permissible to change between these three options "on the fly."

In order to prevent unneeded *STORE* operations, automatic *STORES* as well as those initiated by externally driving $\overline{\text{HSB}}$ low will be ignored unless at least one WRITE operation has taken place since the most recent *STORE* or *RECALL* cycle. Software initiated *STORE* cycles are performed regardless of whether a WRITE operation has taken place. An optional pull-up resistor is shown connected to $\overline{\text{HSB}}$. This can be used to signal the system that the AutoStore cycle is in progress.

If the power supply drops faster than $20 \mu\text{s}/\text{volt}$ before V_{CCX} reaches V_{SWITCH} , then a 2.2 ohm resistor should be inserted between V_{CCX} and the system supply to avoid momentary excess of current between V_{CCX} and V_{CAP} .

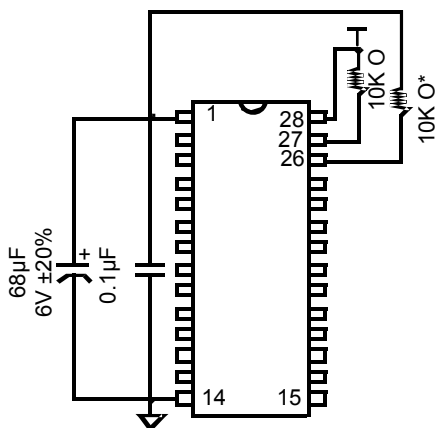

Figure 2. AutoStore Mode

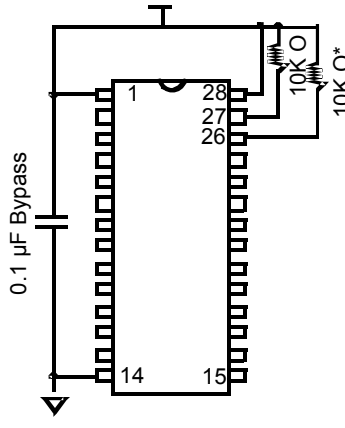

Figure 3. System Power Mode

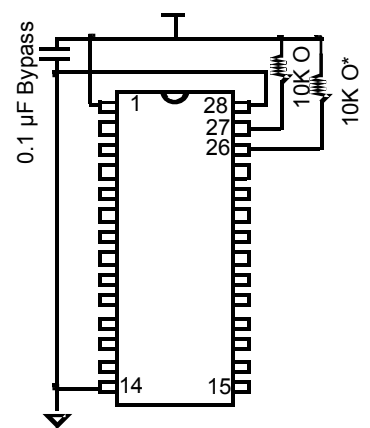

Figure 4. AutoStore Inhibit Mode

HSB OPERATION

The STK12C68 provides the $\overline{\text{HSB}}$ pin for controlling and acknowledging the *STORE* operations. The $\overline{\text{HSB}}$ pin is used to request a hardware *STORE* cycle. When the $\overline{\text{HSB}}$ pin is driven low, the STK12C68 will conditionally initiate a *STORE* operation after t_{DELAY} ; an actual *STORE* cycle will only begin if a *WRITE* to the SRAM took place since the last *STORE* or *RECALL* cycle. The $\overline{\text{HSB}}$ pin acts as an open drain driver that is internally driven low to indicate a busy condition while the *STORE* (initiated by any means) is in progress.

SRAM READ and WRITE operations that are in progress when $\overline{\text{HSB}}$ is driven low by any means are given time to complete before the *STORE* operation is initiated. After $\overline{\text{HSB}}$ goes low, the STK12C68 will continue SRAM operations for t_{DELAY} . During t_{DELAY} , multiple SRAM READ operations may take place. If a *WRITE* is in progress when $\overline{\text{HSB}}$ is pulled low it will be allowed a time, t_{DELAY} , to complete. However, any SRAM WRITE cycles requested after $\overline{\text{HSB}}$ goes low will be inhibited until $\overline{\text{HSB}}$ returns high.

The $\overline{\text{HSB}}$ pin can be used to synchronize multiple STK12C68s while using a single larger capacitor. To operate in this mode the $\overline{\text{HSB}}$ pin should be connected together to the $\overline{\text{HSB}}$ pins from the other STK12C68s. An external pull-up resistor to +5V is required since $\overline{\text{HSB}}$ acts as an open drain pull down. The V_{CAP} pins from the other STK12C68 parts can be tied together and share a single capacitor. The capacitor size must be scaled by the number of devices connected to it. When any one of the STK12C68s detects a power loss and asserts $\overline{\text{HSB}}$, the common $\overline{\text{HSB}}$ pin will cause all parts to request a *STORE* cycle (a *STORE* will take place in those STK12C68s that have been written since the last nonvolatile cycle).

During any *STORE* operation, regardless of how it was initiated, the STK12C68 will continue to drive the $\overline{\text{HSB}}$ pin low, releasing it only when the *STORE* is complete. Upon completion of the *STORE* operation the STK12C68 will remain disabled until the $\overline{\text{HSB}}$ pin returns high.

If $\overline{\text{HSB}}$ is not used, it should be left unconnected.

PREVENTING STORES

The *STORE* function can be disabled on the fly by holding $\overline{\text{HSB}}$ high with a driver capable of sourcing 30mA at a V_{OH} of at least 2.2V, as it will have to overpower the internal pull-down device that drives $\overline{\text{HSB}}$ low for 20 μ s at the onset of a *STORE*. When the STK12C68 is connected for AutoStore operation (system V_{CC} connected to V_{CCX} and a 68 μ F capacitor on V_{CAP}) and V_{CC} crosses V_{SWITCH} on the way down, the STK12C68 will attempt to pull $\overline{\text{HSB}}$ low; if $\overline{\text{HSB}}$ doesn't actually get below V_{IL} , the part will stop trying to pull $\overline{\text{HSB}}$ low and abort the *STORE* attempt.

HARDWARE PROTECT

The STK12C68 offers hardware protection against inadvertent *STORE* operation and SRAM WRITES during low-voltage conditions. When $V_{\text{CAP}} < V_{\text{SWITCH}}$, all externally initiated *STORE* operations and SRAM WRITES are inhibited.

AutoStore can be completely disabled by tying V_{CCX} to ground and applying +5V to V_{CAP} . This is the AutoStore inhibit mode; in this mode, *STORE*s are only initiated by explicit request using either the software sequence or the $\overline{\text{HSB}}$ pin.

LOW AVERAGE ACTIVE POWER

The STK12C68 draws significantly less current when it is cycled at times longer than 50ns. Figure 5 shows the relationship between I_{CC} and READ cycle time. Worst-case current consumption is shown for both CMOS and TTL input levels (commercial temperature range, $V_{\text{CC}} = 5.5\text{V}$, 100% duty cycle on chip enable). Figure 6 shows the same relationship for WRITE cycles. If the chip enable duty cycle is less than 100%, only standby current is drawn when the chip is disabled. The overall average current drawn by the STK12C68 depends on the following items: 1) CMOS vs. TTL input levels; 2) the duty cycle of chip enable; 3) the overall cycle rate for accesses; 4) the ratio of READs to WRITES; 5) the operating temperature; 6) the V_{CC} level; and 7) I/O loading.

STK12C68 (SMD5962-94599)

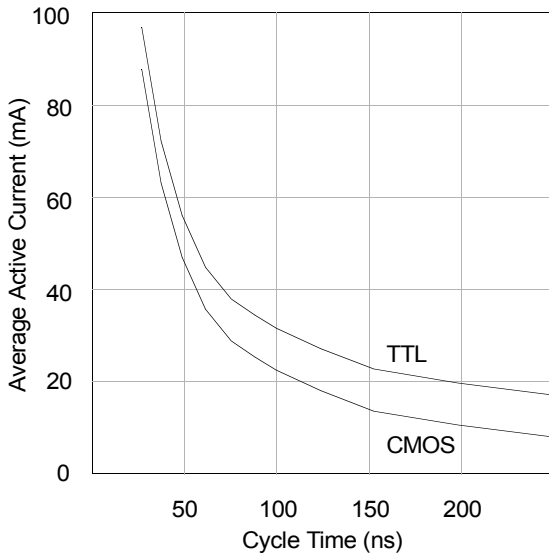

Figure 5: I_{cc} (max) Reads

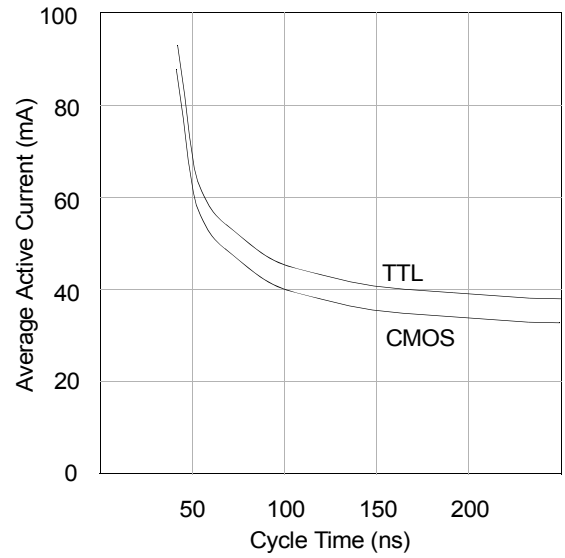
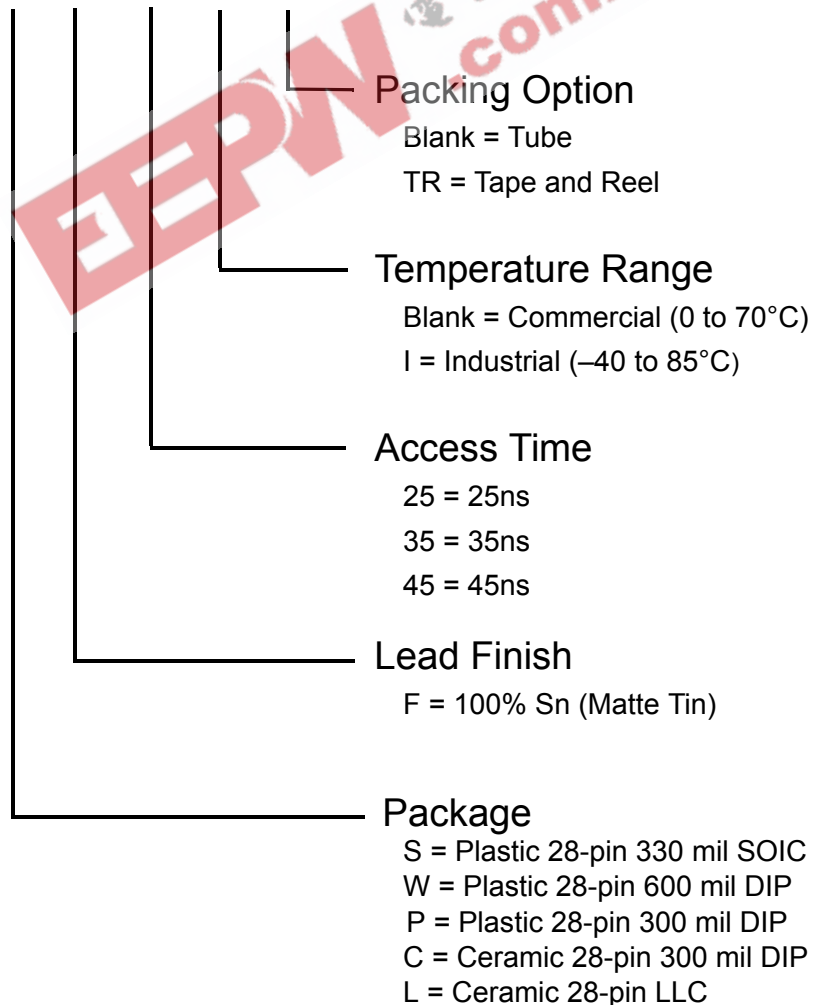

Figure 6: I_{cc} (max) Writes

Commercial and Industrial Ordering Information

STK12C68 - S F 45 I TR



Military Ordering Information

STK12C68 - 5 C 35 M

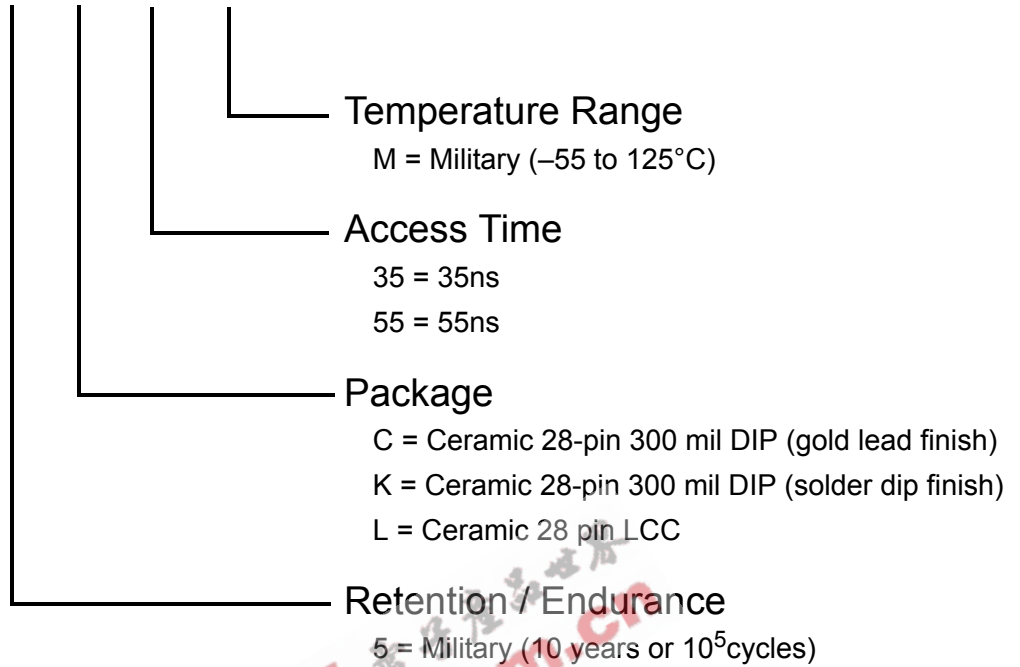

5962 - 94599 01 MX X

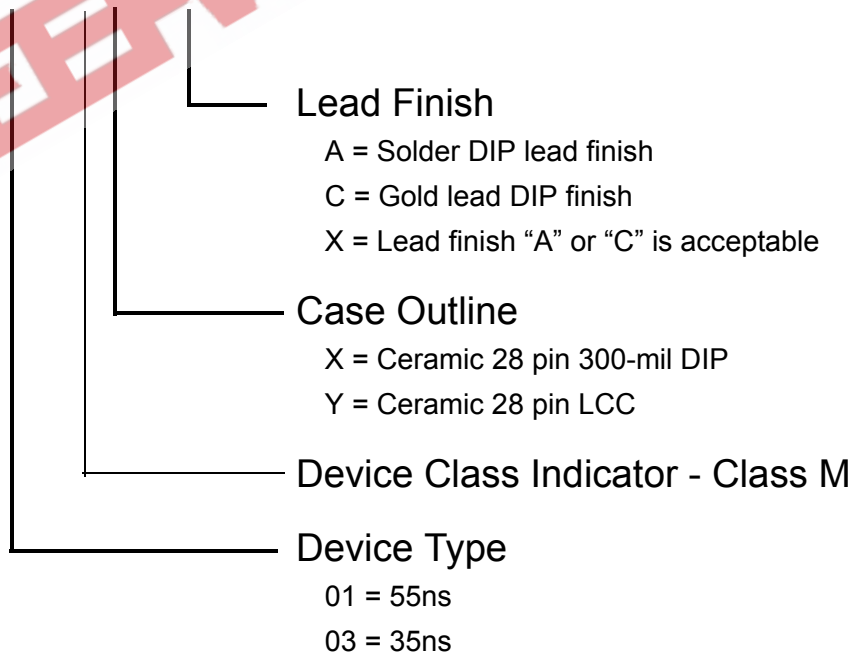

STK12C68 (SMD5962-94599)

Ordering Information

| Part Number | Description | Temperature |
|--------------------|-------------------------------------|-------------|
| STK12C68-C35 | 5V 8Kx8 AutoStore nvSRAM CDIP28-300 | Commercial |
| STK12C68-C45 | 5V 8Kx8 AutoStore nvSRAM CDIP28-300 | Commercial |
| STK12C68-L35 | 5V 8Kx8 AutoStore nvSRAM LCC28 | Commercial |
| STK12C68-L45 | 5V 8Kx8 AutoStore nvSRAM LCC28 | Commercial |
| STK12C68-PF25 | 5V 8Kx8 AutoStore nvSRAM PDIP28-600 | Commercial |
| STK12C68-PF45 | 5V 8Kx8 AutoStore nvSRAM PDIP28-600 | Commercial |
| STK12C68-SF25 | 5V 8Kx8 AutoStore nvSRAM SOP28-330 | Commercial |
| STK12C68-SF25TR | 5V 8Kx8 AutoStore nvSRAM SOP28-330 | Commercial |
| STK12C68-SF45 | 5V 8Kx8 AutoStore nvSRAM SOP28-330 | Commercial |
| STK12C68-SF45TR | 5V 8Kx8 AutoStore nvSRAM SOP28-330 | Commercial |
| STK12C68-WF25 | 5V 8Kx8 AutoStore nvSRAM PDIP28-600 | Commercial |
| STK12C68-WF45 | 5V 8Kx8 AutoStore nvSRAM PDIP28-600 | Commercial |
| STK12C68-C35I | 5V 8Kx8 AutoStore nvSRAM CDIP28-300 | Industrial |
| STK12C68-C45I | 5V 8Kx8 AutoStore nvSRAM CDIP28-300 | Industrial |
| STK12C68-L35I | 5V 8Kx8 AutoStore nvSRAM LCC28 | Industrial |
| STK12C68-L45I | 5V 8Kx8 AutoStore nvSRAM LCC28 | Industrial |
| STK12C68-PF25I | 5V 8Kx8 AutoStore nvSRAM PDIP28-600 | Industrial |
| STK12C68-PF45I | 5V 8Kx8 AutoStore nvSRAM PDIP28-600 | Industrial |
| STK12C68-SF25I | 5V 8Kx8 AutoStore nvSRAM SOP28-330 | Industrial |
| STK12C68-SF25ITR | 5V 8Kx8 AutoStore nvSRAM SOP28-330 | Industrial |
| STK12C68-SF45I | 5V 8Kx8 AutoStore nvSRAM SOP28-330 | Industrial |
| STK12C68-SF45ITR | 5V 8Kx8 AutoStore nvSRAM SOP28-330 | Industrial |
| STK12C68-WF25I | 5V 8Kx8 AutoStore nvSRAM PDIP28-600 | Industrial |
| STK12C68-WF45I | 5V 8Kx8 AutoStore nvSRAM PDIP28-600 | Industrial |
| SMD5962-9459901MXA | 5V 8Kx8 AutoStore nvSRAM CDIP28-300 | Military |
| SMD5962-9459901MXC | 5V 8Kx8 AutoStore nvSRAM CDIP28-300 | Military |
| SMD5962-9459901MXX | 5V 8Kx8 AutoStore nvSRAM CDIP28-300 | Military |
| SMD5962-9459901MYA | 5V 8Kx8 AutoStore nvSRAM LCC28 | Military |
| SMD5962-9459901MYX | 5V 8Kx8 AutoStore nvSRAM LCC28 | Military |
| SMD5962-9459903MXA | 5V 8Kx8 AutoStore nvSRAM CDIP28-300 | Military |
| SMD5962-9459903MXC | 5V 8Kx8 AutoStore nvSRAM CDIP28-300 | Military |
| SMD5962-9459903MXX | 5V 8Kx8 AutoStore nvSRAM CDIP28-300 | Military |
| SMD5962-9459903MYA | 5V 8Kx8 AutoStore nvSRAM LCC28 | Military |
| SMD5962-9459903MYX | 5V 8Kx8 AutoStore nvSRAM LCC28 | Military |
| STK12C68-5C35M | 5V 8Kx8 AutoStore nvSRAM CDIP28-300 | Military |
| STK12C68-5C55M | 5V 8Kx8 AutoStore nvSRAM CDIP28-300 | Military |
| STK12C68-5K35M | 5V 8Kx8 AutoStore nvSRAM CDIP28-300 | Military |
| STK12C68-5K55M | 5V 8Kx8 AutoStore nvSRAM CDIP28-300 | Military |
| STK12C68-5L35M | 5V 8Kx8 AutoStore nvSRAM LCC28 | Military |
| STK12C68-5L55M | 5V 8Kx8 AutoStore nvSRAM LCC28 | Military |

Package Diagrams

28-Lead, 330 mil SOIC Gull Wing

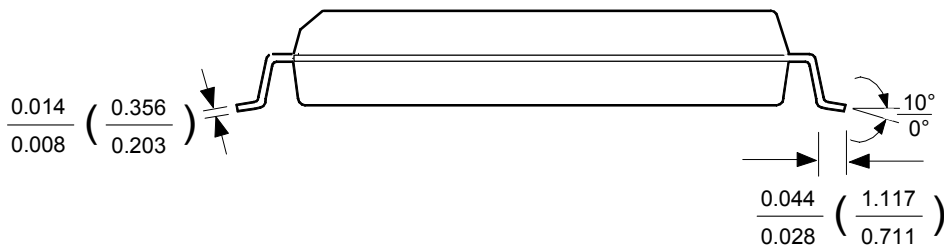
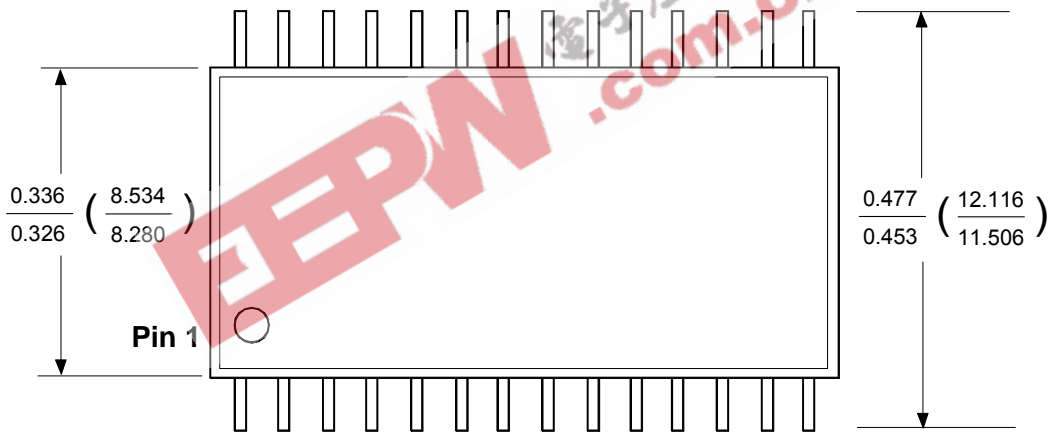
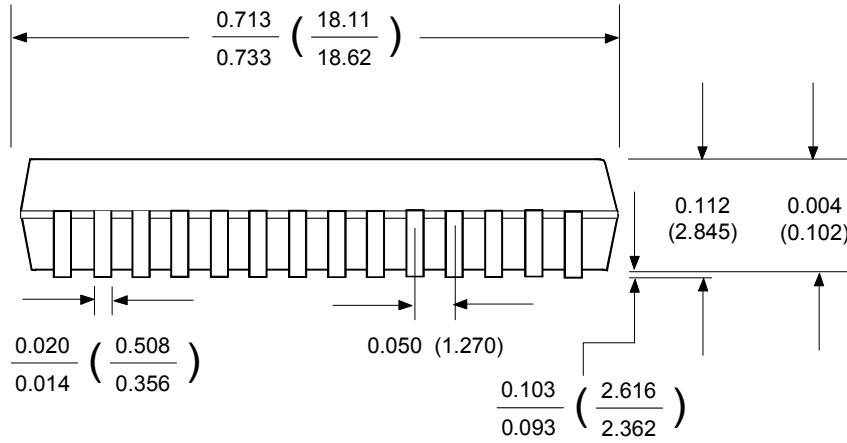

DIM = INCHES $\frac{\text{MIN}}{\text{MAX}}$

DIM = mm ($\frac{\text{MIN}}{\text{MAX}}$)

STK12C68 (SMD5962-94599)

28-Lead 300 mil PDIP

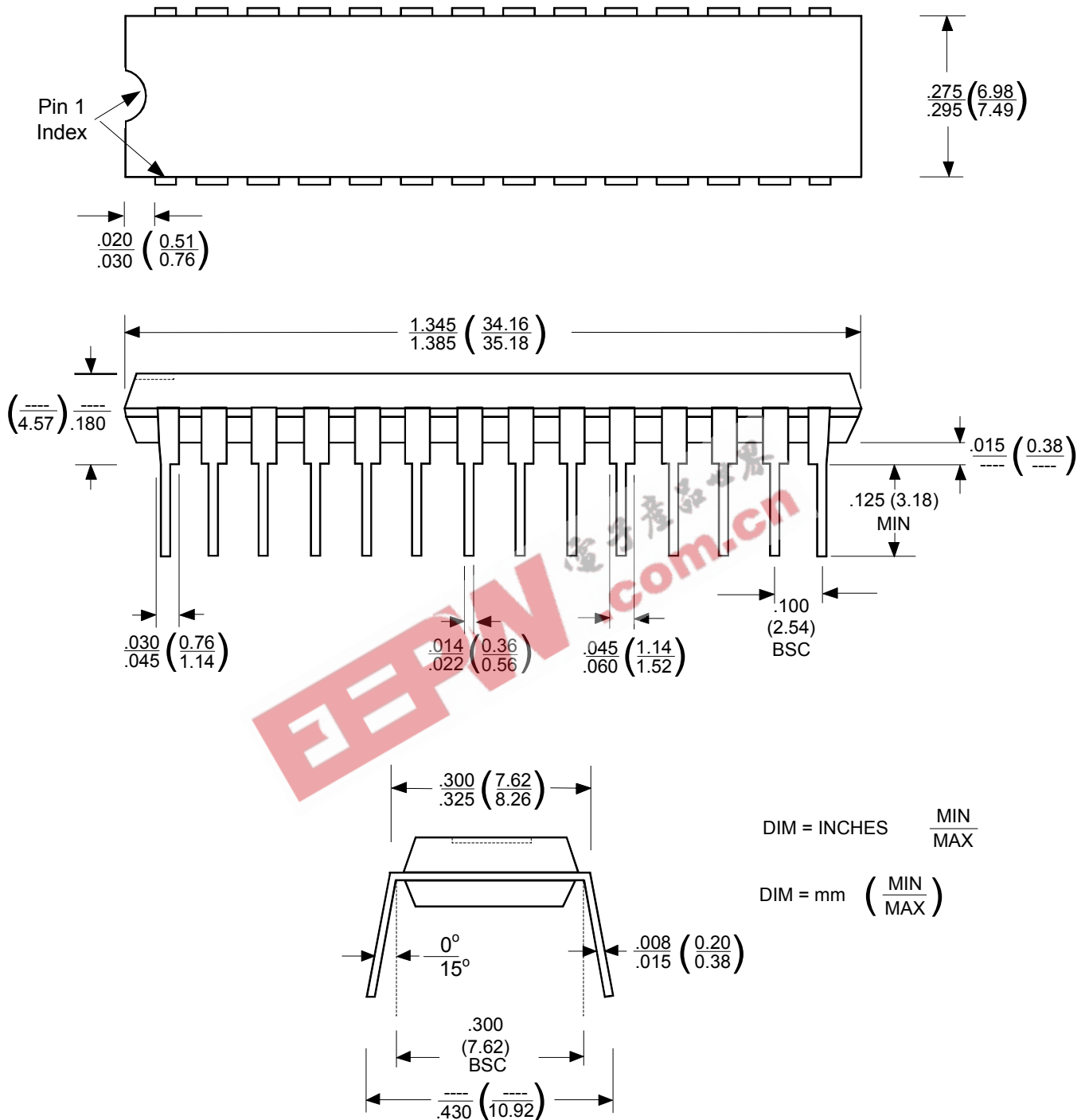

STK12C68 (SMD5962-94599)

28-Lead, 600 mil PDIP

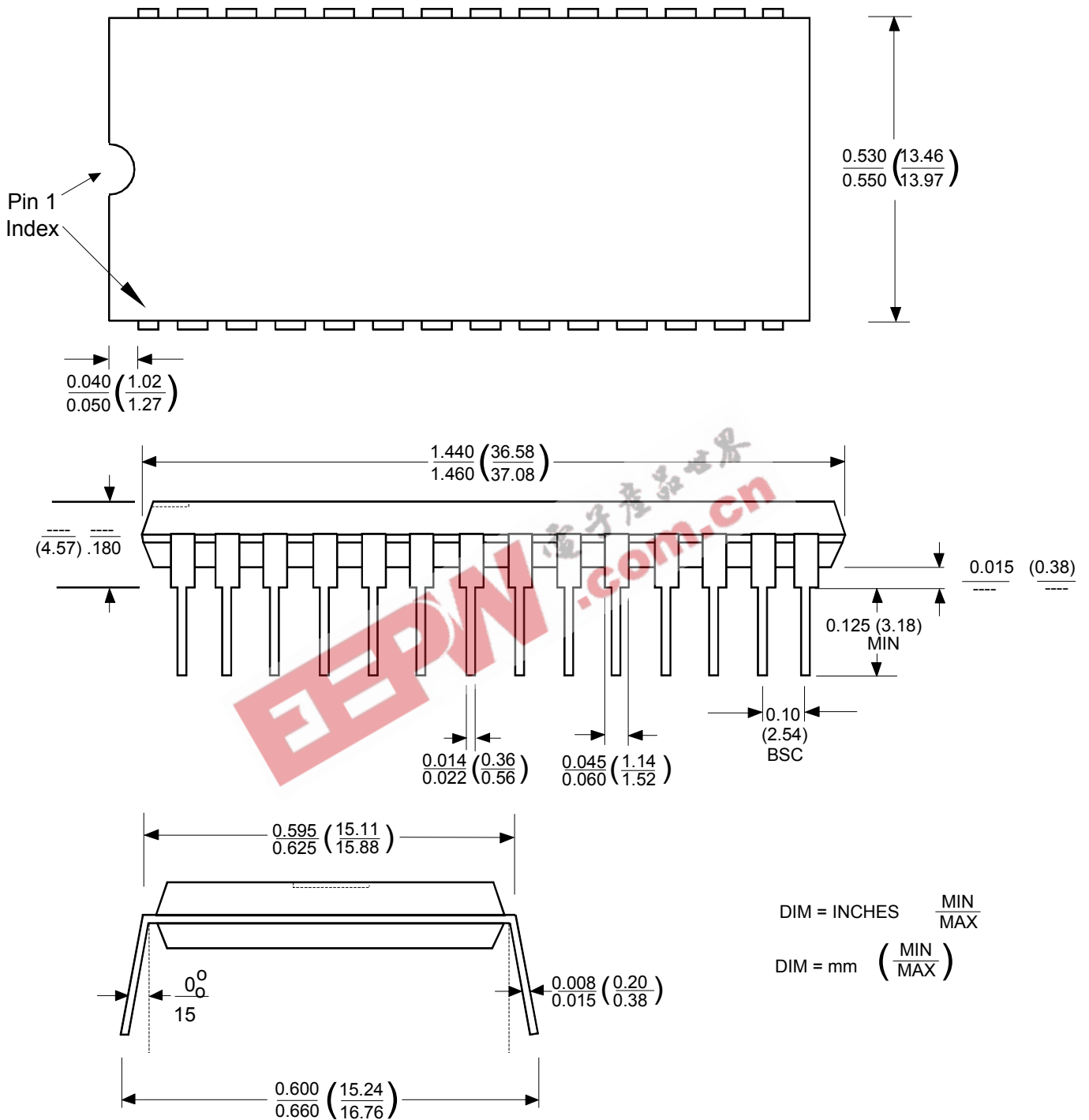

STK12C68 (SMD5962-94599)

28-Lead, 300 mil Side Braze DIL

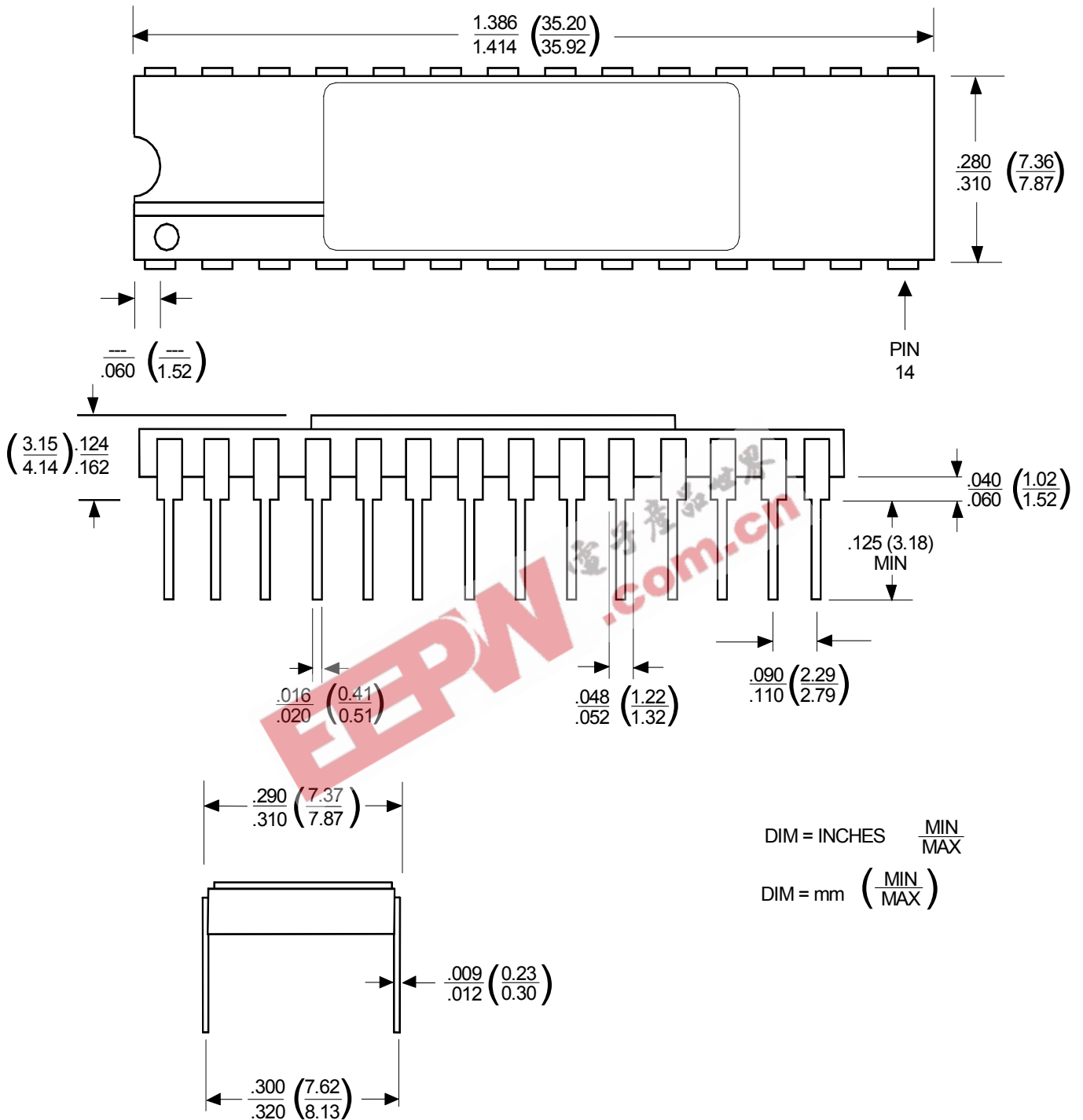

28-Pad, 350 mil Ceramic LCC

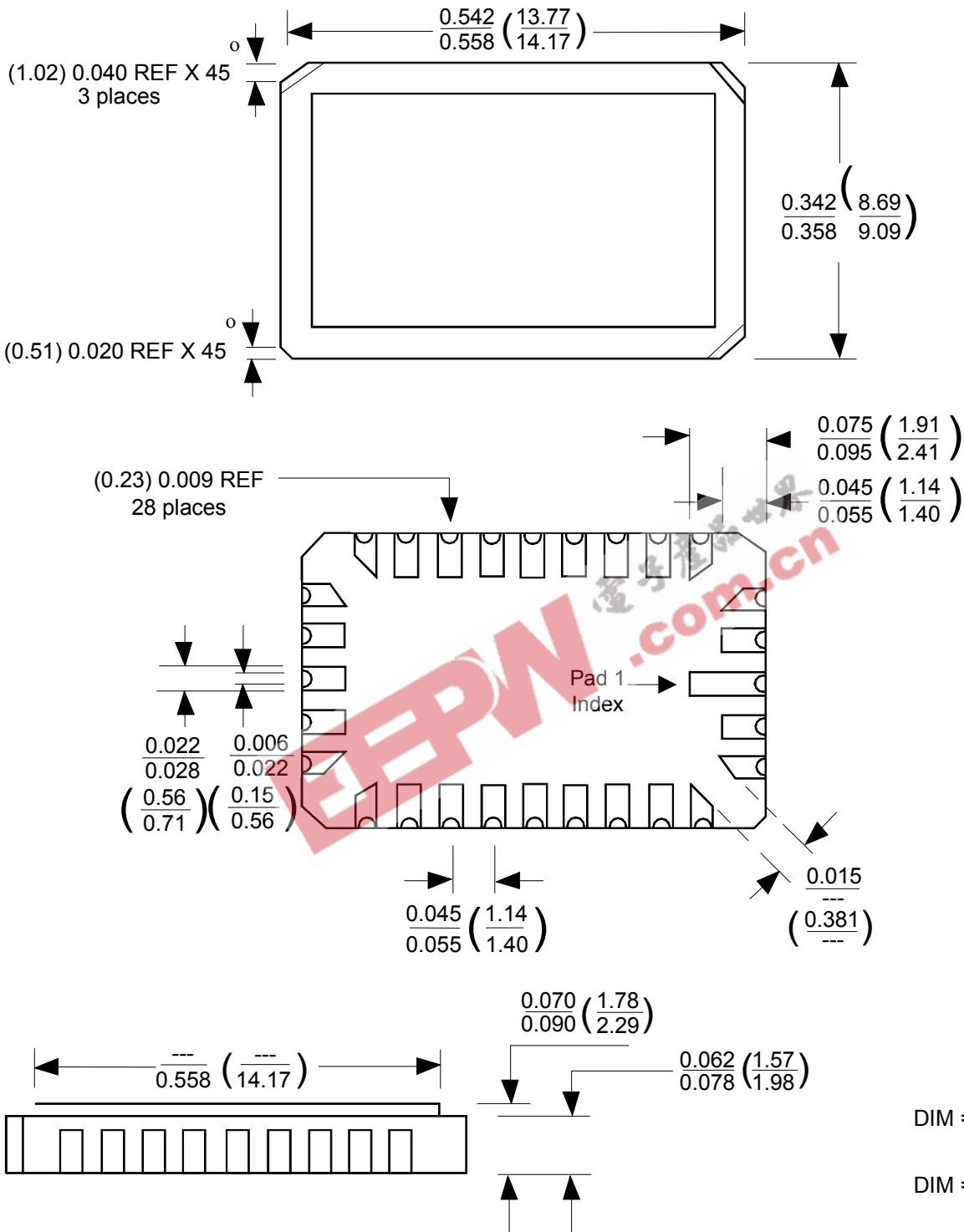

STK12C68 (SMD5962-94599)

Document Revision History

| Revision | Date | Summary |
|----------|----------------|--|
| 0.0 | December 2002 | Combined commercial, industrial and military data sheets. Removed 20 nsec device. |
| 0.1 | January 2003 | Added 35ns SMD to order information |
| 0.2 | July 2003 | Added "28 - SOIC" label to page 1 pinout drawing |
| 0.3 | September 2003 | Added lead-free lead finish |
| 0.4 | October 2003 | Restored "W" 600 mil DIP package to ordering information |
| 0.5 | March 2006 | Removed Commercial 35 ns and leaded lead finish, Removed Military 45ns device |
| 0.6 | August 2006 | Reformat SMD Ordering Information to SDDC Part Number Format |
| 0.7 | February 2007 | Add Fast Power-Down Slew Rate Information Restore Comm/Ind C & L Package Options Add Tape Reel Ordering Options Add Product Ordering Code Listing Add Package Outline Drawings Reformat Entire Document |

SIMTEK STK12C68 Datasheet, February 2007

Copyright 2007, Simtek Corporation. All rights reserved.

This datasheet may only be printed for the expressed use of Simtek Customers. No part of the datasheet may be reproduced in any other form or means without the express written permission from Simtek Corporation. The information contained in this publication is believed to be accurate, but changes may be made without notice. Simtek does not assume responsibility for, or grant or imply any warranty, including MERCHANTABILITY or FITNESS FOR A PARTICULAR PURPOSE regarding this information, the product or its use. Nothing herein constitutes a license, grant or transfer of any rights to any Simtek patent, copyright, trademark, or other proprietary right.