

FEATURES

- 25, 45 ns Read Access & R/W Cycle Time
- Unlimited Read/Write Endurance
- Pin Compatible with Industry Standard SRAMs
- Software-initiated STORE and RECALL
- Automatic RECALL to SRAM on Power Up
- Unlimited RECALL Cycles
- 1 Million Store Cycles
- 100-Year Non-volatile Data Retention
- Single 5.0V $\pm 10\%$ Power Supply
- Commercial and Industrial Temperatures
- 28-pin 300-mil and 330-mil SOIC Packages (RoHS-Compliant)

DESCRIPTION

The Simtek STK11C88 is a 256Kb fast static RAM with a non-volatile Quantum Trap storage element included with each memory cell.

The SRAM provides the fast access & cycle times, ease of use and unlimited read & write endurance of a normal SRAM.

Data transfers under software control to the non-volatile storage cell (the *STORE* operation). On power up, data is automatically restored to the SRAM (the *RECALL* operation). RECALL operations are also available under software control.

The Simtek nvSRAM is the first monolithic non-volatile memory to offer unlimited writes and reads. It is the highest performance, most reliable non-volatile memory available.

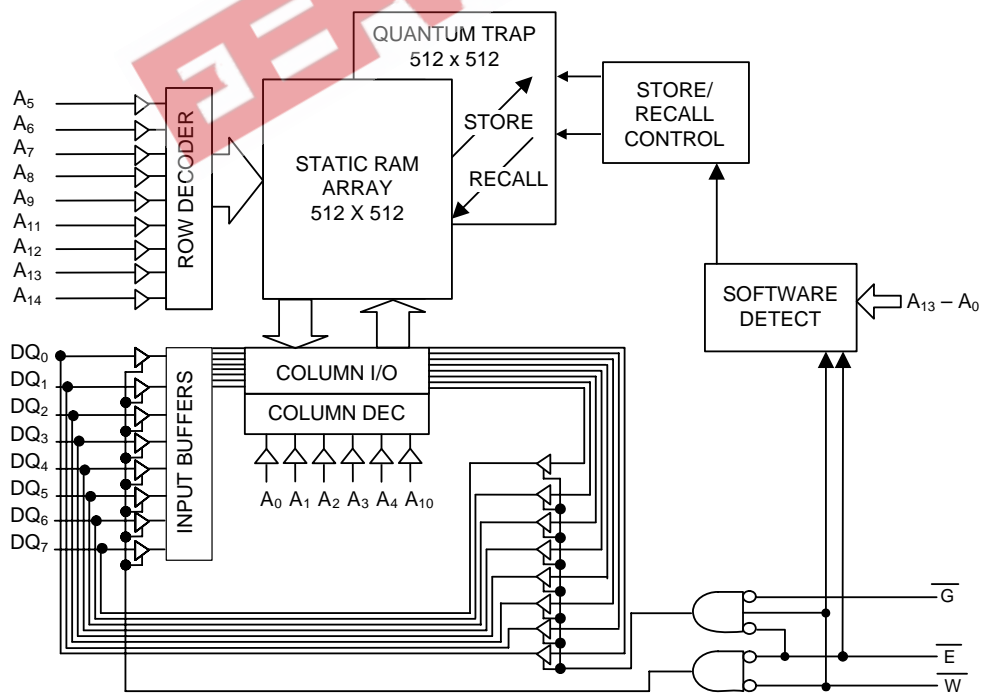
BLOCK DIAGRAM

STK11C88

PIN CONFIGURATIONS

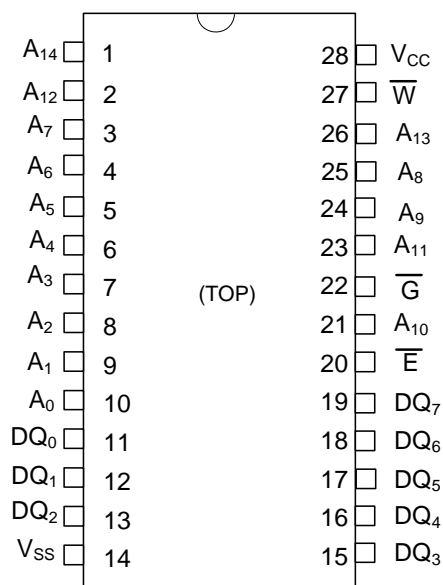

28 - Pin 300 mil SOIC

28 - Pin 330 mil SOIC

PIN DESCRIPTIONS

Pin Name	I/O	Description
A ₁₄ -A ₀	Input	Address: The 15 address inputs select one of 32,768 bytes in the nvSRAM array
DQ ₇ -DQ ₀	I/O	Data: Bi-directional 8-bit data bus for accessing the nvSRAM
\bar{E}	Input	Chip Enable: The active low \bar{E} input selects the device
\bar{W}	Input	Write Enable: The active low \bar{W} enables data on the DQ pins to be written to the address location latched by the falling edge of \bar{E}
\bar{G}	Input	Output Enable: The active low \bar{G} input enables the data output buffers during read cycles. De-asserting \bar{G} high caused the DQ pins to tri-state.
V _{CC}	Power Supply	Power: 5.0V, $\pm 10\%$
V _{SS}	Power Supply	Ground

ABSOLUTE MAXIMUM RATINGS^a

Voltage on Input Relative to Ground -0.5V to 7.0V
 Voltage on Input Relative to V_{SS} -0.6V to (V_{CC} + 0.5V)
 Voltage on DQ₀₋₇ -0.5V to (V_{CC} + 0.5V)
 Temperature under Bias -55°C to 125°C
 Storage Temperature -65°C to 150°C
 Power Dissipation 1W
 DC Output Current (1 output at a time, 1s duration) 15mA

Note a: Stresses greater than those listed under "Absolute Maximum Ratings" may cause permanent damage to the device. This is a stress rating only, and functional operation of the device at conditions above those indicated in the operational sections of this specification is not implied. Exposure to absolute maximum rating conditions for extended periods may affect reliability.

DC CHARACTERISTICS

(V_{CC} = 5.0V ± 10%)

SYMBOL	PARAMETER	COMMERCIAL		INDUSTRIAL		UNITS	NOTES
		MIN	MAX	MIN	MAX		
I _{CC1} ^b	Average V _{CC} Current		97 70		100 70	mA	t _{AVAV} = 25ns t _{AVAV} = 45ns
I _{CC2} ^c	Average V _{CC} Current during STORE		3		3	mA	All Inputs Don't Care, V _{CC} = max
I _{CC3} ^b	Average V _{CC} Current at t _{AVAV} = 200ns 5V, 25°C, Typical		10		10	mA	$\bar{W} \geq (V_{CC} - 0.2V)$ All Others Cycling, CMOS Levels
I _{SB1} ^d	Average V _{CC} Current (Standby, Cycling TTL Input Levels)		30 22		31 23	mA	t _{AVAV} = 25ns, $\bar{E} \geq V_{IH}$ t _{AVAV} = 45ns, $\bar{E} \geq V_{IH}$
I _{SB2} ^d	V _{CC} Standby Current (Standby, Stable CMOS Input Levels)		750		750	μA	$\bar{E} \geq (V_{CC} - 0.2V)$ All Others V _{IN} ≤ 0.2V or ≥ (V _{CC} - 0.2V)
I _{ILK}	Input Leakage Current		±1		±1	μA	V _{CC} = max V _{IN} = V _{SS} to V _{CC}
I _{OLK}	Off-State Output Leakage Current		±5		±5	μA	V _{CC} = max V _{IN} = V _{SS} to V _{CC} , \bar{E} or $\bar{G} \geq V_{IH}$
V _{IH}	Input Logic "1" Voltage	2.2	V _{CC} + .5	2.2	V _{CC} + .5	V	All Inputs
V _{IL}	Input Logic "0" Voltage	V _{SS} - .5	0.8	V _{SS} - .5	0.8	V	All Inputs
V _{OH}	Output Logic "1" Voltage	2.4		2.4		V	I _{OUT} = -4mA
V _{OL}	Output Logic "0" Voltage		0.4		0.4	V	I _{OUT} = 8mA
T _A	Operating Temperature	0	70	-40	85	°C	
V _{CAP}	Storage Capacitance	61	220	61	220	μF	5 Volt rated, 68 μF+20%, -10% Nom.

Note b: I_{CC1} and I_{CC3} are dependent on output loading and cycle rate. The specified values are obtained with outputs unloaded.

Note c: I_{CC2} is the average current required for the duration of the STORE cycle (t_{STORE}).

Note d: $\bar{E} \geq V_{IH}$ will not produce standby current levels until any nonvolatile cycle in progress has timed out.

AC TEST CONDITIONS

Input Pulse Levels 0V to 3V
 Input Rise and Fall Times ≤ 5ns
 Input and Output Timing Reference Levels 1.5V
 Output Load See Figure 1

CAPACITANCE^e (T_A = 25°C, f = 1.0MHz)

SYMBOL	PARAMETER	MAX	UNITS	CONDITIONS
C _{IN}	Input Capacitance	5	pF	ΔV = 0 to 3V
C _{OUT}	Output Capacitance	7	pF	ΔV = 0 to 3V

Note e: These parameters are guaranteed but not tested.

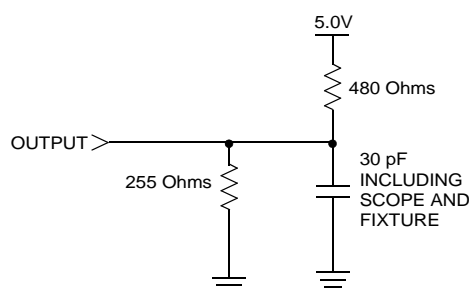

Figure 1: AC Output Loading

STK11C88

SRAM READ CYCLES #1 & #2

(V_{CC} = 5.0V ± 10%)

NO.	SYMBOLS		PARAMETER	STK11C88-25		STK11C88-45		UNITS
	#1, #2	Alt.		MIN	MAX	MIN	MAX	
1	t _{ELQV}	t _{ACS}	Chip Enable Access Time		25		45	ns
2	t _{AVAV} ^f , t _{ELEH} ^f	t _{RC}	Read Cycle Time	25		45		ns
3	t _{AVQV} ^g	t _{AA}	Address Access Time		25		45	ns
4	t _{GLQV}	t _{OE}	Output Enable to Data Valid		10		20	ns
5	t _{AXQX} ^g	t _{OH}	Output Hold after Address Change	5		5		ns
6	t _{ELQX}	t _{LZ}	Address Change or Chip Enable to Output Active	5		5		ns
7	t _{EHQZ} ^h	t _{HZ}	Address Change or Chip Disable to Output Inactive		10		15	ns
8	t _{GLQX}	t _{OLZ}	Output Enable to Output Active	0		0		ns
9	t _{GHQZ} ^h	t _{OHZ}	Output Disable to Output Inactive		10		15	ns
10	t _{ELICCH} ^e	t _{PA}	Chip Enable to Power Active	0		0		ns
11	t _{EHICCL} ^{d, e}	t _{PS}	Chip Disable to Power Standby		25		45	ns

Note f: \bar{W} must be high during SRAM READ cycles and low during SRAM WRITE cycles.

Note g: I/O state assumes \bar{E} , $\bar{G} < V_{IL}$ and $\bar{W} > V_{IH}$; device is continuously selected.

Note h: Measured ± 200mV from steady state output voltage.

SRAM READ CYCLE #1: Address Controlled^{f, g}

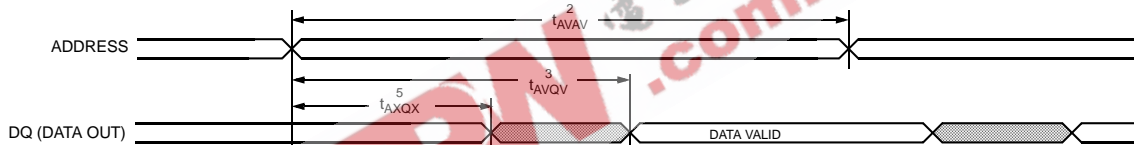

SRAM READ CYCLE #2: \bar{E} and \bar{G} Controlled^f

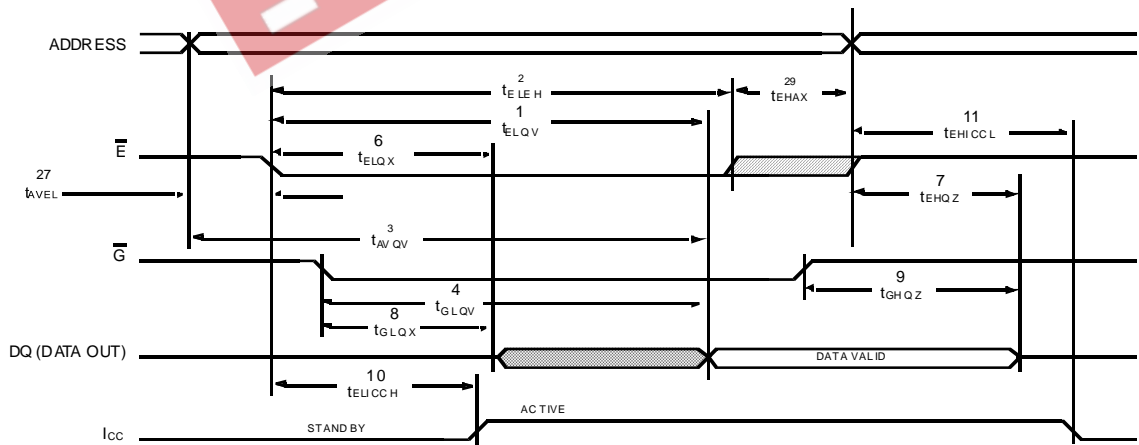

SRAM WRITE CYCLES #1 & #2
(V_{CC} = 5.0V ± 10%)

NO.	SYMBOLS			PARAMETER	STK11C88-25		STK11C88-45		UNITS
	#1	#2	Alt.		MIN	MAX	MIN	MAX	
12	t _{AVAV}	t _{AVAV}	t _{WC}	Write Cycle Time	25		45		ns
13	t _{WLWH}	t _{WLEH}	t _{WP}	Write Pulse Width	20		30		ns
14	t _{ELWH}	t _{ELEH}	t _{CW}	Chip Enable to End of Write	20		30		ns
15	t _{DVWH}	t _{DVEH}	t _{DW}	Data Set-up to End of Write	10		15		ns
16	t _{WHDX}	t _{EHDX}	t _{DH}	Data Hold after End of Write	0		0		ns
17	t _{AVWH}	t _{AVEH}	t _{AW}	Address Set-up to End of Write	20		30		ns
18	t _{AVWL}	t _{AVEL}	t _{AS}	Address Set-up to Start of Write	0		0		ns
19	t _{WHAX}	t _{EHAX}	t _{WR}	Address Hold after End of Write	0		0		ns
20	t _{WLQZ} ^{h, i}		t _{WZ}	Write Enable to Output Disable		10		15	ns
21	t _{WHQX}		t _{OW}	Output Active after End of Write	5		5		ns

Note i: If \bar{W} is low when \bar{E} goes low, the outputs remain in the high-impedance state.
 Note j: \bar{E} or \bar{W} must be $\geq V_{IH}$ during address transitions.

SRAM WRITE CYCLE #1: \bar{W} Controlled^j

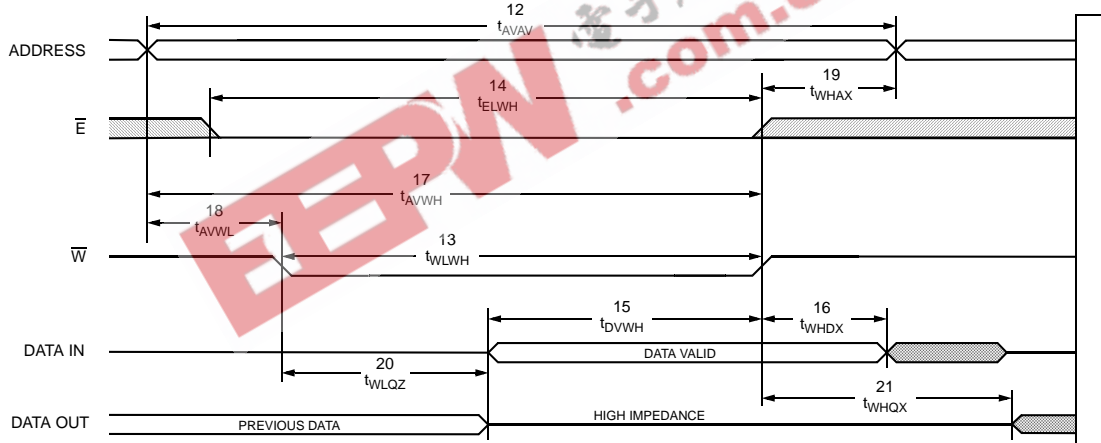

STK11C88

SRAM WRITE CYCLE #2: \bar{E} Controlled^j

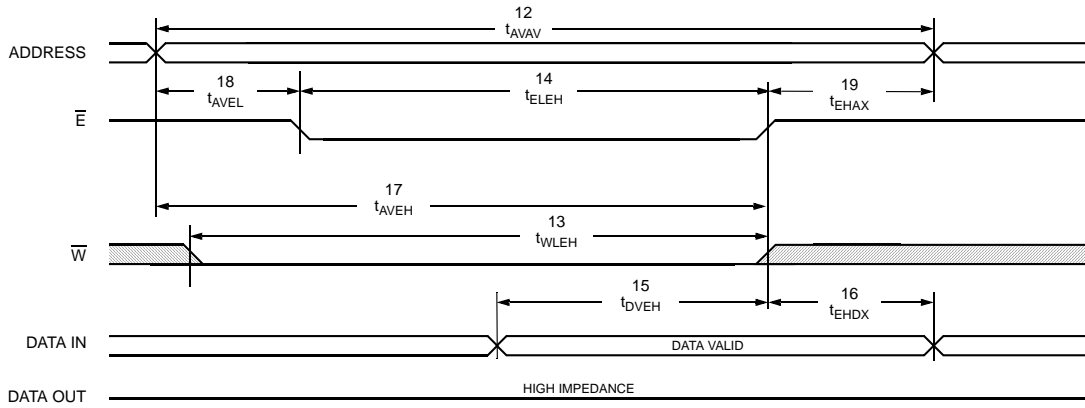

AutoStore™ INHIBIT/POWER-UP RECALL

($V_{CC} = 5.0V \pm 10\%$)

NO.	SYMBOLS	PARAMETER	STK11C88		UNITS	NOTES
	Standard		MIN	MAX		
22	$t_{RESTORE}$	Power-up <i>RECALL</i> Duration		550	μs	k
23	t_{STORE}	<i>STORE</i> Cycle Duration		10	ms	g
24	V_{SWITCH}	Low Voltage Trigger Level	4.0	4.5	V	
25	V_{RESET}	Low Voltage Reset Level		3.6	V	

Note k: $t_{RESTORE}$ starts from the time V_{CC} rises above V_{SWITCH} .

AutoStore™ INHIBIT/POWER-UP RECALL

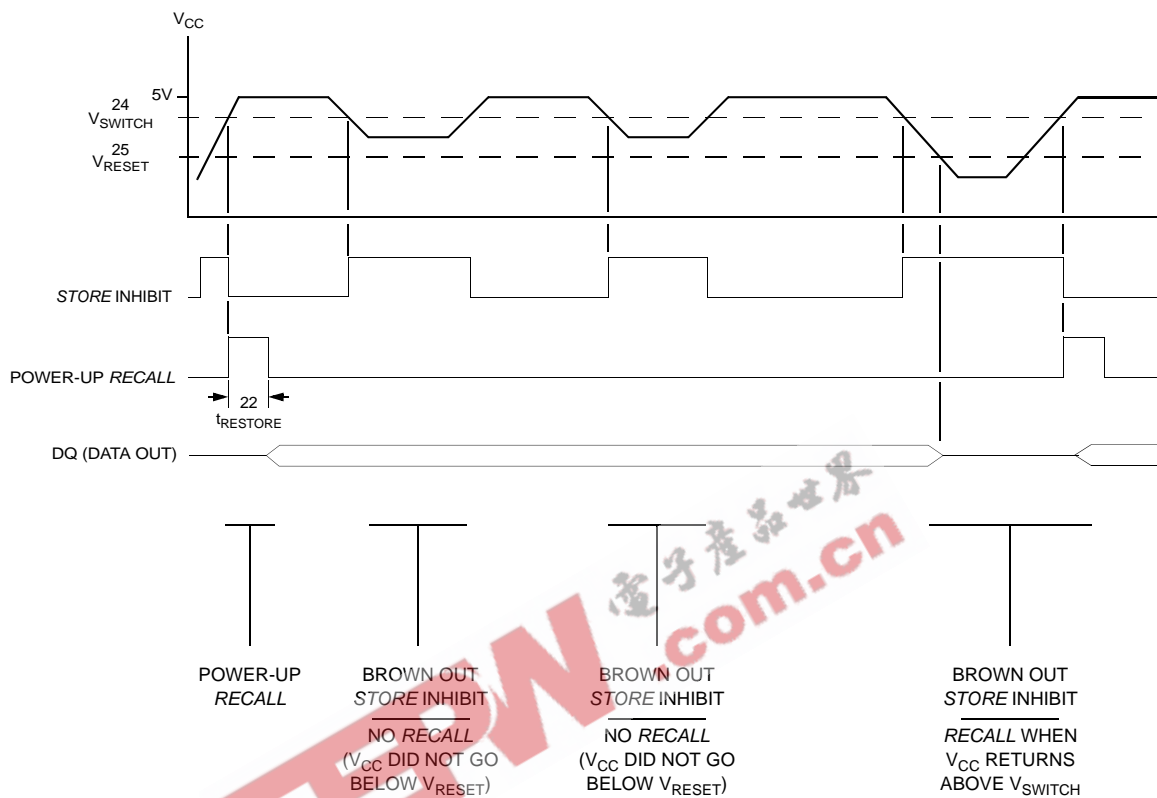

STK11C88

SOFTWARE STORE/RECALL MODE SELECTION

\bar{E}	\bar{W}	A ₁₃ - A ₀ (hex)	MODE	I/O	NOTES
L	H	0E38	Read SRAM	Output Data	l, m
		31C7	Read SRAM	Output Data	
		03E0	Read SRAM	Output Data	
		3C1F	Read SRAM	Output Data	
		303F	Read SRAM	Output Data	
		0FC0	Nonvolatile STORE	Output High Z	
L	H	0E38	Read SRAM	Output Data	l, m
		31C7	Read SRAM	Output Data	
		03E0	Read SRAM	Output Data	
		3C1F	Read SRAM	Output Data	
		303F	Read SRAM	Output Data	
		0C63	Nonvolatile RECALL	Output High Z	

Note l: The six consecutive addresses must be in the order listed. \bar{W} must be high during all six consecutive \bar{E} controlled cycles to enable a nonvolatile cycle.

Note m: While there are 15 addresses on the STK11C88, only the lower 14 are used to control software modes.

SOFTWARE STORE/RECALL CYCLE^{n, o}

(V_{CC} = 5.0V ± 10%)

NO.	SYMBOLS	PARAMETER	STK11C88-25		STK11C88-45		UNITS
			MIN	MAX	MIN	MAX	
26	t _{AVAV}	STORE/RECALL Initiation Cycle Time	25		45		ns
27	t _{AVEL} ⁿ	Address Set-up Time	0		0		ns
28	t _{ELEH} ⁿ	Clock Pulse Width	20		30		ns
29	t _{ELAX} ⁿ	Address Hold Time	20		20		ns
30	t _{RECALL} ⁿ	RECALL Duration		20		20	μs

Note n: The software sequence is clocked on the falling edge of \bar{E} controlled READs without involving \bar{G} (double clocking will abort the sequence). See application note: MA0002 <http://www.simtek.com/attachments/AppNote02.pdf>.

Note o: The six consecutive addresses must be in the order listed in the Software STORE/RECALL Mode Selection Table: (0E38, 31C7, 03E0, 3C1F, 303F, 0FC0) for a STORE cycle or (0E38, 31C7, 03E0, 3C1F, 303F, 0C63) for a RECALL cycle. \bar{W} must be high during all six consecutive cycles.

SOFTWARE STORE/RECALL CYCLE: \bar{E} Controlled^o

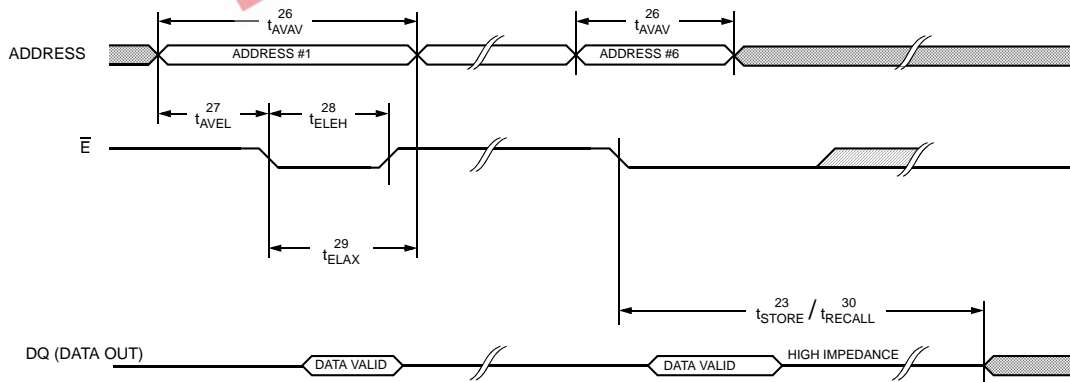

nvSRAM OPERATION

The STK11C88 is a versatile memory chip that provides several modes of operation. The STK11C88 operates like a standard 32K x 8 SRAM. A 32K x 8 array of non-volatile storage elements shadow the SRAM. SRAM data can be copied to non-volatile memory or non-volatile data can be recalled to the SRAM.

NOISE CONSIDERATIONS

Note that the STK11C88 is a high-speed memory and so must have a high-frequency bypass capacitor of approximately 0.1 μ F connected between V_{CC} and V_{SS} , using leads and traces that are as short as possible. As with all high-speed CMOS ICs, normal careful routing of power, ground and signals will help prevent noise problems.

SRAM READ

The STK11C88 performs a READ cycle whenever \bar{E} and \bar{G} are low and \bar{W} is high. The address specified on pins A_{0-14} determines which of the 32,768 data bytes will be accessed. When the READ is initiated by an address transition, the outputs will be valid after a delay of t_{AVQV} (READ cycle #1). If the READ is initiated by \bar{E} or \bar{G} , the outputs will be valid at t_{ELQV} or at t_{GLQV} , whichever is later (READ cycle #2). The data outputs will repeatedly respond to address changes within the t_{AVQV} access time without the need for transitions on any control input pins, and will remain valid until another address change or until \bar{E} or \bar{G} is brought high.

SRAM WRITE

A WRITE cycle is performed whenever \bar{E} and \bar{W} are low. The address inputs must be stable prior to entering the WRITE cycle and must remain stable until either \bar{E} or \bar{W} goes high at the end of the cycle. The data on the common I/O pins DQ_{0-7} will be written into the memory if it is valid t_{DVWH} before the end of a \bar{W} controlled WRITE or t_{DVEH} before the end of an \bar{E} controlled WRITE.

It is recommended that \bar{G} be kept high during the entire WRITE cycle to avoid data bus contention on the common I/O lines. If \bar{G} is left low, internal circuitry will turn off the output buffers t_{WLQZ} after \bar{W} goes low.

SOFTWARE NONVOLATILE STORE

The STK11C88 software STORE cycle is initiated by executing sequential READ cycles from six specific address locations. During the STORE cycle an erase of the previous nonvolatile data is first performed, followed by a program of the nonvolatile elements. The program operation copies the SRAM data into nonvolatile memory. Once a STORE cycle is initiated, further input and output are disabled until the cycle is completed.

Because a sequence of READs from specific addresses is used for STORE initiation, it is important that no other READ or WRITE accesses intervene in the sequence or the sequence will be aborted and no STORE or RECALL will take place.

To initiate the software STORE cycle, the following READ sequence must be performed:

1. Read address	0E38 (hex)	Valid READ
2. Read address	31C7 (hex)	Valid READ
3. Read address	03E0 (hex)	Valid READ
4. Read address	3C1F (hex)	Valid READ
5. Read address	303F (hex)	Valid READ
6. Read address	0FC0 (hex)	Initiate STORE cycle

The software sequence must be clocked with \bar{E} controlled READs.

Once the sixth address in the sequence has been entered, the STORE cycle will commence and the chip will be disabled. It is important that READ cycles and not WRITE cycles be used in the sequence, although it is not necessary that \bar{G} be low for the sequence to be valid. After the t_{STORE} cycle time has been fulfilled, the SRAM will again be activated for READ and WRITE operation.

SOFTWARE NONVOLATILE RECALL

A software RECALL cycle is initiated with a sequence of READ operations in a manner similar to the software STORE initiation. To initiate the RECALL cycle, the following sequence of READ operations must be performed:

1. Read address	0E38 (hex)	Valid READ
2. Read address	31C7 (hex)	Valid READ
3. Read address	03E0 (hex)	Valid READ
4. Read address	3C1F (hex)	Valid READ
5. Read address	303F (hex)	Valid READ
6. Read address	0C63 (hex)	Initiate RECALL cycle

STK11C88

Internally, *RECALL* is a two-step procedure. First, the SRAM data is cleared, and second, the nonvolatile information is transferred into the SRAM cells. After the t_{RECALL} cycle time the SRAM will once again be ready for READ and WRITE operations. The *RECALL* operation in no way alters the data in the Nonvolatile Elements. The nonvolatile data can be recalled an unlimited number of times.

POWER-UP RECALL

During power up, or after any low-power condition ($V_{\text{CC}} < V_{\text{RESET}}$), an internal *RECALL* request will be latched. When V_{CC} once again exceeds the sense voltage of V_{SWITCH} , a *RECALL* cycle will automatically be initiated and will take t_{RESTORE} to complete.

If the STK11C88 is in a WRITE state at the end of power-up *RECALL*, the SRAM data will be corrupted. To help avoid this situation, a 10K Ohm resistor should be connected either between \bar{W} and system V_{CC} or between \bar{E} and system V_{CC} .

HARDWARE PROTECT

The STK11C88 offers hardware protection against inadvertent *STORE* operation during low-voltage conditions. When $V_{\text{CC}} < V_{\text{SWITCH}}$, all software *STORE* operations are inhibited.

LOW AVERAGE ACTIVE POWER

The STK11C88 draws significantly less current when it is cycled at times longer than 50ns. Figure 2 shows the relationship between I_{CC} and READ cycle time. Worst-case current consumption is shown for both CMOS and TTL input levels (commercial temperature range, $V_{\text{CC}} = 5.5\text{V}$, 100% duty cycle on chip enable). Figure 3 shows the same relationship for WRITE cycles. If the chip enable duty cycle is less than 100%, only standby current is drawn when the chip is disabled. The overall average current drawn by the STK11C88 depends on the following items: 1) CMOS vs. TTL input levels; 2) the duty cycle of chip enable; 3) the overall cycle rate for accesses; 4) the ratio of READS to WRITES; 5) the operating temperature; 6) the V_{CC} level; and 7) I/O loading.

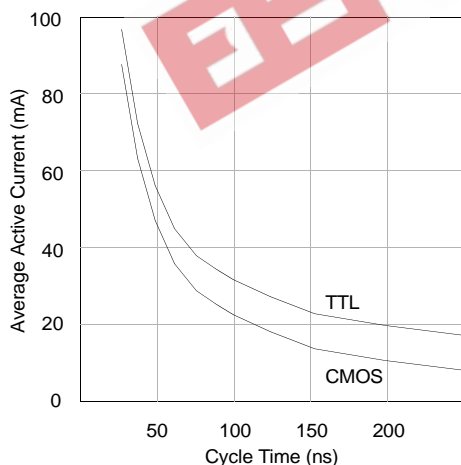

Figure 2: I_{CC} (max) Reads

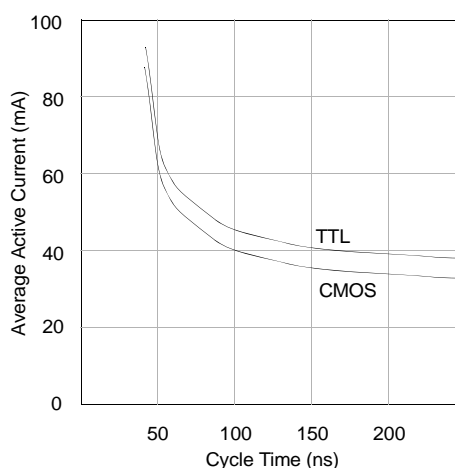

Figure 3: I_{CC} (max) Writes

BEST PRACTICES

nvSRAM products have been used effectively for over 15 years. While ease-of-use is one of the product's main system values, experience gained working with hundreds of applications has resulted in the following suggestions as best practices:

- The non-volatile cells in an nvSRAM are programmed on the test floor during final test and quality assurance. Incoming inspection routines at customer or contract manufacturer's sites will sometimes reprogram these values. Final NV patterns are typically repeating patterns of AA, 55, 00, FF, A5, or 5A. End product's firmware should not assume an NV array is in a set programmed state. Routines that check memory content values to determine first time system configuration, cold or warm boot status, etc. should always program a unique NV pattern (e.g., complex 4-byte pattern of 46 E6 49 53 hex or more random bytes) as part of the final system manufacturing test to ensure these system routines work consistently.
- Power up boot firmware routines should rewrite the nvSRAM into the desired state. While the nvSRAM is shipped in a preset state, best practice is to again rewrite the nvSRAM into the desired state as a safeguard against events that might flip the bit inadvertently (program bugs, incoming inspection routines, etc.).

EEPW 电子產品世界
.com.cn

STK11C88

ORDERING INFORMATION

STK11C88 - N F 25 I TR

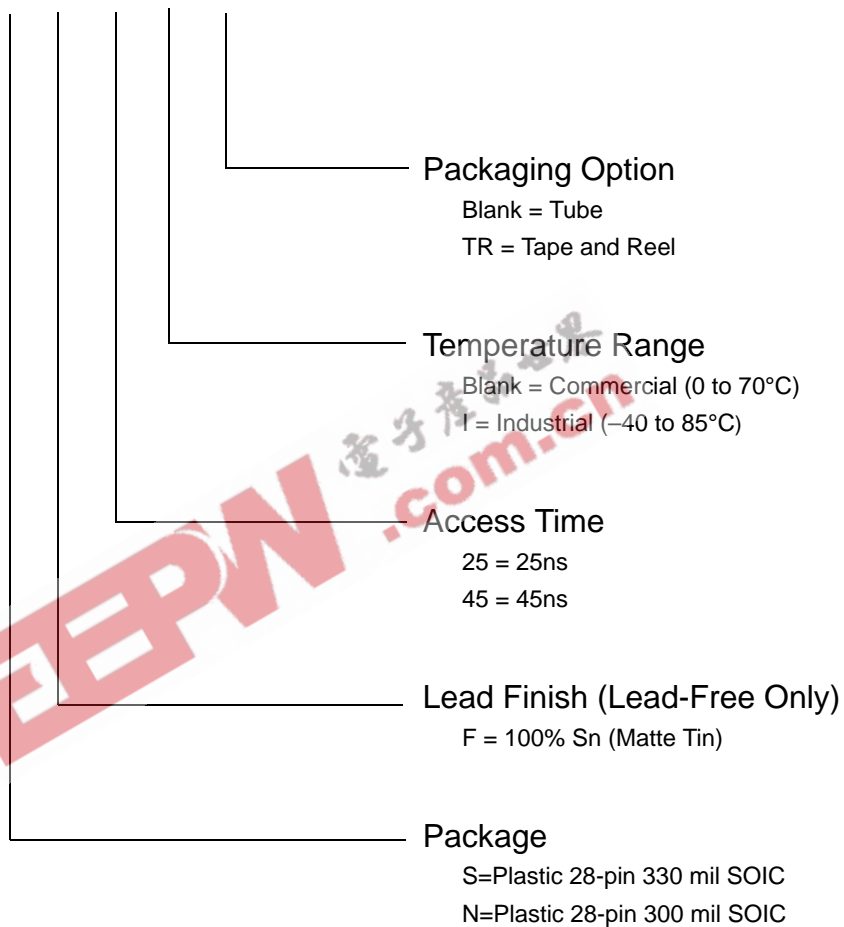

Ordering Codes

Part Number	Description	Access Times	Temperature
STK11C88-SF25	5V 32Kx8 SoftStore nvSRAM SOP28-330	25 ns access time	Commercial
STK11C88-SF45	5V 32Kx8 SoftStore nvSRAM SOP28-330	45 ns access time	Commercial
STK11C88-NF25	5V 32Kx8 SoftStore nvSRAM SOP28-300	25 ns access time	Commercial
STK11C88-NF45	5V 32Kx8 SoftStore nvSRAM SOP28-300	45 ns access time	Commercial
STK11C88-SF25TR	5V 32Kx8 SoftStore nvSRAM SOP28-330	25 ns access time	Commercial
STK11C88-SF45TR	5V 32Kx8 SoftStore nvSRAM SOP28-330	45 ns access time	Commercial
STK11C88-NF25TR	5V 32Kx8 SoftStore nvSRAM SOP28-300	25 ns access time	Commercial
STK11C88-NF45TR	5V 32Kx8 SoftStore nvSRAM SOP28-300	45 ns access time	Commercial
STK11C88-SF25I	5V 32Kx8 SoftStore nvSRAM SOP28-330	25 ns access time	Industrial
STK11C88-SF45I	5V 32Kx8 SoftStore nvSRAM SOP28-330	45 ns access time	Industrial
STK11C88-NF25I	5V 32Kx8 SoftStore nvSRAM SOP28-300	25 ns access time	Industrial
STK11C88-NF45I	5V 32Kx8 SoftStore nvSRAM SOP28-300	45 ns access time	Industrial
STK11C88-SF25ITR	5V 32Kx8 SoftStore nvSRAM SOP28-330	25 ns access time	Industrial
STK11C88-SF45ITR	5V 32Kx8 SoftStore nvSRAM SOP28-330	45 ns access time	Industrial
STK11C88-NF25ITR	5V 32Kx8 SoftStore nvSRAM SOP28-300	25 ns access time	Industrial
STK11C88-NF45ITR	5V 32Kx8 SoftStore nvSRAM SOP28-300	45 ns access time	Industrial

Package Drawings

28 - Pin 300 mil SOIC

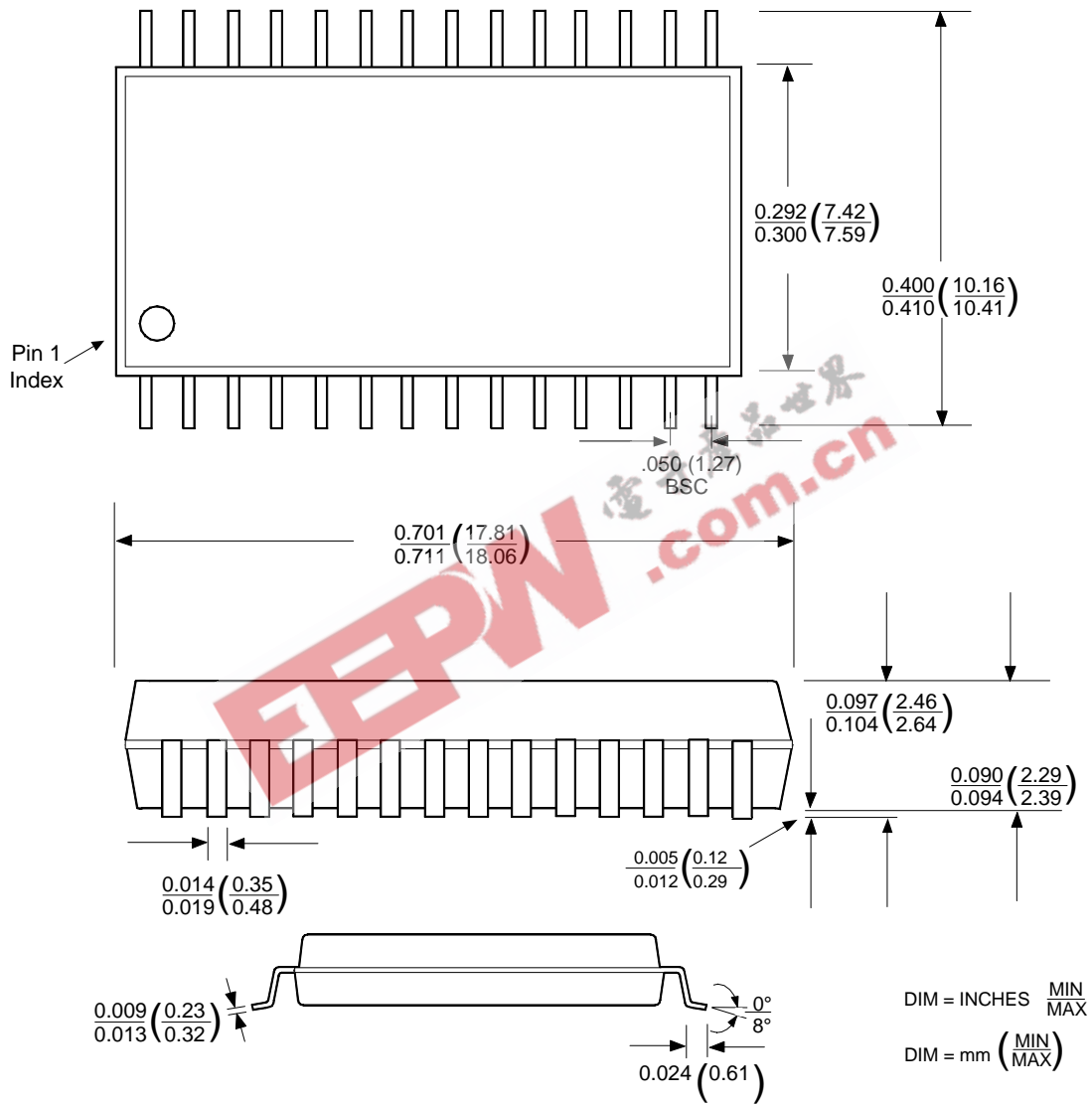

28 - Pin 330 mil SOIC

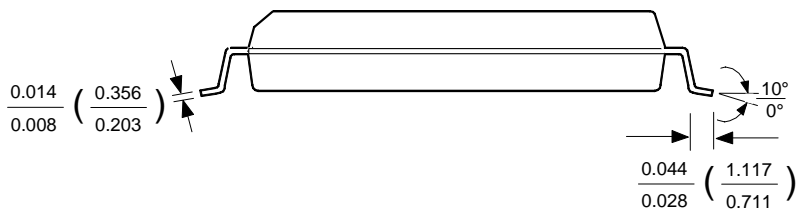
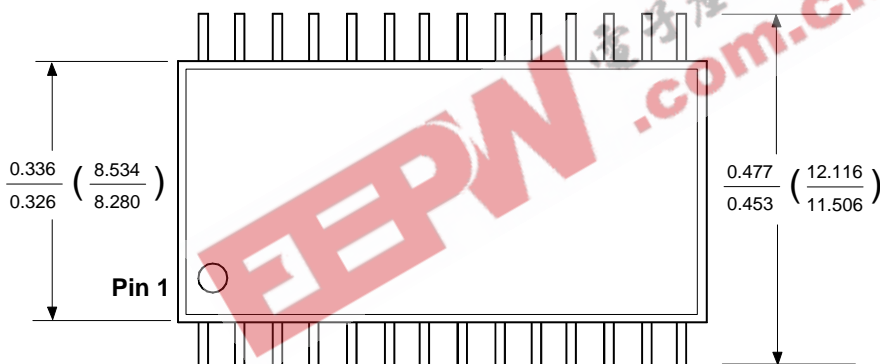
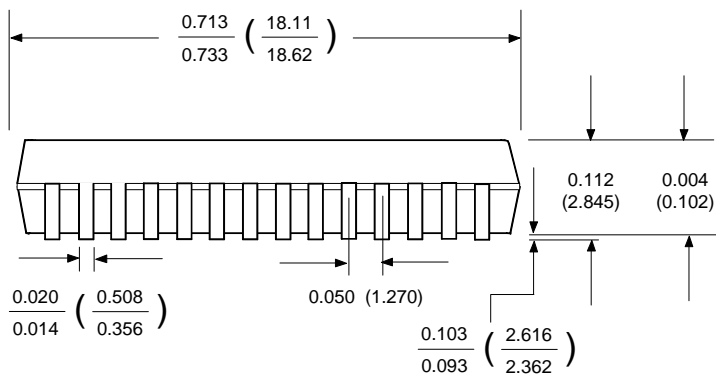

DIM = INCHES $\frac{\text{MIN}}{\text{MAX}}$
 DIM = mm ($\frac{\text{MIN}}{\text{MAX}}$)

STK11C88

Document Revision History

Revision	Date	Summary
0.0	December 2002	Removed 20 nsec device
0.1	September 2003	Added lead free lead finish
0.2	March 2006	Removed 35ns device, Removed Leaded Lead Finish, Removed DIP packages.
0.3	February 2007	Add fast power-down slew rate information Add Tape & Reel Ordering Options Add Product Ordering Code Listing Add Package Outline Drawings Reformat Entire Document
0.4	July 2007	extend definition of t_{HZ} (#7) update fig. SRAM READ CYCLE #2, SRAM WRITE CYCLE #1, Note l and Note n to clarify product usage
2.0	January 2008	Page 4: in SRAM Read Cycles #1 & #2 table, revised description for t_{EHQZ} and changed Symbol #2 to t_{ELEH} for Read Cycle Time; updated SRAM Read Cycle #2 timing diagram and changed title to add \bar{G} controlled. Page 11: added best practices section. Page 13: added access times column to the Ordering Codes.

SIMTEK STK11C88 Datasheet, January 2008

Copyright 2008, Simtek Corporation. All rights reserved.

This datasheet may only be printed for the expressed use of Simtek Customers. No part of the datasheet may be reproduced in any other form or means without the express written permission from Simtek Corporation. The information contained in this publication is believed to be accurate, but changes may be made without notice. Simtek does not assume responsibility for, or grant or imply any warranty, including MERCHANTABILITY or FITNESS FOR A PARTICULAR PURPOSE regarding this information, the product or its use. Nothing herein constitutes a license, grant or transfer of any rights to any Simtek patent, copyright, trademark, or other proprietary right.