

**STK4211V**

2-Channel 70 W min AF Power Amplifier (Split Power Supply)

Features

- The inclusion of a muting circuit on-chip allows all types of impulse noise to be excluded.
- Current mirror circuit application reduces distortion to 0.008%.
- Pin compatible with the STK4201II Series (THD = 0.4%) and the STK4141X Series (THD = 0.02%)

Package Dimensions

unit: mm

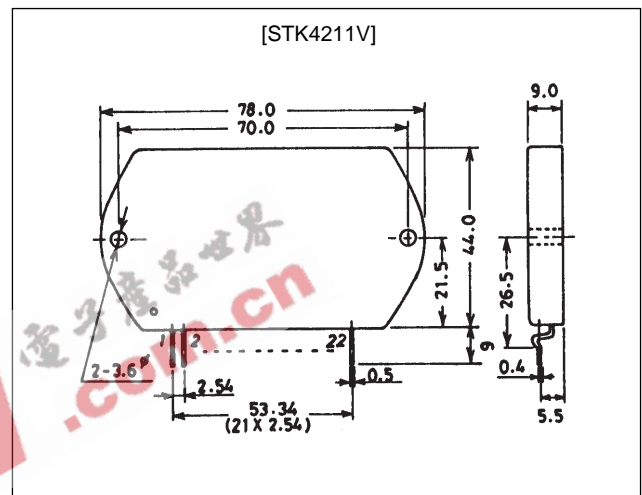
4086A

Specifications

Maximum Ratings at $T_a = 25^\circ\text{C}$

Parameter	Symbol	Condition	Rating	Unit
Maximum supply voltage	V_{CC} max		± 62	V
Thermal resistance	θ_{j-c}		1.5	$^\circ\text{C}/\text{W}$
Junction temperature	T_j		150	$^\circ\text{C}$
Operating case temperature	T_c		125	$^\circ\text{C}$
Storage temperature	T_{stg}		-30 to $+125$	$^\circ\text{C}$
Available time for load shorted	t_S^*	$V_{CC} = \pm 43\text{ V}$, $R_L = 8\ \Omega$, $f = 50\text{ Hz}$, $P_O = 70\text{ W}$	1	sec

Note: Use a constant voltage power supply as the test power supply unless otherwise specified.

* Use the transformer power supply shown on the next page when measuring the available time for load shorted and the output noise voltage.

Recommended Operating Conditions at $T_a = 25^\circ\text{C}$

Parameter	Symbol	Condition	Rating	Unit
Recommended supply voltage	V_{CC}		± 43	V
Load resistance	R_L		8	Ω

STK4211V

Operating Characteristics at $T_a = 25^\circ\text{C}$, $V_{CC} = \pm 50\text{ V}$, $R_L = 8\ \Omega$ (noninductive load), $R_G = 600\ \Omega$, $V_G = 40\ \text{dB}$

Parameter	Symbol	Condition	Rating			Unit
			min	typ	max	
Quiescent current	I_{CCO}	$V_{CC} = \pm 50.5\text{ V}$	20	40	100	mA
Output power	P_O	THD = 0.08%, $f = 20\text{ Hz to } 20\text{ kHz}$	70			W
Total harmonic distortion	THD	$P_O = 1.0\text{ W}$, $f = 1\text{ kHz}$			0.08	%
Frequency response	f_L, f_H	$P_O = 1.0\text{ W}$, $\pm 3\text{ dB}$		20 to 50 k		Hz
Input resistance	r_i	$P_O = 1.0\text{ W}$, $f = 1\text{ kHz}$		55		k Ω
Output noise voltage	V_{NO}^*	$V_{CC} = \pm 50.5\text{ V}$, $R_G = 10\text{ k}\Omega$			1.2	mVrms
Neutral voltage	V_N	$V_{CC} = \pm 50.5\text{ V}$	-70	0	+70	mV
Muting voltage	V_M		-2	-5	-10	V

Note: Use a constant voltage power supply as the test power supply unless otherwise specified.

* The output noise voltage is the peak value measured with an averaging rms scale volt meter. The noise voltage waveform should not include pulse noise.

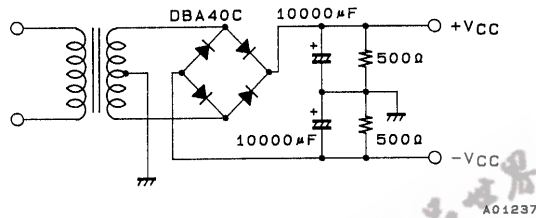

Specified Transformer Power Supply
(MG-200 equivalent)

Equivalent Circuit

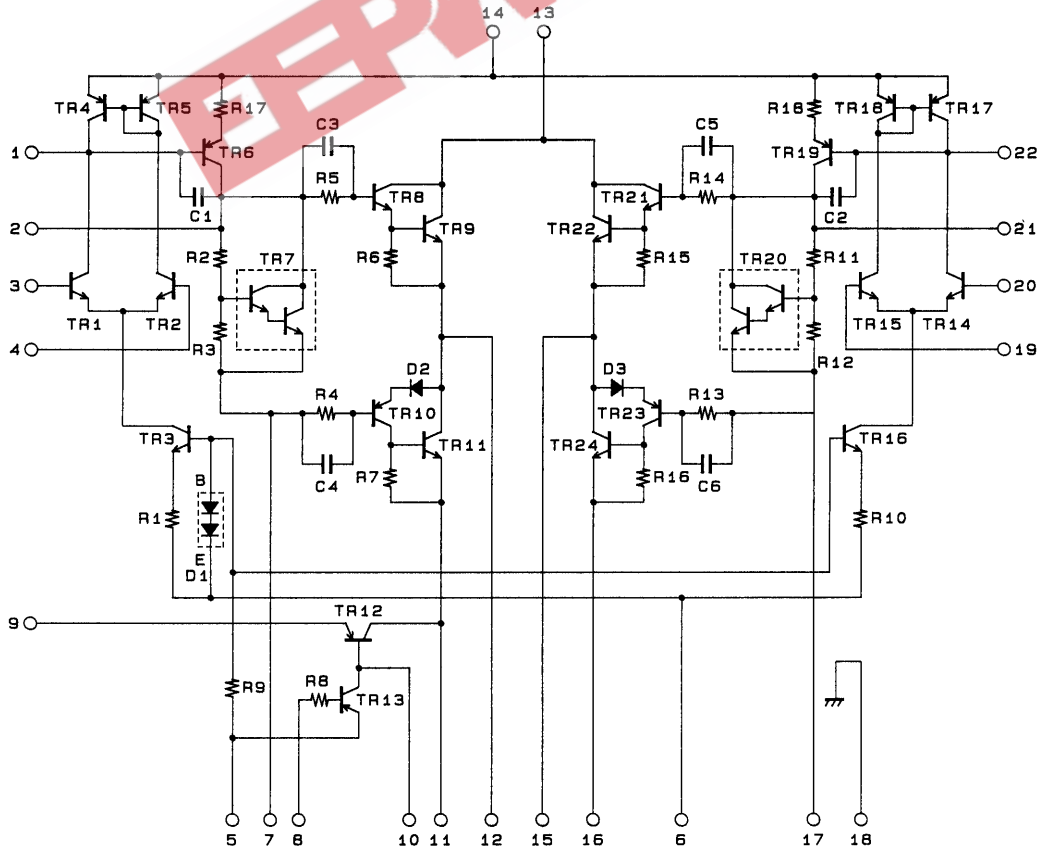

A01541

Sample Application Circuit: 2-Channel 70 W min AF Power Amplifier

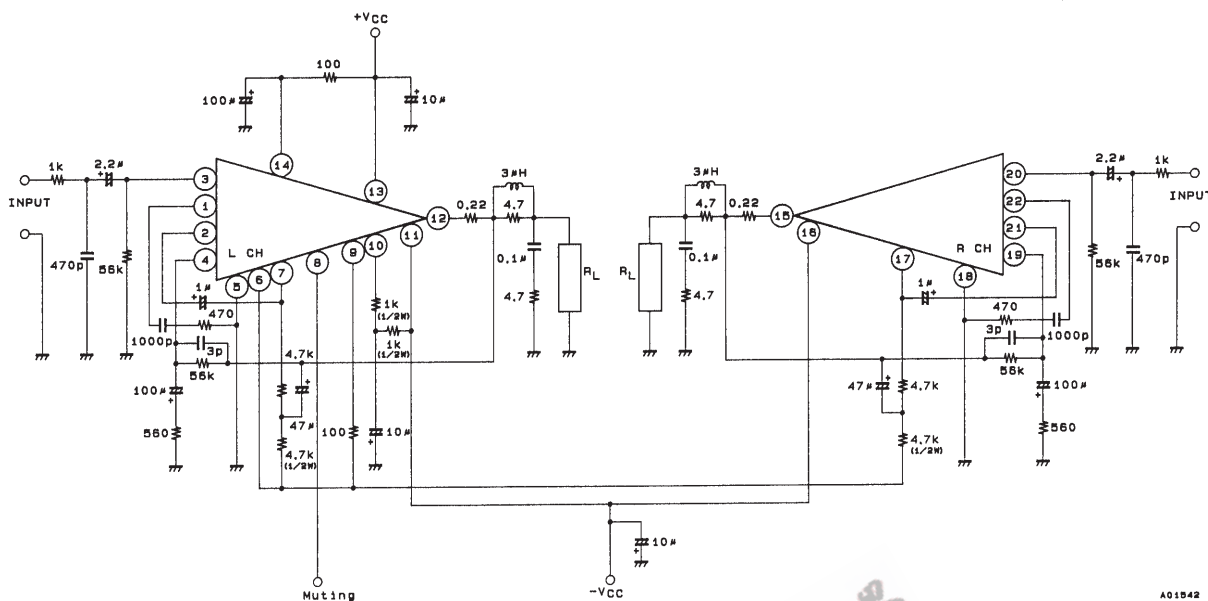

A01042

Unit (resistance: Ω, capacitance: F)



- No products described or contained herein are intended for use in surgical implants, life-support systems, aerospace equipment, nuclear power control systems, vehicles, disaster/crime-prevention equipment and the like, the failure of which may directly or indirectly cause injury, death or property loss.
- Anyone purchasing any products described or contained herein for an above-mentioned use shall:
 - ① Accept full responsibility and indemnify and defend SANYO ELECTRIC CO., LTD., its affiliates, subsidiaries and distributors and all their officers and employees, jointly and severally, against any and all claims and litigation and all damages, cost and expenses associated with such use:
 - ② Not impose any responsibility for any fault or negligence which may be cited in any such claim or litigation on SANYO ELECTRIC CO., LTD., its affiliates, subsidiaries and distributors or any of their officers and employees jointly or severally.
- Information (including circuit diagrams and circuit parameters) herein is for example only; it is not guaranteed for volume production. SANYO believes information herein is accurate and reliable, but no guarantees are made or implied regarding its use or any infringements of intellectual property rights or other rights of third parties.

This catalog provides information as of November, 1997. Specifications and information herein are subject to change without notice.