



STK11C68-M

CMOS nvSRAM

High Performance

8K x 8 Nonvolatile Static RAM

MIL-STD-883/SMD # 5962-92324

FEATURES

- 35, 45 and 55ns Access Times
- 17, 20 and 25ns Output Enable Access
- Unlimited Read and Write to SRAM
- Software *STORE* Initiation
- Automatic *STORE* Timing
- 100,000 *STORE* cycles to EEPROM
- 10 year data retention in EEPROM
- Automatic *RECALL* on Power Up
- Software *RECALL* Initiation
- Unlimited *RECALL* cycles from EEPROM
- Single 5V \pm 10% Operation
- Available in multiple standard packages

DESCRIPTION

The Simtek STK11C68-M is a fast static RAM (35, 45 and 55ns), with a nonvolatile electrically-erasable PROM (EEPROM) element incorporated in each static memory cell. The SRAM can be read and written an unlimited number of times, while independent nonvolatile data resides in EEPROM. Data transfers from the SRAM to the EEPROM (*STORE*), or from the EEPROM to the SRAM (*RECALL*) are initiated through software sequences. It combines the high performance and ease of use of a fast SRAM with nonvolatile data integrity.

The STK11C68-M is pin compatible with industry standard SRAMs and is available in a 28-pin 300 mil ceramic DIP or 28-pad LCC package. Commercial and industrial devices are also available.

LOGIC BLOCK DIAGRAM

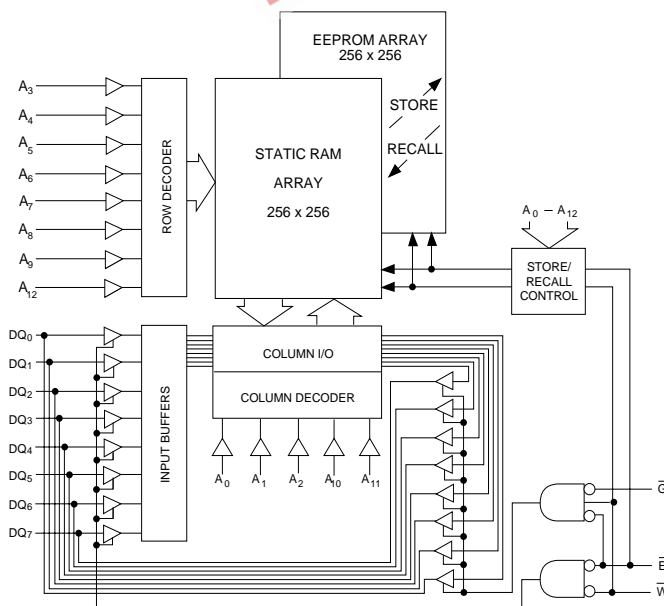

PIN CONFIGURATIONS

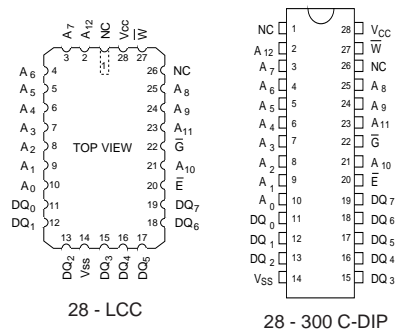

PIN NAMES

A ₀ - A ₁₂	Address Inputs
\bar{W}	Write Enable
DQ ₀ - DQ ₇	Data In/Out
\bar{E}	Chip Enable
\bar{G}	Output Enable
V _{CC}	Power (+5V)
V _{SS}	Ground

ABSOLUTE MAXIMUM RATINGS^a

Voltage on typical input relative to V_{SS} -0.6V to 7.0V
 Voltage on DQ_{0-7} and \bar{G} -0.5V to ($V_{CC}+0.5V$)
 Temperature under bias -55°C to 125°C
 Storage temperature. -65°C to 150°C
 Power dissipation. 1W
 DC output current 15mA
 (One output at a time, one second duration)

Note a: Stresses greater than those listed under "Absolute Maximum Ratings" may cause permanent damage to the device. This is a stress rating only, and functional operation of the device at conditions above those indicated in the operational sections of this specification is not implied. Exposure to absolute maximum rating conditions for extended periods may affect reliability.

DC CHARACTERISTICS

($V_{CC} = 5.0V \pm 10\%$)

SYMBOL	PARAMETER	MIN	MAX	UNITS	NOTES
I_{CC1}^b	Average V_{CC} Current		90	mA	$t_{AVAV} = 35ns$
			85	mA	$t_{AVAV} = 45ns$
			80	mA	$t_{AVAV} = 55ns$
I_{CC2}^d	Average V_{CC} Current during STORE cycle		50	mA	$\bar{E} \geq (V_{CC} - 0.2V)$ all others $V_{IN} \leq 0.2V$ or $\geq (V_{CC} - 0.2V)$
I_{SB1}^c	Average V_{CC} Current (Standby, Cycling TTL Input Levels)		27	mA	$t_{AVAV} = 35ns$
			23	mA	$t_{AVAV} = 45ns$
			20	mA	$t_{AVAV} = 55ns$ $\bar{E} \geq V_{IH}$; all others cycling
I_{SB2}^c	Average V_{CC} Current (Standby, Stable CMOS Input Levels)		2	mA	$\bar{E} \geq (V_{CC} - 0.2V)$ all others $V_{IN} \leq 0.2V$ or $\geq (V_{CC} - 0.2V)$
I_{ILK}	Input Leakage Current (Any Input)		± 1	μA	$V_{CC} = \max$ $V_{IN} = V_{SS}$ to V_{CC}
I_{OLK}	Off State Output Leakage Current		± 5	μA	$V_{CC} = \max$ $V_{IN} = V_{SS}$ to V_{CC}
V_{IH}	Input Logic "1" Voltage	2.2	$V_{CC}+0.5$	V	All Inputs
V_{IL}	Input Logic "0" Voltage	$V_{SS}-0.5$	0.8	V	All Inputs
V_{OH}	Output Logic "1" Voltage	2.4		V	$I_{OUT} = -4mA$
V_{OL}	Output Logic "0" Voltage		0.4	V	$I_{OUT} = 8mA$
T_A	Operating Temperature	-55	125	°C	

Note b: I_{CC1} is dependent on output loading and cycle rate. The specified values are obtained with outputs unloaded.
 Note c: Bringing $\bar{E} \geq V_{IH}$ will not produce standby current levels until any nonvolatile cycle in progress has timed out. See MODE SELECTION table.
 Note d: I_{CC2} is the average current required for the duration of the store cycle (t_{STORE}) after the sequence (t_{WC}) that initiates the cycle.

AC TEST CONDITIONS

Input Pulse Levels. V_{SS} to 3V
 Input Rise and Fall Times. $\leq 5ns$
 Input and Output Timing Reference Levels. 1.5V
 Output Load. See Figure 1

CAPACITANCE^e ($T_A=25^\circ C, f=1.0MHz$)

SYMBOL	PARAMETER	MAX	UNITS	CONDITIONS
C_{IN}	Input Capacitance	5	pF	$\Delta V = 0$ to 3V
C_{OUT}	Output Capacitance	7	pF	$\Delta V = 0$ to 3V

Note e: These parameters are guaranteed but not tested.

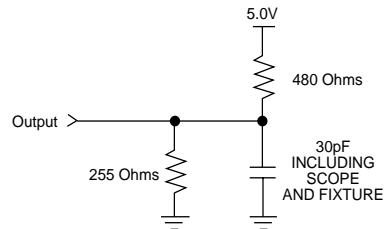

Figure 1: AC Output Loading

READ CYCLES #1 & #2

(V_{CC} = 5.0V ± 10%)

NO.	SYMBOLS		PARAMETER	STK11C68-35M		STK11C68-45M		STK11C68-55M		UNITS
	#1, #2	Alt.		MIN	MAX	MIN	MAX	MIN	MAX	
1	t _{ELQV}	t _{ACS}	Chip Enable Access Time		35		45		55	ns
2	t _{AVAV} ^g	t _{RC}	Read Cycle Time	35		45		55		ns
3	t _{AVQV} ^h	t _{AA}	Address Access Time		35		45		55	ns
4	t _{GLQV}	t _{OE}	Output Enable to Data Valid		20		25		25	ns
5	t _{AXQX}	t _{OH}	Output Hold After Address Change	5		5		5		ns
6	t _{ELQX}	t _{LZ}	Chip Enable to Output Active	5		5		5		ns
7	t _{EHQZ} ⁱ	t _{HZ}	Chip Disable to Output Inactive		17		20		25	ns
8	t _{GLQX}	t _{OLZ}	Output Enable to Output Active	0		0		0		ns
9	t _{GHQZ} ⁱ	t _{OHZ}	Output Disable to Output Inactive		17		20		25	ns
10	t _{ELICCH} ^e	t _{PA}	Chip Enable to Power Active	0		0		0		ns
11	t _{EHICCL} ^{c,e}	t _{PS}	Chip Disable to Power Standby		35		45		55	ns
11A	t _{WHQV}	t _{WR}	Write Recovery Time		45		55		65	ns

Note c: Bringing \bar{E} high will not produce standby currents until any nonvolatile cycle in progress has timed out. See MODE SELECTION table.

Note e: Parameter guaranteed but not tested.

Note g: For READ CYCLE #1 and #2, \bar{W} must be high for entire cycle.

Note h: Device is continuously selected with \bar{E} low and \bar{G} low.

Note i: Measured ± 200mV from steady state output voltage.

READ CYCLE #1 ^{g,h}

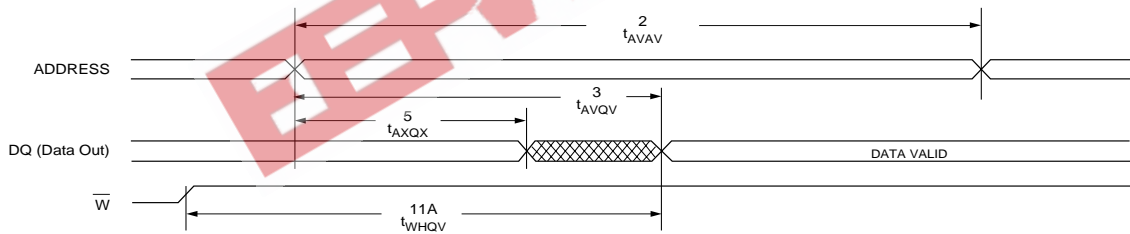

READ CYCLE #2 ^g

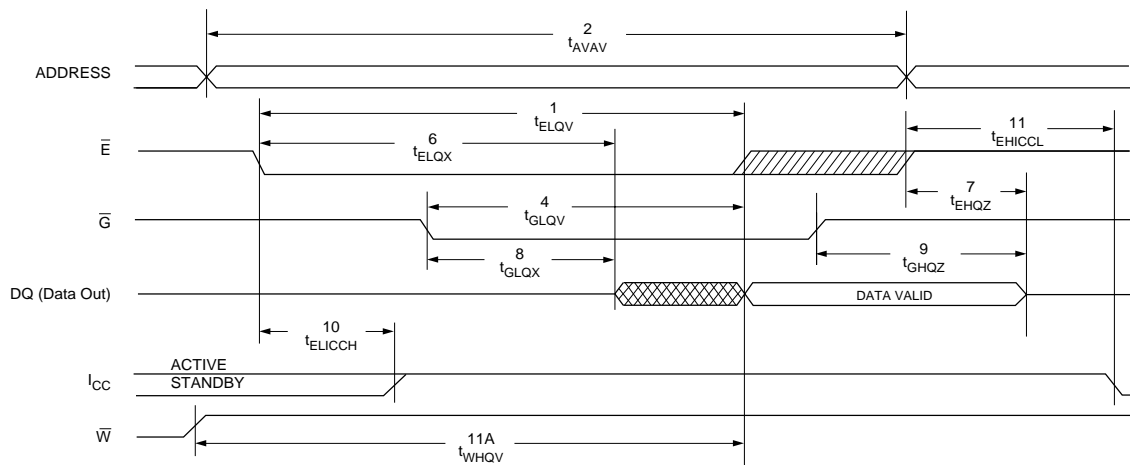

STK11C68-M

WRITE CYCLES #1 & #2; \bar{G} high

($V_{CC} = 5.0V \pm 10\%$)

NO.	SYMBOLS			PARAMETER	STK11C68-35M		STK11C68-45M		STK11C68-55M		UNITS
	#1	#2	Alt.		MIN	MAX	MIN	MAX	MIN	MAX	
12	t_{AVAV}	t_{AVAV}	t_{WC}	Write Cycle Time	35		45		55		ns
13	t_{WLWH}	t_{WLEH}	t_{WP}	Write Pulse Width	30		35		45		ns
14	t_{ELWH}	t_{ELEH}	t_{CW}	Chip Enable to End of Write	30		35		45		ns
15	t_{DVWH}	t_{DVEH}	t_{DW}	Data Set-up to End of Write	18		20		30		ns
16	t_{WHDX}	t_{EHDX}	t_{DH}	Data Hold After End of Write	0		0		0		ns
17	t_{AVWH}	t_{AVEH}	t_{AW}	Address Set-up to End of Write	30		35		45		ns
18	t_{AVWL}	t_{AVEL}	t_{AS}	Address Set-up to Start of Write	0		0		0		ns
19	t_{WHAX}	t_{EHAX}	t_{WR}	Address Hold After End of Write	0		0		0		ns

WRITE CYCLES #1 & #2; \bar{G} low

($V_{CC} = 5.0V \pm 10\%$)

NO.	SYMBOLS			PARAMETER	STK11C68-35M		STK11C68-45M		STK11C68-55M		UNITS
	#1	#2	Alt.		MIN	MAX	MIN	MAX	MIN	MAX	
12	t_{AVAV}	t_{AVAV}	t_{WC}	Write Cycle Time	45		45		55		ns
13	t_{WLWH}	t_{WLEH}	t_{WP}	Write Pulse Width	35		35		45		ns
14	t_{ELWH}	t_{ELEH}	t_{CW}	Chip Enable to End of Write	35		35		45		ns
15	t_{DVWH}	t_{DVEH}	t_{DW}	Data Set-up to End of Write	30		30		30		ns
16	t_{WHDX}	t_{EHDX}	t_{DH}	Data Hold After End of Write	0		0		0		ns
17	t_{AVWH}	t_{AVEH}	t_{AW}	Address Set-up to End of Write	35		35		45		ns
18	t_{AVWL}	t_{AVEL}	t_{AS}	Address Set-up to Start of Write	0		0		0		ns
19	t_{WHAX}	t_{EHAX}	t_{WR}	Address Hold After End of Write	0		0		0		ns
20	$t_{WLQZ}^{i,m}$		t_{WZ}	Write Enable to Output Disable		35		35		35	ns
21	t_{WHQX}		t_{OW}	Output Active After End of Write	5		5		5		ns

Note i: Measured $\pm 200mV$ from steady state output voltage.

Note k: \bar{E} or \bar{W} must be $\geq V_{IH}$ during address transitions.

Note m: If \bar{W} is low when \bar{E} goes low, the outputs remain in the high impedance state.

WRITE CYCLE #1: \bar{W} CONTROLLED^k

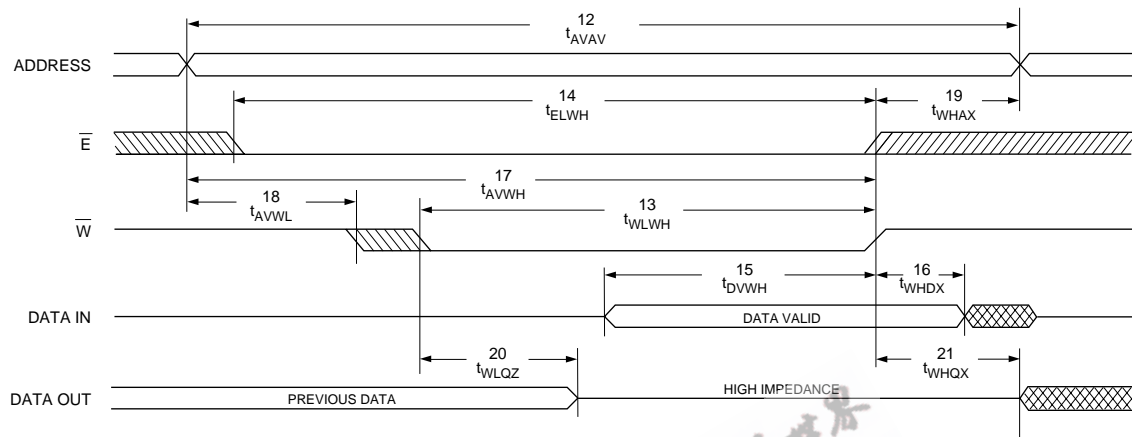

WRITE CYCLE #2: \bar{E} CONTROLLED^k

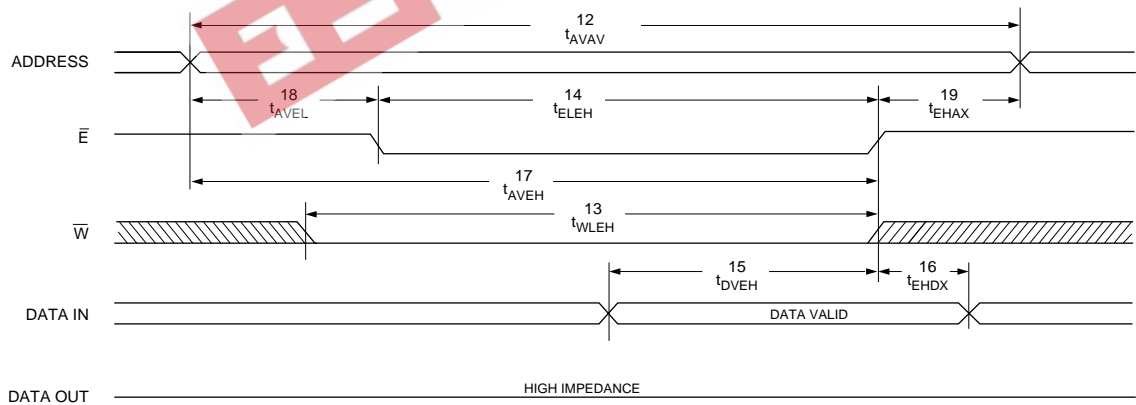

NONVOLATILE MEMORY OPERATION

MODE SELECTION

\bar{E}	\bar{W}	A ₁₂ - A ₀ (hex)	MODE	I/O	POWER	NOTES
H	X	X	Not Selected	Output High Z	Standby	
L	H	X	Read SRAM	Output Data	Active	o
L	L	X	Write SRAM	Input Data	Active	
L	H	0000	Read SRAM	Output Data	Active	n,o
		1555	Read SRAM	Output Data		n,o
		0AAA	Read SRAM	Output Data		n,o
		1FFF	Read SRAM	Output Data		n,o
		10F0	Read SRAM	Output Data		n,o
		0F0F	Nonvolatile <i>STORE</i>	Output High Z		I_{CC2}
L	H	0000	Read SRAM	Output Data	Active	n,o
		1555	Read SRAM	Output Data		n,o
		0AAA	Read SRAM	Output Data		n,o
		1FFF	Read SRAM	Output Data		n,o
		10F0	Read SRAM	Output Data		n,o
		0F0E	Nonvolatile <i>RECALL</i>	Output High Z		

Note n: The six consecutive addresses must be in order listed - (0000, 1555, 0AAA, 1FFF, 10F0, 0F0F) for a *STORE* cycle or (0000, 1555, 0AAA, 1FFF, 10F0, 0F0E) for a *RECALL* cycle. \bar{W} must be high during all six consecutive cycles. See *STORE* cycle and *RECALL* cycle tables and diagrams for further details.

Note o: I/O state assumes that $\bar{G} \leq V_{IL}$. Initiation and operation of nonvolatile cycles does not depend on the state of \bar{G} .

STORE CYCLE INHIBIT and AUTOMATIC POWER-UP RECALL

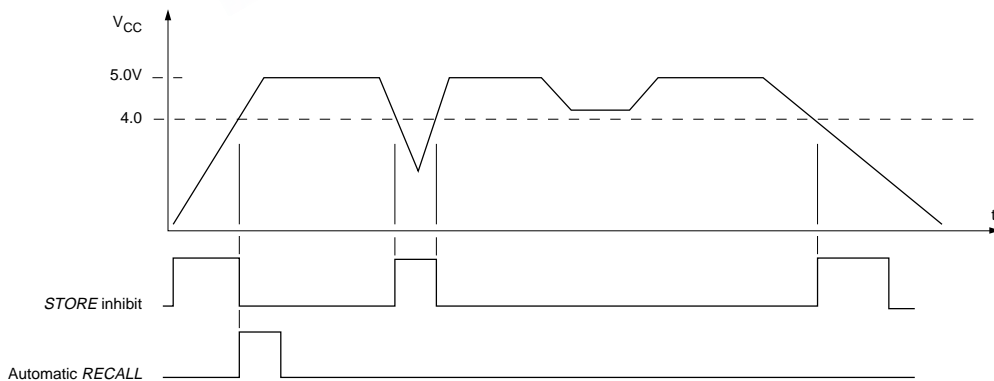

STORE/RECALL CYCLE

($V_{CC} = 5.0V \pm 10\%$)

NO.	SYMBOLS		PARAMETER	STK11C68-35M		STK11C68-45M		STK11C68-55M		UNITS
	#1	Alt.		MIN	MAX	MIN	MAX	MIN	MAX	
22	t_{AVAV}	t_{RC}	STORE/RECALL Initiation Cycle Time	35		45		55		ns
23	t_{ELQZ}^D		Chip Enable to Output Inactive		75		75		85	ns
24	t_{ELQXS}	t_{STORE}^Q	STORE Cycle Time		10		10		10	ms
25	t_{ELQXR}	t_{RECALL}^T	RECALL Cycle Time		20		20		20	μs
26	t_{AVELN}^S	t_{AE}	Address Set-up to Chip Enable	0		0		0		ns
27	$t_{ELEHN}^{S,t}$	t_{EP}	Chip Enable Pulse Width	25		35		45		ns
28	t_{EHAXN}^S	t_{EA}	Chip Disable to Address Change	0		0		0		ns

- Note p: Once the software STORE or RECALL cycle is initiated, it completes automatically, ignoring all inputs.
- Note q: Note that STORE cycles (but not RECALLs) are aborted by $V_{CC} < 4.0V$ (STORE inhibit).
- Note r: A RECALL cycle is initiated automatically at power up when V_{CC} exceeds 4.0V. t_{RECALL} is measured from the point at which V_{CC} exceeds 4.5V.
- Note s: Noise on the \bar{E} pin may trigger multiple read cycles from the same address and abort the address sequence.
- Note t: If the Chip Enable Pulse Width is less than t_{ELQV} (see READ CYCLE #2) but greater than or equal to t_{ELEHN} , then the data may not be valid at the end of the low pulse, however the STORE or RECALL will still be initiated.
- Note u: \bar{W} must be HIGH when \bar{E} is LOW during the address sequence in order to initiate a nonvolatile cycle. \bar{G} may be either HIGH or LOW throughout. Addresses #1 through #6 are found in the MODE SELECTION table. Address #6 determines whether the STK11C68-M performs a STORE or RECALL.
- Note v: \bar{E} must be used to clock in the address sequence for the Software STORE and RECALL cycles.

STORE/RECALL CYCLE ^{u,v}

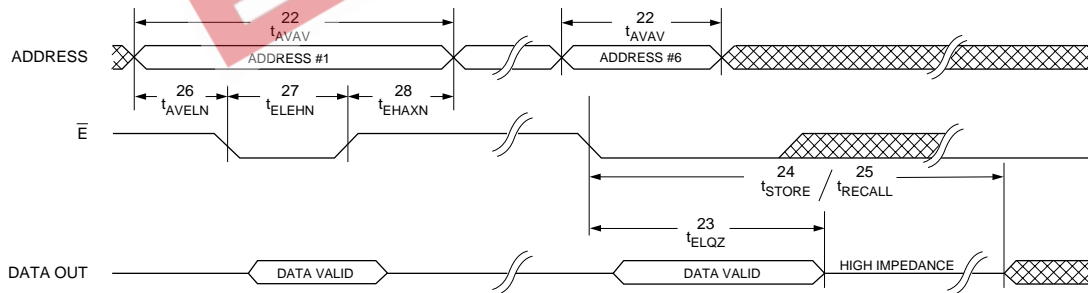

DEVICE OPERATION

The STK11C68-M has two separate modes of operation: SRAM mode and nonvolatile mode. In SRAM mode, the memory operates as an ordinary static RAM. In nonvolatile operation, data is transferred from SRAM to EEPROM or from EEPROM to SRAM. In this mode SRAM functions are disabled.

SRAM READ

The STK11C68-M performs a READ cycle whenever \bar{E} and \bar{G} are LOW while \bar{W} is HIGH. The address specified on pins A_{0-12} determines which of the 8192 data bytes will be accessed. When the READ is initiated by an address transition, the outputs will be valid after a delay of t_{AVQV} (READ CYCLE #1). If the READ is initiated by \bar{E} or \bar{G} , the outputs will be valid at t_{ELQV} or at t_{GLQV} , whichever is later (READ CYCLE #2). The data outputs will repeatedly respond to address changes within the t_{AVQV} access time without the need for transitions on any control input pins, and will remain valid until another address change or until \bar{E} or \bar{G} is brought HIGH or \bar{W} is brought LOW.

The STK11C68-M is a high speed memory and therefore must have a high frequency bypass capacitor of approximately 0.1 μ F connected between DUT V_{CC} and V_{SS} using leads and traces that are as short as possible. As with all high speed CMOS ICs, normal careful routing of power, ground and signals will help prevent noise problems.

SRAM WRITE

A write cycle is performed whenever \bar{E} and \bar{W} are LOW. The address inputs must be stable prior to entering the WRITE cycle and must remain stable until either \bar{E} or \bar{W} go HIGH at the end of the cycle. The data on pins DQ_{0-7} will be written into the memory if it is valid t_{DVWH} before the end of a \bar{W} controlled WRITE or t_{DVEH} before the end of an \bar{E} controlled WRITE.

It is recommended that \bar{G} be kept HIGH during the entire WRITE cycle to avoid data bus contention on common I/O lines. If \bar{G} is left LOW, internal circuitry will turn off the output buffers t_{WLQZ} after \bar{W} goes LOW.

NONVOLATILE STORE

The STK11C68-M STORE cycle is initiated by executing sequential READ cycles from six specific address locations. By relying on READ cycles only, the STK11C68-M implements nonvolatile operation while remaining pin-for-pin compatible with standard 8Kx8 SRAMs. During the STORE cycle, an erase of the

previous nonvolatile data is first performed, followed by a program of the nonvolatile elements. The program operation copies the SRAM data into nonvolatile elements. Once a STORE cycle is initiated, further input and output are disabled until the cycle is completed.

Because a sequence of reads from specific addresses is used for STORE initiation, it is important that no other read or write accesses intervene in the sequence or the sequence will be aborted and no STORE or RECALL will take place.

To initiate the STORE cycle the following READ sequence must be performed:

1.	Read address	0000 (hex)	Valid READ
2.	Read address	1555 (hex)	Valid READ
3.	Read address	0AAA (hex)	Valid READ
4.	Read address	1FFF (hex)	Valid READ
5.	Read address	10F0 (hex)	Valid READ
6.	Read address	0F0F (hex)	Initiate STORE Cycle

Once the sixth address in the sequence has been entered, the STORE cycle will commence and the chip will be disabled. It is important that READ cycles and not WRITE cycles be used in the sequence, although it is not necessary that \bar{G} be LOW for the sequence to be valid. After the t_{STORE} cycle time has been fulfilled, the SRAM will again be activated for READ and WRITE operation.

HARDWARE PROTECT

The STK11C68-M offers hardware protection against inadvertent STORE cycles through V_{CC} Sense. A STORE cycle will not be initiated, and one in progress will discontinue, if V_{CC} goes below 4.0V. 4.0V is a typical, characterized value. The datasheet specifications are guaranteed only for $V_{CC} = 5.0 \pm 10\%$.

NONVOLATILE RECALL

A RECALL cycle of the EEPROM data into the SRAM is initiated with a sequence of READ operations in a manner similar to the STORE initiation. To initiate the RECALL cycle the following sequence of READ operations must be performed:

1.	Read address	0000 (hex)	Valid READ
2.	Read address	1555 (hex)	Valid READ
3.	Read address	0AAA (hex)	Valid READ
4.	Read address	1FFF (hex)	Valid READ
5.	Read address	10F0 (hex)	Valid READ
6.	Read address	0F0E (hex)	Initiate RECALL Cycle

Internally, *RECALL* is a two step procedure. First, the SRAM data is cleared and second, the nonvolatile information is transferred into the SRAM cells. The *RECALL* operation in no way alters the data in the EEPROM cells. The nonvolatile data can be recalled an unlimited number of times.

On power-up, once V_{CC} exceeds the V_{CC} sense voltage of 4.0V, a *RECALL* cycle is automatically initiated. The voltage on the V_{CC} pin must not drop below 4.0V

once it has risen above it in order for the *RECALL* to operate properly. Due to this automatic *RECALL*, SRAM operation cannot commence until t_{RECALL} after V_{CC} exceeds 4.0V. 4.0V is a typical, characterized value.

If the STK11C68-M is in a WRITE state at the end of power-up *RECALL*, the SRAM data will be corrupted. To help avoid this situation, a 10K Ohm resistor should be connected between \bar{W} and system V_{CC} .

EEPW 电子产品世界
.com.cn

ORDERING INFORMATION

STK11C68 - 5 C 35 M

Temperature Range

M = Military (-55 to 125 degrees C)

Access Time

35 = 35ns

45 = 45ns

55 = 55ns

Package

G = Ceramic 28 pin 300-mil DIP with gold lead finish

K = Ceramic 28 pin 300-mil DIP with solder DIP finish

L = Ceramic 28 pin LCC

Retention / Endurance

10 years / 100,000 cycles

5962-92324 04 MX X

Lead Finish

A = Solder DIP lead finish

C = Gold lead DIP finish

X = lead finish "A" or "C" is acceptable

Package

MX = Ceramic 28 pin 300-mil DIP

MY = Ceramic 28 pin LCC

Access Time

04 = 55ns

05 = 45ns

06 = 35ns