

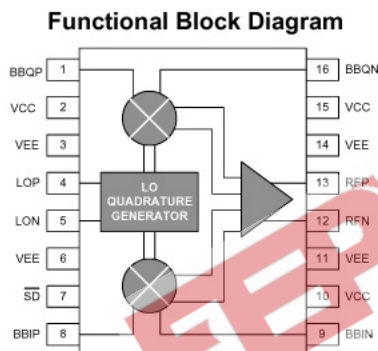

Product Description

The Sirenza Microdevices' STQ-3016 is a direct quadrature modulator targeted for use in a wide range of communications systems. This device features a wide 2500-4000 MHz operating frequency band, excellent carrier and sideband suppression, and a low broadband noise floor.

The STQ-3016 uses silicon germanium (SiGe) device technology and delivers a typical output power of -12dBm with greater than 50dB IM3 suppression. The device is packaged in an industry standard 16 pin TSSOP with exposed paddle for superb RF and thermal ground.



Product Specifications – RF Output: $T_A = 25^\circ\text{C}$

Parameters	Test Conditions: see page 2	Units	Min.	Typ.	Max.	Min.	Typ.	Max.
RF Frequency Range		MHz	2500		3000	3000		4000
Output Power		dBm	-14.0	-11.0	-10.0	-15.0	-12.0	-10.0
RF Port Return Loss	matched to 50Ω (refer to schematics on pages 6 & 7)	dB		15			10	
Output P1dB		dBm	-1	2.0		-1	2.0	
Carrier Feedthrough		dB		-42	-32		-42	-32
Sideband Suppression		dBm	30	36		28	33	
IM3 Suppression	two-tone baseband input @ 600mVp-p differential per tone	dB	50	55		50	55	
Broadband Noise Floor	baseband inputs tied to 1.9V _{DC} , -20MHz offset from carrier	dBm/Hz		-154			-153	
Quadrature Phase Error		deg	-4	±2.0	+4	-4	±2.5	+4
I/Q Amplitude Balance		dB	-0.2	±0.1	+0.2	-0.2	±0.1	+0.2
Supply Voltage (Vcc)		V	+4.75	+5	+5.25	+4.75	+5	+5.25
Supply Current		mA		80	88		80	88
Device Thermal Resistance	junction-case	°C/W		25			25	

The information provided herein is believed to be reliable at press time. Sirenza Microdevices assumes no responsibility for inaccuracies or omissions. Sirenza Microdevices assumes no responsibility for the use of this information, and all such information shall be entirely at the user's own risk. Prices and specifications are subject to change without notice. No patent rights or licenses to any of the circuits described herein are implied or granted to any third party. Sirenza Microdevices does not authorize or warrant any Sirenza Microdevices product for use in life-support devices and/or systems.
Copyright 2001 Sirenza Microdevices, Inc. All worldwide rights reserved.
303 S. Technology Court, Broomfield, CO 80021

Phone: (303) 327-3030

<http://www.sirenza.com>

Preliminary

STQ-3016

STQ-3016Z

2500 - 4000 MHz
Direct Quadrature Modulator



16 pin TSSOP with Exposed Ground Pad

Package Footprint: 0.197 x 0.252 inches, (5.0 x 6.4 mm)

Package Height: 0.039 inches (1.0 mm)

Product Features

- Excellent carrier feedthrough, -40 dBm
- Wide baseband input, DC - 500 MHz
- Superb phase accuracy and amplitude balance, $\pm 4^\circ/\pm 0.2$ dB
- No external IF filter required
- Very low noise floor, -153 dBm/Hz
- Low LO drive requirement, -6 dBm
- Single +5V supply with digital shut-down

Applications

- 2.5 and 3.5 GHz fixed wireless communication systems
- GMSK, QPSK, QAM, SSB modulators



Preliminary

STQ-3016 Direct Quadrature Modulator

Test Conditions

(for all product specification tables unless otherwise noted)

V _{CC} (pins 2, 10, 15)	+5V
T _A	+25°C
Baseband Input (Pins 1, 8, 9, 16)	1.9V DC bias, 200kHz frequency, 300mVp-p per pin = 600mVp-p differential drive, I and Q signals in quadrature
LO Input (Pins 4, 5)	-6dBm @ 3500 MHz

Product Specifications - Baseband Modulation Input: T_A = 25°C

Parameters	Additional Test Conditions	Unit	Min.	Typ.	Max.
Baseband Frequency Input	-3dB bandwidth, baseband inputs terminated in 50 ohms	MHz	DC		500
Baseband Input Resistance	per pin	kohms		4.4	
Baseband Input Capacitance	per pin	pF		0.5	

Product Specifications - LO Input: T_A = 25°C

Parameters	Additional Test Conditions	Unit	Min.	Typ.	Max.
Usable LO Frequency		MHz	2500		4000
LO Drive Level		dBm	-9	-6	-3
LO Port Return Loss	matched to 50Ω (refer to schematics on pages 6 & 7)	dB		16	

Product Specifications – Miscellaneous: T_A = 25°C

Parameters	Additional Test Conditions	Unit	Min.	Typ.	Max.
Shut-Down Attenuation		dB		60	
Shut-Down Pin Resistance	@ 1MHz	kohm		6.1	
Shut-Down Pin Capacitance	@ 1MHz	pF		0.7	
Shut-Down Control Voltage Thresholds	Shut-down disabled (normal operation)	V	4.0		V _{CC}
	Shut-down enabled	V	0.0		1.0
Shut-Down Settling Time		ns		<450	



Preliminary
STQ-3016 Direct Quadrature Modulator

2500 - 3000 MHz Typical Device Performance

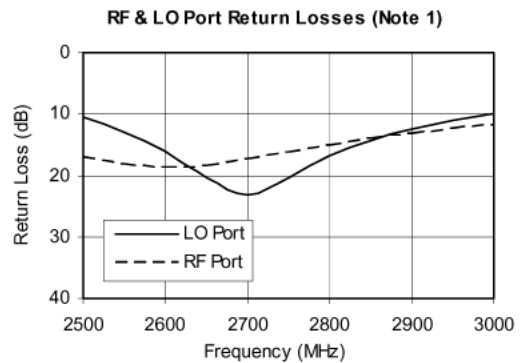
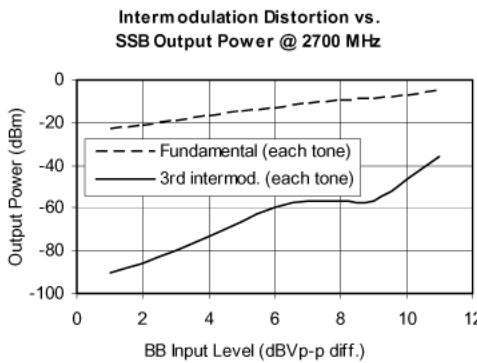
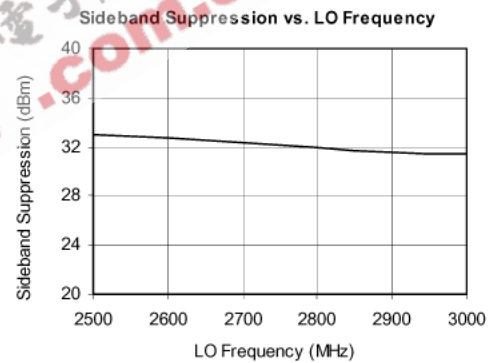
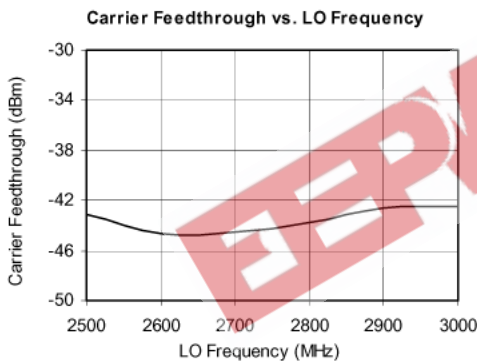
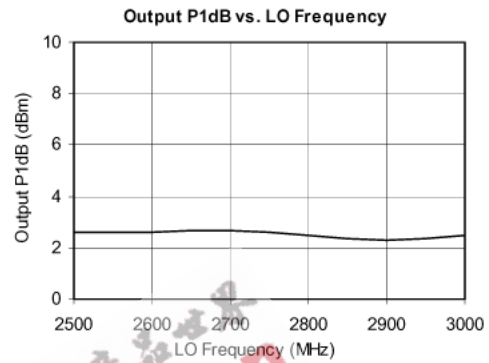
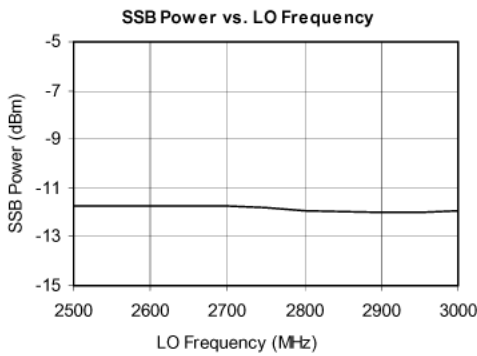

Note 1:
 The return losses shown were measured with the STQ-3016 mounted on our FR4 evaluation boards using standard matching practices as indicated on the application schematic page (6) herein. Users following the RF, LO and IF matching guidelines will achieve similar performance.



Preliminary
STQ-3016 Direct Quadrature Modulator

3000 - 4000 MHz Typical Device Performance

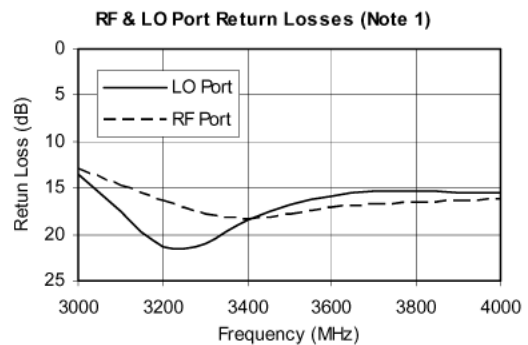
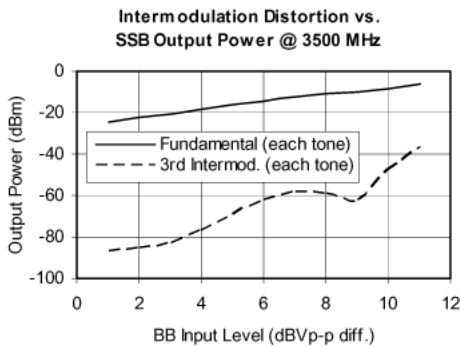
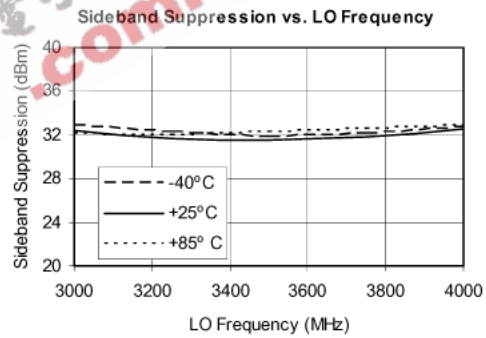
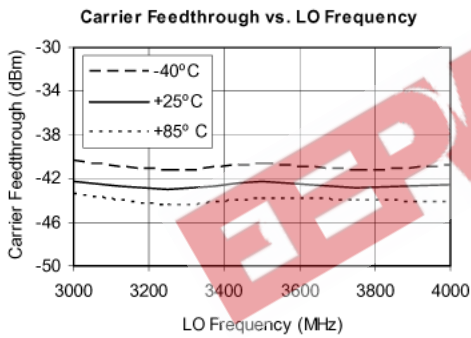
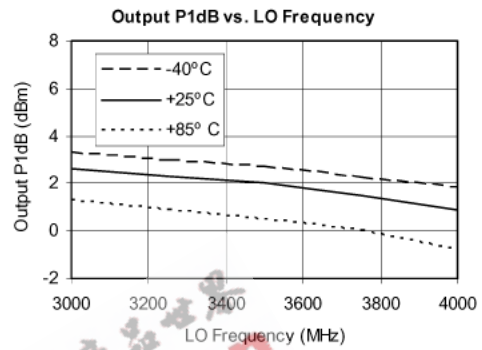
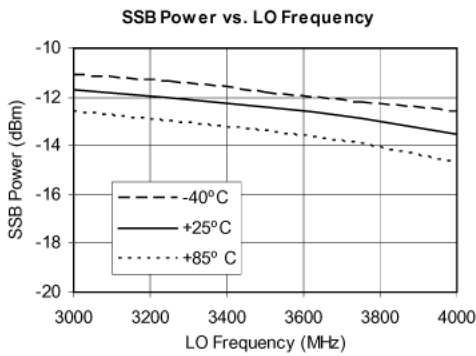

Note 1:

The return losses shown were measured with the STQ-3016 mounted on our FR4 evaluation boards using standard matching practices as indicated on the application schematic page (7) herein. Users following the RF, LO and IF matching guidelines will achieve similar performance.



Preliminary

STQ-3016 Direct Quadrature Modulator

Package Dimensions ("16" Package)

Dimensions in inches (mm)

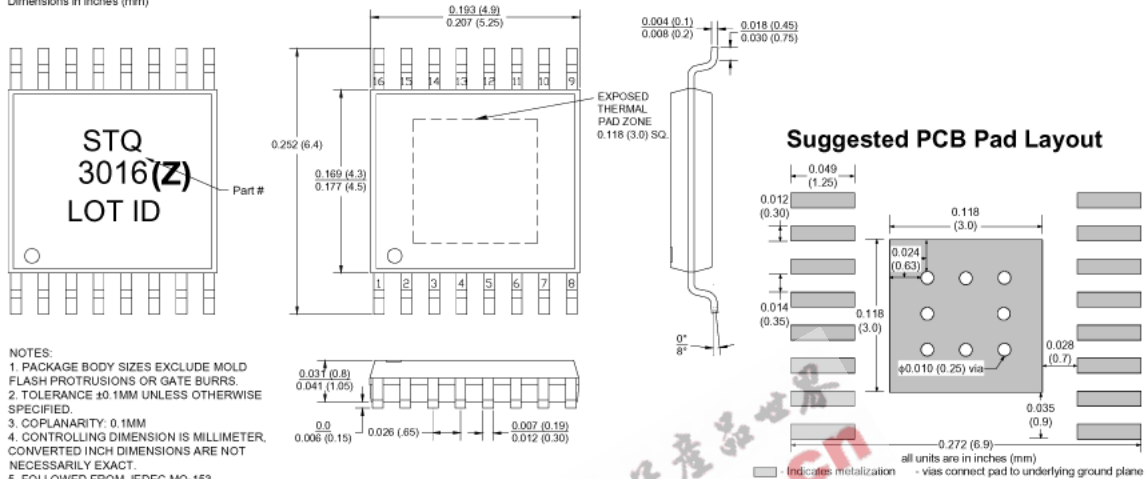

Pin Out Description

Pin #	Function	Description	Additional Comments
1	BBQP	Q-channel baseband input, positive terminal	Nominal DC bias voltage is 1.9V (biased internally)
2	VCC	Positive supply (+5V)	
3	VEE	Ground	
4	LOP	Local oscillator input, positive terminal	Nominal DC voltage is 2.0V. Input should be AC-coupled.
5	LON	Local oscillator input, negative terminal	Nominal DC voltage is 2.0V. Input should be AC-coupled.
6	VEE	Ground	
7	SD	Shut-down control	Logic high = normal operation; logic low = shut-down enabled.
8	BBIP	I-channel baseband input, positive terminal	Nominal DC bias voltage is 1.9V (biased internally)
9	BBIN	I-channel baseband input, negative terminal	Nominal DC bias voltage is 1.9V (biased internally)
10	VCC	Positive supply (+5V)	
11	VEE	Ground	
12	RFN	RF output, negative terminal	Nominal DC voltage is 2.4V. Output should be AC-coupled.
13	RFP	RF output, positive terminal	Nominal DC voltage is 2.4V. Output should be AC-coupled.
14	VEE	Ground	
15	VCC	Positive supply (+5V)	
16	BBQN	Q-channel baseband input, negative terminal	Nominal DC bias voltage is 1.9V (biased internally)

Absolute Maximum Ratings

Parameters	Value	Unit
Supply Voltage (VCC)	6.0	V _{DC}
LO, Input (LOP, LON, RFP, RFN)	+10	dBm
Baseband Min Input Voltage (BBIP, BBIN, BBQP, BBQN)	0	V _{DC}
Baseband Max Input Voltage (BBIP, BBIN, BBQP, BBQN)	3	V _{DC}
Operating Temperature	-40 to +85	°C
Storage Temperature	-65 to +150	°C

Operation of this device beyond any one of these limits may cause permanent damage. For reliable continuous operation the device voltage and current must not exceed the maximum operating values specified in the table on page one.

Part Number Ordering Information

Part Number	Reel Size	Standard Number of
		Devices per Reel
STQ-3016	7"	1000
STQ-3016Z	7"	1000

Moisture Sensitivity Level 1 - no special handling required



Caution: ESD Sensitive

Appropriate precaution in handling, packaging and testing devices must be observed.

2500 – 3250 MHz Application Schematic

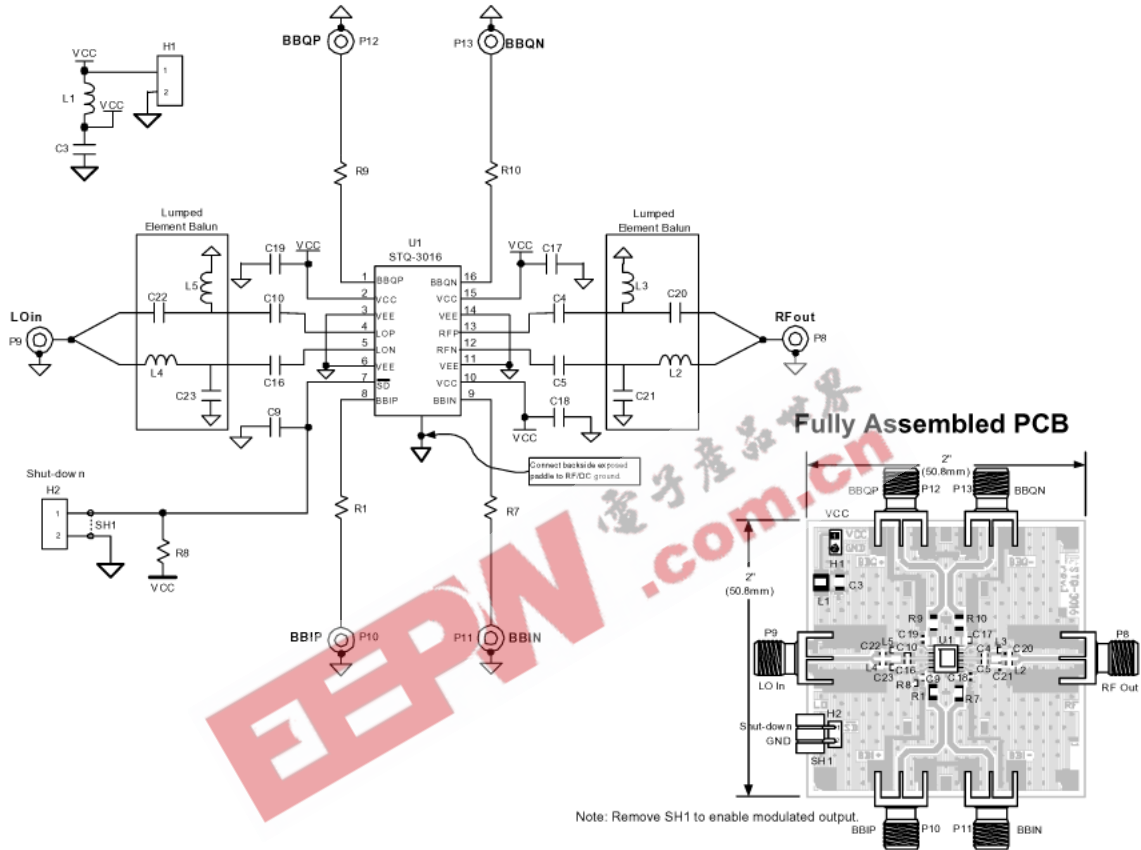

Bill of Materials (for 2500 - 3250 MHz Evaluation Board P/N EEB-102364)

Component Designator	Value	Qty	Vendor	Part Number	Description
U1		1	SMDI	STQ-3016	SiGe Direct Quadrature Modulator
P8, P9, P10, P11, P12, P13		6	Johnson Components	142-0701-851	SMA connector, end launch with tab, for .062" thick board
H1, H2		2	AMP	640453-2	2-pin header, right angle
L1	1uH	1	Panasonic	ELJ-FA1R0KF2	Inductor, 1210 footprint, ±10% tolerance
R1, R7, R9, R10	200 ohm	4	Venkel	CR1206-8W-2000FT	Resistor, 1206 footprint, ±1% tolerance
R8	10 kohm	1	Venkel	CR0603-16W-1002FT	Resistor, 0603 footprint, ±1% tolerance
C9, C17	1nF	2	Venkel	C0603COG500-102JNE	Capacitor, 0603 footprint, COG dielectric, ±5% tolerance
C3	2.2uF	1	Venkel	C1206Y5V160-225ZNE	Capacitor, 1206 footprint, Y5V dielectric, 16V rating
C4, C5, C18	1.0pF	6	Venkel	C0603COG500-1R0CNE	Capacitor, 0603 footprint, COG dielectric, ±0.25pF tolerance
SH1		1	3M	929950-00	Shunt for 2-pin header
L2, L3, L4, L5	3.3nH	4	TOKO	LL1608FS-3N3S	Inductor, 1608 footprint, ±0.3nH tolerance
C10, C16, C19, C20, C21, C22, C23	1.2pF	6	Venkel	C0603COG500-1R2CNE	Capacitor, 0603 footprint, COG dielectric, ±0.25pF tolerance

3250 – 4000 MHz Application Schematic

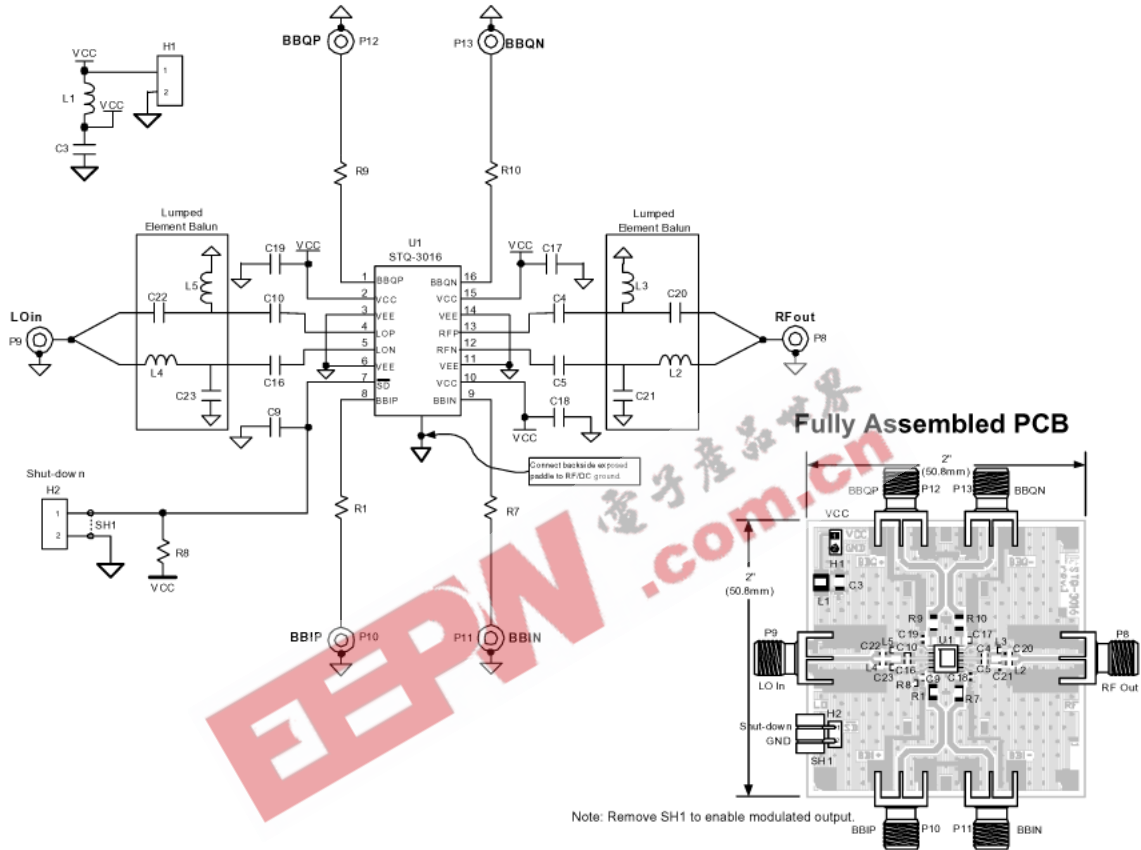

Bill of Materials (for 3250-4000 MHz Evaluation Board P/N EEB-102165)

Component Designator	Value	Qty	Vendor	Part Number	Description
U1		1	SMDI	STQ-3016	SiGe Direct Quadrature Modulator
P8, P9, P10, P11, P12, P13		6	Johnson Components	142-0701-851	SMA connector, end launch with tab, for .062" thick board
H1, H2		2	AMP	640453-2	2-pin header, right angle
L1	1uH	1	Panasonic	ELJ-FA1R0KF2	Inductor, 1210 footprint, ±10% tolerance
R1, R7, R9, R10	200 ohm	4	Venkel	CR1206-8W-2000FT	Resistor, 1206 footprint, ±1% tolerance
R8	10 kohm	1	Venkel	CR0603-16W-1002FT	Resistor, 0603 footprint, ±1% tolerance
C9, C17	1nF	2	Venkel	C0603COG500-102JNE	Capacitor, 0603 footprint, COG dielectric, ±5% tolerance
C3	2.2uF	1	Venkel	C1206Y5V160-225ZNE	Capacitor, 1206 footprint, Y5V dielectric, 16V rating
C4, C5, C18, C20, C21, C22, C23	1.0pF	6	Venkel	C0603COG500-1R0CNE	Capacitor, 0603 footprint, COG dielectric, ±0.25pF tolerance
SH1		1	3M	929950-00	Shunt for 2-pin header
L2, L3, L4, L5	2.2nH	4	TOKO	LL1608FS-2N2S	Inductor, 0603 footprint, ±0.3nH tolerance
C10, C16, C19	0.5pF	4	Venkel	C0603COG500-0R5CNE	Capacitor, 0603 footprint, COG dielectric, ±0.25pF tolerance

Direct Quadrature Modulator: General Test Set-Up

