



Product Description

The Sirenza Microdevices' STQ-1016 is a direct quadrature modulator targeted for use in a wide range of communications systems, including cellular/PCS, GSM, CDMA, TETRA, and ISM datacom. This device features a wide 250 - 1000 MHz operating frequency band, excellent carrier and sideband suppression, and a low broadband noise floor.

The STQ-1016 uses silicon germanium (SiGe) device technology and delivers a typical output power of -9 dBm with greater than 60dB IM3 suppression. A digital input shut-down feature is included that, when enabled, attenuates the output by 60dB. The device is packaged in an industry standard 16 pin TSSOP with exposed paddle for superb RF and thermal ground.

The matte tin finish on Sirenza's lead-free package utilizes a post annealing process to mitigate tin whisker formation and is RoHS compliant per EU directive 2002/95. This package is also manufactured with green molding compounds that contain no antimony trioxide nor halogenated fire retardants.

Functional Block Diagram

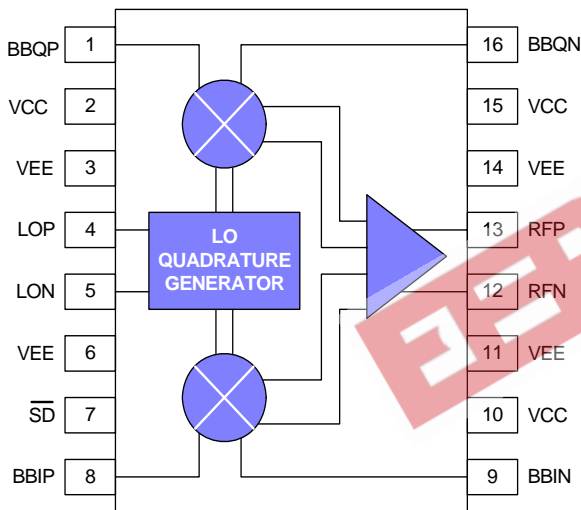

Product Specifications – RF Output: $T_A = 25^\circ\text{C}$

Parameters	Test Conditions (see page 2)	Units	Min.	Typ.	Max.
RF Frequency Range		MHz	250		1000
Output Power	(baseband input level 600 mVp-p differential)	dBm	-12.0	-9	-7
RF Port Return Loss	matched to 50Ω using schematic shown on page 5	dB		>10, 250 to 1000 MHz >15, 275 to 500 MHz	
Output P1dB	(baseband input level 3.8Vp-p differential typical)	dBm	+3	+6	
Carrier Feedthrough		dBm		-38	-30
Sideband Suppression		dB	34	42	
IM3 Suppression	2-tone BB input @ 600mVp-p diff. per tone, 20kHz spacing	dB	58	62	
Broadband Noise Floor	baseband inputs tied to 1.9V _{DC} , -20MHz offset from carrier	dBm/Hz		-154	-150*
Quadrature Phase Error		deg	-2	±0.5	+2
I/Q Amplitude Balance		dB	-0.2	±0.05	+0.2
Supply Voltage (Vcc)		V	+4.75	+5	+5.25
Supply Current		mA		80	86
Device Thermal Resistance	junction-case	°C/W		25	

*Guaranteed by design

Performance tests and ratings for Sirenza Microdevices' products were performed internally by Sirenza and measured using specific computer systems and/or components and reflect the approximate performance of the products as measured by those tests. Any difference in circuit implementation, test software, or test equipment may affect actual performance. The information provided herein is believed to be reliable at press time and Sirenza Microdevices assumes no responsibility for the use of this information. All such use shall be entirely at the user's own risk. Prices and specifications for Sirenza Microdevices' products are subject to change without notice. Buyers should consult Sirenza Microdevices' standard terms and conditions of sale for Sirenza's limited warranty with regard to its products. No patent rights or licenses to any of the circuits described herein are implied or granted to any third party. Sirenza Microdevices does not authorize or warrant any product for use in life-support devices and/or systems. Copyright 2004 Sirenza Microdevices, Inc. All worldwide rights reserved.

STQ-1016

STQ-1016Z



250 - 1000 MHz

Direct Quadrature Modulator



16 pin TSSOP with Exposed Ground Pad

Package Footprint: 0.197 x 0.252 inches, (5.0 x 6.4 mm)
Package Height: 0.039 inches (1.0 mm)

Product Features

- Available in Lead Free, RoHS compliant, and Green packaging
- Excellent carrier feedthrough, -38 dBm constant over output power
- Output P1dB +5dBm
- Very low noise floor, -154 dBm/Hz typical
- Wide baseband input, DC - 500 MHz
- Superb phase accuracy and amplitude balance, ±0.5 deg./±0.2 dB
- Low LO drive requirement, -5 dBm

Applications

- Cellular/PCS/GSM/CDMA transceivers
- TETRA
- GMSK, QPSK, QAM, SSB modulators

Test Conditions

(for all product specification tables unless otherwise noted)

V _{CC} (pins 2,10,15)	+5V
T _A	+25°C
Baseband Input (Pins 1, 8, 9, 16)	1.9V DC bias, 200kHz frequency, 300mVp-p per pin = 600mVp-p differential drive, I and Q signals in quadrature
LO Input (Pins 4, 5)	-5dBm @ 250 to 1000 MHz

Product Specifications - Baseband Modulation Input: T_A = 25°C

Parameters	Additional Test Conditions	Unit	Min.	Typ.	Max.
Baseband Frequency Input	-3dB bandwidth, baseband inputs terminated in 50 ohms	MHz	DC		500
Baseband Input Resistance	per pin	kohms		4.4	
Baseband Input Capacitance	per pin	pF		0.5	

Product Specifications - LO Input: T_A = 25°C

Parameters	Additional Test Conditions	Unit	Min.	Typ.	Max.
LO Frequency		MHz	250		1000
LO Drive Level		dBm	-8	-5	-2
LO Port Return Loss	matched to 50Ω using schematic shown on page 5	dB		>10, 250 to 1000 MHz >15, 275 to 500 MHz	

Product Specifications – Miscellaneous: T_A = 25°C

Parameters	Additional Test Conditions	Unit	Min.	Typ.	Max.
Shut-Down Supply Current	Shut-down enabled	mA		45	60
Shut-Down Attenuation		dB		60	
Shut-Down Pin Resistance	@ 1MHz	kohm		11.9	
Shut-Down Pin Capacitance	@ 1MHz	pF		5.2	
Shut-down Control Voltage Thresholds	Shut-down disabled (normal operation)	V	3.75		V _{CC}
	Shut-down enabled	V	0.0		1.5
Shut-Down Settling Time		ns		<450	

250 - 1000 MHz Typical Device Performance

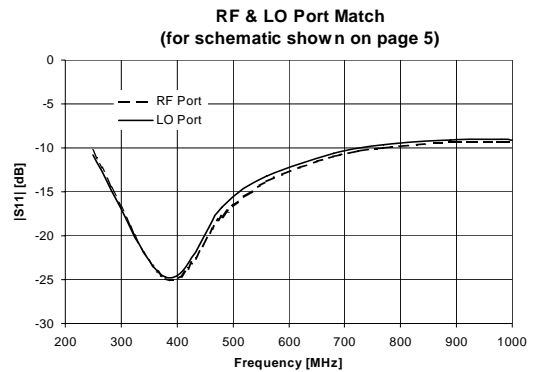
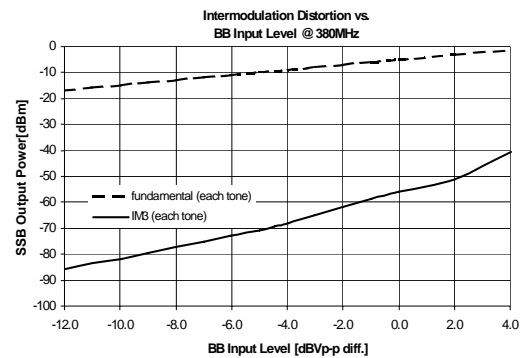
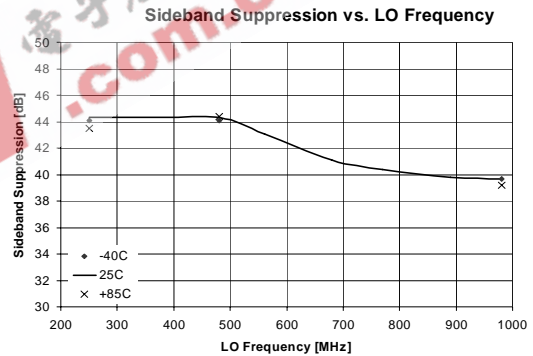
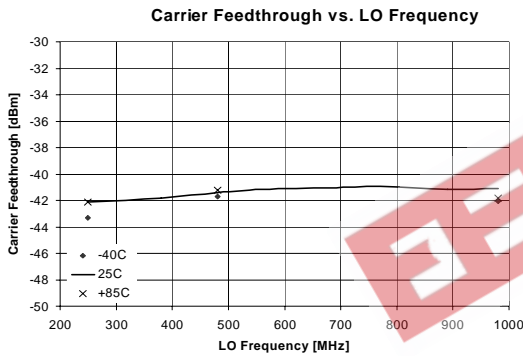
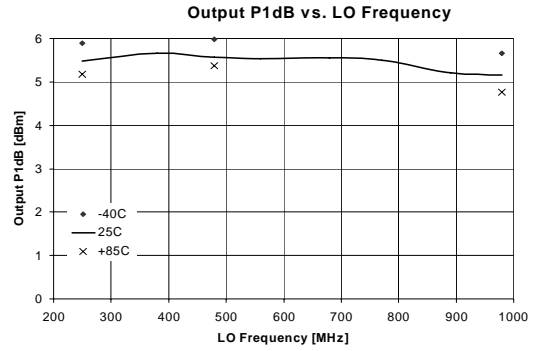
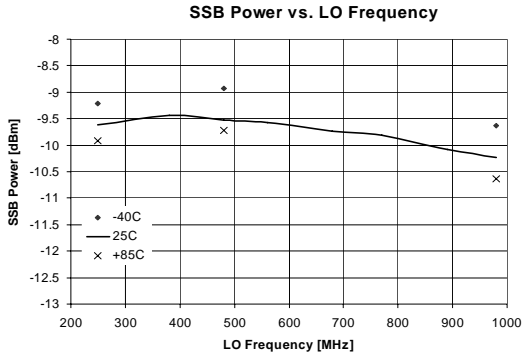

Package Dimensions ("16" Package)

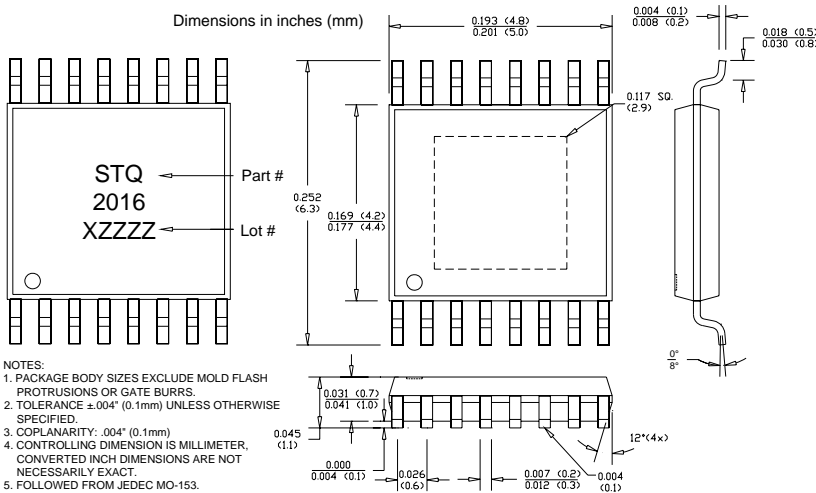

Suggested PCB Pad Layout

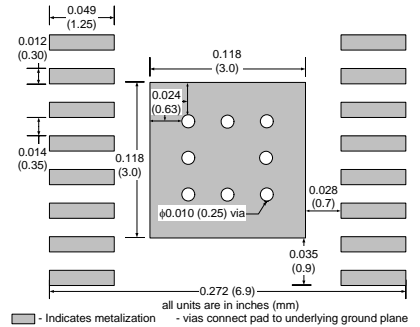

Pin Out Description

Pin #	Function	Description	Additional Comments
1	BBQP	Q-channel baseband input, positive terminal	Nominal DC bias voltage is 1.9V (biased internally)
2	VCC	Positive supply (+5V)	
3	VEE	Ground	
4	LOP	Local oscillator input, positive terminal	Nominal DC voltage is 2.0V. Input should be AC-coupled.
5	LON	Local oscillator input, negative terminal	Nominal DC voltage is 2.0V. Input should be AC-coupled.
6	VEE	Ground	
7	SD	Shut-down control	Logic high = normal operation; logic low = shut-down enabled.
8	BBIP	I-channel baseband input, positive terminal	Nominal DC bias voltage is 1.9V (biased internally)
9	BBIN	I-channel baseband input, negative terminal	Nominal DC bias voltage is 1.9V (biased internally)
10	VCC	Positive supply (+5V)	
11	VEE	Ground	
12	RFN	RF output, negative terminal	Nominal DC voltage is 2.4V. Output should be AC-coupled.
13	RFP	RF output, positive terminal	Nominal DC voltage is 2.4V. Output should be AC-coupled.
14	VEE	Ground	
15	VCC	Positive supply (+5V)	
16	BBQN	Q-channel baseband input, negative terminal	Nominal DC bias voltage is 1.9V (biased internally)

Absolute Maximum Ratings

Parameters	Value	Unit
Supply Voltage (VCC)	6.0	V _{DC}
LO, RF Input (LOP, LON, RFP, RFN)	+10	dBm
Baseband Min Input Voltage (BBIP, BBIN, BBQP, BBQN)	0	V _{DC}
Baseband Max Input Voltage (BBIP, BBIN, BBQP, BBQN)	3	V _{DC}
Operating Temperature	-40 to +85	°C
Storage Temperature	-65 to +150	°C

Operation of this device beyond any one of these limits may cause permanent damage. For reliable continuous operation the device voltage and current must not exceed the maximum operating values specified in the table on page one.

Part Number Ordering Information

Part Number	Reel Size	Devices/Reel
STQ-1016	7"	1000
STQ-1016Z	7"	1000

Moisture Sensitivity Level 1 - no special handling required.



Caution: ESD Sensitive

Appropriate precaution in handling, packaging and testing devices must be observed.

Direct Quadrature Modulator: General Test Set-Up

