

MODEL T SERIES

Thick Film

Super Low Profile SIP

Resistor Networks



ELECTRICAL

Standard Resistance Range, Ohms	22 to 1Meg
Standard Resistance Tolerance, at 25°C	±5% (J Tol.) Optional: ±2% (G Tol.)
Operating Temperature Range	-55°C to +125°C
Temperature Coefficient of Resistance	±200ppm/°C
Temperature Coefficient of Resistance Tracking	±50ppm/°C
Maximum Operating Voltage	50Vdc or \sqrt{PR}
Insulation Resistance	≥10,000 Megohms

4

MECHANICAL

Lead Material	Steel Alloy
Lead Finish	Solder (90/10 Typical)
Substrate Material	96% Alumina
Resistor Material	Cermet
Body Material	Conformal Epoxy Resin

ENVIRONMENTAL (PER MIL-R 83401, REV. D)

Thermal Shock	ΔR ±0.50%
Short Time Overload	ΔR ±0.50%
Terminal Strength	ΔR ±0.25%
Moisture Resistance	ΔR ±0.50%
Mechanical Shock	ΔR ±0.25%
Vibration Shock	ΔR ±0.25%
Low Temperature Storage	ΔR ±0.25%
High Temperature Exposure	ΔR ±0.50%
Load Life, 1,000 Hours	ΔR ±2.00%
Resistance to Solder Heat (Per MIL-STD-202, Method 210, Cond.B)	ΔR ±0.25%
Storage Temperature Range	-55°C to +125°C

Specifications subject to change without notice.

APPLICABLE DOCUMENTS

- MIL-R-83401 — Resistor Networks, Fixed, Film, General Specifications
 MIL-STD-105 — Sampling Procedures and Tables for Inspection by Attributes
 MIL-STD-202 — Test Methods for Electronic and Electrical Component Parts

STANDARD RESISTANCE VALUES, OHMS

-3 Circuit (Isolated Resistors) & -1 Circuit (Bussed Resistors)					
Ohms	Code	Ohms	Code	Ohms	Code
22	220	1K	102	27K	273
33	330	1.2K	122	33K	333
39	390	1.5K	152	39K	393
47	470	1.8K	182	47K	473
56	560	2K	202	56K	563
68	680	2.2K	222	68K	683
82	820	2.7K	272	82K	823
100	101	3.3K	332	100K	104
120	121	3.9K	392	120K	124
150	151	4.7K	472	150K	154
180	181	5.6K	562	180K	184
220	221	6.8K	682	220K	224
270	271	8.2K	822	270K	274
330	331	10K	103	330K	334
390	391	12K	123	390K	394
470	471	15K	153	470K	474
560	561	18K	183	560K	564
680	681	20K	203	680K	684
820	821	22K	223	820K	824
				1Meg	105
-5 Circuit (Dual Terminators)					
Ohms	Code	Ohms	Code	Ohms	Code
R1/R2	R1/R2	R1/R2	R1/R2	R1/R2	R1/R2
180/390	181/391	330/390	331/391	3K/6.2K	302/622
220/270	221/271	330/470	331/471		
220/330	221/331	330/680	331/681		

POWER DISSIPATION, AT 70°C

Model	Per Package	Per Resistor
Tn-1	$(n-1) \times 0.100$	0.100
Tn-3	$(n-1) \times 0.100$	0.100
Tn-5	$(n-1) \times 0.100$	0.060

POWER DERATING CURVE

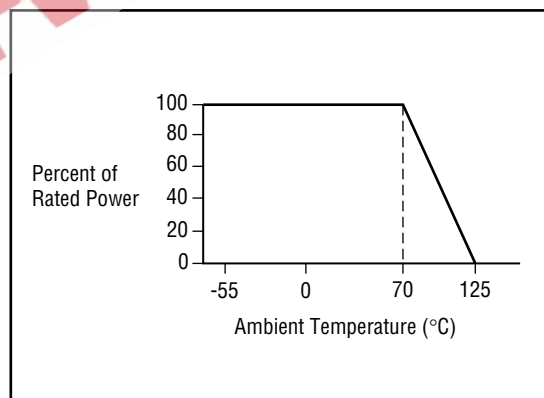

PACKAGING

Standard:	Plastic Bags
	Capacity = 200 Units

OUTLINE DIMENSIONS (Inch/mm)

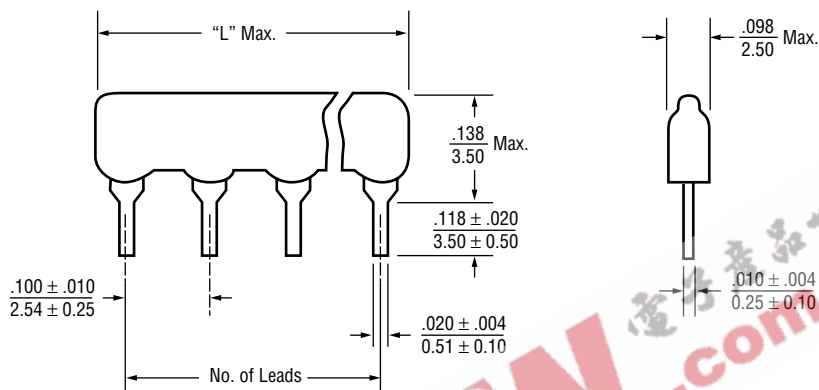

# of Leads	4	5	6	7	8	9	10	11	12	13	14
Dim. "L" Max.	.40 10.16	.50 12.70	.60 15.24	.70 17.78	.80 20.32	.90 22.86	1.00 25.40	1.10 27.94	1.20 30.48	1.30 33.02	1.40 35.56

4

SCHEMATICS

**-3 Circuit
Isolated Resistors**

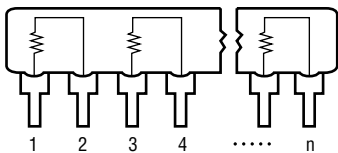

**-1 Circuit
Bussed Resistors**

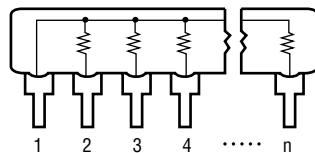

**-5 Circuit
Dual Terminator**

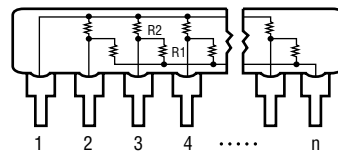

TYPICAL PART MARKING

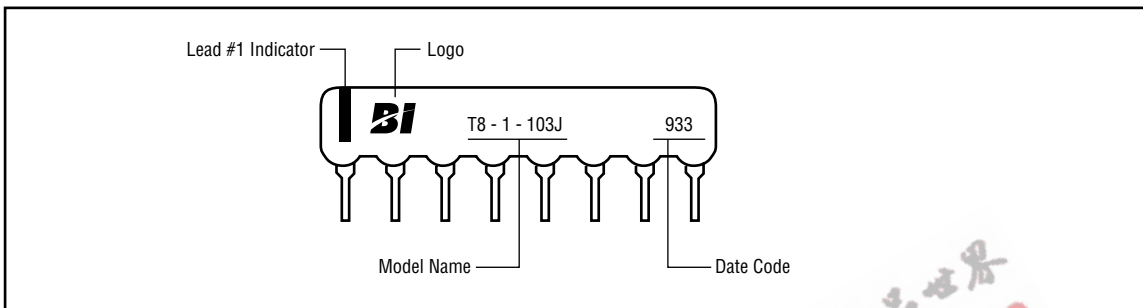

ORDERING INFORMATION

