

Temperature Compensated Crystal Oscillators (TCXO's)

TC-400 (14/4 Single DIP Series)

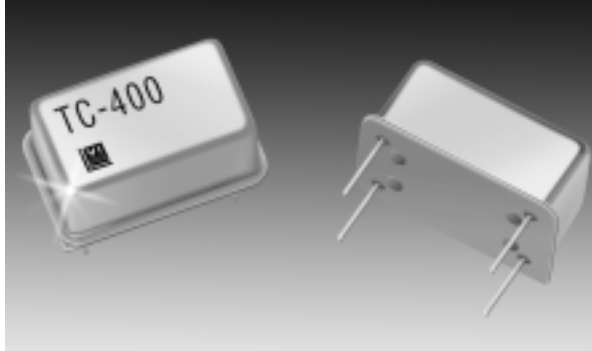

Description:

Vectron International has introduced a series of Temperature Compensated Crystal Oscillators (TCXO's) available in frequencies from 2 to 160 MHz.

Features:

- Industry Standard 14/4 Single DIP package
- Frequency from 2 to 160 MHz
- 3.3 Vdc or 5 Vdc operation
- All outputs Available (TTL, HCMOS, PECL, Sine)

Performance Characteristics

Parameter	Characteristic																								
Frequency:	Available from 2.0 MHz to 160 MHz																								
Supply Voltage (Vdd): (other options are available upon request)	5.0 Vdc $\pm 5\%$ 3.3 Vdc $\pm 5\%$																								
Current:	Current draw will vary greatly depending on frequency and output type. For this series TCXO typical current draw will be about 15 mA. Please consult the factory about your exact current requirements.																								
Output Type:	<table border="0"> <tr> <td>HCMOS/ACMOS</td> <td>2.0 to 160 MHz</td> </tr> <tr> <td>10 TTL</td> <td>2.0 to 160 MHz</td> </tr> <tr> <td>PECL</td> <td>10.0 to 160 MHz</td> </tr> <tr> <td>0 dBm/50 ohm</td> <td>16.384 to 77.76 MHz</td> </tr> </table>	HCMOS/ACMOS	2.0 to 160 MHz	10 TTL	2.0 to 160 MHz	PECL	10.0 to 160 MHz	0 dBm/50 ohm	16.384 to 77.76 MHz																
HCMOS/ACMOS	2.0 to 160 MHz																								
10 TTL	2.0 to 160 MHz																								
PECL	10.0 to 160 MHz																								
0 dBm/50 ohm	16.384 to 77.76 MHz																								
Temperature Stability: Note: Not all stabilities are available with all frequency/output combinations. Please consult the factory.	<table border="0"> <tr> <td>B-106</td> <td>- $\pm 1.0 \times 10^{-6}$ over</td> <td>0°C to +50°C</td> </tr> <tr> <td>B-156</td> <td>- $\pm 1.5 \times 10^{-6}$ over</td> <td>0°C to +50°C</td> </tr> <tr> <td>C-106</td> <td>- $\pm 1.0 \times 10^{-6}$ over</td> <td>0°C to +70°C</td> </tr> <tr> <td>C-156</td> <td>- $\pm 1.5 \times 10^{-6}$ over</td> <td>0°C to +70°C</td> </tr> <tr> <td>D-156</td> <td>- $\pm 1.5 \times 10^{-6}$ over</td> <td>-20°C to +70°C</td> </tr> <tr> <td>D-206</td> <td>- $\pm 2.0 \times 10^{-6}$ over</td> <td>-20°C to +70°C</td> </tr> <tr> <td>F-156</td> <td>- $\pm 1.5 \times 10^{-6}$ over</td> <td>-40°C to +85°C</td> </tr> <tr> <td>F-256</td> <td>- $\pm 2.5 \times 10^{-6}$ over</td> <td>-40°C to +85°C</td> </tr> </table> <p>NOTE: Tighter stabilities and wider temperature ranges are available, please consult the factory.</p>	B-106	- $\pm 1.0 \times 10^{-6}$ over	0°C to +50°C	B-156	- $\pm 1.5 \times 10^{-6}$ over	0°C to +50°C	C-106	- $\pm 1.0 \times 10^{-6}$ over	0°C to +70°C	C-156	- $\pm 1.5 \times 10^{-6}$ over	0°C to +70°C	D-156	- $\pm 1.5 \times 10^{-6}$ over	-20°C to +70°C	D-206	- $\pm 2.0 \times 10^{-6}$ over	-20°C to +70°C	F-156	- $\pm 1.5 \times 10^{-6}$ over	-40°C to +85°C	F-256	- $\pm 2.5 \times 10^{-6}$ over	-40°C to +85°C
B-106	- $\pm 1.0 \times 10^{-6}$ over	0°C to +50°C																							
B-156	- $\pm 1.5 \times 10^{-6}$ over	0°C to +50°C																							
C-106	- $\pm 1.0 \times 10^{-6}$ over	0°C to +70°C																							
C-156	- $\pm 1.5 \times 10^{-6}$ over	0°C to +70°C																							
D-156	- $\pm 1.5 \times 10^{-6}$ over	-20°C to +70°C																							
D-206	- $\pm 2.0 \times 10^{-6}$ over	-20°C to +70°C																							
F-156	- $\pm 1.5 \times 10^{-6}$ over	-40°C to +85°C																							
F-256	- $\pm 2.5 \times 10^{-6}$ over	-40°C to +85°C																							
Aging (typical):	<10 ppm for ten years @ +70°C																								
Frequency vs. Supply:	< ± 0.2 ppm for a $\pm 5\%$ change in supply voltage																								
Pin 1 Options:	<p>A = Electrical Frequency Adjust -- ± 10 ppm minimum via external voltage, 0 to Vdd - positive slope</p> <p>B = Tri-state -- HCMOS/TTL</p> <p>Enable/Disable -- PECL</p> <p>C = No connect -- Initial Accuracy ± 2.5 ppm @ +25°C</p>																								
Package Size:	20.32 x 12.70 x 10.287 mm (0.80" x 0.50" x 0.405")																								

Temperature Compensated Crystal Oscillators (TCXO's)

TC-400 (14/4 Single DIP Series)

Outline Drawing

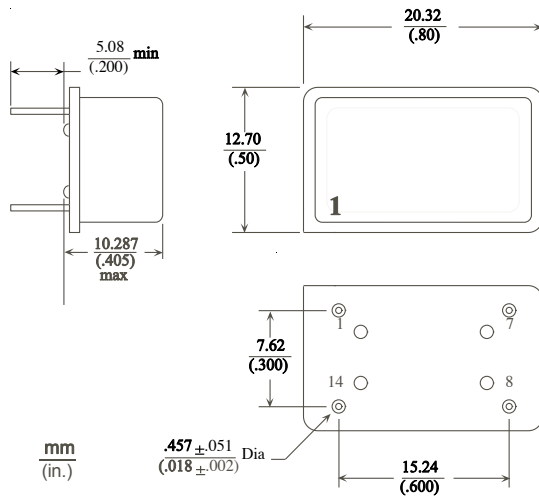

Standard Frequencies (MHz)

10.000	12.800	13.000
16.384	19.440	20.000
20.480	27.000	34.368
38.880	40.000	44.736
51.840	60.000	77.760
114.00	155.52	

Pin Out	
Pin	Function
1	See pin 1 options
7	Gnd
8	Output
14	Supply (Vdd)

Output Option	Logic			Sine	
	A	B	F	Output Option	G
Output	HCMOS/ACMOS	10 TTL	PECL	Output	Sinewave
Voh min..	0.8 (Vdd)	+2.4 Vdc	Vdd - 1.04 Vdc	Level	0 dBm to +6 dBm
Vol max.	+0.5 Vdc	+0.5 Vdc	Vcc - 1.60 Vdc	Load	50 ohm
Load (typical)	100 k ohm // 10 pF	10 TTL	50 ohms to Vcc -2V	Harmonics/subs	-20 dBc max.
Symmetry	50/50 ±10%	50/50 ±10%	50/50 ±10%	Other Spurious	-60 dBc max.
Rise/Fall Time	5 ns max.	10 ns max.	3 ns max.		

Ordering Information

