

C²MOS DIGITAL INTEGRATED CIRCUIT
SILICON MONOLITHIC

TC40H155P/F

TC40H155 DUAL 2-TO-4-LINE DECODER/DEMULTIPLEXER

The TC40H155 is a dual decoder/demultiplexer.

When STROBE="L", arbitrary one of four outputs can be selected by two common binary inputs A and B. The selected output goes to "L" level.

When the STROBE is set to "H" level, the output selection is inhibited, all the outputs go to "H" level regardless of other input signals.

Further, the TC40H155 can be used as 3-to-8-line decoder or 1-to-8-line demultiplexer by a combination of each input.

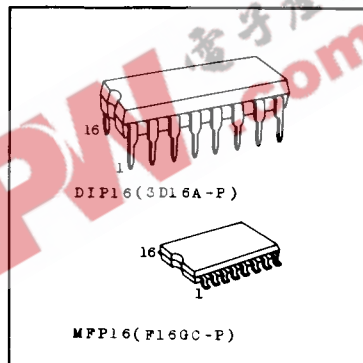

MAXIMUM RATING

CHARACTERISTIC	SYMBOL	RATING	UNIT
Supply Voltage	V _{DD}	V _{SS} -0.5 ~ V _{SS} +10	V
Input Voltage	V _{IN}	V _{SS} -0.5 ~ V _{DD} +0.5	V
Output Voltage	V _{OUT}	V _{SS} -0.5 ~ V _{DD} +0.5	V
Input Current	I _{IN}	±10	mA
Power Dissipation	P _D	300 (DIP)/180 (MFP)	mW
Storage Temperature	T _{stg}	-65 ~ 150	°C
Lead Temp./Time	T _{sol}	260°C • 10 sec	

PIN CONNECTION

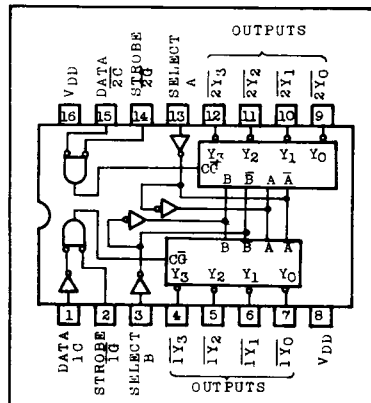

LOGIC DIAGRAM

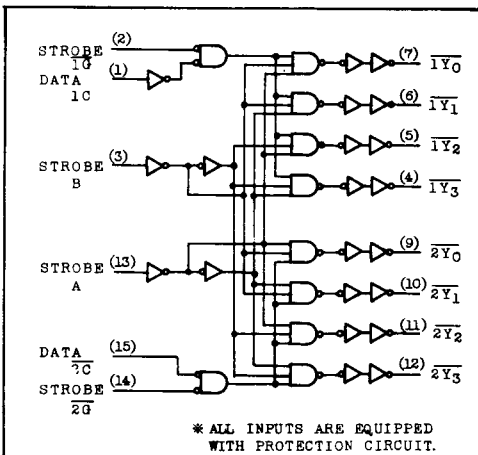

* ALL INPUTS ARE EQUIPPED WITH PROTECTION CIRCUIT.

RECOMMENDED OPERATING CONDITIONS (V_{SS}=0.0V)

CHARACTERISTIC	SYMBOL	MIN.	TYP.	MAX.	UNIT
Supply Voltage	V _{DD}	2.0	-	8.0	V
Input Voltage	V _{IN}	0	-	V _{DD}	V
Operating Temperature	T _{opr}	-40	-	85	°C

TC40H155P/F

TRUTH TABLE 1. 2-TO-4-LINE DECODER or 1-TO-4-LINE DEMULTIPLEXER

INPUTS				OUTPUTS			
SELECT	DATA	STROBE		1Y0	1Y1	1Y2	1Y3
A	B	1C	1G				
X	X	X	H	H	H	H	H
L	L	H	L	L	H	H	H
H	L	H	L	H	L	H	H
L	H	H	L	H	H	L	H
H	H	H	L	H	H	H	L
X	X	L	X	H	H	H	H

INPUTS				OUTPUTS			
SELECT	DATA	STROBE		2Y0	2Y1	2Y2	2Y3
A	B	2C	2G				
X	X	X	H	H	H	H	H
L	L	L	L	L	H	H	H
H	L	L	L	H	L	H	H
L	H	L	L	H	H	L	H
H	H	L	L	H	H	H	L
X	X	H	X	H	H	H	H

X=Don't care

TRUTH TABLE 2. 3-TO-8-LINE DECODER or 1-TO-8-LINE DEMULTIPLEXER

INPUTS				OUTPUTS							
SELECT		DATA	STROBE	(0)	(1)	(2)	(3)	(4)	(5)	(6)	(7)
A	B	* C	** G	2Y0	2Y1	2Y2	2Y3	1Y0	1Y1	1Y2	1Y3
X	X	X	H	H	H	H	H	H	H	H	H
L	L	L	L	L	H	H	H	H	H	H	H
H	L	L	L	H	L	H	H	H	H	H	H
L	H	L	L	H	H	L	H	H	H	H	H
H	H	L	L	H	H	H	L	H	H	H	H
L	L	H	L	H	H	H	H	L	H	H	H
H	L	H	L	H	H	H	H	H	L	H	H
L	H	H	L	H	H	H	H	H	H	L	H
H	H	H	L	H	H	H	H	H	H	H	L

* C=1C+2C ** G=1G+2G X=Don't Care

ELECTRICAL CHARACTERISTICS (V_{SS}=0.0V)

CHARACTERISTIC	SYMBOL	TEST CONDITION	V _{DD} (V)	-40°C		25°C			85°C		UNIT
				MIN.	MAX.	MIN.	TYP.	MAX.	MIN.	MAX.	
High Level Output Voltage	V _{OH}	I _{OUT} < 1μA V _{IN} =V _{SS} , V _{DD}	5	4.95	-	4.95	5.0	-	4.95	-	V
Low Level Output Voltage	V _{OL}	I _{OUT} < 1μA V _{IN} =V _{SS} , V _{DD}	5	-	0.05	-	0.0	0.05	-	0.05	V
High Level Output Current	I _{OH}	V _{OH} =4.6V V _{IN} =V _{SS} , V _{DD}	5	-0.52	-	-0.44	-	-	-0.36	-	mA
Low Level Output Current	I _{OL}	V _{OL} =0.4V V _{IN} =V _{SS} , V _{DD}	5	1.4	-	1.1	-	-	0.8	-	mA
Input Voltage	"H" Level	V _{IH}	5	4.0	-	4.0	-	-	4.0	-	V
	"L" Level	V _{IL}									
Input Current	"H" Level	I _{IH}	8	-	0.3	-	10 ⁻⁵	0.3	-	1.0	μA
	"L" Level	I _{IL}	8	-	-0.3	-	-10 ⁻⁵	-0.5	-	-1.0	μA
Quiescent Supply Current	I _{DD}	*V _{IN} =V _{SS} , V _{DD}	-	-	12.5	-	10 ⁻³	12.5	-	75	μA

* All valid input combinations.

TC40H155P/F

SWITCHING CHARACTERISTIC (Ta=25°C, VSS=0V, VDD=5V, CL=15pF)

CHARACTERISTIC	SYMBOL	TEST CONDITION	MIN.	TYP.	MAX.	UNIT
Output Rise Time	t _{or}		-	17	35	ns
Output Fall Time	t _{of}		-	14	30	ns
Propagation Delay Time	(Low-High)	t _{pLH}	SELECT A - \bar{Y}	32	48	ns
	(High-Low)	t _{pHL}	SELECT B - \bar{Y}	28	42	
Propagation Delay Time	(Low-High)	t _{pLH}	STROBE $\bar{1G}$ - \bar{Y}	30	46	ns
	(High-Low)	t _{pHL}	STROBE $\bar{2C}$ - \bar{Y}	26	42	
Propagation Delay Time	(Low-High)	t _{pLH}	DATA $1C$ - \bar{Y}	30	46	ns
	(High-Low)	t _{pHL}		26	42	
Propagation Delay Time	(Low-High)	t _{pLH}	DATA $\bar{2C}$ - \bar{Y}	30	46	ns
	(High-Low)	t _{pHL}		26	42	
Input Capacitance	C _{IN}		-	5	-	pF

SWITCHING TIME TEST CIRCUIT AND WAVEFORM

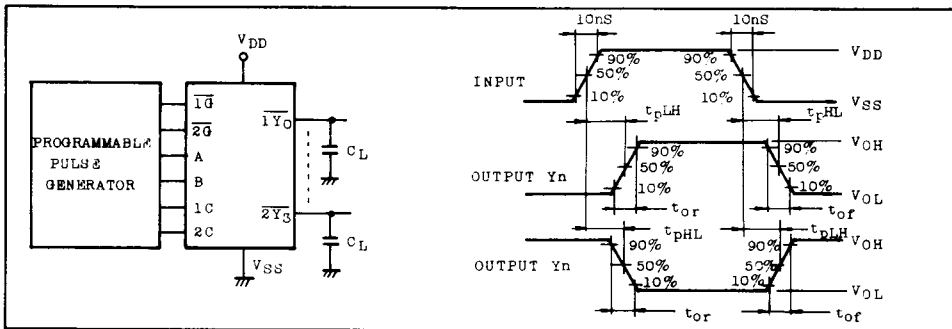

t_{pd} - VDD

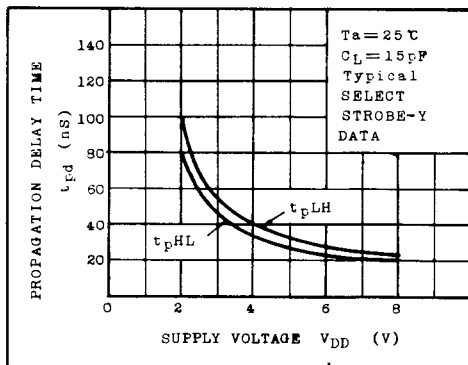

t_{pd} - CL

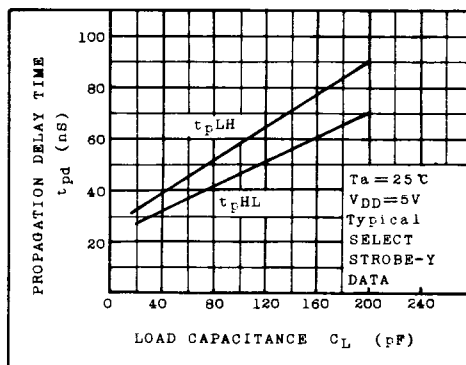

TC40H155P/F

