

## 9A HIGH-SPEED MOSFET DRIVERS

### FEATURES

- Tough CMOS™ Construction
- High Peak Output Current ..... 9A
- High Continuous Output Current ..... 2A Max
- Fast Rise and Fall Times:
  - 30 nsec with 4,700 pF Load
  - 180 nsec with 47,000 pF Load
- Short Internal Delays ..... 30nsec Typ
- Low Output Impedance ..... 1.4W Typ

### APPLICATIONS

- Line Drivers for Extra-Heavily-Loaded Lines
- Pulse Generators
- Driving the Largest MOSFETs and IGBTs
- Local Power ON/OFF Switch
- Motor and Solenoid Driver

### PIN CONFIGURATIONS

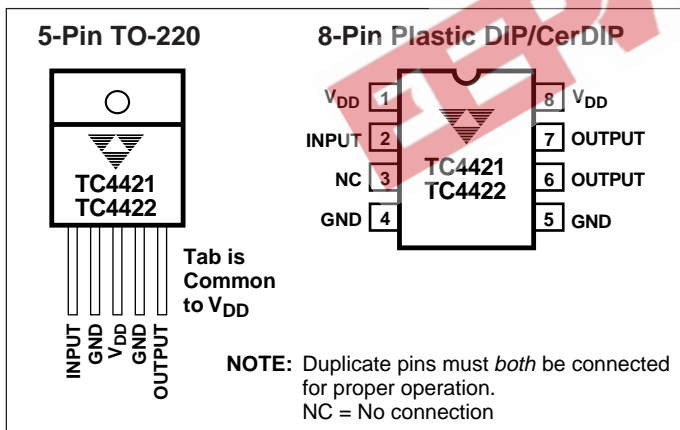

### GENERAL DESCRIPTION

The TC4421/4422 are high current buffer/drivers capable of driving large MOSFETs and IGBTs.

They are essentially immune to any form of upset except direct overvoltage or over-dissipation — they cannot be latched under any conditions within their power and voltage ratings; they are not subject to damage or improper operation when up to 5V of ground bounce is present on their ground terminals; they can accept, without either damage or logic upset, more than 1A inductive current of either polarity being forced back into their outputs. In addition, all terminals are fully protected against up to 4 kV of electrostatic discharge.

The TC4421/4422 inputs may be driven directly from either TTL or CMOS (3V to 18V). In addition, 300 mV of hysteresis is built into the input, providing noise immunity and allowing the device to be driven from slowly rising or falling waveforms.

### ORDERING INFORMATION

Part No.	Package	Temperature Range
TC4421CAT	5-Pin TO-220	0°C to +70°C
TC4421CPA	8-Pin PDIP	0°C to +70°C
TC4421EPA	8-Pin PDIP	-40°C to +85°C
TC4421MJA	8-Pin CerDIP	-55°C to +125°C
TC4422CAT	5-Pin TO-220	0°C to +70°C
TC4422CPA	8-Pin PDIP	0°C to +70°C
TC4422EPA	8-Pin PDIP	-40°C to +85°C
TC4422MJA	8-Pin CerDIP	-55°C to +125°C

### FUNCTIONAL BLOCK DIAGRAM

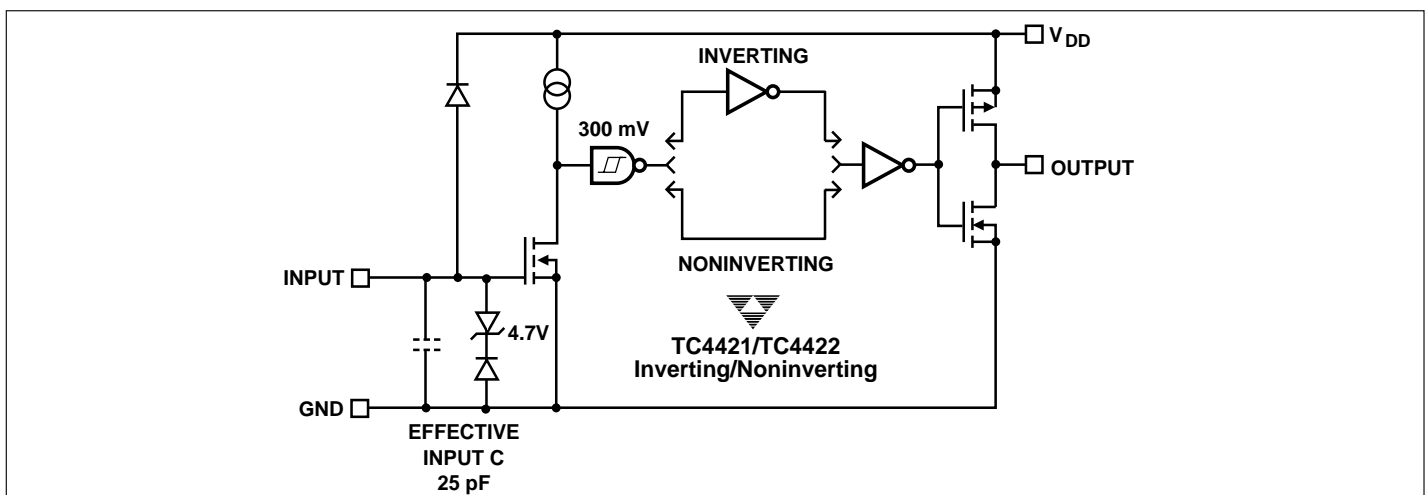

## 9A HIGH-SPEED MOSFET DRIVERS

### TC4421 TC4422

#### ABSOLUTE MAXIMUM RATINGS\*

Power Dissipation, $T_A \leq 70^\circ\text{C}$	
PDIP .....	730W
CerDIP .....	800mW
5-Pin TO-220 .....	1.6W
Power Dissipation, $T_A \leq 70^\circ\text{C}$	
5-Pin TO-220 (With Heat Sink) .....	1.60W
Derating Factors (To Ambient)	
PDIP .....	8mW/ $^\circ\text{C}$
CerDIP .....	6.4mW/ $^\circ\text{C}$
5-Pin TO-220 .....	12mW/ $^\circ\text{C}$
Thermal Impedance (To Case)	
5-Pin TO-220 $R_{\text{QJ-C}}$ .....	10 $^\circ\text{C/W}$
Storage Temperature .....	- 65 $^\circ\text{C}$ to +150 $^\circ\text{C}$
Operating Temperature (Chip) .....	150 $^\circ\text{C}$

#### Operating Temperature (Ambient)

C Version .....	0 $^\circ\text{C}$ to +70 $^\circ\text{C}$
E Version .....	- 40 $^\circ\text{C}$ to +85 $^\circ\text{C}$
M Version .....	- 55 $^\circ\text{C}$ to +125 $^\circ\text{C}$
Lead Temperature (10 sec) .....	300 $^\circ\text{C}$
Supply Voltage .....	20V
Input Voltage .....	( $V_{\text{DD}} + 0.3\text{V}$ ) to (GND - 5V)
Input Current ( $V_{\text{IN}} > V_{\text{DD}}$ ) .....	50 mA

\*Static-sensitive device. Unused devices must be stored in conductive material. Protect devices from static discharge and static fields. Stresses above those listed under "Absolute Maximum Ratings" may cause permanent damage to the device. These are stress ratings only and functional operation of the device at these or any other conditions above those indicated in the operation sections of the specifications is not implied. Exposure to absolute maximum rating conditions for extended periods may affect device reliability.

#### ELECTRICAL CHARACTERISTICS: $T_A = 25^\circ\text{C}$ with $4.5\text{V} \leq V_{\text{DD}} \leq 18\text{V}$ unless otherwise specified.

Symbol	Parameter	Test Conditions	Min	Typ	Max	Unit
<b>Input</b>						
$V_{\text{IH}}$	Logic 1 Input Voltage		2.4	1.8	—	V
$V_{\text{IL}}$	Logic 0 Input Voltage		—	1.3	0.8	V
$I_{\text{IN}}$	Input Current	$0\text{V} \leq V_{\text{IN}} \leq V_{\text{DD}}$	- 10	—	10	$\mu\text{A}$
<b>Output</b>						
$V_{\text{OH}}$	High Output Voltage	See Figure 1	$V_{\text{DD}} - 0.025$	—	—	V
$V_{\text{OL}}$	Low Output Voltage	See Figure 1	—	—	0.025	V
$R_{\text{O}}$	Output Resistance, High	$V_{\text{DD}} = 18\text{V}$ , $I_{\text{O}} = 10\text{ mA}$	—	1.4	—	$\Omega$
$R_{\text{O}}$	Output Resistance, Low	$V_{\text{DD}} = 18\text{V}$ , $I_{\text{O}} = 10\text{ mA}$	—	0.9	1.7	$\Omega$
$I_{\text{PK}}$	Peak Output Current	$V_{\text{DD}} = 18\text{V}$	—	9	—	A
$I_{\text{DC}}$	Continuous Output Current	$10\text{V} \leq V_{\text{DD}} \leq 18\text{V}$ , $T_{\text{C}} = 25^\circ$ (TC4421/22 CAT only)	2	—	—	A
$I_{\text{REV}}$	Latch-Up Protection	Duty Cycle $\leq 2\%$ Withstand Reverse Current	>1500 $t \leq 300\ \mu\text{sec}$	—	—	mA

#### Switching Time (Note 1)

$t_{\text{R}}$	Rise Time	Figure 1, $C_{\text{L}} = 10,000\text{ pF}$	—	60	75	nsec
$t_{\text{F}}$	Fall Time	Figure 1, $C_{\text{L}} = 10,000\text{ pF}$	—	60	75	nsec
$t_{\text{D1}}$	Delay Time	Figure 1	—	30	60	nsec
$t_{\text{D2}}$	Delay Time	Figure 1	—	33	60	nsec

#### Power Supply

$I_{\text{S}}$	Power Supply Current	$V_{\text{IN}} = 3\text{V}$ $V_{\text{IN}} = 0\text{V}$	— —	0.2 55	1.5 150	mA $\mu\text{A}$
$V_{\text{DD}}$	Operating Input Voltage		4.5	—	18	V

#### Input

$V_{\text{IH}}$	Logic 1 Input Voltage		2.4	—	—	V
$V_{\text{IL}}$	Logic 0 Input Voltage		—	—	0.8	V
$I_{\text{IN}}$	Input Current	$0\text{V} \leq V_{\text{IN}} \leq V_{\text{DD}}$	- 10	—	10	$\mu\text{A}$

# 9A HIGH-SPEED MOSFET DRIVERS

TC4421  
TC4422

## ELECTRICAL CHARACTERISTICS (cont.):

Measured over operating temperature range with  $4.5V \leq V_s \leq 18V$  unless otherwise specified.

Symbol	Parameter	Test Conditions	Min	Typ	Max	Unit
<b>Input</b>						
$V_{IH}$	Logic 1 Input Voltage		2.4	—	—	V
$V_{IL}$	Logic 0 Input Voltage		—	—	0.8	V
$I_{IN}$	Input Current	$0V \leq V_{IN} \leq V_{DD}$	-10	—	10	$\mu A$
<b>Output</b>						
$V_{OH}$	High Output Voltage	See Figure 1	$V_{DD} - 0.025$	—	—	V
$V_{OL}$	Low Output Voltage	See Figure 1	—	—	0.025	V
$R_O$	Output Resistance, High	$V_{DD} = 18V, I_O = 10\text{ mA}$	—	2.4	3.6	$\Omega$
$R_O$	Output Resistance, Low	$V_{DD} = 18V, I_O = 10\text{ mA}$	—	1.8	2.7	$\Omega$
<b>Switching Time (Note 1)</b>						
$t_R$	Rise Time	Figure 1, $C_L = 10,000\text{ pF}$	—	60	120	nsec
$t_F$	Fall Time	Figure 1, $C_L = 10,000\text{ pF}$	—	60	120	nsec
$t_{D1}$	Delay Time	Figure 1	—	50	80	nsec
$t_{D2}$	Delay Time	Figure 1	—	65	80	nsec
<b>Power Supply</b>						
$I_S$	Power Supply Current	$V_{IN} = 3V$ $V_{IN} = 0V$	—	0.45 0.06	3 0.2	mA
$V_{DD}$	Operating Input Voltage		4.5	—	18	V

**NOTE:** 1. Switching times guaranteed by design.

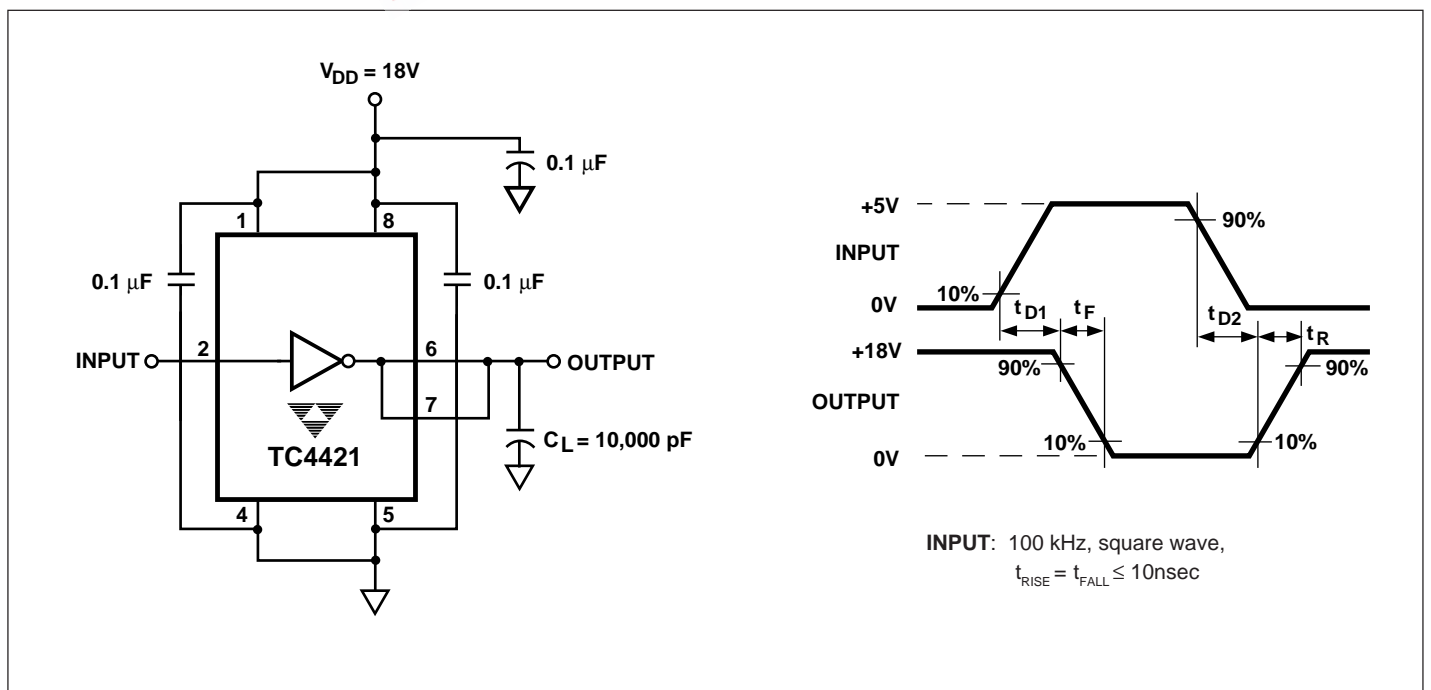
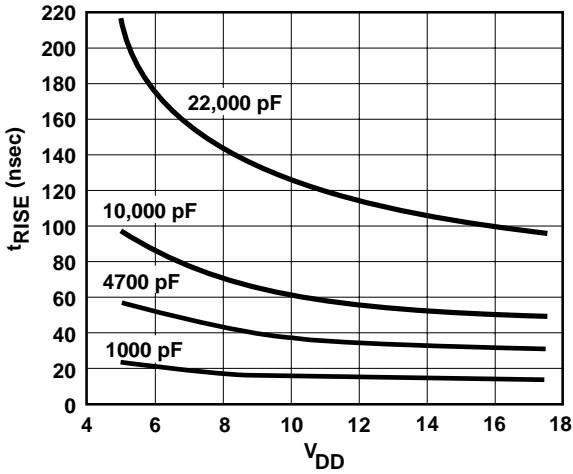

Figure 1. Switching Time Test Circuit

TC4421  
TC4422

TYPICAL CHARACTERISTICS

Rise Time vs. Supply Voltage



Fall Time vs. Supply Voltage

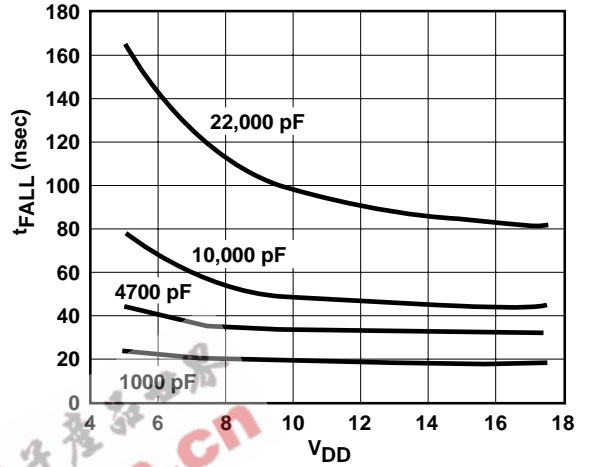

Rise Time vs. Capacitive Load

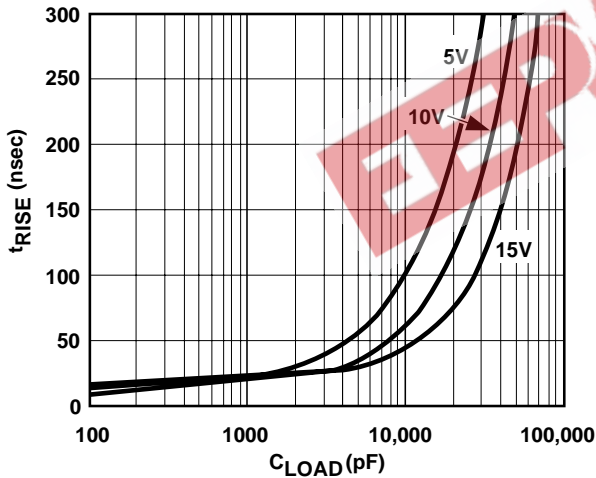

Fall Time vs. Capacitive Load

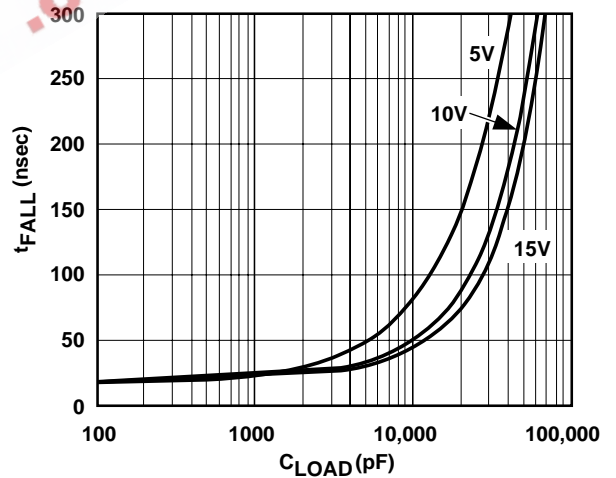

Rise and Fall Times vs. Temperature

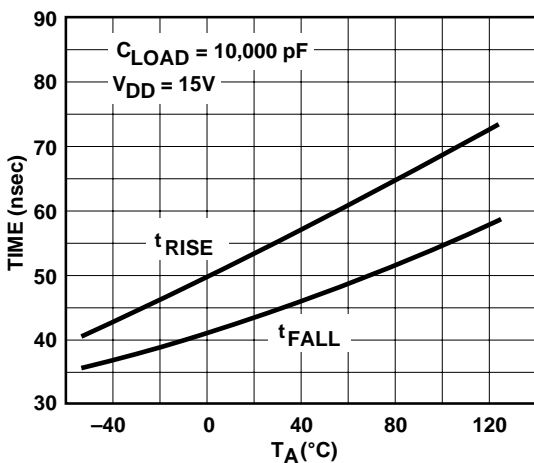

Propagation Delay vs. Supply Voltage

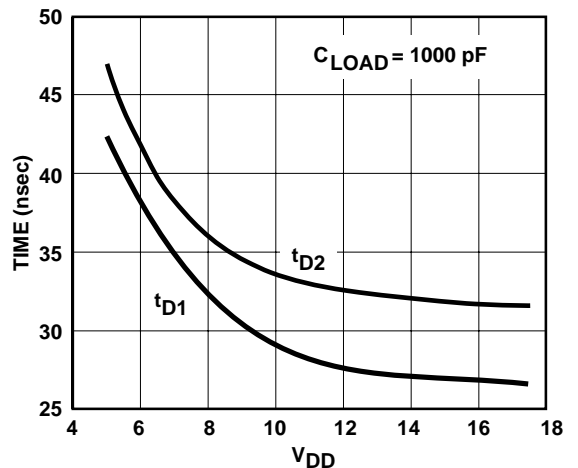

TYPICAL CHARACTERISTICS (Cont.)

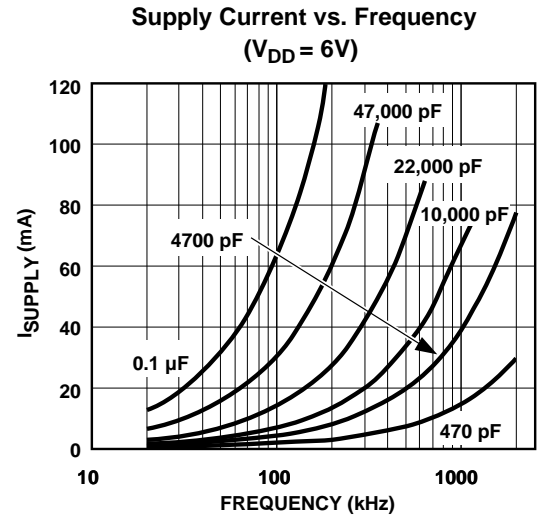
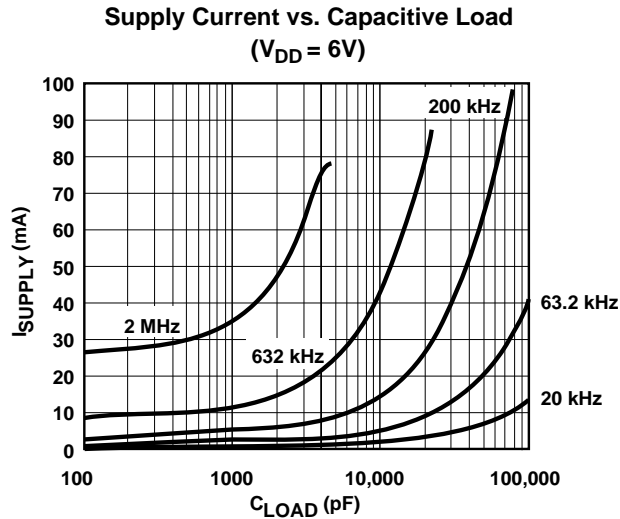
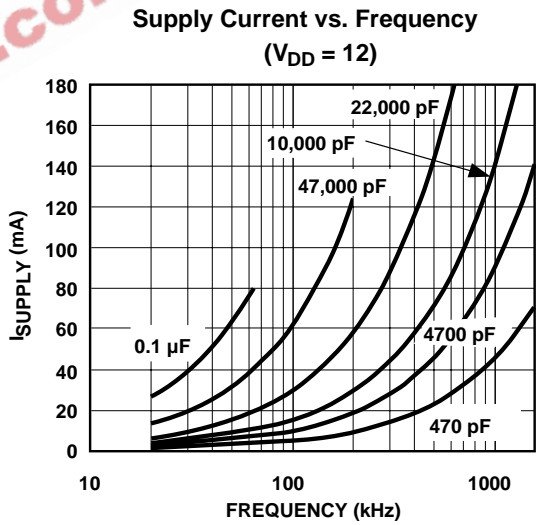
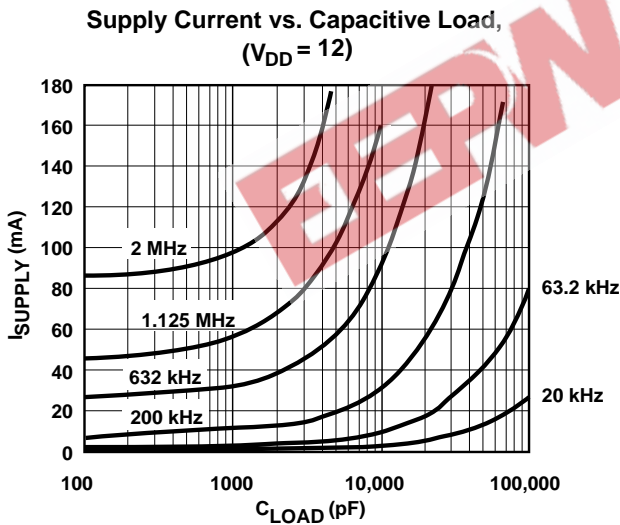
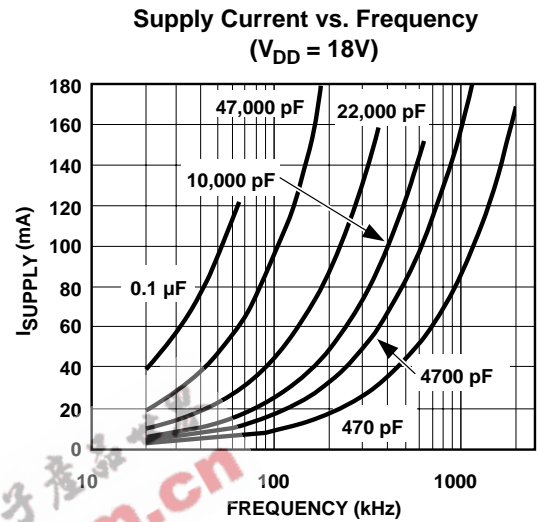
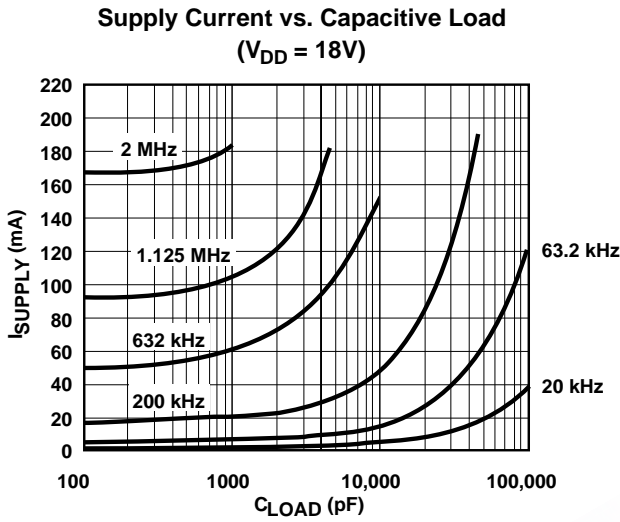

# 9A HIGH SPEED MOSFET DRIVERS

TC4421  
TC4422

## TYPICAL CHARACTERISTICS (Cont.)

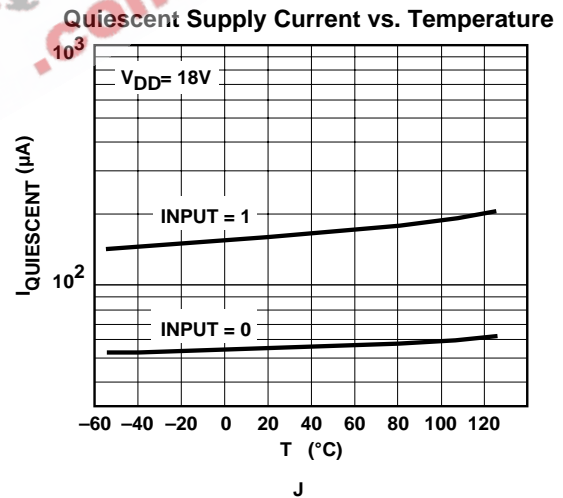
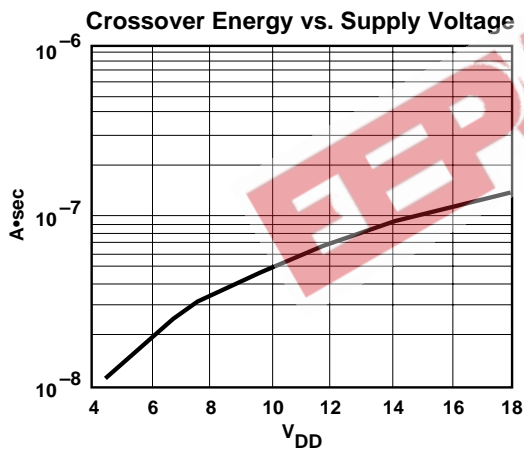
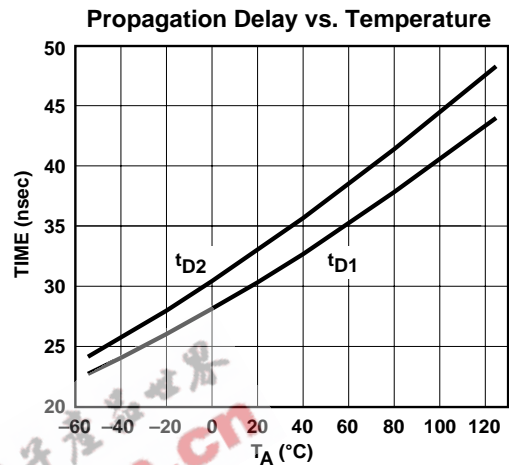
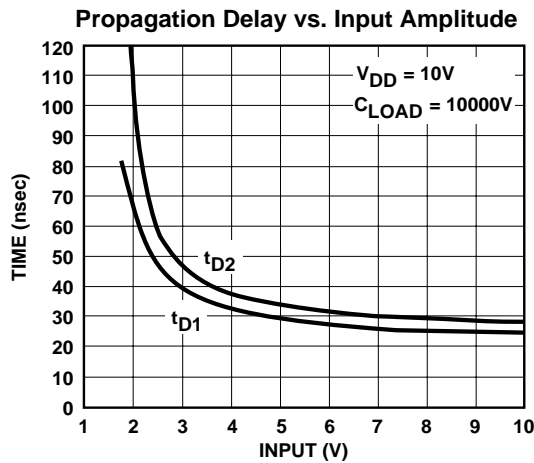

**NOTE:** The values on this graph represent the loss seen by the driver during a complete cycle. For the loss in a single transition, divide the stated value by 2.

