

INTERFACE CIRCUIT (RELAY AND LAMP-DRIVER)

- OPEN GROUND PROTECTION
- HIGH OUTPUT CURRENT
- ADJUSTABLE SHORT-CIRCUIT PROTECTION
- INTERNAL THERMAL PROTECTION WITH EXTERNAL RESET
- LARGE SUPPLY VOLTAGE RANGE
- ALARM OUTPUT
- INPUT VOLTAGE CAN BE HIGHER THAN V_{CC}
- OUTPUT VOLTAGE CAN BE LOWER THAN GROUND ($V_{CC} - V_O \leq V_{CC}[\max]$)

DESCRIPTION

The TDE1767, A/TDE1787, A are a monolithic amplifiers designed for high current and high voltage applications, specifically to drive lamps, relays, stepping motors.

The devices are essentially blow-out proof. The output is protected from short-circuits with the positive supply or drive. In addition thermal shut down is provided to keep the IC from overheating. If internal dissipation becomes too high, the driver will shut down to prevent excessive heating. The output stays null after the overheating is off, if the reset input is low. If high the output will alternatively switch-on and off until the overload is removed.

The devices operates over a wide range voltages from standard 15 V operational amplifier supplies to the single +6V or +48V used for industrial electric systems. Input voltages can be higher than in the V_{CC} .

An alarm output suitable for driving a LED is provided. This LED, normally on (if referred to ground), will die out or flash during an overload depending on the state of the reset input.

The output is low in open ground conditions.

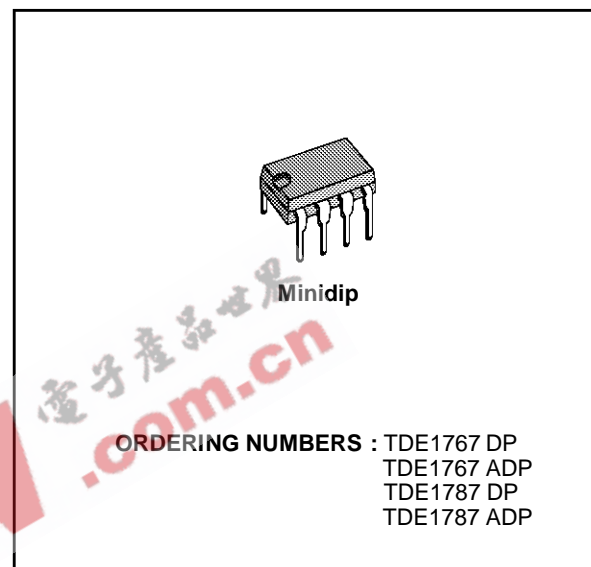

PIN CONNECTION (top view)

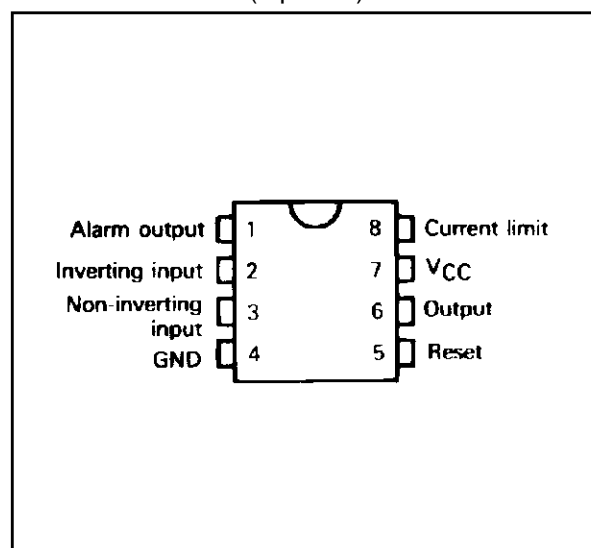

THERMAL DATA

Symbol	Parameter	Value	Unit
$R_{th(j-c)}$	Maximum Junction-case Thermal Resistance	30	$^{\circ}C/W$
$R_{th(j-a)}$	Maximum Junction-ambient Thermal Resistance	80	$^{\circ}C/W$

* Devices bonded on a 40 cm² glass-epoxy printed circuit 0.15 cm thick with 4 cm² of copper.

TDE1767,A-TDE1787,A

ABSOLUTE MAXIMUM RATINGS

Symbol	Parameter	TDE1767A/TDE1787A	TDE1767/TDE1787	Unit
V_{CC}	Supply Voltage	60	50	V
V_{ID}	Input Differential Voltage	60	50	V
V_I	Input Voltage	- 10 to + 60	- 10 to + 50	V
I_o	Output Current	1.3	1.2	A
$V_{I(reset)}$	Reset Input Voltage	- 0.5 to + 60	- 0.5 to + 50	V
I_{OA}	Alarm Output Current	- 10 to + 20	- 10 to + 20	mA
P_{tot}	Power Dissipation	Internally Limited		mW
T_{oper}	Operating Ambient Temperature Range	- 25 to + 85	- 25 to + 85	°C
T_{stg}	Storage Temperature Range	- 65 to + 150	- 65 to + 150	°C

SCHEMATIC DIAGRAM

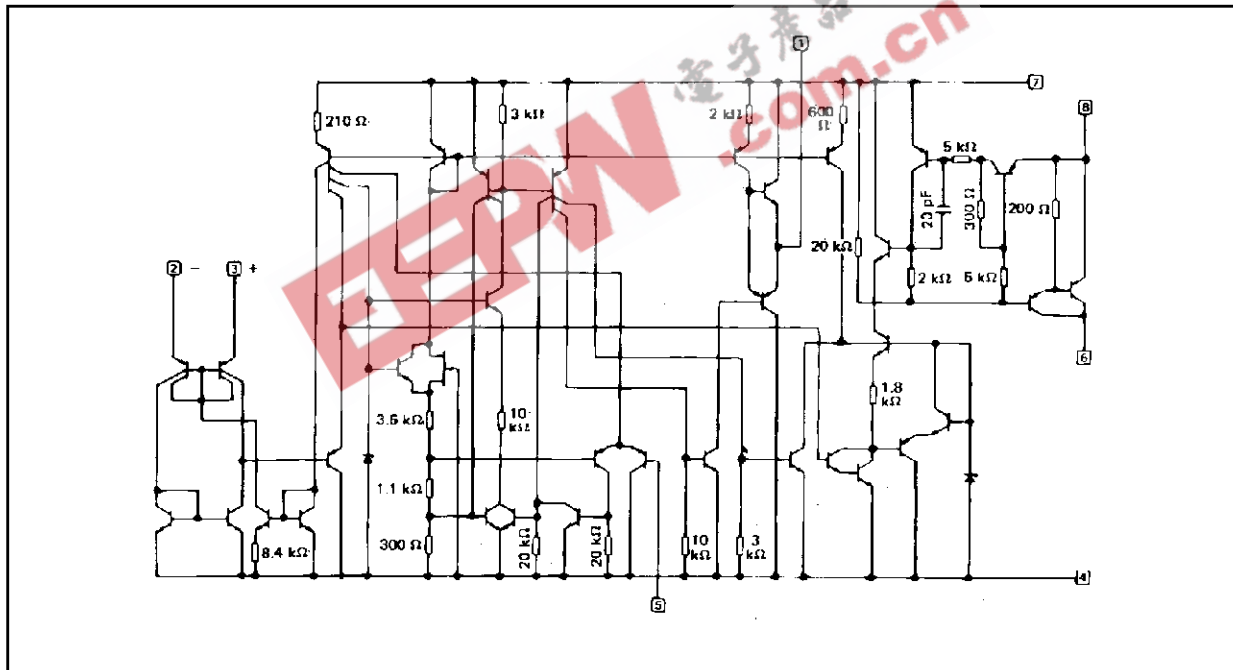

EQUIVALENT SCHEMATIC

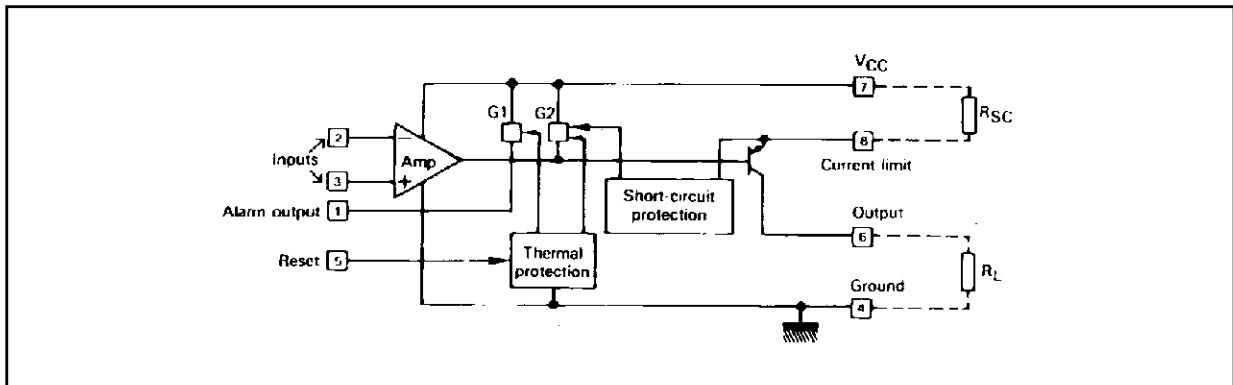
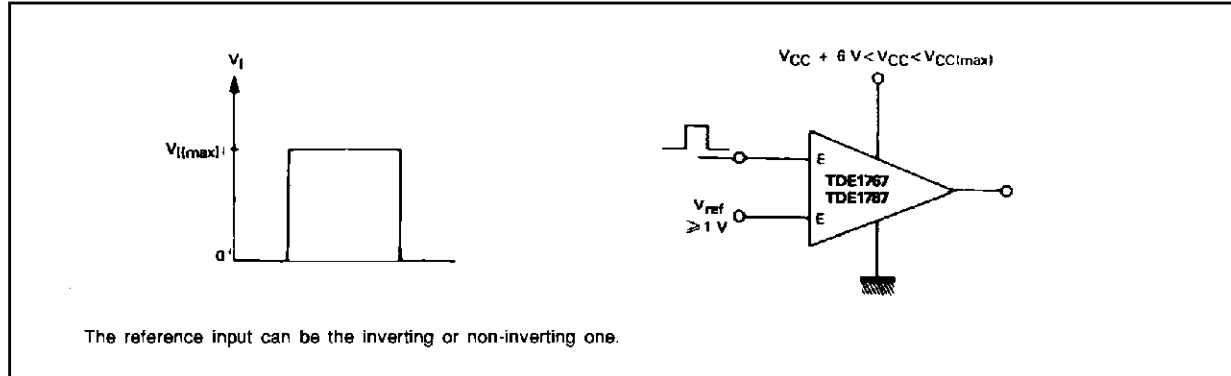

Figure 1.

**ELECTRICAL CHARACTERISTICS** (Unless otherwise specified)

TDE1767A: $-25\text{ }^{\circ}\text{C} \leq T_{\text{amb}} \leq +85\text{ }^{\circ}\text{C}$, $+6\text{ V} \leq V_{\text{CC}} \leq +55\text{ V}$, $I_{\text{o}} \leq 500\text{ mA}$, $T_{\text{j}} \leq +150\text{ }^{\circ}\text{C}$

TDE1767: $-25\text{ }^{\circ}\text{C} \leq T_{\text{amb}} \leq +85\text{ }^{\circ}\text{C}$, $+6\text{ V} \leq V_{\text{CC}} \leq +45\text{ V}$, $I_{\text{o}} \leq 500\text{ mA}$, $T_{\text{j}} \leq +150\text{ }^{\circ}\text{C}$

TDE1787A: $-25\text{ }^{\circ}\text{C} \leq T_{\text{amb}} \leq +85\text{ }^{\circ}\text{C}$, $+6\text{ V} \leq V_{\text{CC}} \leq +55\text{ V}$, $I_{\text{o}} \leq 300\text{ mA}$, $T_{\text{j}} \leq +150\text{ }^{\circ}\text{C}$

TDE1767A: $-25\text{ }^{\circ}\text{C} \leq T_{\text{amb}} \leq +85\text{ }^{\circ}\text{C}$, $+6\text{ V} \leq V_{\text{CC}} \leq +45\text{ V}$, $I_{\text{o}} \leq 300\text{ mA}$, $T_{\text{j}} \leq +150\text{ }^{\circ}\text{C}$

Symbol	Parameter	Min.	Typ.	Max.	Unit	
V_{IO}	Input Offset Voltage - (note 1)		2	50	mV	
I_{CC}	Power Supply Current (measured on pin 4)				mA	
	Output High ($T_{\text{amb}} = +25\text{ }^{\circ}\text{C}$)	-	5.8	8		
	Output High ($V_{\text{CC}} = V_{\text{CC(max)}}$, $T_{\text{j}} = +150\text{ }^{\circ}\text{C}$)	-	5	7		
	Output Low ($V_{\text{CC}} = V_{\text{CC(max)}}$, $T_{\text{amb}} = +25\text{ }^{\circ}\text{C}$)	-	1.5	4		
I_{IB}	Input Bias Current	-	15	100	μA	
V_{CM}	Common-mode Input Voltage Range	TDE1787A, TDE1767A TDE1787, TDE1767	1 1	- -	60 45	V
V_{I}	Input Voltage Range ($V_{\text{ref}} \geq +1\text{ V}$) (figure 1, note 2)	TDE1787A, TDE1767A TDE1787, TDE1767	0 0	- -	60 45	V
I_{SC}	Short-circuit Output Current ($V_{\text{CC}} = +35\text{ V}$, $t = 10\text{ ms}$)				mA	
	$R_{\text{SC}} = 0.22\ \Omega$	TDE1767A	-	700	-	
	$R_{\text{SC}} = 0.33\ \Omega$	TDE1787A	-	380	-	
V_{sense}	Output Limit Sense Voltage: $V_{\text{O}} = V_{\text{CC}} - 2\text{ V}$, $t = 10\text{ ms}$ ($V_{\text{O}} = V_{\text{CC}} - 2\text{ V}$) : $V_{\text{O}} = 0\text{ V}$, $t = 10\text{ ms}$		130 120	150 140	170 165	mV
$V_{\text{O(sat)}}$	Output Saturation Voltage (output high $V_{\text{I}}^{+} - V_{\text{I}}^{-} \geq 50\text{ mV}$, $R_{\text{SC}} = 0$, $V_{\text{CC}} = +30\text{ V}$)				V	
	$T_{\text{j}} = +25\text{ }^{\circ}\text{C}$	TDE1787A, TDE1767A TDE1787, TDE1767	- -	1 1	1.1 1.2	
	$T_{\text{j}} = +150\text{ }^{\circ}\text{C}$	TDE1787A, TDE1767A TDE1787, TDE1767	- -	1.1 1.1	1.2 1.3	
I_{OL}	Output Leakage Current (output low)		-	-	100	μA
I_{A}	Available Alarm Output Current Output Source Current ($V_{\text{AH}} = V_{\text{CC}} - 2.5\text{ V}$) Output Slnk Current (in thermal shut-down) $V_{\text{A}} = 1.4\text{ V}$		-4 5	-5 10	- -	mA
I_{reset}	Reset Input Current		-	2	40	μA
$V_{\text{th (reset)}}$	Reset Threshold		-	1.4	-	V
-	Output Leakage Current (open ground)		-	10	-	μA

Notes: 1. The offset voltage given is the maximum value of different input voltage required to drive the output voltage within 2 V of the ground or the supply voltage.

2. Input voltage range is independent of the supply voltage.

Figure 2. PEAK SHORT-CIRCUIT vs LIMITING RESISTOR.

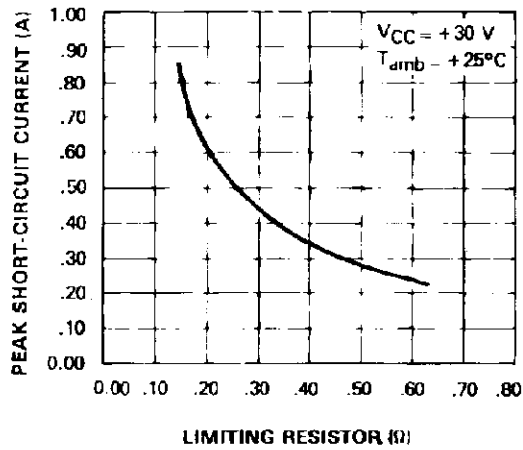

Figure 3. AVAILABLE OUTPUT CURRENT vs LIMITING RESISTOR.

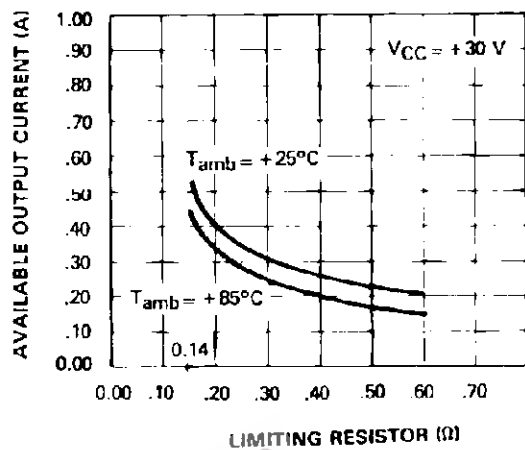

Figure 4. POWER SUPPLY CURRENT (pin 4).

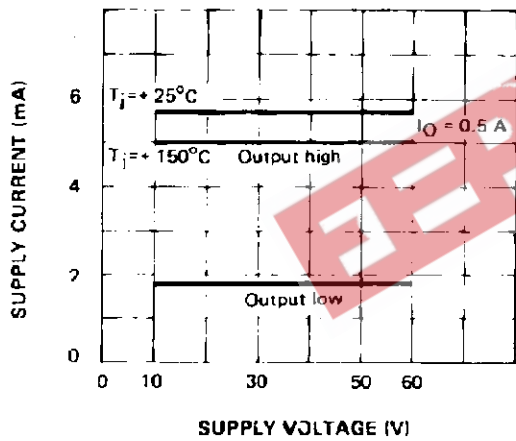

Figure 5. OUTPUT SATURATION VOLTAGE vs OUTPUT CURRENT.

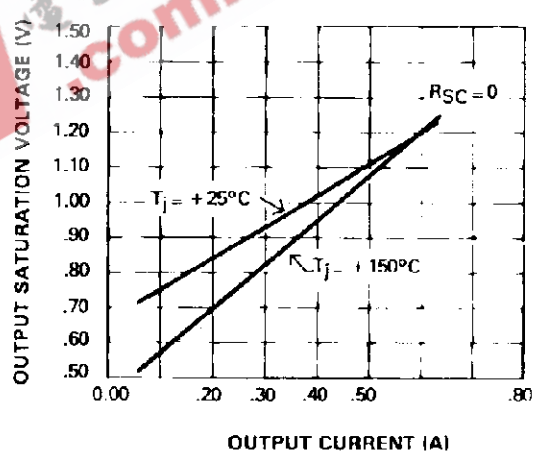

Figure 6. OUTPUT TRANSISTOR SAFE OPERATING AREA (pulsed)

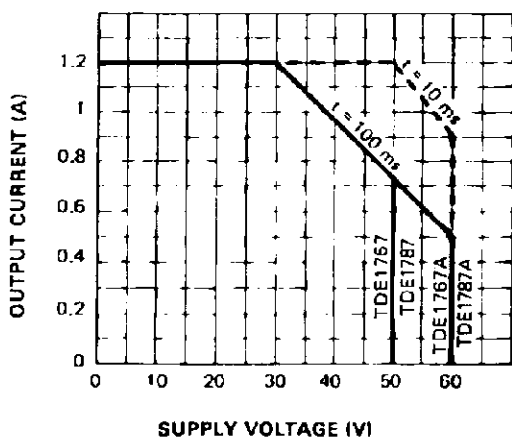
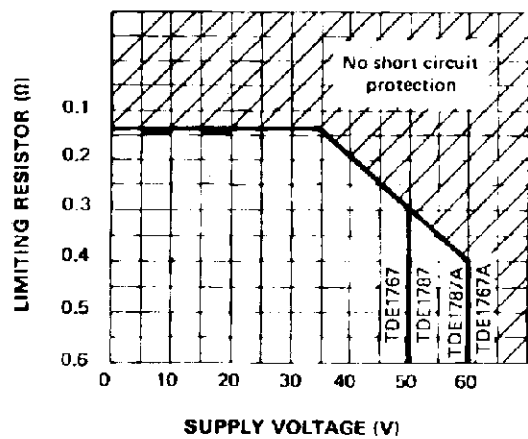

Figure 7. NORMAL OPERATING AREA (short circuit protected)



ALARM OUTPUT CAPABILITY CURRENT

Figure 8. CURRENT SINKING.

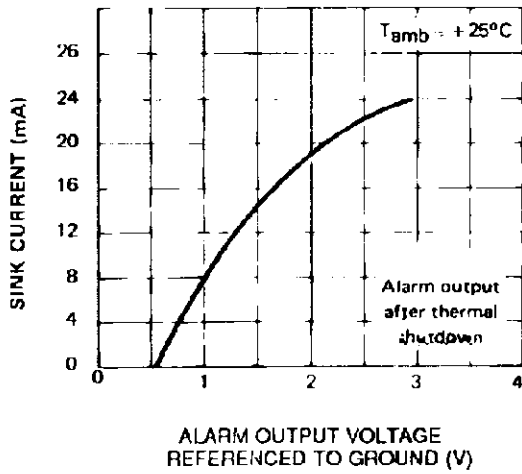

Figure 9. CURRENT SOURCING

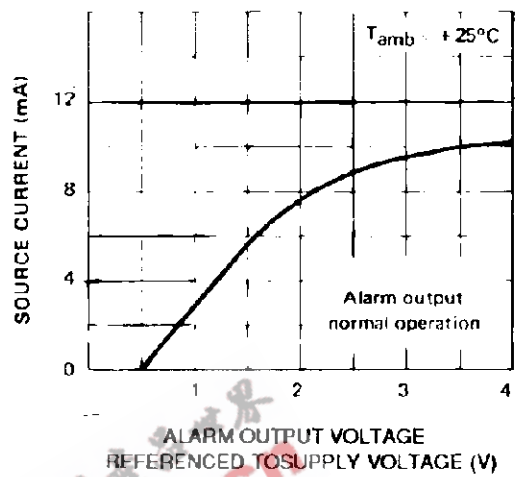

Figure 10. REPOSE TIME

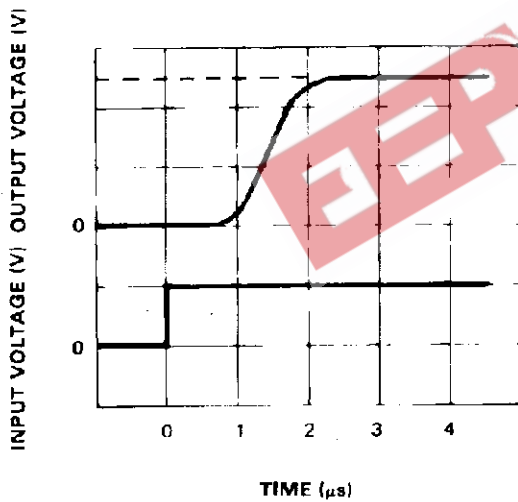

Figure 11. REPOSE TIME

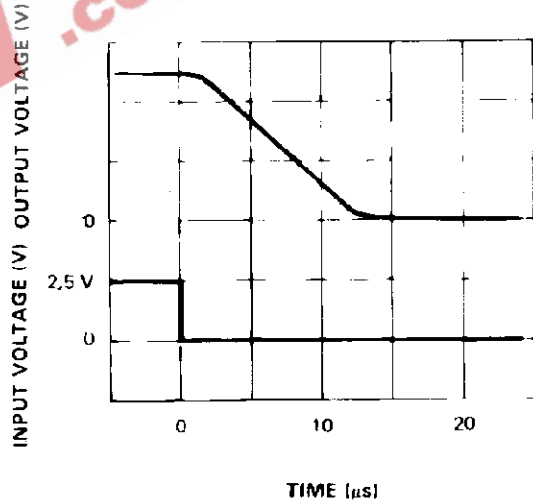
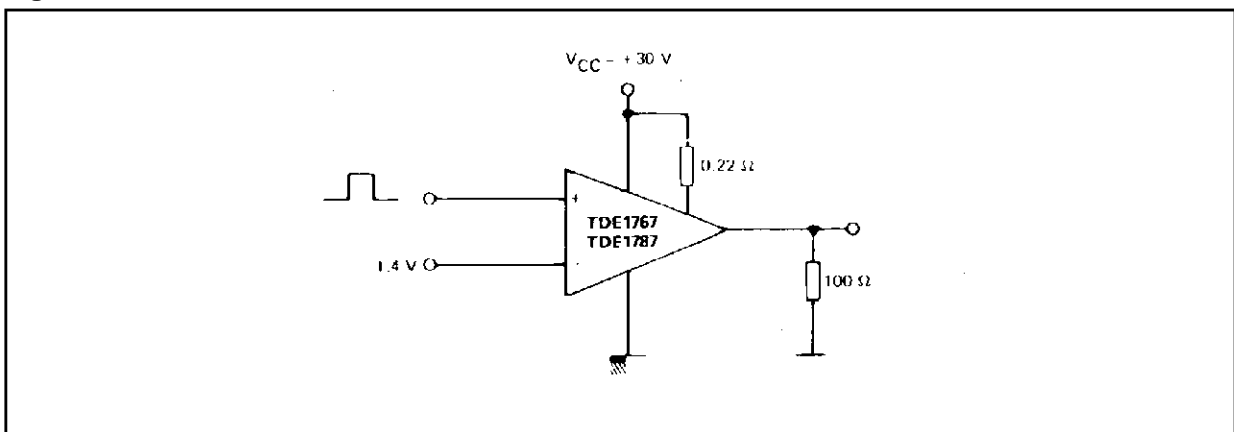

Figure 12 : Test Circuit.



TYPICAL APPLICATION

Figure 13. Open Load Detection.

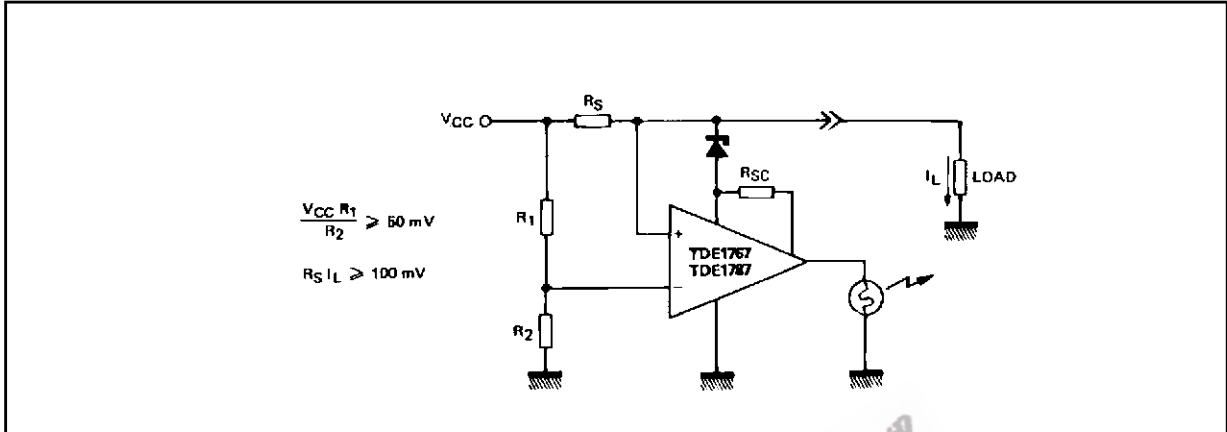

Figure 14. Driving Lamps, Relays, Etc...

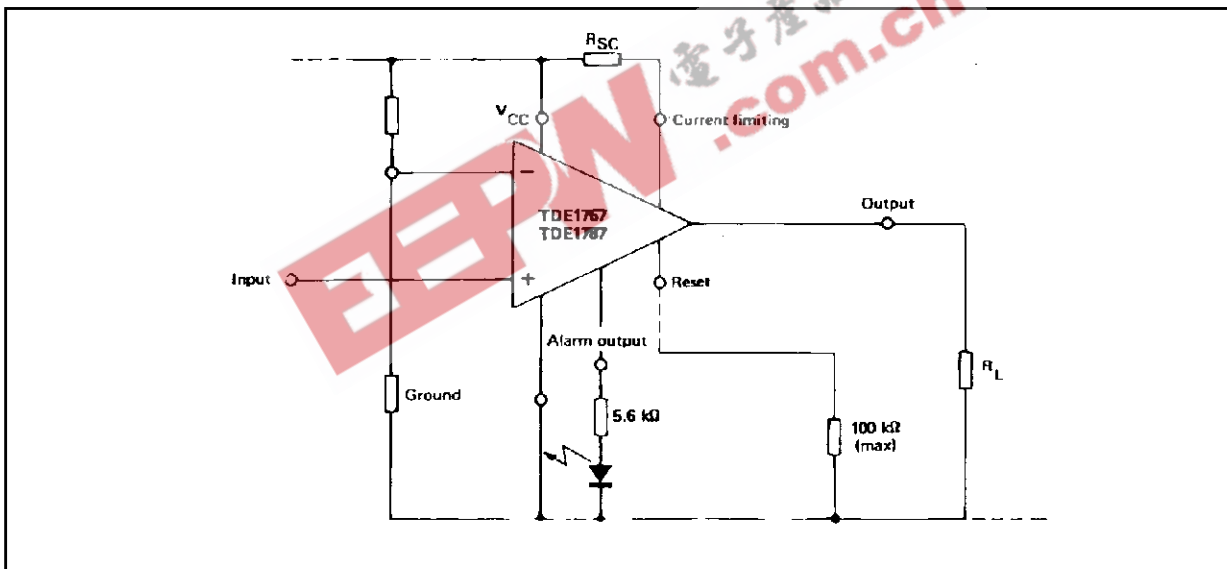

Figure 15. Common Reset.

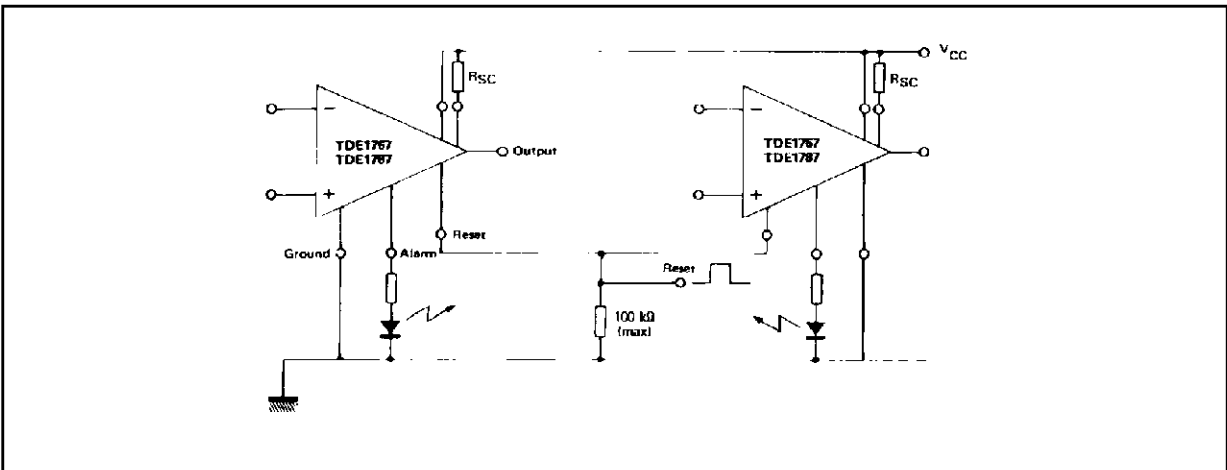
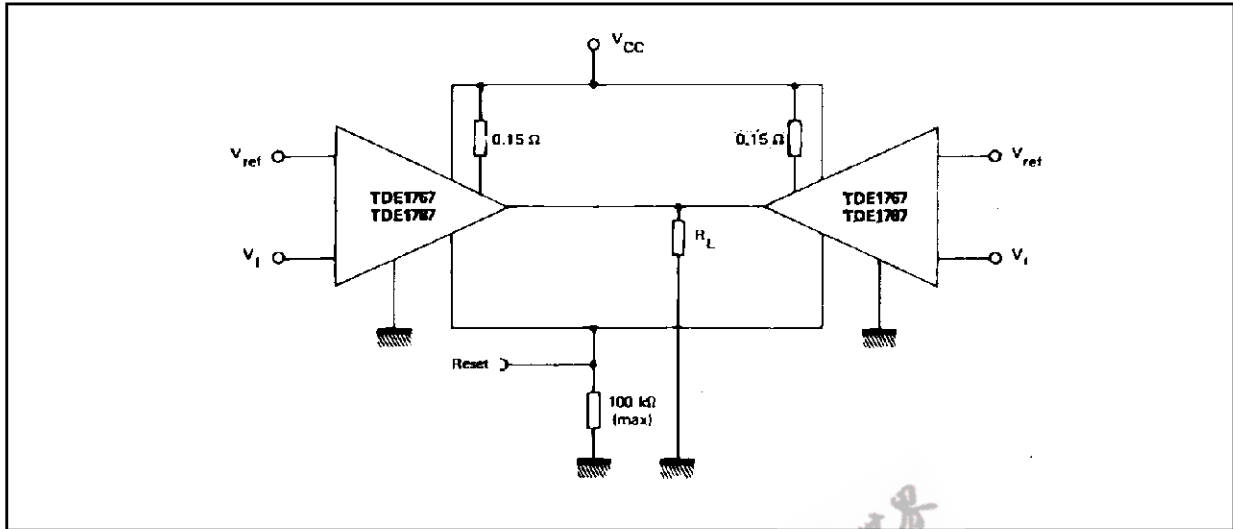

Figure 16. Parallel Driving of Loads Up to 1 A.



USING ALARM OUTPUT

Figure 17. Parallel Alarm Outputs.

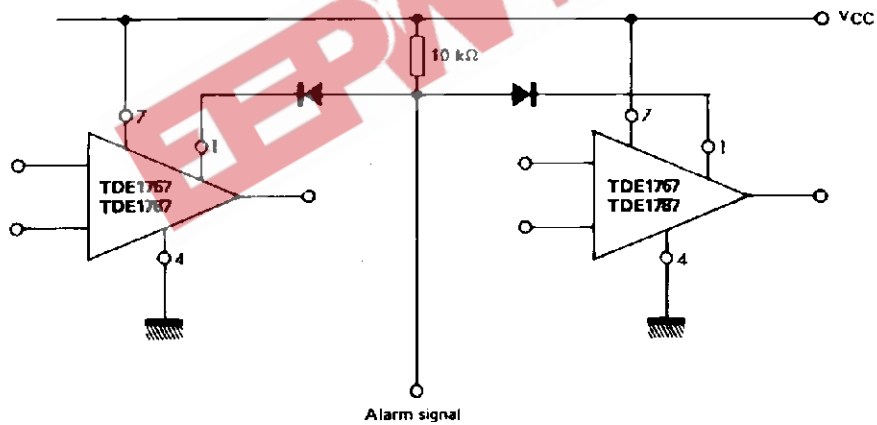

Figure 18. Led to VCC.

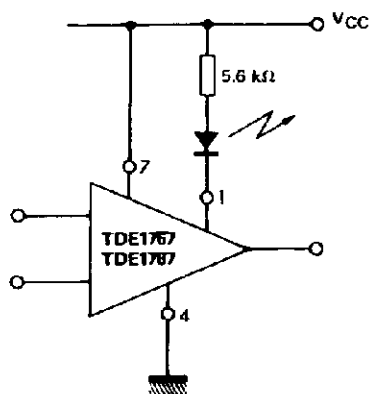
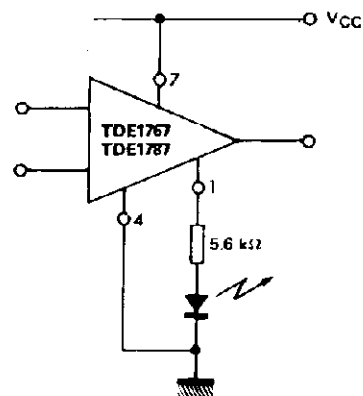

Figure 19. Led to Ground.



TDE1767,A-TDE1787,A

Figure 20. Interface between High voltage and Low Voltage System.

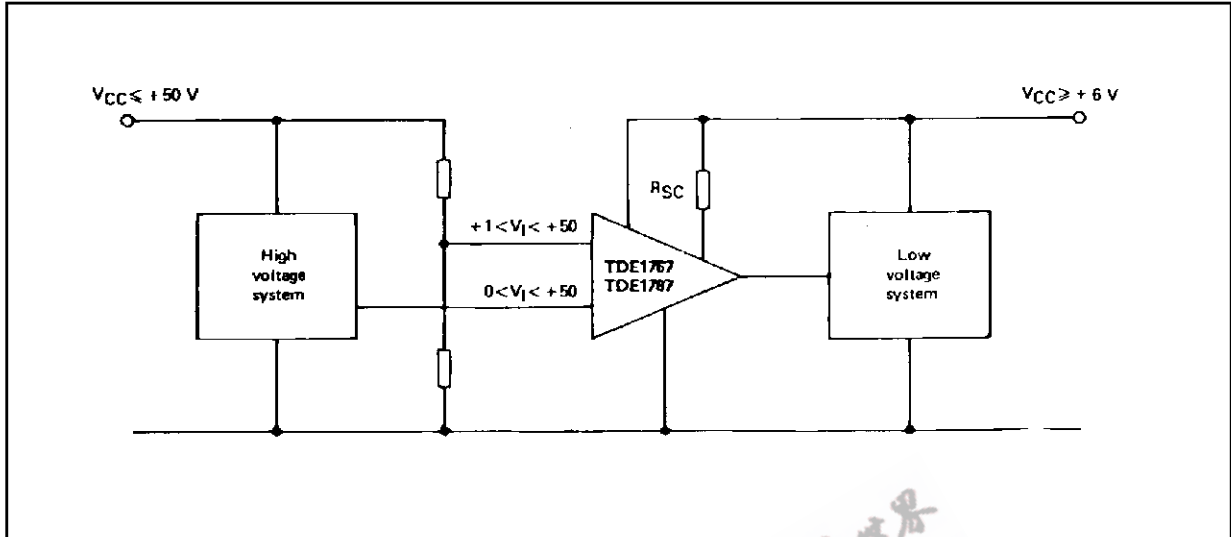
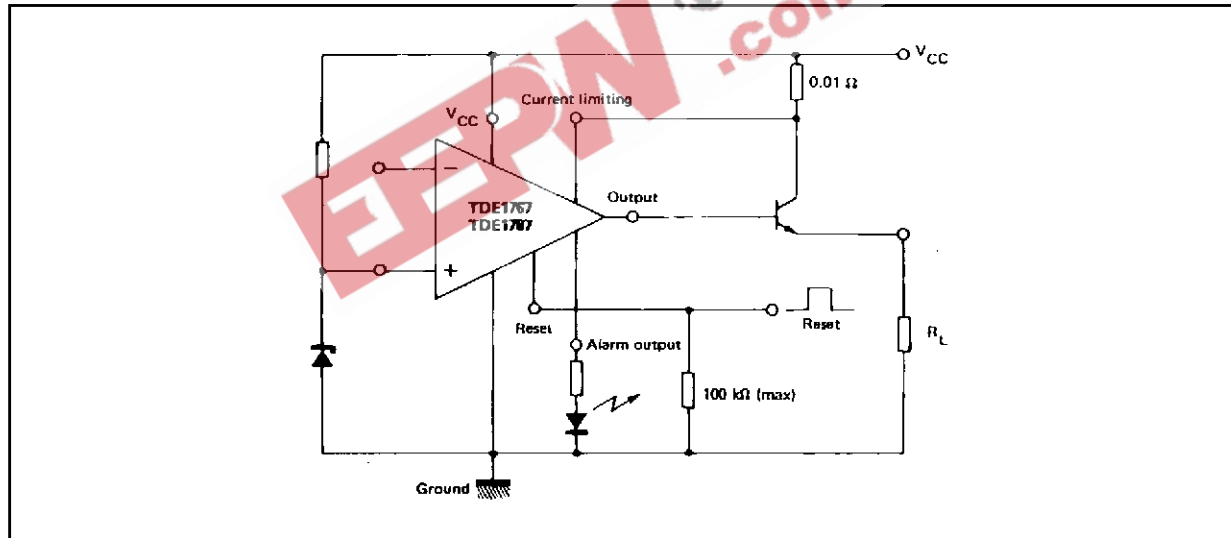
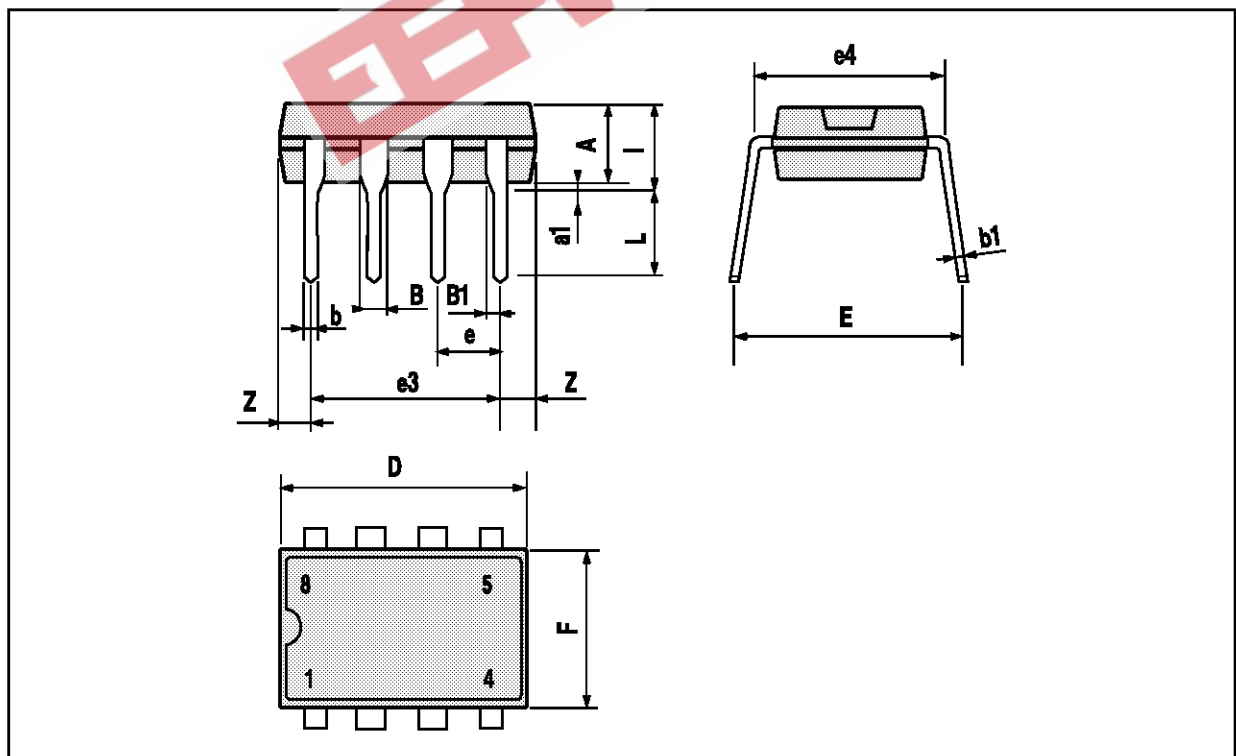

Figure 21. Increasing Current Up to 10 A.



MINIDIP PACKAGE MECHANICAL DATA

DIM.	mm			inch		
	MIN.	TYP.	MAX.	MIN.	TYP.	MAX.
A		3.32			0.131	
a1	0.51			0.020		
B	1.15		1.65	0.045		0.065
b	0.356		0.55	0.014		0.022
b1	0.204		0.304	0.008		0.012
D			10.92			0.430
E	7.95		9.75	0.313		0.384
e		2.54			0.100	
e3		7.62			0.300	
e4		7.62			0.300	
F			6.6			0.260
I			5.08			0.200
L	3.18		3.81	0.125		0.150
Z			1.52			0.060



EEPW 电子產品世界
.com.cn

Information furnished is believed to be accurate and reliable. However, SGS-THOMSON Microelectronics assumes no responsibility for the consequences of use of such information nor for any infringement of patents or other rights of third parties which may result from its use. No license is granted by implication or otherwise under any patent or patent rights of SGS-THOMSON Microelectronics. Specifications mentioned in this publication are subject to change without notice. This publication supersedes and replaces all information previously supplied. SGS-THOMSON Microelectronics products are not authorized for use as critical components in life support devices or systems without express written approval of SGS-THOMSON Microelectronics.

© 1994 SGS-THOMSON Microelectronics - All Rights Reserved

SGS-THOMSON Microelectronics GROUP OF COMPANIES

Australia - Brazil - France - Germany - Hong Kong - Italy - Japan - Korea - Malaysia - Malta - Morocco - The Netherlands - Singapore - Spain - Sweden - Switzerland - Taiwan - Thailand - United Kingdom - U.S.A.