

LOW COST, SINGLE TRIP POINT TEMPERATURE SENSOR

FEATURES

- Temperature Set Point Easily Programs with a Single External Resistor
- Operates with 2.7V Power Supply (TC624)
- TO-220 Package for Direct Mounting to Heatsink (TC622xAT) or Standard 8-Pin PDIP and SOIC
- Cost Effective

APPLICATIONS

- Power Supply Over-temperature Detection
- Consumer Electronics
- Fire/ Heat Detection
- UPS's, Amplifiers, Motors
- CPU Thermal Management in PC's

GENERAL DESCRIPTION

The TC622 and TC624 are programmable solid state temperature switches designed to replace mechanical switches in sensing and control applications. Both devices integrate the temperature sensor along with a voltage reference and all required detector circuitry to form a stand-alone temperature switch. The desired temperature set point is set by the user with a single external resistor.

Ambient temperature is sensed and compared to the programmed setpoint. The OUT and $\overline{\text{OUT}}$ outputs are driven to their active state when the measured temperature exceeds the programmed setpoint.

The TC622 has a power supply voltage range of 4.5V to 18.0V while the TC624 operates over a power supply range of 2.7V to 4.5V. Both devices are usable over a temperature range of -40°C to $+125^{\circ}\text{C}$ (TC622Vxx, TC624Vxx). Both devices feature low supply current making them suitable for many portable applications.

Eight-pin through-hole and surface mount packages are available. The TC622 is also offered in a 5-pin TO-220 package.

FUNCTIONAL BLOCK DIAGRAM

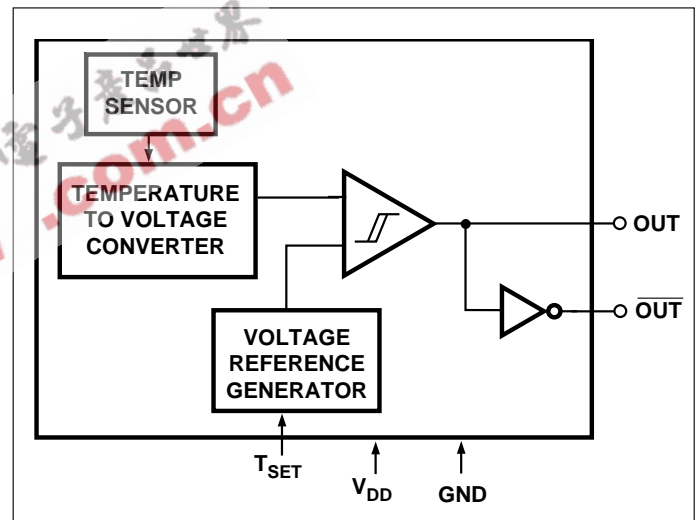

ORDERING INFORMATION

Part No.	Voltage Operation	Package	Ambient Temperature
TC622COA	4.5V to 18V	8-Pin SOIC	0°C to +70°C
TC622CPA	4.5V to 18V	8-Pin Plastic DIP	0°C to +70°C
TC622EAT	4.5V to 18V	5-Pin TO-220	-40°C to $+85^{\circ}\text{C}$
TC622EOA	4.5V to 18V	8-Pin SOIC	-40°C to $+85^{\circ}\text{C}$
TC622EPA	4.5V to 18V	8-Pin Plastic DIP	-40°C to $+85^{\circ}\text{C}$
TC622VAT	4.5V to 18V	5-Pin TO-220	-40°C to $+125^{\circ}\text{C}$
TC622VOA	4.5V to 18V	8-Pin SOIC	-40°C to $+125^{\circ}\text{C}$
TC622VPA	4.5V to 18V	8-Pin Plastic DIP	-40°C to $+125^{\circ}\text{C}$
TC624COA	2.7V to 4.5V	8-Pin SOIC	0°C to +70°C
TC624CPA	2.7V to 4.5V	8-Pin Plastic DIP	0°C to +70°C
TC624EOA	2.7V to 4.5V	8-Pin SOIC	-40°C to $+85^{\circ}\text{C}$
TC624EPA	2.7V to 4.5V	8-Pin Plastic DIP	-40°C to $+85^{\circ}\text{C}$
TC624VOA	2.7V to 4.5V	8-Pin SOIC	-40°C to $+125^{\circ}\text{C}$
TC624VPA	2.7V to 4.5V	8-Pin Plastic DIP	-40°C to $+125^{\circ}\text{C}$

LOW COST, SINGLE TRIP POINT TEMPERATURE SENSOR

TC622 TC624

ABSOLUTE MAXIMUM RATINGS*

Supply Voltage (TC622)	20V
(TC624)	5.5V
Input Voltage Any Input	(GND – 0.3V) to (V _{DD} +0.3V)
Operating Temperature	– 40°C to +125°C
C Version	0°C to +70°C
E Version	– 40°C to +85°C
V Version	– 40°C to +125°C
Maximum Junction Temperature	+150°C

Storage Temperature	– 65°C to +150°C
Lead Temperature (Soldering, 10 sec)	+300°C

*Stresses above those listed under "Absolute Maximum Ratings" may cause permanent damage to the device. These are stress ratings only and functional operation of the device at these or any other conditions above those indicated in the operation sections of the specifications is not implied. Exposure to absolute maximum rating conditions for extended periods may affect device reliability.

ELECTRICAL CHARACTERISTICS (Over Operating Temperature Range, unless otherwise specified.)

Parameter	Conditions	Min	Typ	Max	Unit
Supply Voltage Range	TC622	4.5	—	18	V
	TC624	2.7	—	4.5	
Supply Current	TC622 5.0V ≤ V _{DD} ≤ 18V	—	200	600	μA
	TC624 2.7V ≤ V _{DD} ≤ 4.5V	—	170	300	
V _{OH}	TC622 5.0V ≤ V _{DD} ≤ 18V, – 40°C ≤ T _A ≤ +125°C, I _{OH} = 250μA	0.90 x V _{DD}	—	—	V
	I _{OH} = 500μA	0.80 x V _{DD}	—	—	
V _{OL}	TC622 – 40°C ≤ T _A ≤ +85°C, I _{OL} = 500μA	—	—	0.15 x V _{DD}	V
	I _{OL} = 1mA	—	—	0.30 x V _{DD}	
	– 40°C ≤ T _A ≤ +125°C, I _{OL} = 1mA	—	—	0.35 x V _{DD}	
V _{OH}	TC624 2.7V ≤ V _{DD} ≤ 4.5V, – 40°C ≤ T _A ≤ +125°C, I _{OH} = 250μA	0.9 x V _{DD}	—	—	V
	I _{OH} = 500μA	0.8 x V _{DD}	—	—	
V _{OL}	TC624 – 40°C ≤ T _A ≤ +85°C, I _{OL} = 500μA	—	—	0.1 x V _{DD}	V
	I _{OL} = 1mA	—	—	0.2 x V _{DD}	
	– 40°C ≤ T _A ≤ +125°C, I _{OL} = 1mA	—	—	0.25 x V _{DD}	
Absolute Accuracy	TC622 T _{SET} = Programmed Temperature	T – 5	T ± 1	T + 5	°C
	TC624 T _{SET} = Programmed Temperature	T – 5	T ± 1	T + 5	
Trip Point Hysteresis	TC622	—	2	—	°C
	TC624	—	2	—	

DETAILED DESCRIPTION

The TC622 and TC624 are single point temperature detectors ideal for use in a wide variety of applications. When the temperature of the device exceeds the programmed temperature trip point, T_{SET}, the OUT and OUT outputs are driven into their active states. The desired trip-point temperature is programmed with a single external resistor connected between the T_{SET} input and V_{CC}. The relationship between the resistor value and the trip point temperature is given by the equation below.

For example, to program the device to trip at 50°C, the programming resistor is:

$$R_{TRIP} = 0.5997 \times ((50 + 273.15)^{2.1312}) = 133,652 \Omega$$

$$R_{TRIP} = 0.5997 \times T^{2.1312}$$

Where R_{trip} = Programming resistor value in Ohms
T = Desired trip temperature in degrees Kelvin.

LOW COST, SINGLE TRIP POINT TEMPERATURE SENSOR

TC622
TC624

Hysteresis

To prevent output "chattering" at the trip point temperature, the temperature detector in the TC622/624 has 2°C of hysteresis (See Figure 1).

The outputs are driven active when the temperature crosses the setpoint determined by the external resistor. As temperature declines below the setpoint, the hysteresis action will hold the outputs true until the temperature drops 2°C below the threshold.

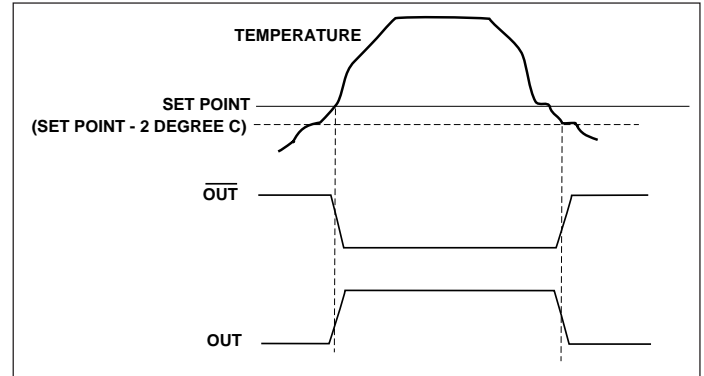

Figure 1. TC622/624 Hysteresis

PIN CONFIGURATIONS

