

DATA SHEET

EEPW 电子产品世界
.com.cn

TDA3856

Quasi-split sound processor for all standards

Product specification
File under Integrated Circuits, IC02

June 1994

Quasi-split sound processor for all standards

TDA3856

FEATURES

- Quasi-split sound processor for all standards e. g. B/G (FM sound) and L (AM sound)
- Automatic muting of the AF2 signal (at B/G) by the input level
- AM signal processing for L standard and switching over the audio signal
- Layout-compatible with TDA3858 (32 pins) and TDA3857 (20 pins).

GENERAL DESCRIPTION

Separate symmetrical IF inputs for FM or AM sound.

Gain controlled wideband IF amplifier, input select switch. AGC generation due to peak sync for FM or mean signal level for AM. Reference amplifier for the regeneration of the vision carrier. Optimized limiting amplifier for AM suppression in the regenerated vision carrier signal and 90° phase shifter. Intercarrier mixer for FM sound, output with low-pass filter. Separate signal processing for 5.5 and 5.74 MHz intercarriers. Wide supply voltage range, only 300 mW power dissipation at 5 V.

QUICK REFERENCE DATA

SYMBOL	PARAMETER	MIN.	TYP.	MAX.	UNIT
V_P	supply voltage (pin 21)	4.5	5	8.8	V
I_P	supply current	–	60	72	mA
$V_{i\text{ IF}}$	IF input sensitivity (–3 dB)	–	70	100	μV
$V_{o(\text{RMS})}$	audio output signal for FM (B/G)	–	1	–	V
$V_{o(\text{RMS})}$	audio output signal for AM (L)	–	0.6	–	V
THD	total harmonic distortion				
	for FM	–	0.5	–	%
	for AM	–	1	–	%
S/N (W)	weighted signal-to-noise ratio				
	for FM	–	68	–	dB
	for AM	–	56	–	dB

ORDERING INFORMATION

EXTENDED TYPE NUMBER	PACKAGE			
	PINS	PIN POSITION	MATERIAL	CODE
TDA3856	24	shrink DIL	plastic	SOT234 ⁽¹⁾
TDA3856T	24	SO	plastic	SOT137 ⁽²⁾

Note

1. SOT234-1; 1996 November 28.
2. SOT137-1; 1996 November 28.

Quasi-split sound processor for all standards

TDA3856

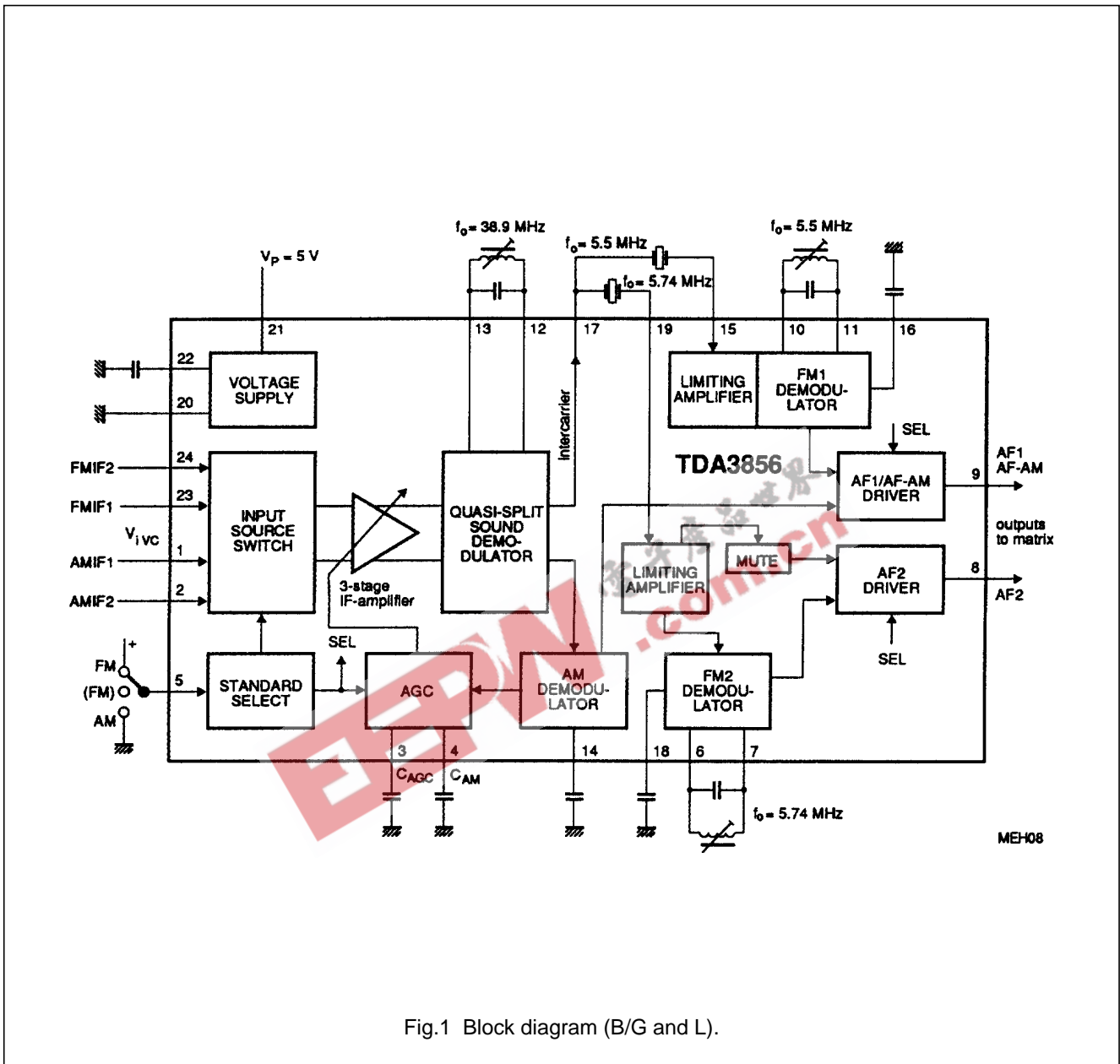

Fig.1 Block diagram (B/G and L).

Quasi-split sound processor for all standards

TDA3856

PINNING

SYMBOL	PIN	DESCRIPTION
AMIF1	1	AM IF difference input 1 for L standard (32.4 MHz)
AMIF2	2	AM IF difference input 2 for L standard (32.4 MHz)
C _{AGC}	3	charge capacitor for AGC (FM and AM)
C _{AM}	4	charge capacitor for AM AGC
MODE	5	3-state input for standard select
FM2R1	6	reference circuit for FM2 (5.74 MHz)
FM2R2	7	reference circuit for FM2 (5.74 MHz)
AF2	8	AF2 output (AF out of 5.74 MHz)
AF1	9	AF1 output (AF out of 5.5 MHz or AM)
FM1R1	10	reference circuit for FM1 (5.5 MHz)
FM1R2	11	reference circuit for FM1 (5.5 MHz)
VC-R1	12	reference circuit for the vision carrier (38.9 MHz)
VC-R2	13	reference circuit for the vision carrier (38.9 MHz)
C _{AFAM}	14	DC decoupling capacitor for AM demodulator (AF-AM)
FM1	15	intercarrier input for FM1 (5.5 MHz)
C _{AF1}	16	DC decoupling capacitor for FM1 demodulator (AF1)
ICO	17	intercarrier output signal (5.5/5.74 MHz)
C _{AF2}	18	DC decoupling capacitor for FM2 demodulator (AF2)
FM2I	19	intercarrier input for FM2 (5.74 MHz)
GND	20	ground (0 V)
V _P	21	+5 to +8 V supply voltage
C _{REF}	22	charge capacitor for reference voltage
FMIF1	23	IF difference input 1 for B/G standard (38.9 MHz)
FMIF2	24	IF difference input 2 for B/G standard (38.9 MHz)

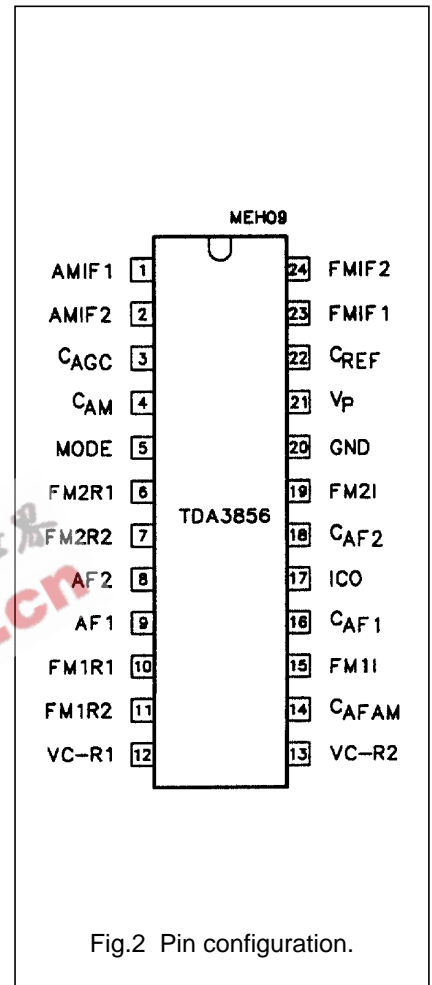

Quasi-split sound processor for all standards

TDA3856

FUNCTIONAL DESCRIPTION

The quasi-split sound processor is suitable for all standards.

Dependent on the voltage at pin 5 either FM mode (B/G) or AM mode (L) is selected.

B/G standard (FM mode)

Pins 23 and 24 are active, AGC detector uses peak sync level. Sound carrier SC1 (5.5 MHz) provides AF1, sound carrier SC2 (5.74 MHz) provides AF2.

Muting

With no sound carrier SC2 at pin 19, AF2 output is muted (in mid-position of the standard select switch FM mode without muting of AF2 is selected).

The mute circuit prevents false signal recognition in the stereo decoder at high IF signal levels when no second sound carrier exists (mono) and an AF signal is present in the identification signal frequency range.

With 1 mV at pin 19, under measurement conditions, AF2 is switched on (see limiting amplifier). Weak input signals at pins 23 and 24 generate noise at pin 19, which is present in the intercarrier signal and passes through the 5.74 MHz filter. Noise at pin 19 inhibits muting. No misinterpretation due to white noise occurs in the stereo decoder, when non-correlated noise masks the identification signal frequencies, which may be present in sustained tone signals. The stereo decoder remains switched to mono.

L standard (AM mode)

Pins 1 and 2 are active, AGC detector uses mean signal level. The audio signal from the AM demodulator is output on AF1, with AF2 output muted.

Sound carrier notch filter for an improved intercarrier buzz

The series capacitor C_s in the 38.9 MHz resonant circuit provides a notch at the sound carrier frequency in order to provide more attenuation for the sound carrier in the vision carrier reference channel. The ratio of parallel/series capacitor depends on the ratio of VC/SC frequency and has to be adapted to other TV transmission standards if necessary, according to the formula $C_s = C_P (f_{VC}/f_{SC})^2 - C_P$. The result is an improved intercarrier buzz (up to 10 dB improvement in sound channel 2 with 250 kHz video modulation for B/G stereo) or suppression of 350 kHz video modulated beat frequency in the digitally-modulated NICAM subcarrier.

Intercarrier buzz fine tuning with 250 kHz square wave video modulation

The picture carrier for quadrature demodulation in the intercarrier mixer is not exactly 90 degrees due to the shift variation in the integrated phase shift network. The tuning of the LC reference circuit to provide optimal video suppression at the intercarrier output is not the same as that to provide optimal intercarrier buzz suppression. In order to optimize the AF signal performance, a fine tuning for the optimal S/N at the sound channel 2 (from 5.74 MHz) may be performed with a 250 kHz square wave video modulation.

Measurements at the demodulators

For all signal-to-noise measurements the generator must meet the following specifications: phase modulation errors $< 0.5^\circ$ for B/W-jumps
intercarrier signal-to-noise ratio as measured with 'TV-demodulator AMF2' (weighted S/N) must be > 60 dB at 6 kHz sine wave modulation of the B/W-signal.
Signal-to-noise ratios are measured with $\Delta f = \pm 50$ kHz deviation and $f_{mod} = 1$ kHz; with a deviation of ± 30 kHz the S/N ratio is deteriorated by 4.5 dB.

Quasi-split sound processor for all standards

TDA3856

LIMITING VALUES

In accordance with the Absolute Maximum Rating System (IEC 134).

SYMBOL	PARAMETER	MIN.	MAX.	UNIT
V _{P1}	supply voltage (pin 21)	–	8.8	V
V _I	voltage (pins 1, 2, 5, 8, 9, 15, 17, 19, 23 and 24)	0	V _P	V
P _{tot}	total power dissipation	0	650	mW
T _{stg}	storage temperature	–25	+150	°C
T _{amb}	operating ambient temperature	0	+70	°C
V _{ESD}	electrostatic handling (note 1)			
	all pins except pins 1, 2, 23 and 24	±500	–	V
	pins 1, 2, 23 and 24	+400	–	V
		–500	–	V

Note to the Limiting Values

- Equivalent to discharging a 200 pF capacitor through a 0 Ω series resistor.

CHARACTERISTICS

V_P = 5 V and T_{amb} = +25 °C; measurements taken in Fig.3 with f_{vc} = 38.9 MHz, f_{SC1} = 33.4 MHz and f_{SC2} = 33.158 MHz. Vision carrier (VC) modulated with different video signals, modulation depth 100% (proportional to 10% residual carrier).

Vision carrier amplitude (RMS value) V_{iVC} = 10 mV; vision to sound carrier ratios are VC/SC1 = 13 dB and VC/SC2 = 20 dB. Sound carriers (SC1, SC2) modulated with f = 1 kHz and deviation Δf = 50 kHz, unless otherwise specified.

SYMBOL	PARAMETER	CONDITIONS	MIN.	TYP.	MAX.	UNIT
V _P	supply voltage (pin 21)		4.5	5	8.8	V
I _P	supply current (pin 21)		48	60	72	mA
IF source control (pin 5)						
V ₅	input voltage in order to obtain standards B/G (FM) with automatic muting	pin 5 connected	2.8	–	V _P	V
		pin 5 open-circuit	–	2.8	–	V
	B/G (FM) without muting	pin 5 connected or alternative measure: 22 kΩ to GND	1.3	–	2.3	V
	L (AM sound)	pin 5 connected	0	–	0.8	V
I ₅	input current	V ₅ = V _P	–	–	100	μA
		V ₅ = 0 V	–	–	–300	μA
IF input not activated (pins 1-2 or 23-24)						
R _I	input resistance		–	–	100	Ω
V _I	DC input voltage (pins 1, 2 or 23, 24)	LOW set internally	–	–	0.1	V
α ₁₂₋₁₃	crosstalk attenuation of IF input switch	note 1	50	56	–	dB
IF amplifier (pins 1-2 or 23-24)						
R _I	input resistance		1.8	2.2	–	kΩ
C _I	input capacitance		–	2.0	2.6	pF

Quasi-split sound processor for all standards

TDA3856

SYMBOL	PARAMETER	CONDITIONS	MIN.	TYP.	MAX.	UNIT
V_I	DC potential, voltage (pins 1, 2, 23, 24)		–	1.75	–	V
$V_{i\text{ IF (RMS)}}$	maximum input signal (RMS value)	$V_o = +1$ dB	70	100	–	mV
	input signal sensitivity B/G standard (RMS value, pins 32-24)	–3 dB intercarrier signal reduction at pin 17	–	70	100	μV
	input signal sensitivity L standard (RMS value, pins 1-2)	–3 dB intercarrier signal reduction at pin 9	–	70	100	μV
V_3	voltage for gain control (pin 3)		1.7	–	2.6	V
ΔG_V	IF gain control		60	63	–	dB
B	IF bandwidth	–3 dB	50	70	–	MHz
Resonance amplifier (pins 12-13)						
V_o (p-p)	vision carrier amplitude (peak-to-peak value)	$f_o = 38.9$ MHz	–	270	–	mV
R_{12-13}	operating resistance		–	4	–	k Ω
L	inductance	Figs 3 and 5	–	0.247	–	μH
C	capacitance		–	68	–	pF
Q_L	Q-factor of resonant circuit	$Q_o = 90$	–	40	–	
$V_{12, 13}$	DC voltage (pins 12 and 13)		–	$V_P - 1$	–	V
Inter-carrier mixer output (pin 17)						
V_o (RMS)	output signal for 5.5 MHz (RMS value)		71	95	125	mV
	output signal for 5.74 MHz (RMS value)		32	43	56	mV
B	IF bandwidth	–1 dB	6	8.5	–	MHz
		–3 dB	7	10	–	MHz
V_{VID}/V_{17}	residual video AM on intercarrier	note 2	–	3	10	%
$V_{VC(RMS)}$	residual vision carrier (RMS value)	1st/2nd harmonic (38.9/77.8 MHz)	–	0.5	1	mV
R_{17}	output resistance (emitter follower)	1 mA emitter current	–	30	–	Ω
I_o	allowable AC output current (pin 17)		–	–	± 0.7	mA
I_{17}	allowable DC output current		–	–	–2	mA
V_{17}	DC voltage	LC-circuit at pin 12, 13 adjusted to minimum video content at pin 17	1.5	1.75	2.0	V
Limiting amplifiers (pins 15 and 19)						
V_i (RMS)	minimum input signal (RMS value)	–3 dB AF signal	–	300	450	μV
	maximum input signal (RMS value)		200	–	–	mV
$R_{15, 19}$	input resistance		450	560	700	Ω
$V_{15, 19}$	DC voltage		–	0	–	V
V_i (RMS)	level detector threshold for no muting (RMS value, pin 19)	only 5.74 MHz channel	0.8	1.2	1.7	mV
ΔV_i	hysteresis of level detector		4	7	12	dB

Quasi-split sound processor for all standards

TDA3856

SYMBOL	PARAMETER	CONDITIONS	MIN.	TYP.	MAX.	UNIT
FM1 and FM2 demodulators						
Measurements with FM IF input signals of 5.5 MHz and 5.74 MHz with $V_{i\text{IF(RMS)}} = 10\text{ mV}$ ($f_{\text{mod}} = 1\text{ kHz}$, deviation $\Delta f = \pm 50\text{ kHz}$) at pins 15 and 19 without ceramic filters, $R_s = 50\ \Omega$. De-emphasis 50 μs and $V_5 = V_P$ (B/G standard). Q_L -factor = 11 for resonant circuits at pins 6-7 and 10-11 (including IC).						
$V_{IC(RMS)}$	intercarrier signals (RMS values, pins 6-7 and 10-11)		–	100	–	mV
V	DC voltage (pins 6, 7, 10 and 11)		–	1.8	–	V
$V_{O(RMS)}$	AF output signals (RMS values, pins 8 and 9)		0.84	0.95	1.07	V
ΔV_o	difference of AF signals between channels (pins 8 and 9)		–	–	1	dB
$R_{8,9}$	output resistance		75	100	130	Ω
$V_{8,9}$	DC voltage		1.8	2.1	2.4	V
$I_{8,9(M)}$	allowed AC current of emitter output (peak value)	note 3	–	–	± 1.5	mA
$I_{8,9}$	maximum allowed DC output current		–	–	–2	mA
THD	total harmonic distortion		–	0.5	1.0	%
$V_{O(RMS)}$	AF output signal (RMS value)	THD = 1.5%	1.25	–	–	V
α_{AM}	AM suppression	1 kHz; $m = 0.3$	48	54	–	dB
S/N(W)	weighted signal-to-noise ratio	CCIR468-3	64	68	–	dB
B	AF bandwidth (–3 dB)					
	lower limit		–	–	20	Hz
	upper limit		100	–	–	kHz
α_{CR}	crosstalk attenuation (pins 9-8)		60	70	–	dB
$V_{16,18}$	DC voltage (pins 16 and 18)		–	1.8	–	V
AM demodulator $V_5 = 0\text{ V}$ (AM mode)						
input signals at pins 1-2: SC = 32.4 MHz; $f_{\text{mod}} = 1\text{ kHz}$; $m = 0.8$; $V_{i\text{AM(RMS)}} = 10\text{ mV}$						
$V_{O(RMS)}$	AF output signal at pin 9 (RMS value)		530	600	675	mV
R_9	output resistance (pin 9)		75	100	130	Ω
$I_{O(M)}$	maximum AC output current (peak value)	note 3	–	–	± 1.5	mA
I_9	maximum DC output current		–	–	–2	mA
V_9	DC voltage		1.8	2.1	2.4	V
THD	total harmonic distortion	Fig.4	–	1	2	%
S/N(W)	weighted signal-to-noise ratio	CCIR468-3	50	56	–	dB
B	AF bandwidth (–3 dB)					
	lower limit		–	–	20	Hz
	upper limit		100	–	–	kHz
V_{14}	DC voltage (pin 14)		–	2	–	V

Quasi-split sound processor for all standards

TDA3856

SYMBOL	PARAMETER	CONDITIONS	MIN.	TYP.	MAX.	UNIT
AF signal switches						
input signals: AM carrier into pin 1, 2		see part AM demodulator				
FM intercarrier into pin 15		see part FM demodulator				
no signal in pin 19 (AF2)						
the output signals are related to the signals described in the demodulator parts.						
V_o/V_{omute}	AF2 mute attenuation (pin 8)	B/G mode; $V_5 = V_P$	70	–	–	dB
V_{oAM}/V_{oFM}	AF1 FM signal (pin 9) attenuation of unwanted FM signal	L mode; $V_5 = 0$; FM: modulated; AM: unmodulated	70	–	–	dB
V_{oFM}/V_{oAM}	AF1 AM signal (pin 9) attenuation of unwanted AM signal	B/G mode; $V_5 = V_P$; FM: unmodulated; AM: modulated	70	–	–	dB
$dV_{8,9}$	DC jump at the AF outputs	switching to FM or AM sound or Mute	–	5	25	mV
AF performance for FM operation (standard B/G)						
input signals: B/G IF input signal (pin 23, 24)						
unmodulated sound carriers						
different video modulation (100%)						
the output signals are related to the signals described in the demodulator parts.						
(S+N)/N(W)	weighted signal-to-noise ratio	CCIR468-3; de-emphasis 50 μ s				
	black picture	$f_i = 5.5$ MHz	59	63	–	dB
	2T/20T pulses with white bar	$f_i = 5.5$ MHz	57	61	–	dB
	6 kHz sine wave, B/W-modulated	$f_i = 5.5$ MHz	52	56	–	dB
	250 kHz square wave, B/W-modulated	$f_i = 5.5$ MHz	50	54	–	dB
	black picture	$f_i = 5.742$ MHz	57	61	–	dB
	2T/20T pulses with white bar	$f_i = 5.742$ MHz	55	59	–	dB
	6 kHz sine wave, B/W-modulated	$f_i = 5.742$ MHz	50	54	–	dB
	250 kHz square wave, B/W-modulated	$f_i = 5.742$ MHz	48	52	–	dB
Ripple rejection of the AF outputs (B/G and L standard)						
RR	ripple rejection $V_{ripple\ on\ V_P} / V_{ripple\ on\ V_{out}}$	$V_{R(p-p)} = 200$ mV; $f_R = 70$ Hz	30	40	–	dB

Notes to the characteristics

- Crosstalk attenuation of IF input switch, measured at $R_{12-13} = 470\ \Omega$ (instead of LC circuit); input signal $V_i (RMS) = 20$ mV (pins 23-24). AGC voltage V_3 set to a value to achieve $V_o (RMS) = 20$ mV (pins 12-13). After switching ($V_5 = 0$ V) measure attenuation.
IF coupling with OFWG3203 and OFWL9350 (Siemens).
- Spurious intercarrier AM: $m = (A - B)/A$ (A = signal at sync; B = signal with 100% picture modulation).
- For larger current: $R_L > 2.2$ k Ω (pin 8 or 9 to GND) in order to increase the bias current of the output emitter follower.

Quasi-split sound processor for all standards

TDA3856

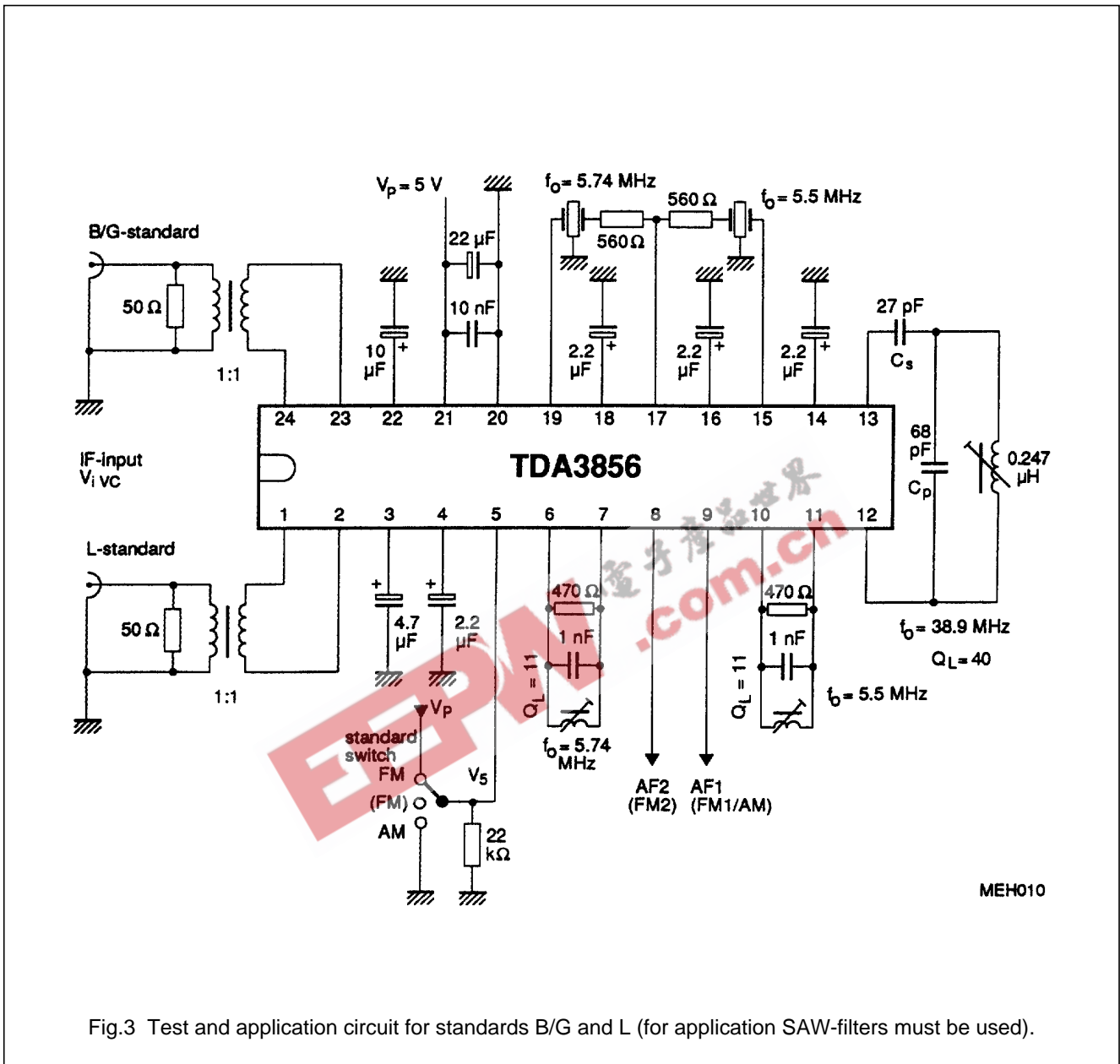

Fig.3 Test and application circuit for standards B/G and L (for application SAW-filters must be used).

Quasi-split sound processor for all standards

TDA3856

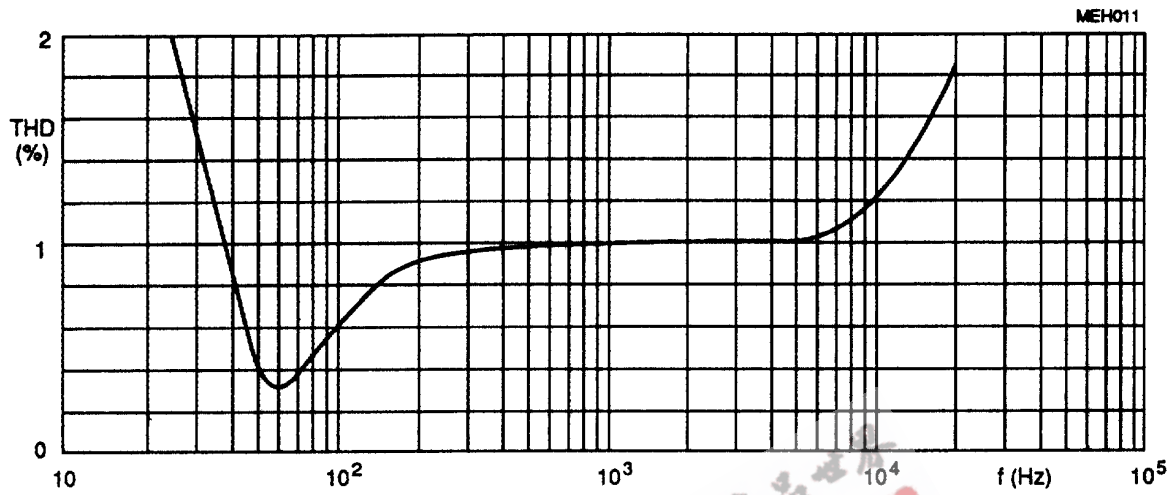
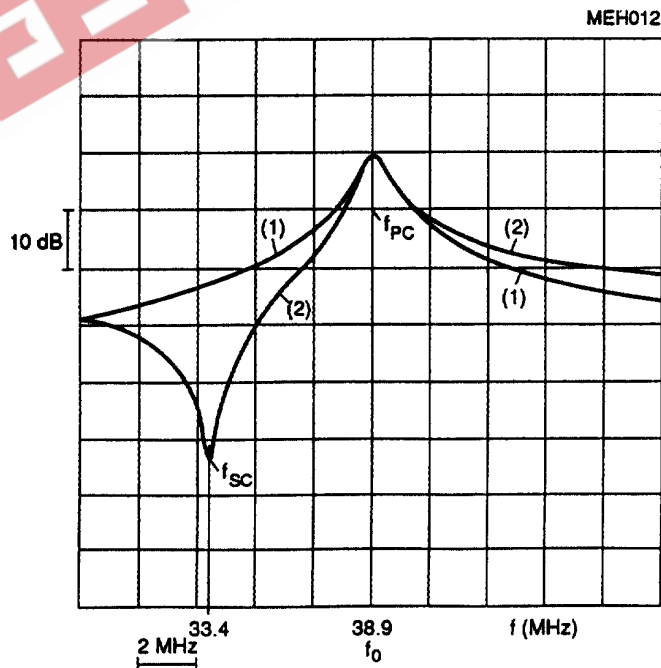

Fig.4 Total harmonic distortion (THD) as function of audio frequency at AM standard ($V_5 = 0$).



- (1) simple resonant circuit
- (2) resonant circuit with $C_P = 68 \text{ pF}$

$C_S = C_P (f_{VC}/f_{SC})^2 - C_P$
 $C_S = 27 \text{ pF}$ (see Fig.3)

Fig.5 Frequency response of the 38.9 MHz reference circuit.

Quasi-split sound processor for all standards

TDA3856

APPLICATION INFORMATION

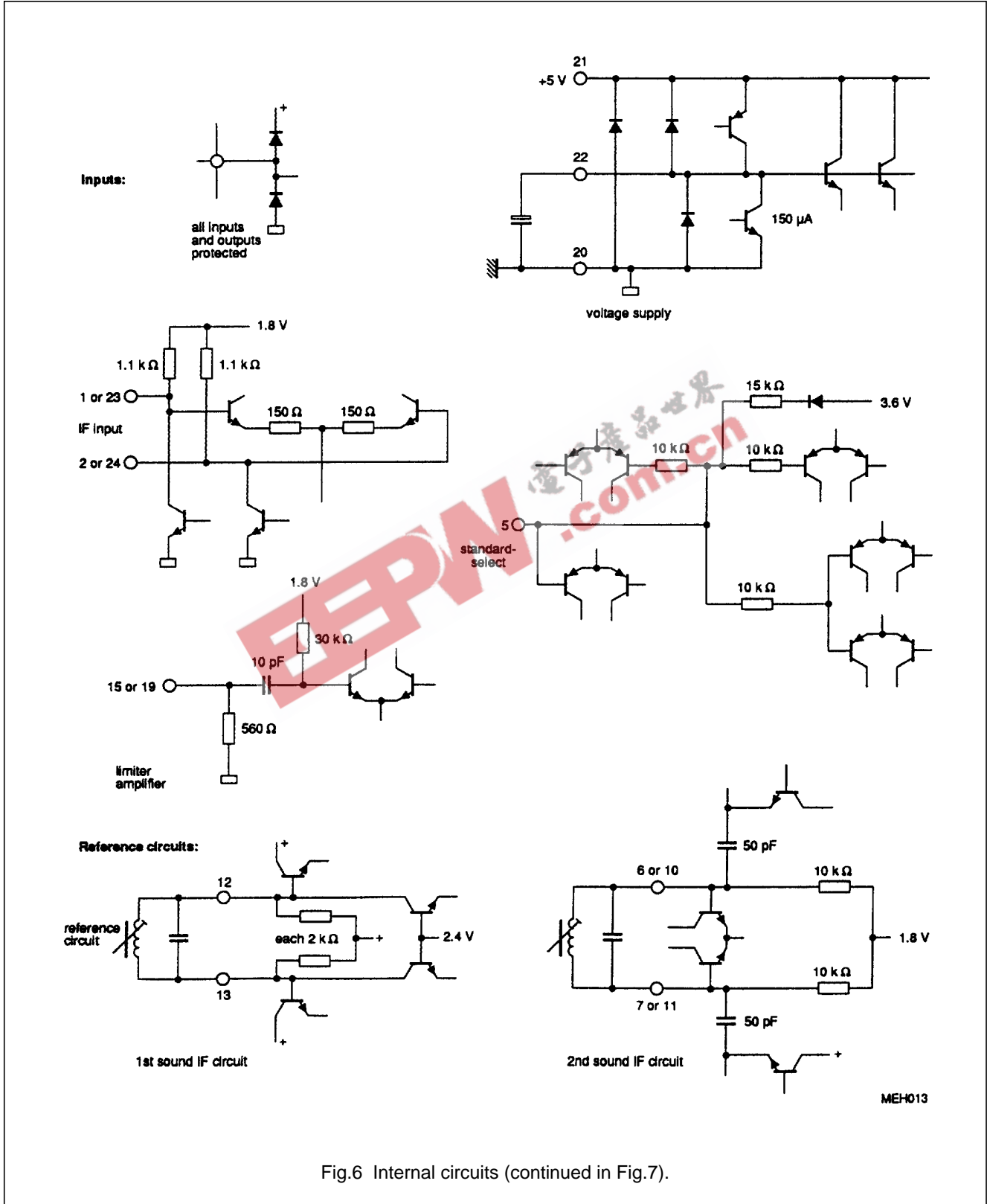
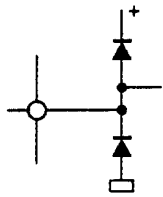

Fig.6 Internal circuits (continued in Fig.7).

Quasi-split sound processor for all standards

TDA3856

Driver outputs and decouplings:



all inputs and outputs protected

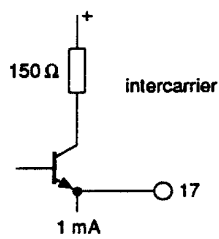

intercarrier

1 mA

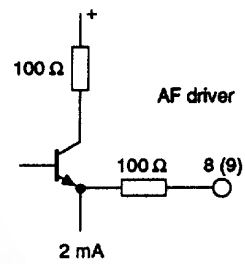

AF driver

2 mA

Capacitor pins:

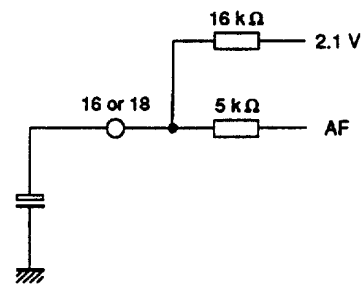
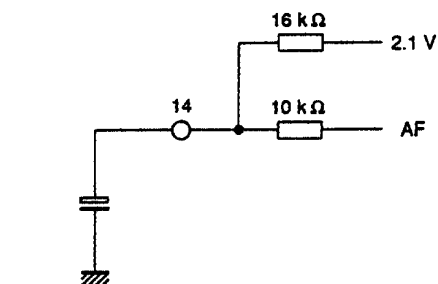
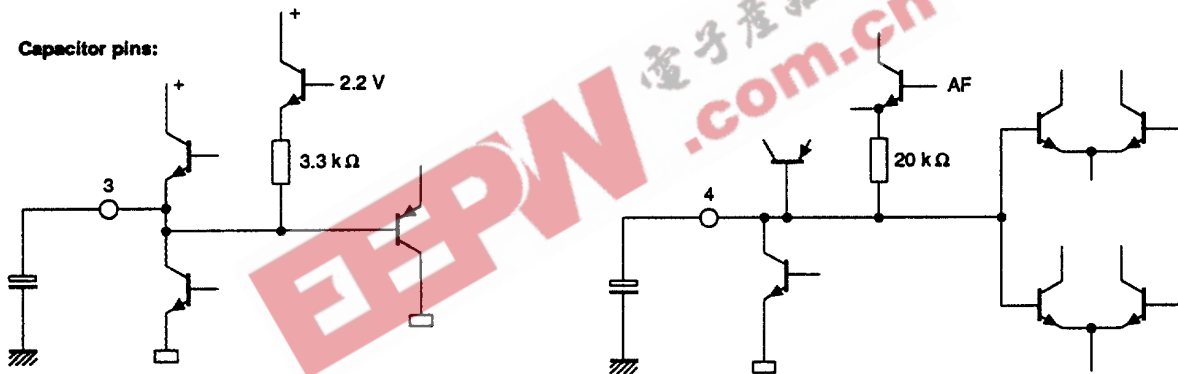

MEH014

Fig.7 Internal circuits (continued from Fig.6).

Quasi-split sound processor for all standards

TDA3856

PACKAGE OUTLINES

SDIP24: plastic shrink dual in-line package; 24 leads (400 mil)

SOT234-1

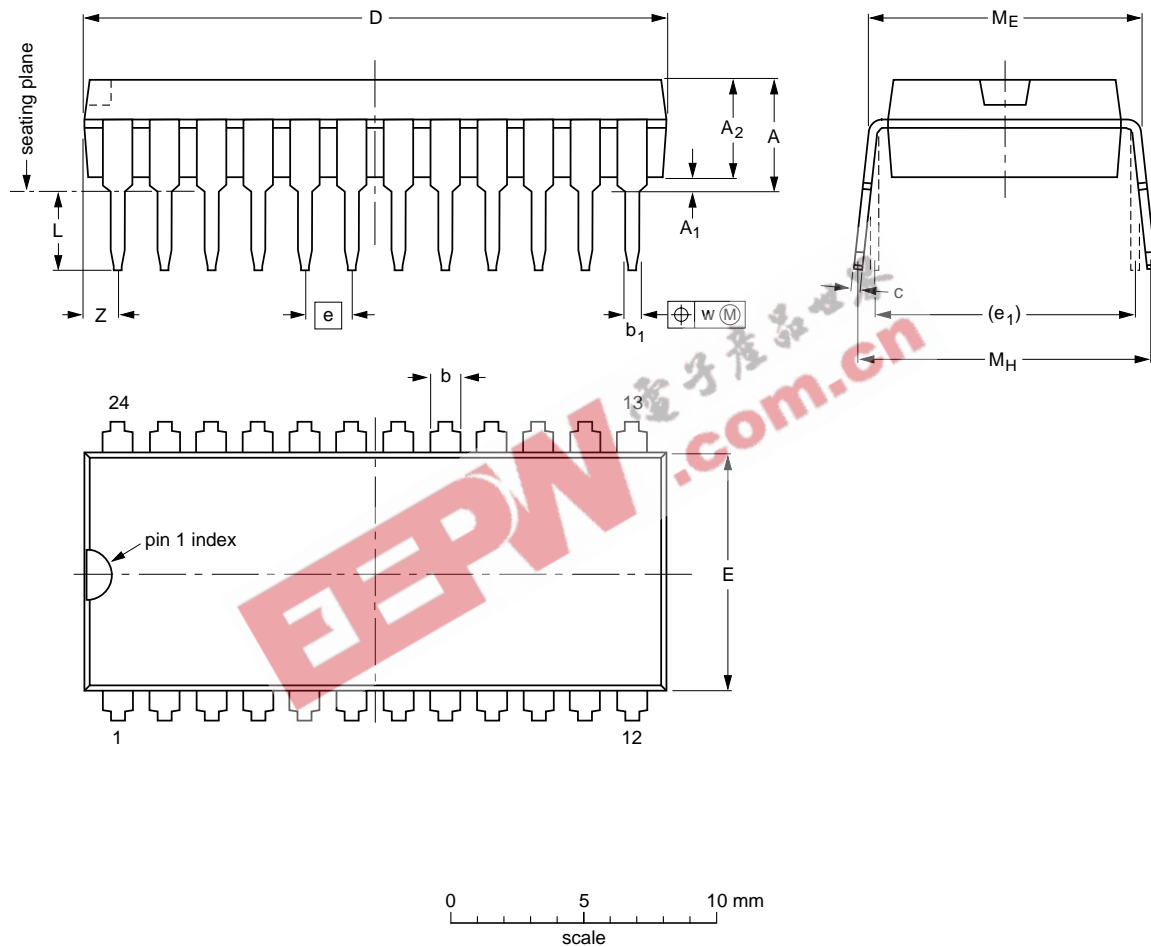

DIMENSIONS (mm are the original dimensions)

UNIT	A max.	A ₁ min.	A ₂ max.	b	b ₁	c	D ⁽¹⁾	E ⁽¹⁾	e	e ₁	L	M _E	M _H	w	Z ⁽¹⁾ max.
mm	4.7	0.51	3.8	1.3 0.8	0.53 0.40	0.32 0.23	22.3 21.4	9.1 8.7	1.778	10.16	3.2 2.8	10.7 10.2	12.2 10.5	0.18	1.6

Note

1. Plastic or metal protrusions of 0.25 mm maximum per side are not included.

OUTLINE VERSION	REFERENCES				EUROPEAN PROJECTION	ISSUE DATE
	IEC	JEDEC	EIAJ			
SOT234-1						92-11-17 95-02-04

Quasi-split sound processor for all standards

TDA3856

SO24: plastic small outline package; 24 leads; body width 7.5 mm

SOT137-1

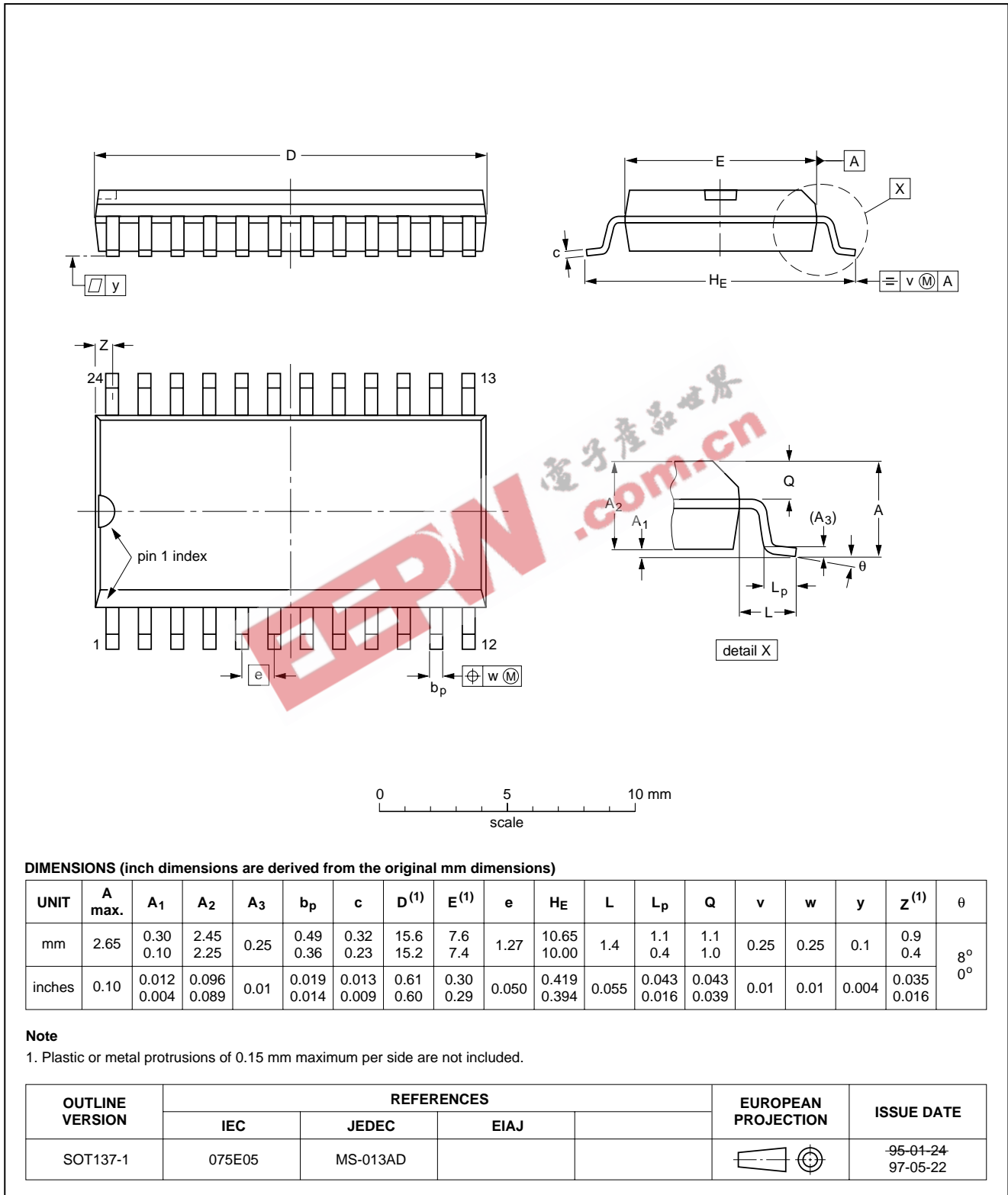

Quasi-split sound processor for all standards

TDA3856

SOLDERING

Introduction

There is no soldering method that is ideal for all IC packages. Wave soldering is often preferred when through-hole and surface mounted components are mixed on one printed-circuit board. However, wave soldering is not always suitable for surface mounted ICs, or for printed-circuits with high population densities. In these situations reflow soldering is often used.

This text gives a very brief insight to a complex technology. A more in-depth account of soldering ICs can be found in our "IC Package Databook" (order code 9398 652 90011).

SDIP

SOLDERING BY DIPPING OR BY WAVE

The maximum permissible temperature of the solder is 260 °C; solder at this temperature must not be in contact with the joint for more than 5 seconds. The total contact time of successive solder waves must not exceed 5 seconds.

The device may be mounted up to the seating plane, but the temperature of the plastic body must not exceed the specified maximum storage temperature ($T_{stg\ max}$). If the printed-circuit board has been pre-heated, forced cooling may be necessary immediately after soldering to keep the temperature within the permissible limit.

REPAIRING SOLDERED JOINTS

Apply a low voltage soldering iron (less than 24 V) to the lead(s) of the package, below the seating plane or not more than 2 mm above it. If the temperature of the soldering iron bit is less than 300 °C it may remain in contact for up to 10 seconds. If the bit temperature is between 300 and 400 °C, contact may be up to 5 seconds.

SO

REFLOW SOLDERING

Reflow soldering techniques are suitable for all SO packages.

Reflow soldering requires solder paste (a suspension of fine solder particles, flux and binding agent) to be applied to the printed-circuit board by screen printing, stencilling or pressure-syringe dispensing before package placement.

Several techniques exist for reflowing; for example, thermal conduction by heated belt. Dwell times vary between 50 and 300 seconds depending on heating method. Typical reflow temperatures range from 215 to 250 °C.

Preheating is necessary to dry the paste and evaporate the binding agent. Preheating duration: 45 minutes at 45 °C.

WAVE SOLDERING

Wave soldering techniques can be used for all SO packages if the following conditions are observed:

- A double-wave (a turbulent wave with high upward pressure followed by a smooth laminar wave) soldering technique should be used.
- The longitudinal axis of the package footprint must be parallel to the solder flow.
- The package footprint must incorporate solder thieves at the downstream end.

During placement and before soldering, the package must be fixed with a droplet of adhesive. The adhesive can be applied by screen printing, pin transfer or syringe dispensing. The package can be soldered after the adhesive is cured.

Maximum permissible solder temperature is 260 °C, and maximum duration of package immersion in solder is 10 seconds, if cooled to less than 150 °C within 6 seconds. Typical dwell time is 4 seconds at 250 °C.

A mildly-activated flux will eliminate the need for removal of corrosive residues in most applications.

REPAIRING SOLDERED JOINTS

Fix the component by first soldering two diagonally-opposite end leads. Use only a low voltage soldering iron (less than 24 V) applied to the flat part of the lead. Contact time must be limited to 10 seconds at up to 300 °C. When using a dedicated tool, all other leads can be soldered in one operation within 2 to 5 seconds between 270 and 320 °C.

Quasi-split sound processor for all standards

TDA3856

DEFINITIONS

Data sheet status	
Objective specification	This data sheet contains target or goal specifications for product development.
Preliminary specification	This data sheet contains preliminary data; supplementary data may be published later.
Product specification	This data sheet contains final product specifications.
Limiting values	
Limiting values given are in accordance with the Absolute Maximum Rating System (IEC 134). Stress above one or more of the limiting values may cause permanent damage to the device. These are stress ratings only and operation of the device at these or at any other conditions above those given in the Characteristics sections of the specification is not implied. Exposure to limiting values for extended periods may affect device reliability.	
Application information	
Where application information is given, it is advisory and does not form part of the specification.	

LIFE SUPPORT APPLICATIONS

These products are not designed for use in life support appliances, devices, or systems where malfunction of these products can reasonably be expected to result in personal injury. Philips customers using or selling these products for use in such applications do so at their own risk and agree to fully indemnify Philips for any damages resulting from such improper use or sale.

EEPW.com.cn