

The TDA2822M is a monolithic integrated circuit in 8 lead Minidip package. It is intended for use as dual audio power amplifier in portable cassette player and radios.

Features

- Supply Voltage Down to 1.8V
- Low Crossover Distorsion
- Low Quiescent Current
- Bridge or Stereo Configuration

8-DIP



1.OUTPUT(1)	5.INPUT(2)
2.SUPPLY VOLTAGE	6.INPUT(2)
3.OUTPUT(2)	7.INPUT(1)
4.GROUND	8.INPUT(1)

Absolute Maximum Ratings

Symbol	Parameter	Value	Unite
Vs	Supply Voltage	16	V
Io	Peak Output Current	1	A
Ptot	Total Power Dissipation at Tamb=50°C	1	W
	Tcase=50°C	1.4	W
Tstg,Tj	Storage and Junction Temperature	-40,+150	°C

Thermal Data

Symbol	Parameter	Value	Unite
Rthj-amb	Thermal Resistance Junction-ambient Max.	100	°C/W
Rthj-case	Thermal Resistance Junction-pin(4) Max.	70	°C/W

Electrical Characteristics ($V_S=6V, T_{amb}=25^\circ C$, unless otherwise specified)

Symbol	Parameter	Test Conditions	Min.	Typ.	Max.	Unit
STEREO (test circuit of Figure 1)						
V_S	Supply Voltage		1.8		15	V
V_O	Quiescent Output Voltage	$V_S=3V$		2.7 1.2		V
I_D	Quiescent Drain Current			6	9	mA
I_B	Input Bias Current			100		nA
P_O	Output Power (each channel) ($f=1KHz, d=10\%$)	$R_L=32\Omega$ $V_S=9V$ $V_S=6V$ $V_S=4.5V$ $V_S=3V$ $V_S=2V$ $R_L=16\Omega$ $V_S=6V$ $R_L=8\Omega$ $V_S=9V$ $V_S=6V$ $R_L=4\Omega$ $V_S=6V$ $V_S=4.5V$ $V_S=3V$	90 15 170 300 450	300 120 60 20 5 220 1000 380 650 320 110		mW
d	Distortion ($f=1KHz$)	$R_L=32\Omega$ $P_O=40mW$ $R_L=16\Omega$ $P_O=75mW$ $R_L=8\Omega$ $P_O=150mW$		0.2 0.2 0.2		%
G_V	Close Loop Voltage Gain	$f=1KHz$	36	39	41	dB
ΔG_V	Channel Balance				± 1	dB
R_i	Input Resistance	$f=1KHz$	100			$K\Omega$
e_N	Total Input Noise	$R_S=10K\Omega$ B=Curve A B=22Hz to 22KHz		2 2.5		μV μV
SVR	Supply Voltage Rejection	$f=100Hz, C1=C2=100\mu F$		24	30	dB
C_S	Channel Separation	$f=1KHz$			50	dB
BRIDGE (test circuit of Figure 2)						
V_S	Supply Voltage		1.8		15	V
I_D	Quiescent Drain Current	$R_L=\infty$				
V_{OS}	Output Offset Voltage (between the outputs)	$R_L=8\Omega$				
I_B	Input Bias Current					
P_O	Output Power	$R_L=32\Omega$ $V_S=9V$ $V_S=6V$ $V_S=4.5V$ $V_S=3V$ $V_S=2V$ $R_L=16\Omega$ $V_S=9V$ $V_S=6V$ $V_S=3V$ $R_L=8\Omega$ $V_S=6V$ $V_S=4.5V$ $V_S=3V$ $R_L=4\Omega$ $V_S=4.5V$ $V_S=3V$ $V_S=2V$	320 50 900 200	1000 400 200 65 8 2000 800 120 1350 700 220 1000 350 80		mW
d	Output Power ($f=1KHz, d=10\%$)	$P_O=0.5W, R_L=8\Omega, f=1KHz$		0.2		%
G_V	Closed Loop Voltage Gain	$f=1KHz$		39		dB
R_i	Input Resistance	$f=1KHz$	100			$K\Omega$
e_N	Total Input Noise	$R_S=10K\Omega$ B=Curve A B=22Hz to 22KHz		2.5 3		μV μV
SVR	Supply Voltage Rejection	$f=100Hz$		40		dB
B	Power Bandwidth (-3dB)	$R_L=8\Omega, P_O=1W$		120		KHz

Schematic Diagram

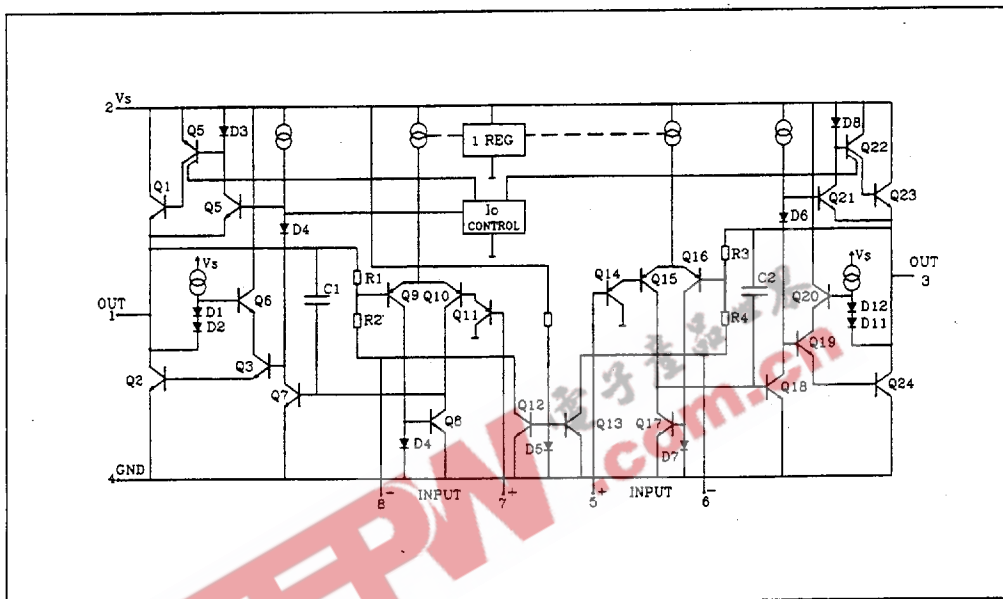

Figure 1: Test Circuit (Stereo)

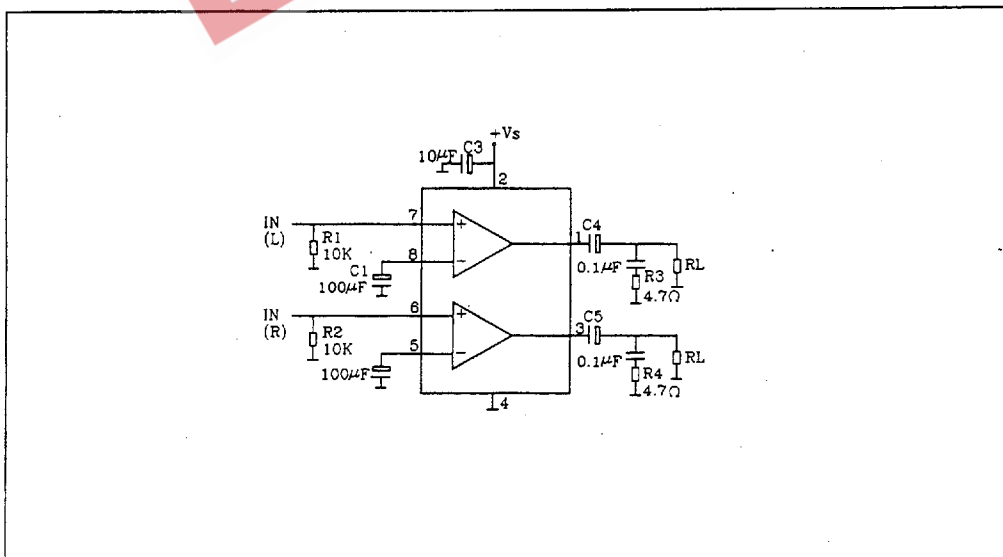

Figure 2. Test Circuit (Bridge)

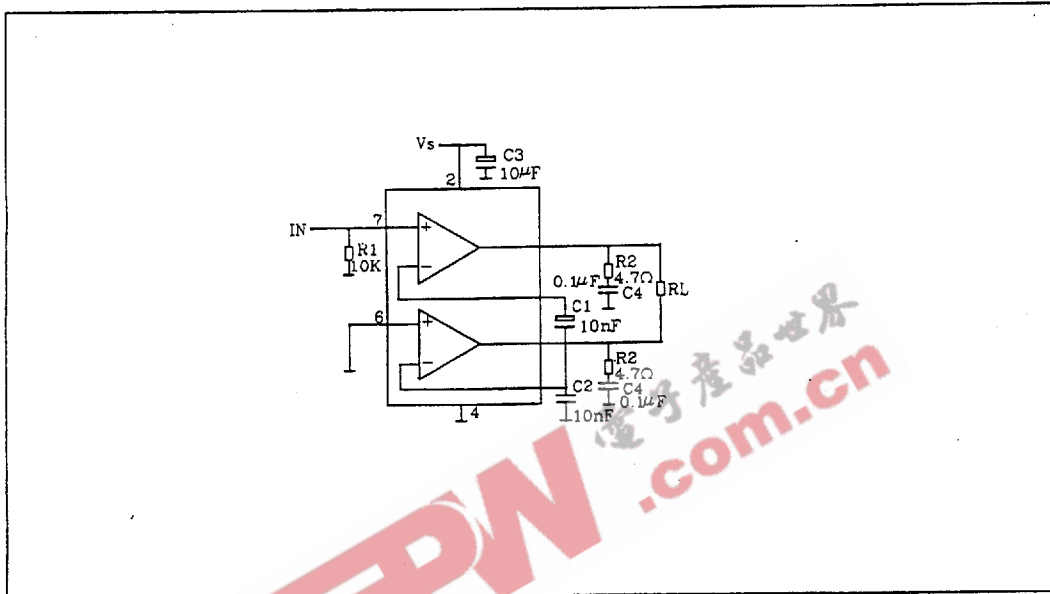

Figure 3. Typical Application in Portable Players

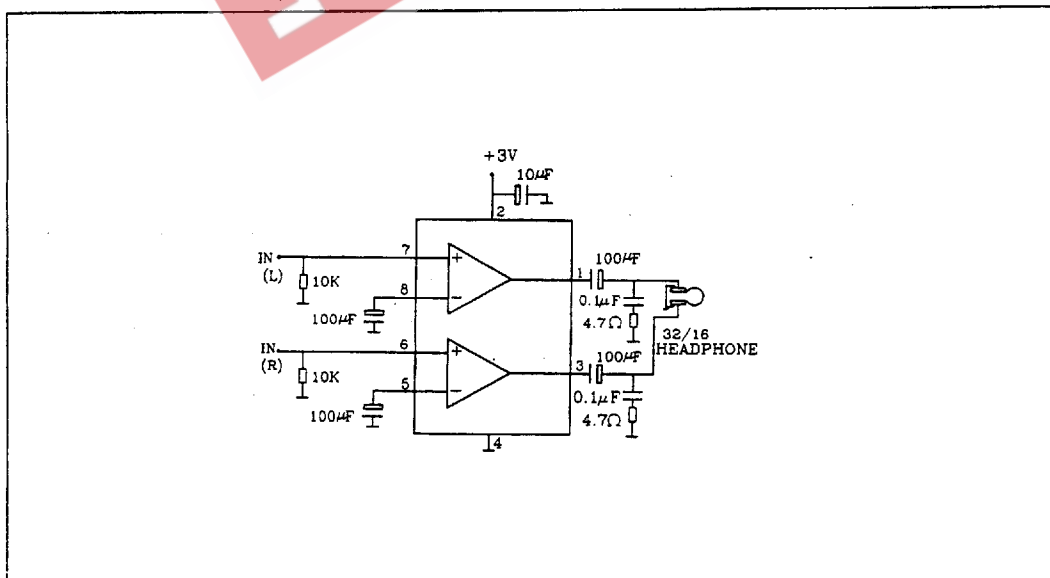

Figure 4. Application in Portable Radio Receivers

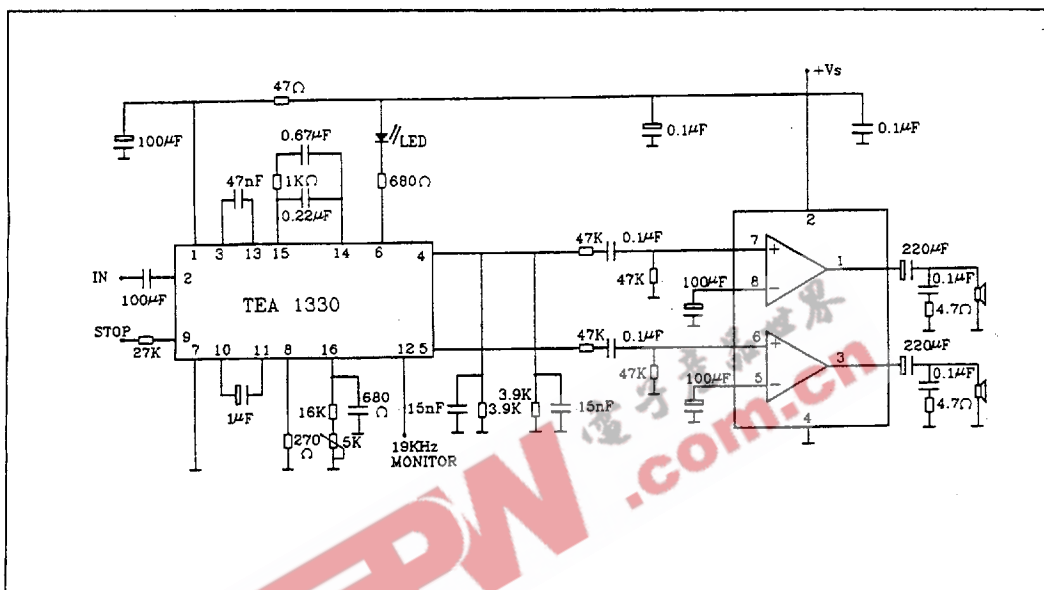

Figure 5. Portable Radio Cassette Players

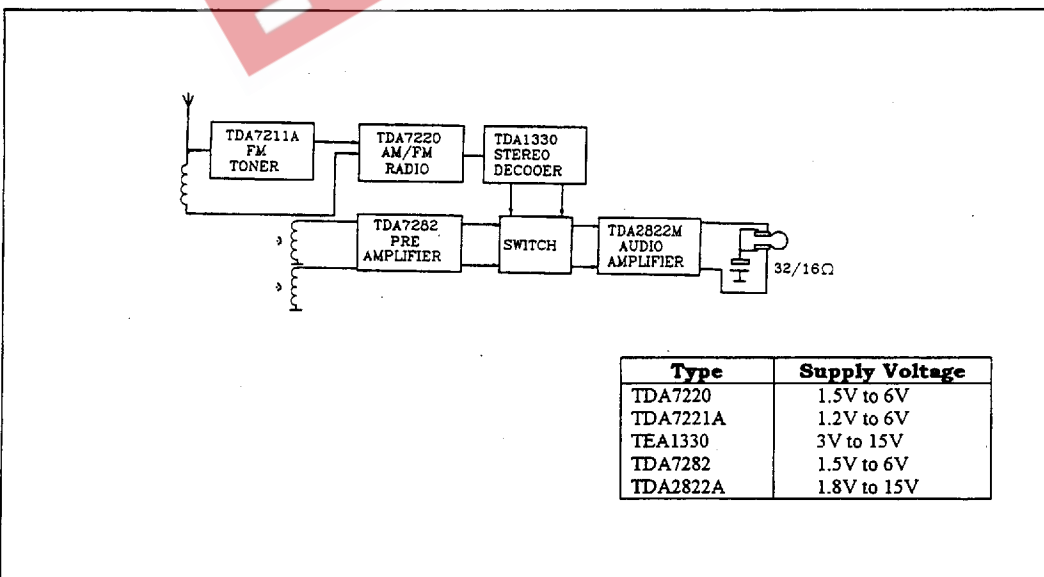

Figure 6. Portable Stereo Radio

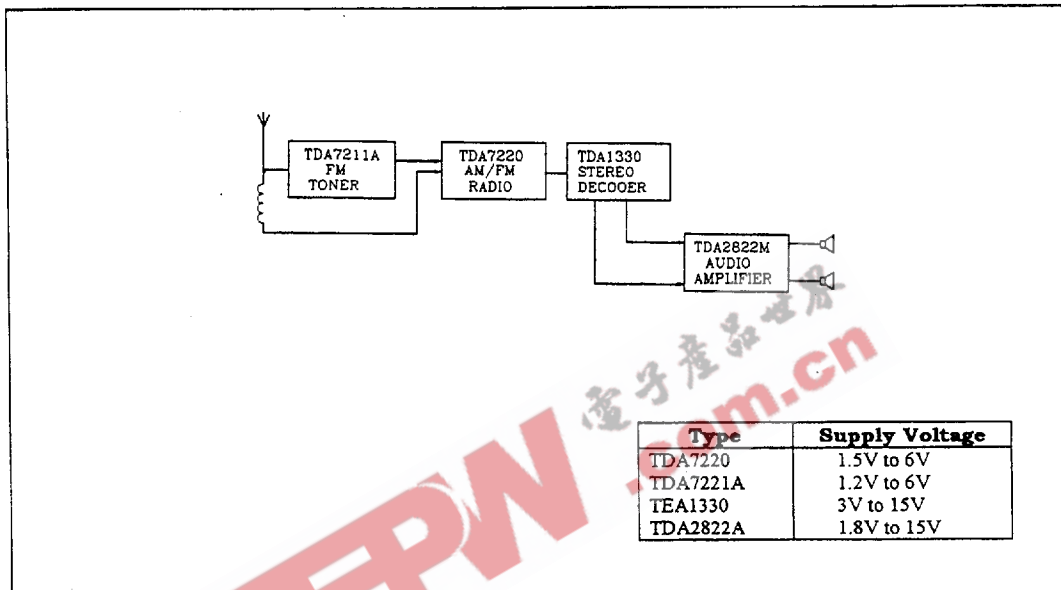

Figure 7. Low Cost Application in Portable Players (using only one 100 μ F output capacitor)

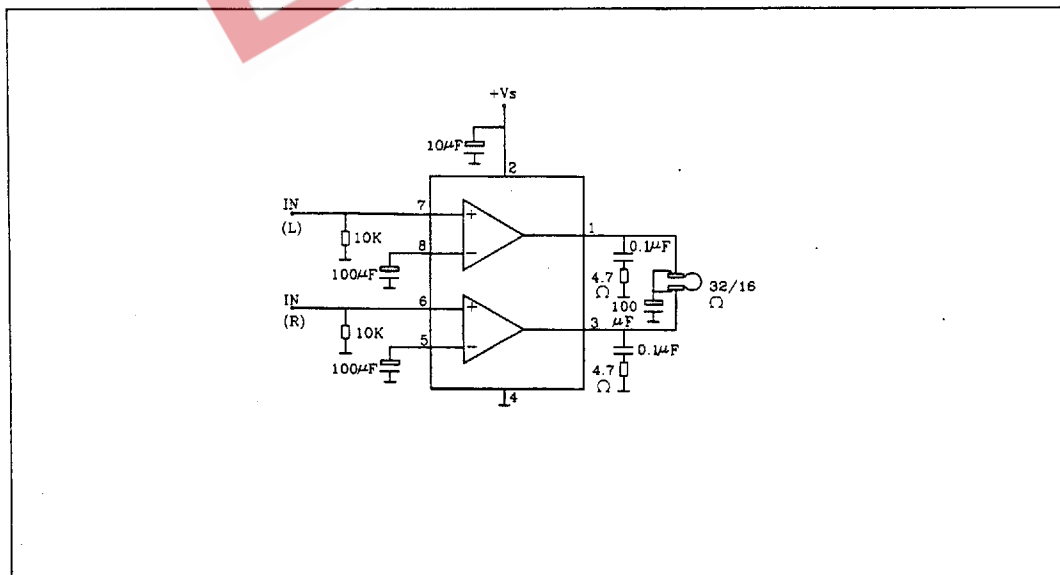

Figure 8.3V Stereo Cassette Player with Motor Speed Control

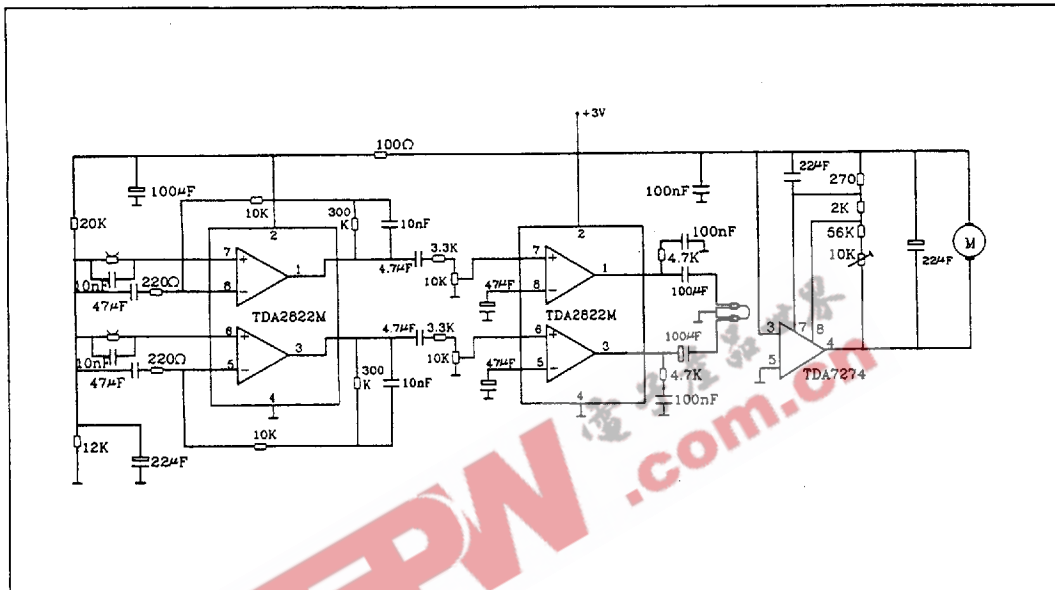

Figure 9. Quiescent Current versus Supply Voltage

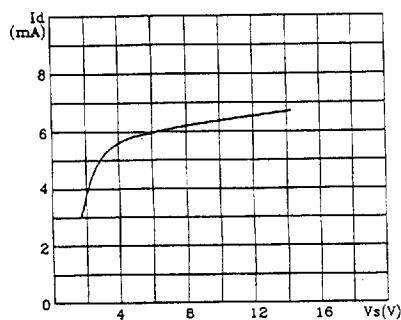

Figure 10. Supply Voltage Rejection versus Frequency

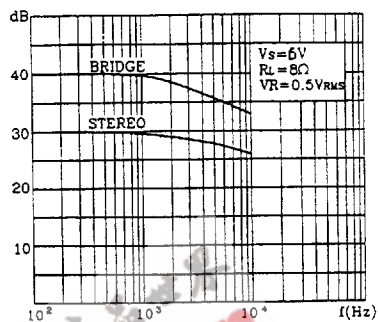

Figure 11. Output Power versus Supply Voltage (THD=10%, f=1KHz Stereo)

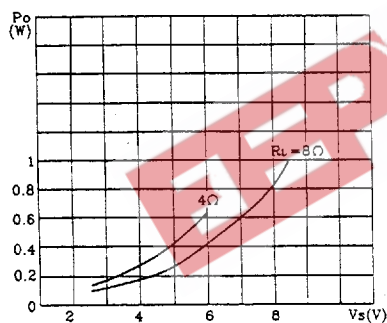

Figure 12. Distorsion versus Output Power (Stereo)

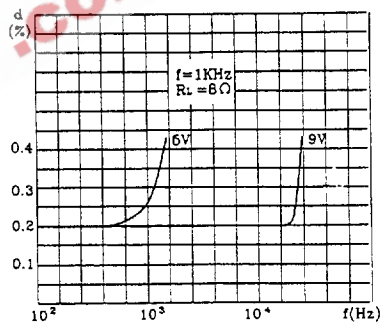

Figure 13. Distorsion versus Output Power (Stereo)

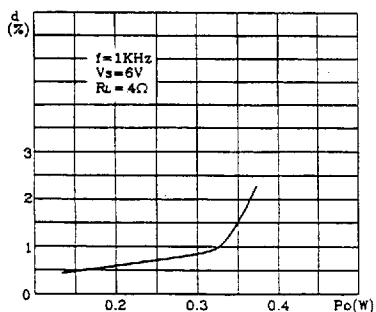

Figure 14. Output Power versus Supply Voltage (Bridge)

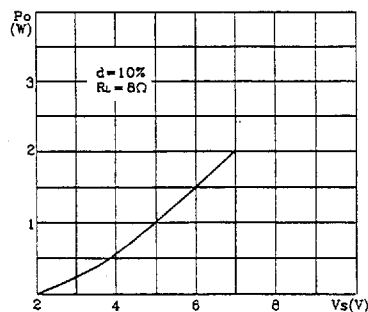

Figure 15. Distorsion versus Output Power (Bridge)

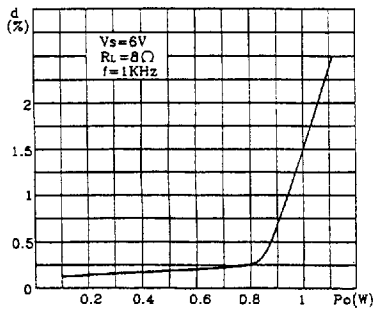

Figure 16. Total Power Dissipation versus Output Power (Bridge)

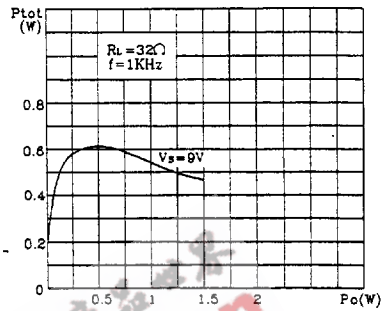

Figure 17. Total Power Dissipation versus Output Power (Bridge)

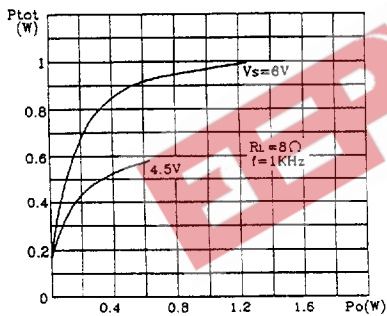

Figure 18. Total Power Dissipation versus Output Power (Bridge)

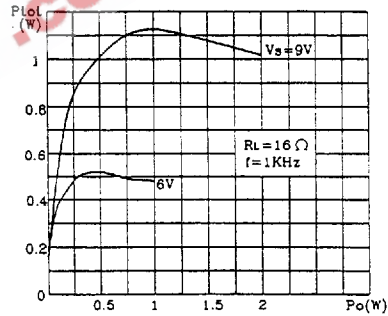

Figure 19. Total Power Dissipation versus Output Power (Bridge)

