

TDA2590

TV HORIZONTAL OSCILLATOR COMBINATION FAIRCHILD LINEAR INTEGRATED CIRCUITS

GENERAL DESCRIPTION — The TDA2590 is a monolithic integrated circuit designed as a horizontal oscillator combination for TV receivers and monitors. It is constructed using the Fairchild Planar* process.

- LINE OSCILLATOR USING THE THRESHOLD SWITCHING PRINCIPLE
- PHASE COMPARISON BETWEEN SYNC PULSE AND OSCILLATOR VOLTAGE (ϕ_1)
- PHASE COMPARISON BETWEEN LINE FLYBACK PULSE AND OSCILLATOR VOLTAGE (ϕ_2)
- SWITCH FOR CHANGING THE FILTER CHARACTERISTIC AND THE GATE CIRCUIT (WHEN USED FOR VCR)
- COINCIDENCE DETECTOR (ϕ_3)
- SYNC SEPARATOR
- NOISE SEPARATOR
- NOISE SEPARATOR
- VERTICAL SYNC SEPARATOR AND OUTPUT STAGE
- COLOR BURST KEYING AND LINE FLYBACK BLANKING PULSE GENERATOR
- PHASE SHIFTER FOR THE OUTPUT PULSE
- OUTPUT PULSE DURATION SWITCHING
- OUTPUT STAGE FOR DIRECT DRIVE OF THYRISTOR DEFLECTION CIRCUITS
- SYNC GATING PULSE GENERATOR
- LOW SUPPLY VOLTAGE PROTECTION

*Planar is a patented Fairchild process.

CONNECTION DIAGRAM 16-PIN DIP (TOP VIEW) PACKAGE OUTLINE 9B

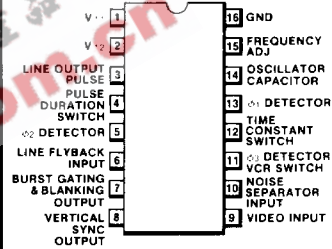

ORDER INFORMATION
TYPE PART NO.
2590 TDA2590

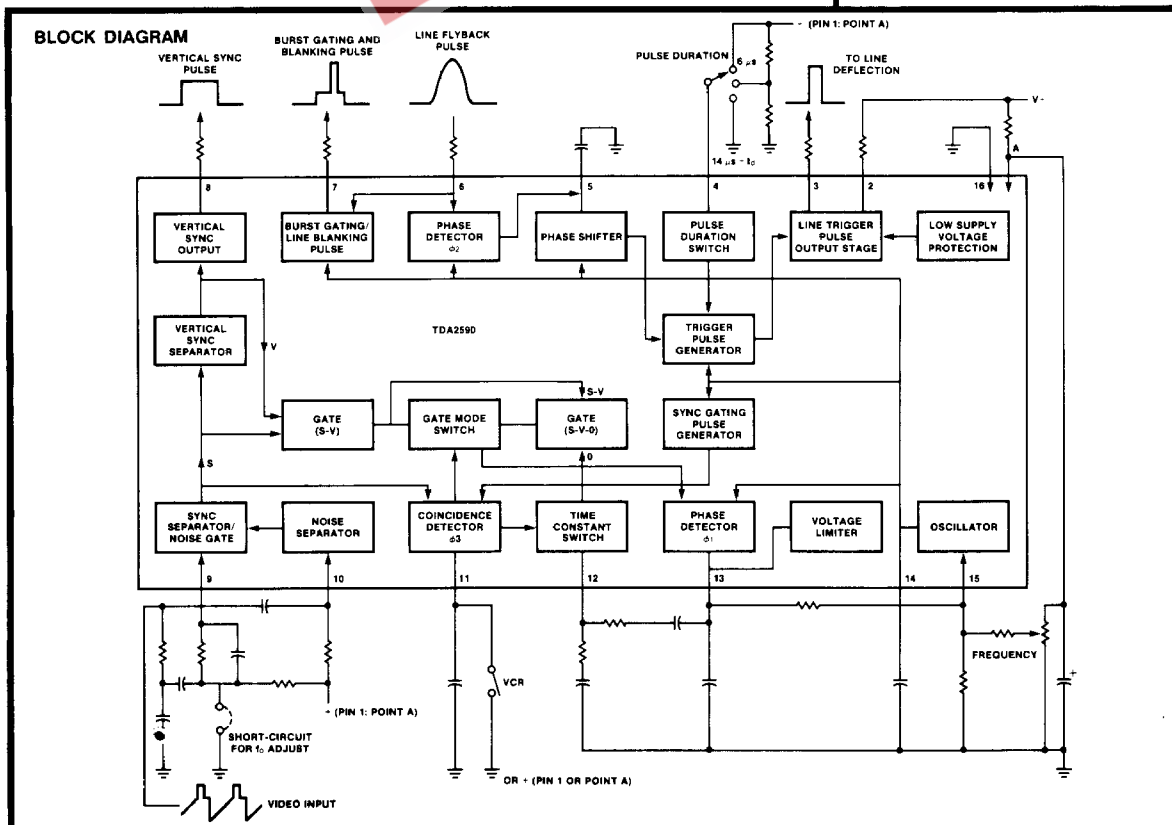

FAIRCHILD • TDA2590

ABSOLUTE MAXIMUM RATINGS

Supply Voltage at Pin 1 (When Supplied by the IC)	13.2 V
Supply Voltage at Pin 2	18 V
Power Dissipation	800 mW
Storage Temperature	-25°C to +125°C
Operating Temperature	-20°C to +60°C
Pin Temperature (Soldering, 10 s)	260°C

VOLTAGES

V ₄ , V ₁₁	0 to 13.2 V
V ₉ , V ₁₀	-6 to +6 V

CURRENTS

I ₂ (peak)	400 mA
I ₃ (peak)	-400 mA
I ₄	1 mA
I ₆	±10 mA
I ₇	-10 mA
I ₁₁	2 mA

ELECTRICAL CHARACTERISTICS: T_A = 25°C; V_I = 12 V, See test circuit unless otherwise noted.

CHARACTERISTICS	CONDITIONS	MIN	TYP	MAX	UNITS	
Supply Current	I ₁		30		mA	
SYNC SEPARATOR (PIN 9)						
Input Switching Voltage	V ₉		0.8		V	
Input Keying Current	I ₉		5	100	μA	
Input Blocking Current	I ₉	V ₉ = -5 V		1	μA	
Input Switching Current	I ₉			5	μA	
Input Voltage (pk-pk)	V ₉	Sync Positive Video Signal	1	3	7	V _{pk-pk}
NOISE SEPARATOR (PIN 10)						
Input Switching Voltage	V ₁₀		1.4		V	
Input Keying Current	I ₁₀		5	100	μA	
Input Switching Current	I ₁₀		150		μA	
Input Blocking Current	I ₁₀	V ₁₀ = -5 V		1	μA	
Input Voltage (pk-pk)	V ₁₀	Sync Positive Video Signal	1	3	7	V _{pk-pk}
Superimposed Noise Voltage (pk-pk)	V _n			7	V _{pk-pk}	
LINE FLYBACK PULSE (PIN 6)						
Input Current	I ₆	10			μA	
Input Switching Voltage	V ₆		1.4		V	
Input Limiting Voltage	V ₆		-0.7 to +1.4		V	
Input Resistance	R ₆		400		Ω	
PULSE DURATION SWITCH (PIN 4)						
Input Voltage	V ₄	t = 0 μs, V ₃ = 0 (Note 1)		5.4 to 6.5	V	
		t = 6 μs		9.4 to V ₁	V	
		t = 14 μs + t _d (Note 6)		0 to 4	V	
Input Current	I ₄	t = 0 μs, V ₃ = 0		0	μA	
		t = 6 μs	200		μA	
		t = 14 μs + t _d (Note 6)			-200	μA

FAIRCHILD • TDA2590

ELECTRICAL CHARACTERISTICS: $T_A = 25^\circ\text{C}$; $V_1 = 12\text{ V}$, See test circuit unless otherwise noted. (Cont'd)

CHARACTERISTICS	CONDITIONS	MIN	TYP	MAX	UNITS
OSCILLATOR (PIN 14 and PIN 15)					
Low Level Threshold Voltage	V_{14}		4.4		V
High Level Threshold Voltage	V_{14}		7.6		V
Discharge Current	I_{14}		± 47		mA
Free Running Frequency	f_o $C_{14} = 4.7\text{ nF}$, $R_{15} = 12\text{ k}\Omega$		15625		Hz
Spread of Frequency	$\Delta f_o/f_o$ Note 4	-5		+5	%
Frequency Control Sensitivity	$\Delta f_o/\Delta I_{15}$		31		Hz/ μA
Adjustment Range	$\Delta f_o/f_o$		± 10		%
Frequency Change With Supply Voltage	$\frac{\Delta f_o/f_o}{\Delta V/V_{nom}}$ $V_1 = 12\text{ V}$, Note 4	-0.05		+0.05	%
Frequency Change With Supply Voltage	Δf_o $V_1 = 12\text{ to }5\text{ V}$, Note 4	-10^{-4}		+10	%
Temperature Coefficient of Oscillator Frequency per $^\circ\text{C}$	Note 4	-10^{-4}		+10 ⁻⁴	
COINCIDENCE DETECTOR (ϕ_3) and SWITCHING ON VCR (PIN 11)					
Input Voltage	V_{11} Note 2		0 to 1.5		V
Input Current	I_{11} Note 2			-200	μA
Input Voltage	V_{11}		9 to V_1		V
Input Current	I_{11}		1 to 2		mA
Output Voltage	V_{11}		0.5 to 6		V
Peak Output Current	I_{11} Without Coincidence		0.1		mA
Peak Output Current	I_{11} With Coincidence		-0.5		mA
VERTICAL SYNC PULSE (PIN 8)					
Output Voltage	V_8 Positive Going	10	11		V_{pk-pk}
Output Resistance	R_8		2		$\text{k}\Omega$
Turn-ON Delay	t_{on} Delay between leading edge of input & output signal		12		μs
Turn-OFF Delay	t_{off} Delay between trailing edge of input & output signal	t_{on}			μs
BLANKING AND BURST GATING PULSE (PIN 7)					
Burst Gating Pulse Output Voltage	V_7 Positive Going	10	11		V_{pk-pk}
Output Resistance	R_7		400		Ω
Phase Relationship to Leading Edge	t Note 3 $V_7 = 7\text{ V}$		1.9 typ 1.0 to 2.8		μs
Phase Relationship to Trailing Edge	t Note 3 $V_7 = 7\text{ V}$		6.6 typ 5.8 to 7.4		μs
Blanking Pulse Output Voltage	V_7		2.5 to 3.5		V
LINE DRIVE PULSE (PIN 3)					
Output Voltage	V_3 Positive Going		10.5		V_{pk-pk}
Output Current (Average Value)	I_3		-100		mA
Output Resistance	R_3 For leading edge of Line Pulse		2.5		Ω
Output Resistance	R_3 For trailing edge of Line Pulse		20		Ω
Output Pulse Duration	t_p $V_4 > 9.4\text{ V}$		6 typ 4.5-7.5		μs
Output Pulse Duration	t_p $V_4 < 4\text{ V}$, Note 6		14 + t_d		μs
Supply Voltage for Switching off the Output Pulse	V_1		4		V

FAIRCHILD • TDA2590

ELECTRICAL CHARACTERISTICS: $T_A = 25^\circ\text{C}$; $V_1 = 12\text{ V}$. See test circuit unless otherwise noted. (Cont'd)

CHARACTERISTICS	CONDITIONS	MIN	TYP	MAX	UNITS
PHASE COMPARISON (ϕ_1) (PIN 13)					
Control Voltage Range	V_{13}		3.8 to 8.2		V
Peak Control Current	I_{13}		± 2.1 typ ± 1.9 -2.3		mA
Output Blocking Current	I_{13}			1	μA
Output Resistance	R_{13}		High		ohmic
Output Resistance	R_{13}		Low		ohmic
Control Sensitivity			2		$\text{kHz}/\mu\text{s}$
Capture & Holding Range	Δf		± 780		Hz
Spread of Capture & Holding Range	$\Delta(\Delta f)$		± 10		%
PHASE COMPARISON (ϕ_2) (PIN 5)					
Control Voltage Range	V_5		5.4 to 7.6		V
Peak Control Current	I_5		± 1		mA
Input Current at Blocked Phase Detector	I_5			5	μA
Output Resistance	R_5		High		ohmic
Output Resistance	R_5		8		$\text{k}\Omega$
Allowable Delay between Leading Edge of Output Pulse and Leading Edge of Flyback Pulse ($t_p = 12\ \mu\text{s}$)	t_d		0-15		μs
Static Control Error	$\Delta t/\Delta t_d$			0.2	%
OVERALL PHASE RELATION					
Phase Relation Between Middle of Sync Pulse and the Middle of the Flyback Pulse	t		2.6		μs
Tolerance of Phase Relationship	Δt	-0.7		+0.7	μs
TIME CONSTANT SWITCH (PIN 12)					
Output Voltage	V_{12}		6		V
Output Current	I_{12}	-1		+1	mA
Output Resistance	R_{12}		100		Ω
Output Resistance	R_{12}		60		$\text{k}\Omega$
INTERNAL GATING PULSE					
Pulse Duration	t_p		7.5		μs

NOTES:

- Can also be left unconnected.
- When supplied by the IC.
- Phase relationship between the middle of the sync pulse at the input and leading or trailing edge of the burst gating pulse.
- Excluding the affect of variations in external components tolerances.
- The adjustment of the overall phase relation and consequently the leading edge of the output pulse occurs automatically by phase control ϕ_2 . If additional adjustment is used, the following values apply:
ADJUSTMENT SENSITIVITY
caused by: adjustment voltage $\Delta V_5/\Delta t$ typ 0.1 V/ μs
adjustment current $\Delta I_5/\Delta t$ typ 30 $\mu\text{A}/\mu\text{s}$
- t_d = switch-OFF delay of the line output stage.

FAIRCHILD • TDA2590

EQUIVALENT CIRCUIT

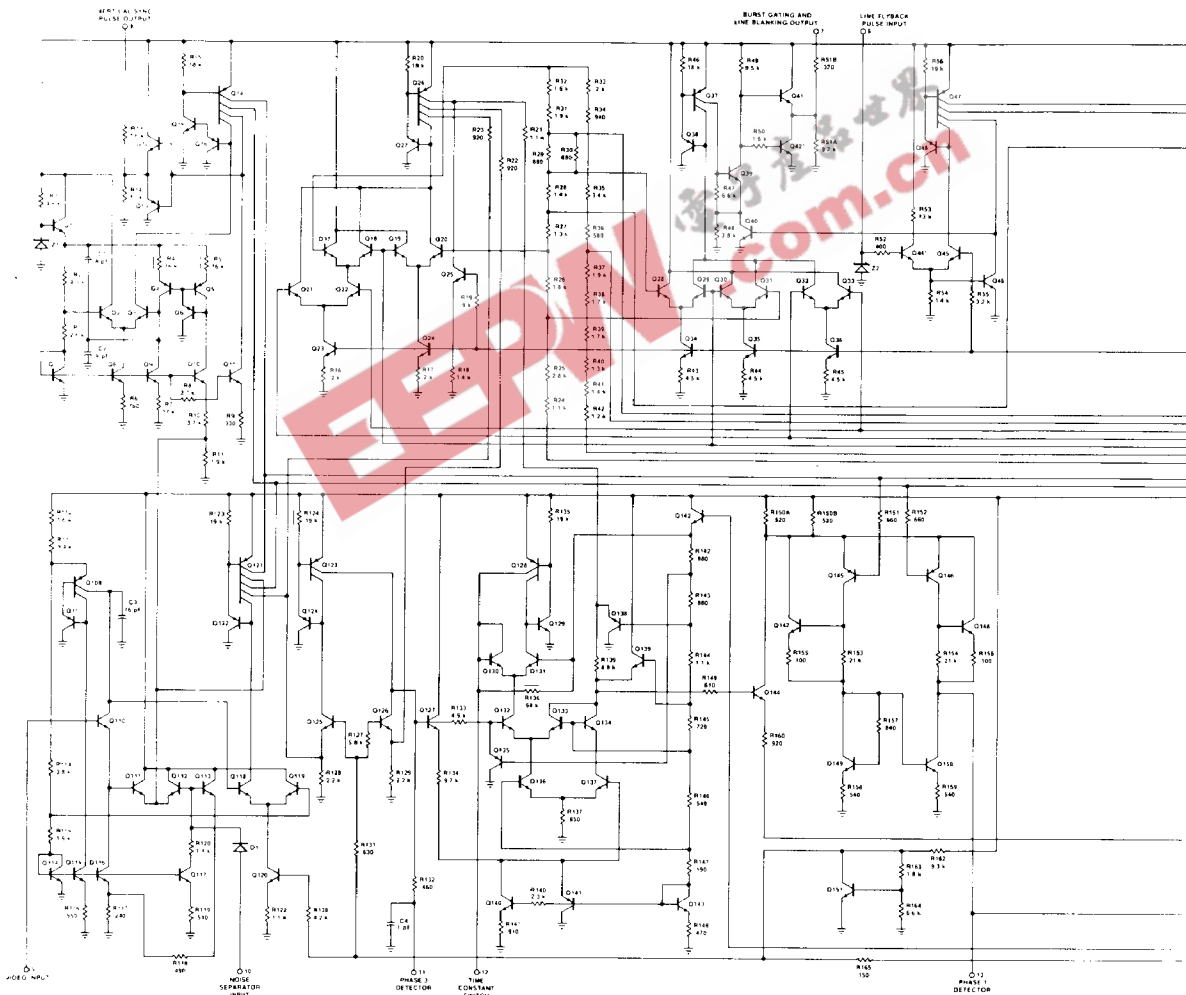

FAIRCHILD • TDA2590

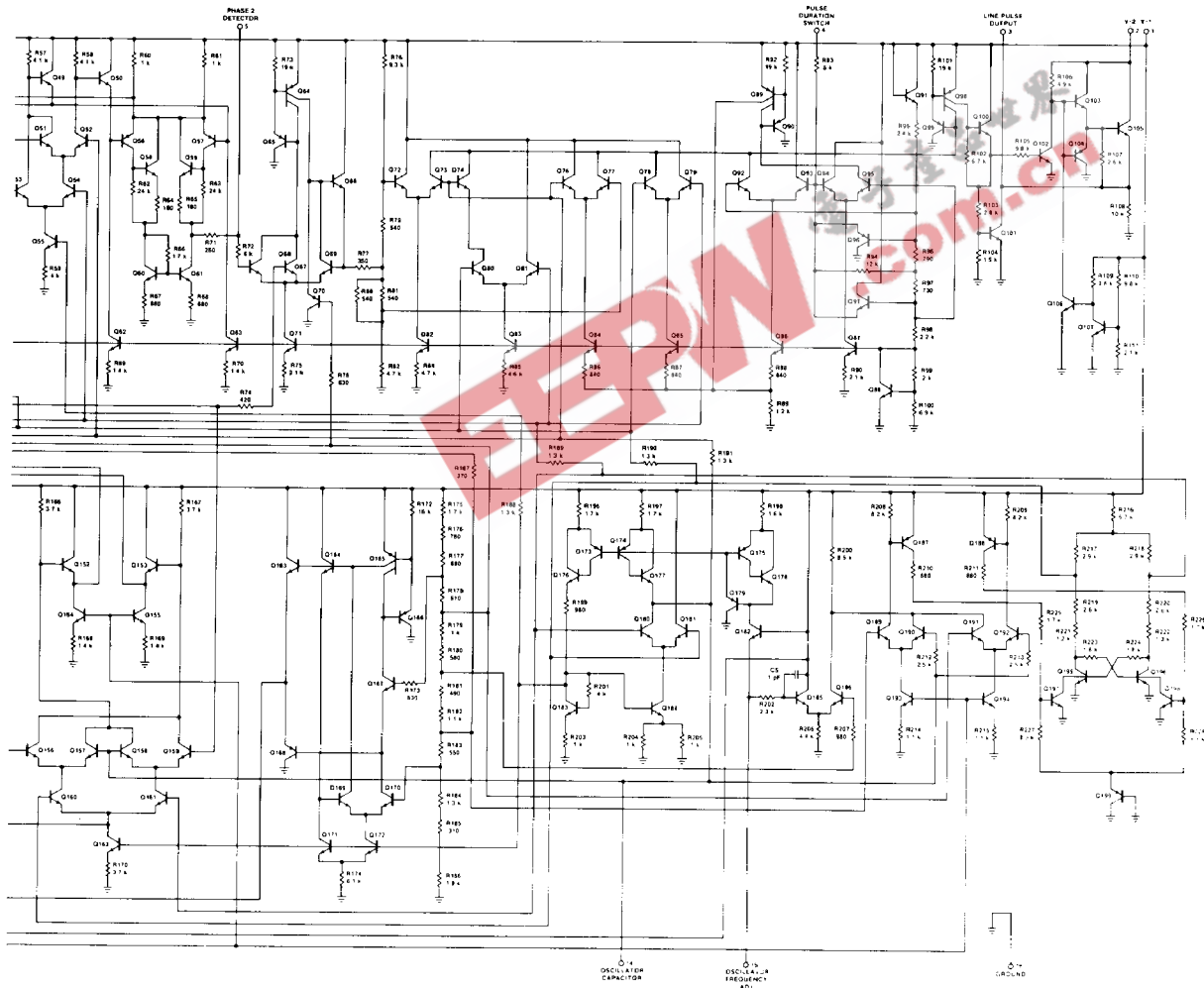

FAIRCHILD • TDA2590

TEST AND APPLICATIONS CIRCUIT

