



4		AGC time constant
5		Intercarrier output 5.74 MHz
6		Standard switch
7		AF output 1
8-9		Phase tank circuit 5.74 MHz
10		VC0 tank circuit

14		AF output 2
15		Intercarrier output 5.5 MHz
16		Supply voltage
17		Intercarrier input 5.5 MHz
18-19		Sound-IF-carrier input
20		n.c.

## Circuit Description

The integrated circuit allows the high quality processing of sound carrier for different TV standards. The circuit requires separate vision and audio carrier inputs. It delivers the output audio signal for mono, two channels or stereo applications.

Audio carrier signal (simple or double carrier, FM and AM) is applied via three stage AGC controlled broad band amplifier which delivers regulated output signal for two mixing stages. One mixer works for AM-demodulation and AGC-function whereas the second mixer produces the sound intercarrier IF-frequencies (5.5/5.74 MHz).

Vision carrier signal for the intercarrier generation is delivered from the demodulator tank of the video IF circuit (TDA 4439, TDA 4453). It is then matched via a limiter stage to the FM intercarrier mixer. FM-sound-IF-carrier reaches the quadrature demodulator via the selection circuit and the following limiter amplifier. The final audio signal is supplied to the low ohmic output (Pin 7,14) with low pass filter character.

There is a switchable converter for different audio standards (4.5, 6.00 and 6.5 MHz), which mixes the sound 1P-signal properly e.g. at 5.5 MHz. The VC0 (Pin 10) must be controlled across the sound output (Pin 7) which includes AFC-function.

Sound signal at the AM-modulation is introduced via standard switch in the first sound channel, whereas the intercarrier, converter section and both FM demodulators are switched off. In case of sound IF converter operation, the second sound channel and the AM-section are switched off. The standard mode is controlled by a tristate signal on Pin 6.

## Absolute Maximum Ratings

Reference point Pin 11, unless otherwise specified

Parameters	Symbol	Value	Unit
Supply voltage	Pin 16 $V_S$	10 to 13.5	V
Supply current	Pin 16 $I_S$	80	mA
External voltage	Pin 6 $V_{ext}$	$V_S$	V
	Pin 1, 2, 3, 4, 5, 7, 8, 9, 12, 13, 14, 15, 17, 18, 19 $V_{ext}$	6	V
Power dissipation (in soldered position)	$P_{tot}$	1	W
Junction temperature	$T_j$	125	°C
Ambient temperature range	$T_{amb}$	- 25 to + 70	°C
Storage temperature range	$T_{stg}$	- 25 to + 125	°C

## Electrical Characteristics

$V_5 = 12\text{ V}$ ,  $T_{\text{amb}} = 25\text{ }^\circ\text{C}$ , reference point pin 11,  $f_{\text{PC}} = 38.9\text{ MHz}$ ,  $f_{\text{SC1}} = 33.4\text{ MHz}$ ,  $f_{\text{SC2}} = 33.1578\text{ MHz}$ ,  $\text{SC1/SC2} = -7\text{ dB}$ , unless otherwise specified

Parameters	Test Conditions / Pin	Symbol	Min	Type	Max	Unit
Supply voltage range	Pin 16	$V_S$	10		13.5	V
Supply current	FM-operation, Pin 16	$I_S$		65		mA
	AM-operation, Pin 16	$I_S$		40		mA
Output DC voltage	Pin 7,14	$V_0$		3.5		V
Standard switching voltage	Standard B/G, Pin 6	V	1.7	2.2	2.7	V
	Standard L, Pin 6	V	0		1.5	V
	converter operation Pin 6	V	3.5		$V_S$	V
Standard switching current	$V_6 \leq 5\text{ V}$ Pin 6	I			20	$\mu\text{A}$
Picture carrier input voltage	Pin 1,2	v	5	10	20	mV
Min. sound carrier input voltage SC1	5.5 MHz-output signal $-3\text{ dB}$ Pin 18,19	v		50		$\mu\text{V}$
Max. sound carrier input voltage SC1	Pin 18,19	v		100		mV
AGC range				65		dB
Audio output voltage	FM-deviation = 30 kHz m = 80 % Pin 7,14	v		500		$\text{mV}_{\text{eff}}$
Audio voltage difference between both outputs	Pin 7,14	v			$\pm 1$	dB
Harmonic distortion AM-operation	$f_{\text{mod}} = 1\text{ kHz}$ , Pin 7,14 FM-deviation = 30 kHz	d		0.5		%
Harmonic distortion AM-operation	$f_{\text{mod}} = 1\text{ kHz}$ , Pin 7 m = 80 %, $v_{18-19} = 10\text{ mV}$	d		1.5	3.0	%
Min. output load	Pin 7,14	R		3		$\text{k}\Omega$
Signal to noise ratio (Standard B/G) according to CCIR 468-2 specifications, SC1: $v_{18-19} = 10\text{ mV}$ , PC: $v_{1-2} = 10\text{ mV}$ , prelimited demodulator picture carrier signal from TDA 4453 reference signal: $f_{\text{mod}} = 1\text{ kHz}$ , FM deviation = 30 kHz						
Black burst 1. channel/2. channel <sup>1)</sup>	Pin 7/14	(S=N)/N		62/60		dB
Grid test signal 1. channel/2. channel <sup>1)</sup>	Pin 7/14	(S=N)/N		50/48		dB
<b>Converter</b>						
DC voltage	$V_6 \geq 3.5\text{ V}$ Pin 10	$V_{10}$		2.7		V
Tuning range	Pin 10	f	9		13	MHz
Input resistance	Pin 10	R		100		$\text{k}\Omega$
Input capacity	Pin 10	C		12		pF

Black burst 1. channel/2. channel <sup>1)</sup>		Pin 7/14	(S=N)/N		62/60		dB
Grid test signal 1. channel/2. channel <sup>1)</sup>		Pin 7/14	(S=N)/N		50/48		dB
<b>Converter</b>							
DC voltage	$V_6 \geq 3.5 \text{ V}$	Pin 10	$V_{10}$		2.7		V
Tuning range		Pin 10	f	9		13	MHz
Input resistance		Pin 10	R		100		k $\Omega$
Input capacity		Pin 10	C		12		pF

<sup>1)</sup> Standard B/G IF-modulated FBAS-signal

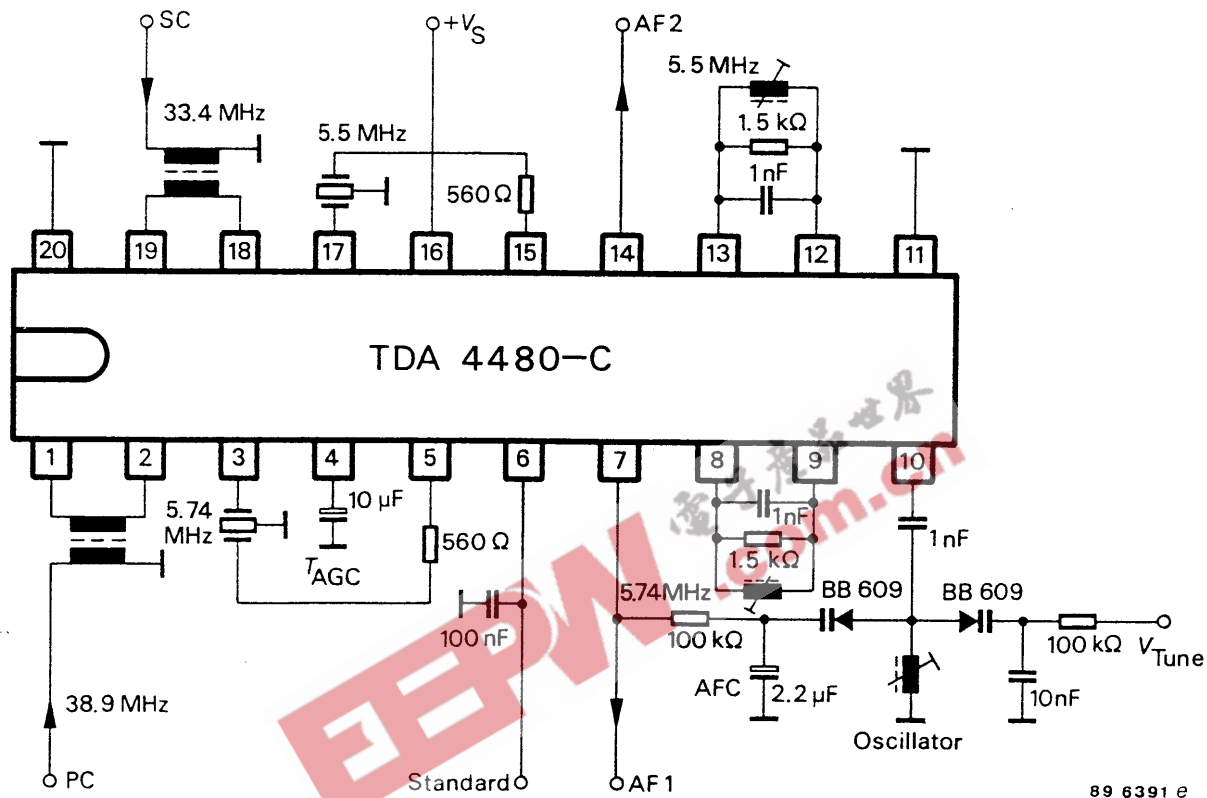

89 6391 e

Figure 2: Test circuit

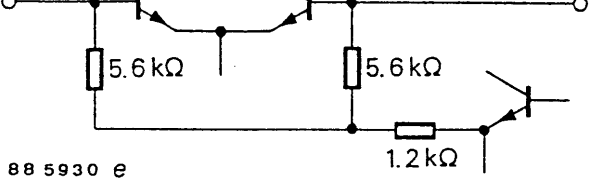

Pin 1,2  
IF-input  
vision carrier

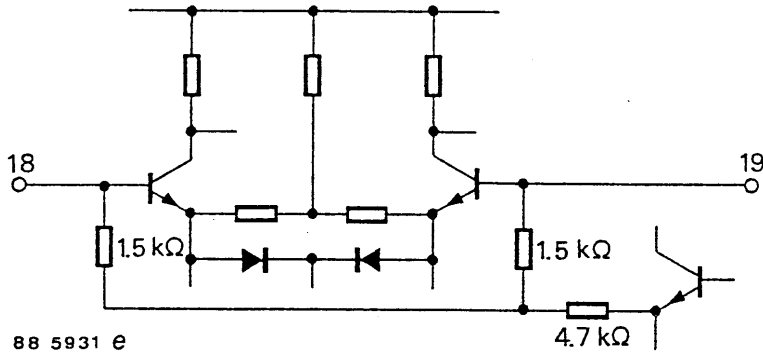

Pin 18,19  
IF-input  
sound carrier

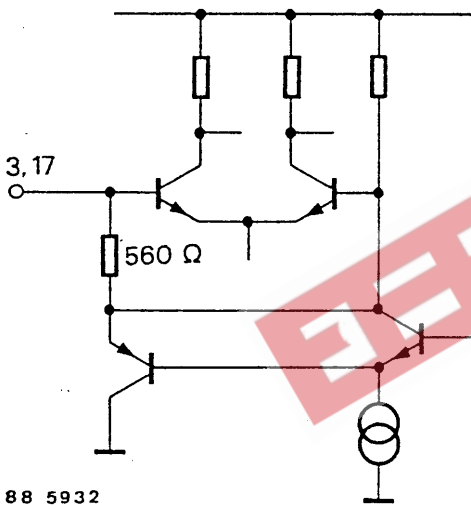

Pin 3 (17)  
Intercarrier input  
Pin 3: 5.74 MHz  
Pin 17: 5.5 MHz

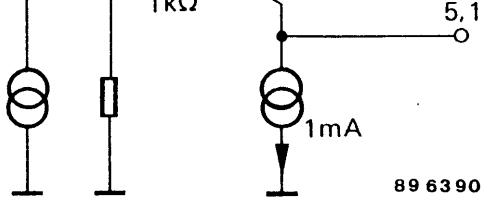

Pin 5 (15)  
 Intercarrier output  
 Pin 5: 5.74 MHz  
 Pin 15: 5.5 MHz

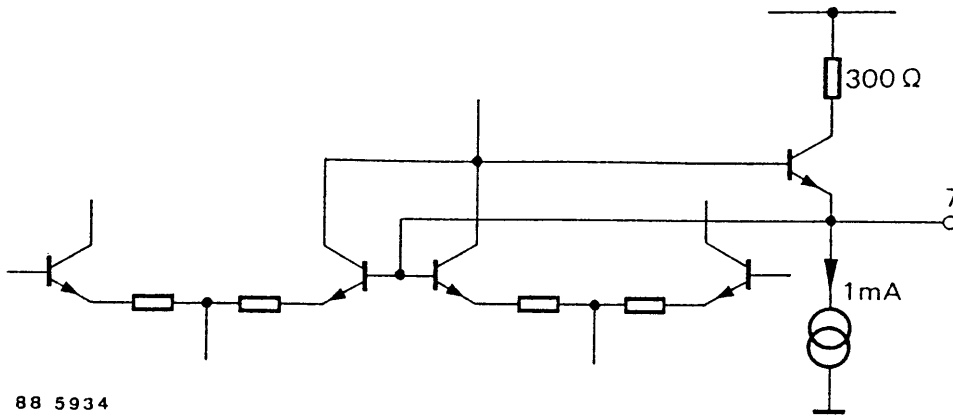

Pin 7  
 AP-output AM/PM  
 (channel 1, 5.5 MHz)

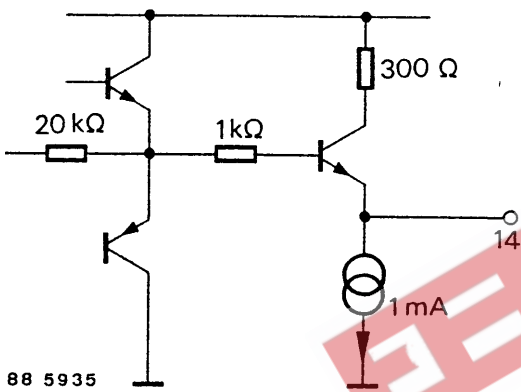

Pin 14  
 AF-output FM  
 (channel 2, 5.74 MHz)

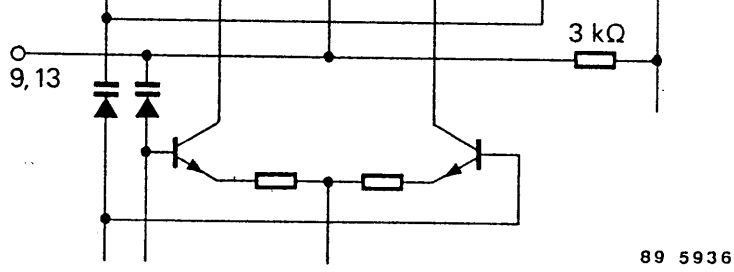

Pin 8,9 (12,13)

Phase tank circuit  
 Pin 8, 9 : 5.74 MHz  
 Pin 12,13 : 5.5 MHz

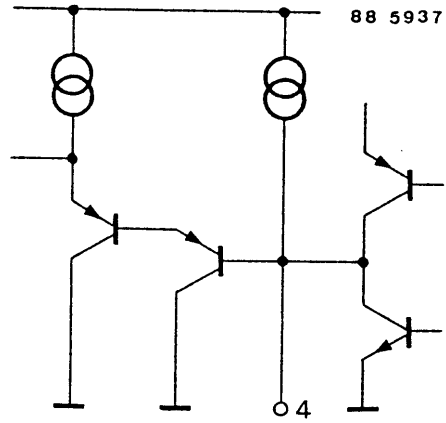

Pin 4

AGC time constant

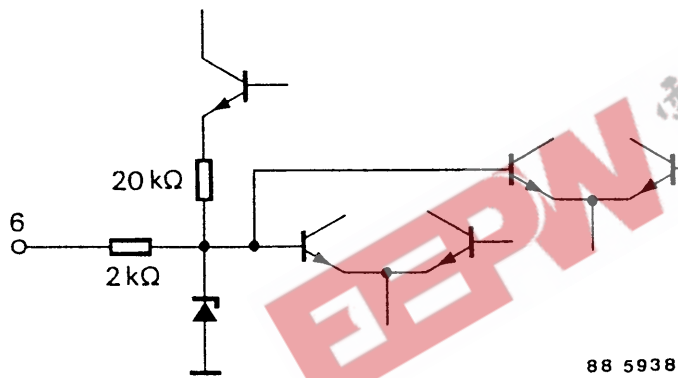

Pin 6

Standard switch

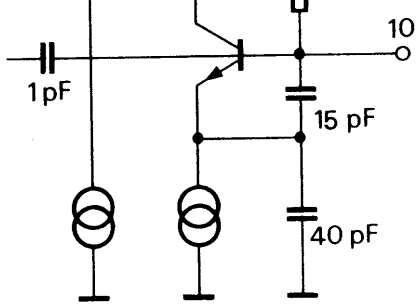

Pin 10  
VC0 tank circuit

**Dimensions in mm**

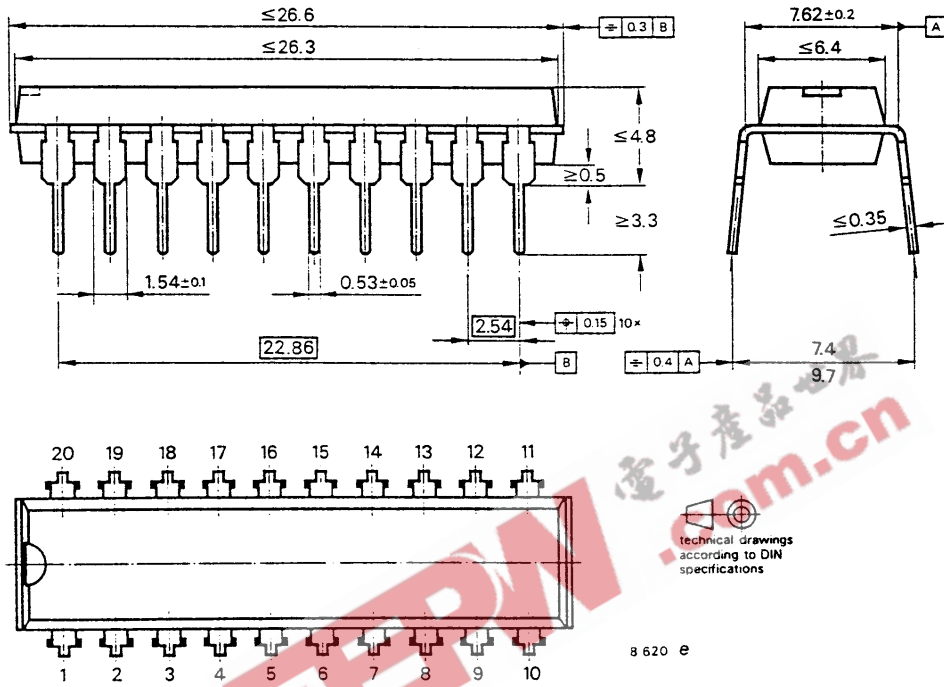

Case:  
DIP 20



2. Regularly and continuously improve the performance of our products, processes, distribution and operating systems with respect to their impact on the health and safety of our employees and the public, as well as their impact on the environment.

Of particular concern is the control or elimination of releases into the atmosphere of those substances which are known as ozone depleting substances (ODS).

The Montreal Protocol (1987) and its London Amendments (1990) will soon severely restrict the use of ODSs and forbid their use within the next ten years. Various national and international initiatives are pressing for an earlier ban on these substances.

**TEMIC TELEFUNKEN microelectronic GmbH** semiconductor division has been able to use its policy of continuous improvements to eliminate the use of any ODSs listed in the following documents.

1. Annex A, B and list of transitional substances of the Montreal Protocol and the London Amendments respectively
2. Class I and II ozone depleting substances in the Clean Air Act Amendments of 1990 by the Environmental Protection Agency (EPA) in the USA and
3. Council Decision 88/540/EEC and 91/690/EEC Annex A, B and C (transitional substances) respectively.

**TEMIC** can certify that our semiconductors are not manufactured with and do not contain ozone depleting substances.

**We reserve the right to make changes to improve technical design without further notice.**

Parameters can vary in different applications. All operating parameters must be validated for each customer application by the customer. Should the buyer use TEMIC products for any unintended or unauthorized application, the buyer shall indemnify TEMIC against all claims, costs, damages, and expenses, arising out of, directly or indirectly, any claim of personal damage, injury or death associated with such unintended or unauthorized use.

TEMIC TELEFUNKEN microelectronic GmbH, P.O.B. 3535, D-74025 Heilbronn, Germany  
Telephone: 49 (0)7131 67 2831, Fax Number: 49 (0)7131 67 2423

Preliminary Information