

500-mA PEAK STEP-UP, STEP-DOWN, INVERTING SWITCHING VOLTAGE REGULATOR

SLVS009F – JUNE 1976 – REVISED FEBRUARY 2005

- High Efficiency . . . 60% or Greater
- Peak Switch Current . . . 500 mA
- Input Current Limit Protection
- TTL-Compatible Inhibit
- Adjustable Output Voltage
- Input Regulation . . . 0.2% Typ
- Output Regulation . . . 0.4% Typ
- Soft Start-Up Capability
- Can be Used in Buck, Boost, and Inverting Configurations

D, N, OR PW PACKAGE  
(TOP VIEW)

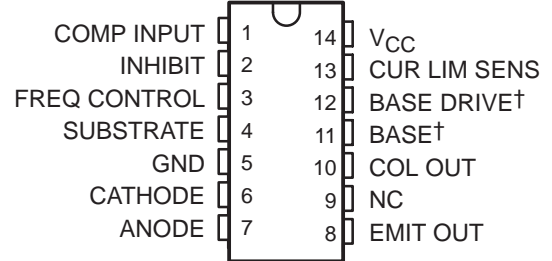

NC – No internal connection  
† BASE (11) and BASE DRIVE (12) are used for device testing only. They normally are not used in circuit applications of the device.

description/ordering information

The TL497A incorporates all the active functions required in the construction of switching voltage regulators. It also can be used as the control element to drive external components for high-power-output applications. The TL497A was designed for ease of use in step-up, step-down, or voltage-inversion applications requiring high efficiency.

The TL497A is a fixed-on-time variable-frequency switching-voltage-regulator control circuit. The switch-on time is programmed by a single external capacitor connected between FREQ CONTROL and GND. This capacitor,  $C_T$ , is charged by an internal constant-current generator to a predetermined threshold. The charging current and the threshold vary proportionally with  $V_{CC}$ . Thus, the switch-on time remains constant over the specified range of input voltage (4.5 V to 12 V). Typical on times for various values of  $C_T$  are as follows:

TIMING CAPACITOR, $C_T$ (pF)	200	250	350	400	500	750	1000	1500	2000
ON TIME ( $\mu$ s)	19	22	26	32	44	56	80	120	180

The output voltage is controlled by an external resistor ladder network ( $R_1$  and  $R_2$  in Figures 1, 2, and 3) that provides a feedback voltage to the comparator input. This feedback voltage is compared to the reference voltage of 1.2 V (relative to SUBSTRATE) by the high-gain comparator. When the output voltage decays below the value required to maintain 1.2 V at the comparator input, the comparator enables the oscillator circuit, which charges and discharges  $C_T$  as described above. The internal pass transistor is driven on during the charging of  $C_T$ . The internal transistor can be used directly for switching currents up to 500 mA. Its collector and emitter are uncommitted, and it is current driven to allow operation from the positive supply voltage or ground. An internal Schottky diode matched to the current characteristics of the internal transistor also is available for blocking or commutating purposes. The TL497A also has on-chip current-limit circuitry that senses the peak currents in the switching regulator and protects the inductor against saturation and the pass transistor against overstress. The current limit is adjustable and is programmed by a single sense resistor,  $R_{CL}$ , connected between  $V_{CC}$  and CUR LIM SENS. The current-limit circuitry is activated when 0.7 V is developed across  $R_{CL}$ . External gating is provided by the INHIBIT input. When the INHIBIT input is high, the output is turned off.

Simplicity of design is a primary feature of the TL497A. With only six external components (three resistors, two capacitors, and one inductor), the TL497A operates in numerous voltage-conversion applications (step-up, step-down, invert) with as much as 85% of the source power delivered to the load. The TL497A replaces the TL497 in all applications.

The TL497AC is characterized for operation from 0°C to 70°C. The TL497AI is characterized for operation from -40°C to 85°C.



Please be aware that an important notice concerning availability, standard warranty, and use in critical applications of Texas Instruments semiconductor products and disclaimers thereto appears at the end of this data sheet.

PRODUCTION DATA information is current as of publication date. Products conform to specifications per the terms of Texas Instruments standard warranty. Production processing does not necessarily include testing of all parameters.



Copyright © 2005, Texas Instruments Incorporated

# TL497A 500-mA PEAK STEP-UP, STEP-DOWN, INVERTING SWITCHING VOLTAGE REGULATOR

SLVS009F – JUNE 1976 – REVISED FEBRUARY 2005

## AVAILABLE OPTIONS

T <sub>A</sub>	PACKAGED DEVICES			CHIP FORM (Y)
	SMALL-OUTLINE (D)	PLASTIC DIP (N)	SHRINK SMALL-OUTLINE (PW)	
0°C to 70°C	TL497ACD	TL497ACN	TL497ACPW	TL497AY
-40°C to 85°C	TL497AID	TL497AIN	—	—

The D and PW packages are only taped and reeled. Add the suffix R to the device type (e.g., TL497ACPWR). Chip forms are tested at 25°C.

## functional block diagram

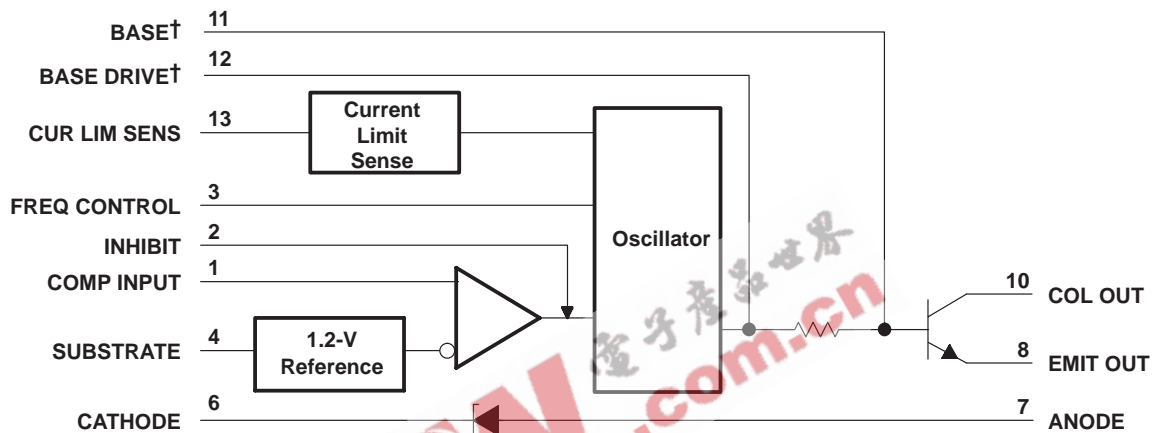

† BASE and BASE DRIVE are used for device testing only. They normally are not used in circuit applications of the device.

500-mA PEAK STEP-UP, STEP-DOWN, INVERTING SWITCHING VOLTAGE REGULATOR

SLVS009F – JUNE 1976 – REVISED FEBRUARY 2005

absolute maximum ratings over operating free-air temperature range (unless otherwise noted)†

Supply voltage, $V_{CC}$ (see Note 1)	15 V
Output voltage, $V_O$	35 V
Input voltage, $V_I$ (COMP INPUT)	5 V
Input voltage, $V_I$ (INHIBIT)	5 V
Diode reverse voltage	35 V
Power switch current	750 mA
Diode forward current	750 mA
Package thermal impedance, $\theta_{JA}$ (see Notes 2 and 3): D package	86°C/W
N package	101°C/W
PW package	113°C/W
Lead temperature 1,6 mm (1/16 inch) from case for 60 seconds	260°C
Storage temperature range, $T_{stg}$	-65°C to 150°C

†Stresses beyond those listed under “absolute maximum ratings” may cause permanent damage to the device. These are stress ratings only, and functional operation of the device at these or any other conditions beyond those indicated under “recommended operating conditions” is not implied. Exposure to absolute-maximum-rated conditions for extended periods may affect device reliability.

- NOTES:
1. All voltage values, except diode voltages, are with respect to network ground terminal.
  2. Maximum power dissipation is a function of  $T_J(max)$ ,  $\theta_{JA}$ , and  $T_A$ . The maximum allowable power dissipation at any allowable ambient temperature is  $P_D = (T_J(max) - T_A)/\theta_{JA}$ . Operating at the absolute maximum  $T_J$  of 150°C can impact reliability.
  3. The package thermal impedance is calculated in accordance with JESD 51, except for through-hole packages, which use a trace length of zero.

recommended operating conditions

		MIN	MAX	UNIT	
Supply voltage, $V_{CC}$		4.5	12	V	
High-level input voltage, $V_{IH}$	INHIBIT pin	2.5		V	
Low-level input voltage, $V_{IL}$	INHIBIT pin		0.8	V	
Output voltage	Step-up configuration (see Figure 1)	$V_I + 2$	30	V	
	Step-down configuration (see Figure 2)	$V_{ref}$	$V_I - 1$		
	Inverting regulator (see Figure 3)	$-V_{ref}$	-25		
Power switch current			500	mA	
Diode forward current			500	mA	
Operating free-air temperature range, $T_A$		TL497AC	0	70	°C
		TL497AI	-40	85	

# TL497A

## 500-mA PEAK STEP-UP, STEP-DOWN, INVERTING SWITCHING VOLTAGE REGULATOR

SLVS009F – JUNE 1976 – REVISED FEBRUARY 2005

electrical characteristics over recommended operating conditions,  $V_{CC} = 6\text{ V}$  (unless otherwise noted)

PARAMETER	TEST CONDITIONS	$T_A$ †	TL497AC			TL497AI			UNIT
			MIN	TYP‡	MAX	MIN	TYP‡	MAX	
High-level input current, INHIBIT	$V_{I(I)} = 5\text{ V}$	Full range	0.8	1.5		0.8	1.5	mA	
Low-level input current, INHIBIT	$V_{I(I)} = 0\text{ V}$	Full range	5	10		5	20	$\mu\text{A}$	
Comparator reference voltage	$V_I = 4.5\text{ V to }6\text{ V}$	Full range	1.08	1.2	1.32	1.14	1.2	1.26	V
Comparator input bias current	$V_I = 6\text{ V}$	Full range	40	100		40	100	$\mu\text{A}$	
Switch on-state voltage	$V_I = 4.5\text{ V}$	$I_O = 100\text{ mA}$	25°C	0.13	0.2		0.13	0.2	V
		$I_O = 500\text{ mA}$	Full range		0.85			1	
Switch off-state current	$V_I = 4.5\text{ V}, V_O = 30\text{ V}$	25°C		10	50		10	50	$\mu\text{A}$
		Full range			200			500	
Sense voltage, CUR LIM SENS	$V_I = 6\text{ V}$	25°C	0.45		1	0.45		1	V
Diode forward voltage	$I_O = 10\text{ mA}$	Full range		0.75	0.85		0.75	0.95	V
		Full range		0.9	1		0.9	1.1	
		Full range		1.33	1.55		1.33	1.75	
Diode reverse voltage	$I_O = 500\text{ }\mu\text{A}$	Full range				30			V
	$I_O = 200\text{ }\mu\text{A}$	Full range	30						
On-state supply current		25°C		11	14		11	14	mA
		Full range			15			16	
Off-state supply current		25°C		6	9		6	9	mA
		Full range			10			11	

† Full range is 0°C to 70°C for the TL497AC and –40°C to 85°C for the TL497AI.

‡ All typical values are at  $T_A = 25^\circ\text{C}$ .

electrical characteristics over recommended operating conditions,  $V_{CC} = 6\text{ V}$ ,  $T_A = 25^\circ\text{C}$  (unless otherwise noted)

PARAMETER	TEST CONDITIONS	TL497AY			UNIT
		MIN	TYP	MAX	
High-level input current, INHIBIT	$V_{I(I)} = 5\text{ V}$		0.8		mA
Low-level input current, INHIBIT	$V_{I(I)} = 0\text{ V}$		5		$\mu\text{A}$
Comparator reference voltage	$V_I = 4.5\text{ V to }6\text{ V}$		1.2		V
Comparator input bias current	$V_I = 6\text{ V}$		40		$\mu\text{A}$
Switch on-state voltage	$V_I = 4.5\text{ V}, I_O = 100\text{ mA}$		0.13		V
Switch off-state current	$V_I = 4.5\text{ V}, V_O = 30\text{ V}$		10		$\mu\text{A}$
Diode forward voltage	$I_O = 10\text{ mA}$		0.75		V
	$I_O = 100\text{ mA}$		0.9		
	$I_O = 500\text{ mA}$		1.33		
On-state supply current			11		mA
Off-state supply current			6		mA

APPLICATION INFORMATION

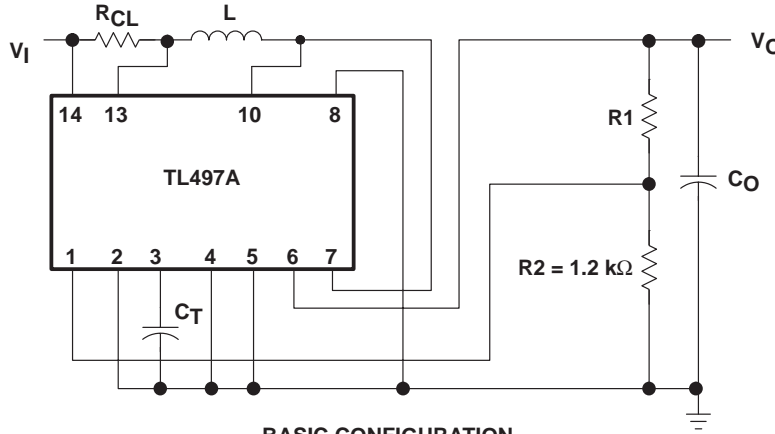

**BASIC CONFIGURATION**  
(Peak Switching Current =  $I_{(PK)} < 500 \text{ mA}$ )

DESIGN EQUATIONS

- $I_{(PK)} = 2 I_{O \text{ max}} \left[ \frac{V_O}{V_I} \right]$

- $L (\mu\text{H}) = \frac{V_I}{I_{(PK)}} t_{on} (\mu\text{s})$

Choose L (50 to 500  $\mu\text{H}$ ), calculate  $t_{on}$  (25 to 150  $\mu\text{s}$ )

- $C_T (\text{pF}) \approx 12 t_{on} (\mu\text{s})$

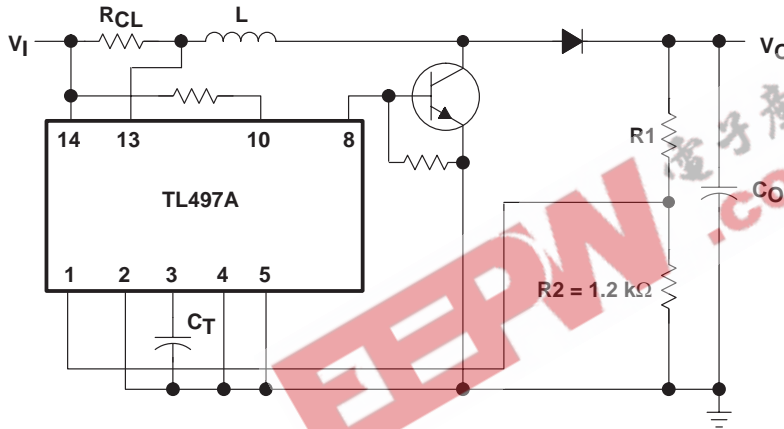

**EXTENDED POWER CONFIGURATION**  
(using external transistor)

- $R_1 = (V_O - 1.2 \text{ V}) \text{ k}\Omega$

- $R_{CL} = \frac{0.5 \text{ V}}{I_{(PK)}}$

- $C_O (\mu\text{F}) \approx t_{on} (\mu\text{s}) \frac{\left[ \frac{V_I}{V_O} I_{(PK)} + I_O \right]}{V_{\text{ripple (PK)}}$

Figure 1. Positive Regulator, Step-Up Configurations

# TL497A 500-mA PEAK STEP-UP, STEP-DOWN, INVERTING SWITCHING VOLTAGE REGULATOR

SLVS009F – JUNE 1976 – REVISED FEBRUARY 2005

## APPLICATION INFORMATION

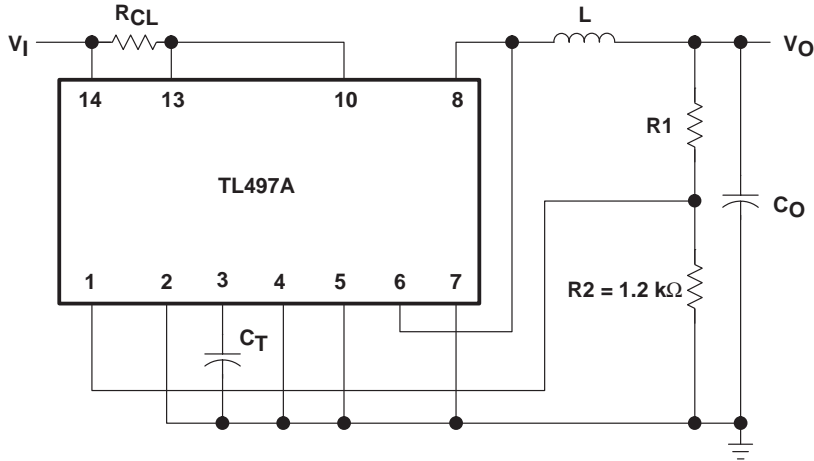

**BASIC CONFIGURATION**  
(Peak Switching Current =  $I_{(PK)} < 500$  mA)

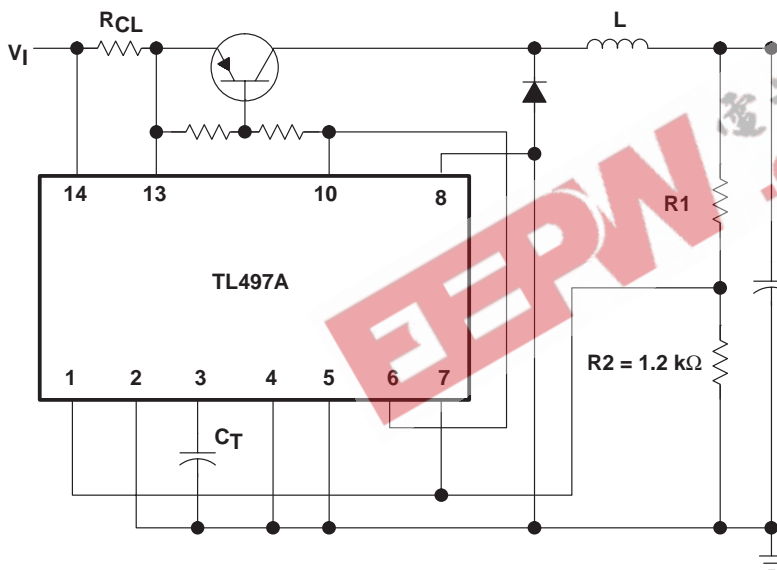

**EXTENDED POWER CONFIGURATION**  
(using external transistor)

### DESIGN EQUATIONS

- $I_{(PK)} = 2 I_{O \text{ max}}$
- $L (\mu\text{H}) = \frac{V_I - V_O}{I_{(PK)}} t_{on}(\mu\text{s})$
- Choose L (50 to 500  $\mu\text{H}$ ), calculate  $t_{on}$  (10 to 150  $\mu\text{s}$ )
- $C_T(\text{pF}) \approx 12 t_{on}(\mu\text{s})$

- $R_1 = (V_O - 1.2 \text{ V}) \text{ k}\Omega$

- $R_{CL} = \frac{0.5 \text{ V}}{I_{(PK)}}$

- $C_O (\mu\text{F}) \approx t_{on}(\mu\text{s}) \frac{\left[ \frac{V_I - V_O}{V_O} I_{(PK)} + I_O \right]}{V_{\text{ripple}}(\text{PK})}$

Figure 2. Positive Regulator, Step-Down Configurations

500-mA PEAK STEP-UP, STEP-DOWN, INVERTING SWITCHING VOLTAGE REGULATOR

SLVS009F – JUNE 1976 – REVISED FEBRUARY 2005

APPLICATION INFORMATION

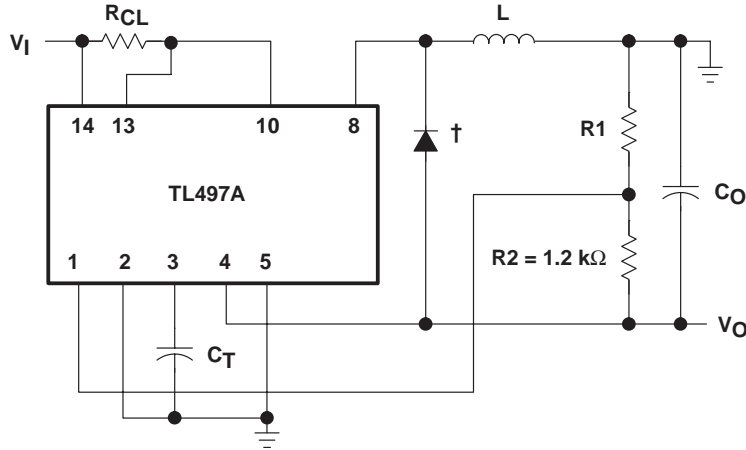

**BASIC CONFIGURATION**  
(Peak Switching Current =  $I_{(PK)} < 500 \text{ mA}$ )

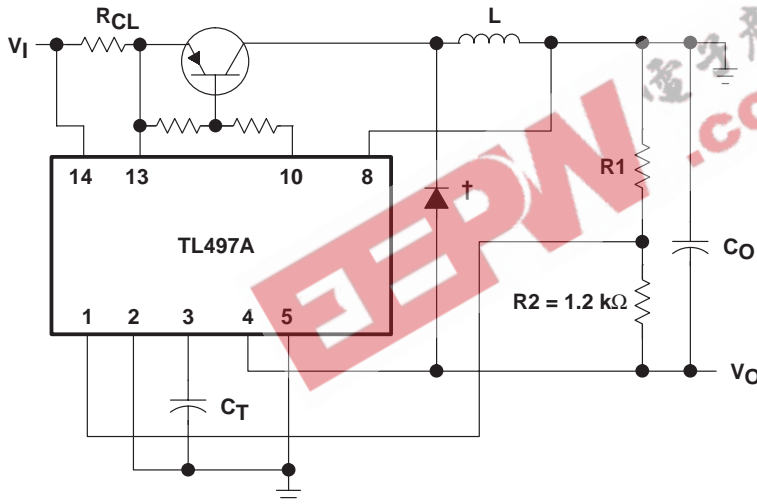

**EXTENDED POWER CONFIGURATION**  
(using external transistor)

DESIGN EQUATIONS

- $I_{(PK)} = 2 I_O \max \left[ 1 + \frac{|V_O|}{V_I} \right]$

- $L (\mu\text{H}) = \frac{V_I}{I_{(PK)}} t_{on} (\mu\text{s})$

Choose L (50 to 500  $\mu\text{H}$ ), calculate  $t_{on}$  (10 to 150  $\mu\text{s}$ )

- $C_T (\text{pF}) \approx 12 t_{on} (\mu\text{s})$

- $R_1 = (|V_O| - 1.2 \text{ V}) \text{ k}\Omega$

- $R_{CL} = \frac{0.5 \text{ V}}{I_{(PK)}}$

- $C_O (\mu\text{F}) \approx t_{on} (\mu\text{s}) \frac{\left[ \frac{V_I}{|V_O|} I_{(PK)} + I_O \right]}{V_{\text{ripple (PK)}}$

† Use external catch diode, e.g., 1N4001, when building an inverting supply with the TL497A.

Figure 3. Inverting Applications

# TL497A 500-mA PEAK STEP-UP, STEP-DOWN, INVERTING SWITCHING VOLTAGE REGULATOR

SLVS009F – JUNE 1976 – REVISED FEBRUARY 2005

## APPLICATION INFORMATION

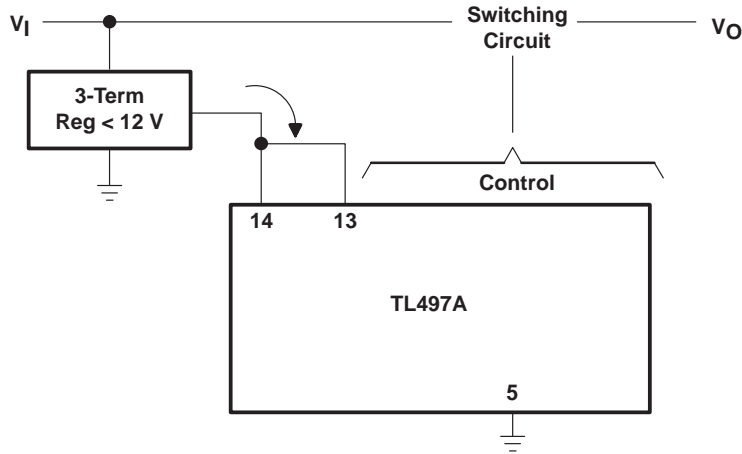

### EXTENDED INPUT CONFIGURATION WITHOUT CURRENT LIMIT

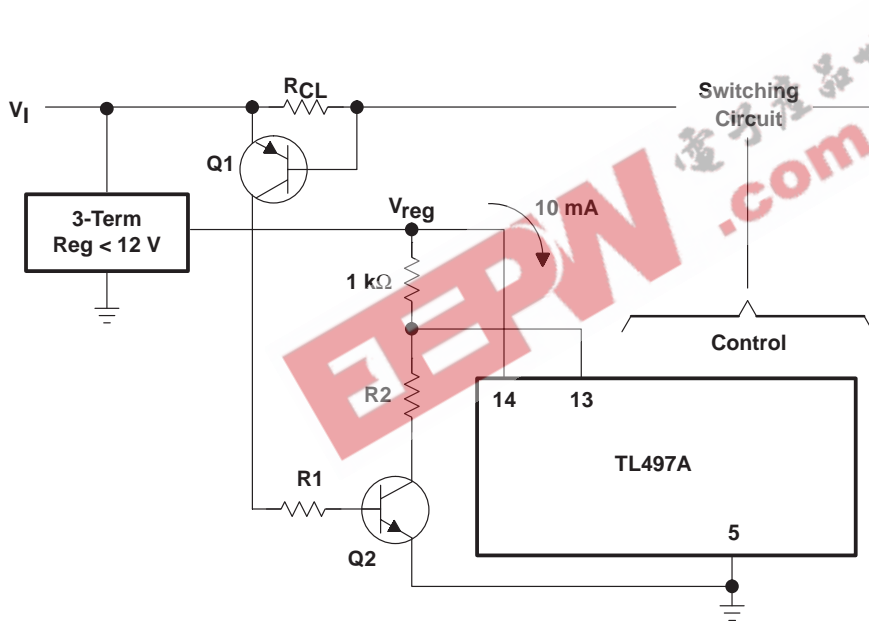

### DESIGN EQUATIONS

- $R_{CL} = \frac{V_{BE}(Q1)}{I_{limit}(PK)}$
- $R1 = \frac{V_I}{I_B(Q2)}$
- $R2 = (V_{reg} - 1) 10\text{ k}\Omega$

### CURRENT LIMIT FOR EXTENDED INPUT CONFIGURATION

Figure 4. Extended Input Voltage Range ( $V_I > 12\text{ V}$ )



**PACKAGING INFORMATION**

Orderable Device	Status <sup>(1)</sup>	Package Type	Package Drawing	Pins	Package Qty	Eco Plan <sup>(2)</sup>	Lead/Ball Finish	MSL Peak Temp <sup>(3)</sup>
TL497ACD	ACTIVE	SOIC	D	14	50	Green (RoHS & no Sb/Br)	CU NIPDAU	Level-1-260C-UNLIM
TL497ACDE4	ACTIVE	SOIC	D	14	50	Green (RoHS & no Sb/Br)	CU NIPDAU	Level-1-260C-UNLIM
TL497ACDR	ACTIVE	SOIC	D	14	2500	Green (RoHS & no Sb/Br)	CU NIPDAU	Level-1-260C-UNLIM
TL497ACDRE4	ACTIVE	SOIC	D	14	2500	Green (RoHS & no Sb/Br)	CU NIPDAU	Level-1-260C-UNLIM
TL497ACN	ACTIVE	PDIP	N	14	25	Pb-Free (RoHS)	CU NIPDAU	N / A for Pkg Type
TL497ACNE4	ACTIVE	PDIP	N	14	25	Pb-Free (RoHS)	CU NIPDAU	N / A for Pkg Type
TL497ACNSLE	OBSOLETE	SO	NS	14		TBD	Call TI	Call TI
TL497ACNSR	ACTIVE	SO	NS	14	2000	Green (RoHS & no Sb/Br)	CU NIPDAU	Level-1-260C-UNLIM
TL497ACNSRE4	ACTIVE	SO	NS	14	2000	Green (RoHS & no Sb/Br)	CU NIPDAU	Level-1-260C-UNLIM
TL497ACPWR	ACTIVE	TSSOP	PW	14	2000	Green (RoHS & no Sb/Br)	CU NIPDAU	Level-1-260C-UNLIM
TL497ACPWRE4	ACTIVE	TSSOP	PW	14	2000	Green (RoHS & no Sb/Br)	CU NIPDAU	Level-1-260C-UNLIM
TL497ACPWRG4	ACTIVE	TSSOP	PW	14	2000	Green (RoHS & no Sb/Br)	CU NIPDAU	Level-1-260C-UNLIM
TL497AID	ACTIVE	SOIC	D	14	50	Green (RoHS & no Sb/Br)	CU NIPDAU	Level-1-260C-UNLIM
TL497AIDE4	ACTIVE	SOIC	D	14	50	Green (RoHS & no Sb/Br)	CU NIPDAU	Level-1-260C-UNLIM
TL497AIDR	ACTIVE	SOIC	D	14	2500	Green (RoHS & no Sb/Br)	CU NIPDAU	Level-1-260C-UNLIM
TL497AIDRE4	ACTIVE	SOIC	D	14	2500	Green (RoHS & no Sb/Br)	CU NIPDAU	Level-1-260C-UNLIM
TL497AIJ	OBSOLETE	CDIP	J	14		TBD	Call TI	Call TI
TL497AIN	ACTIVE	PDIP	N	14	25	Pb-Free (RoHS)	CU NIPDAU	N / A for Pkg Type
TL497AINE4	ACTIVE	PDIP	N	14	25	Pb-Free (RoHS)	CU NIPDAU	N / A for Pkg Type

<sup>(1)</sup> The marketing status values are defined as follows:

**ACTIVE:** Product device recommended for new designs.

**LIFEBUY:** TI has announced that the device will be discontinued, and a lifetime-buy period is in effect.

**NRND:** Not recommended for new designs. Device is in production to support existing customers, but TI does not recommend using this part in a new design.

**PREVIEW:** Device has been announced but is not in production. Samples may or may not be available.

**OBSOLETE:** TI has discontinued the production of the device.

<sup>(2)</sup> Eco Plan - The planned eco-friendly classification: Pb-Free (RoHS), Pb-Free (RoHS Exempt), or Green (RoHS & no Sb/Br) - please check <http://www.ti.com/productcontent> for the latest availability information and additional product content details.

**TBD:** The Pb-Free/Green conversion plan has not been defined.

**Pb-Free (RoHS):** TI's terms "Lead-Free" or "Pb-Free" mean semiconductor products that are compatible with the current RoHS requirements for all 6 substances, including the requirement that lead not exceed 0.1% by weight in homogeneous materials. Where designed to be soldered at high temperatures, TI Pb-Free products are suitable for use in specified lead-free processes.

**Pb-Free (RoHS Exempt):** This component has a RoHS exemption for either 1) lead-based flip-chip solder bumps used between the die and

---

package, or 2) lead-based die adhesive used between the die and leadframe. The component is otherwise considered Pb-Free (RoHS compatible) as defined above.

**Green (RoHS & no Sb/Br):** TI defines "Green" to mean Pb-Free (RoHS compatible), and free of Bromine (Br) and Antimony (Sb) based flame retardants (Br or Sb do not exceed 0.1% by weight in homogeneous material)

<sup>(3)</sup> MSL, Peak Temp. -- The Moisture Sensitivity Level rating according to the JEDEC industry standard classifications, and peak solder temperature.

**Important Information and Disclaimer:**The information provided on this page represents TI's knowledge and belief as of the date that it is provided. TI bases its knowledge and belief on information provided by third parties, and makes no representation or warranty as to the accuracy of such information. Efforts are underway to better integrate information from third parties. TI has taken and continues to take reasonable steps to provide representative and accurate information but may not have conducted destructive testing or chemical analysis on incoming materials and chemicals. TI and TI suppliers consider certain information to be proprietary, and thus CAS numbers and other limited information may not be available for release.

In no event shall TI's liability arising out of such information exceed the total purchase price of the TI part(s) at issue in this document sold by TI to Customer on an annual basis.

**EEPW** 电子產品世界  
.com.cn

J (R-GDIP-T\*\*)  
14 LEADS SHOWN

CERAMIC DUAL IN-LINE PACKAGE



DIM \ PINS **	14	16	18	20
A	0.300 (7,62) BSC	0.300 (7,62) BSC	0.300 (7,62) BSC	0.300 (7,62) BSC
B MAX	0.785 (19,94)	.840 (21,34)	0.960 (24,38)	1.060 (26,92)
B MIN	—	—	—	—
C MAX	0.300 (7,62)	0.300 (7,62)	0.310 (7,87)	0.300 (7,62)
C MIN	0.245 (6,22)	0.245 (6,22)	0.220 (5,59)	0.245 (6,22)



4040083/F 03/03

- NOTES:
- All linear dimensions are in inches (millimeters).
  - This drawing is subject to change without notice.
  - This package is hermetically sealed with a ceramic lid using glass frit.
  - Index point is provided on cap for terminal identification only on press ceramic glass frit seal only.
  - Falls within MIL STD 1835 GDIP1-T14, GDIP1-T16, GDIP1-T18 and GDIP1-T20.

# MECHANICAL DATA

## N (R-PDIP-T\*\*)

## PLASTIC DUAL-IN-LINE PACKAGE

16 PINS SHOWN

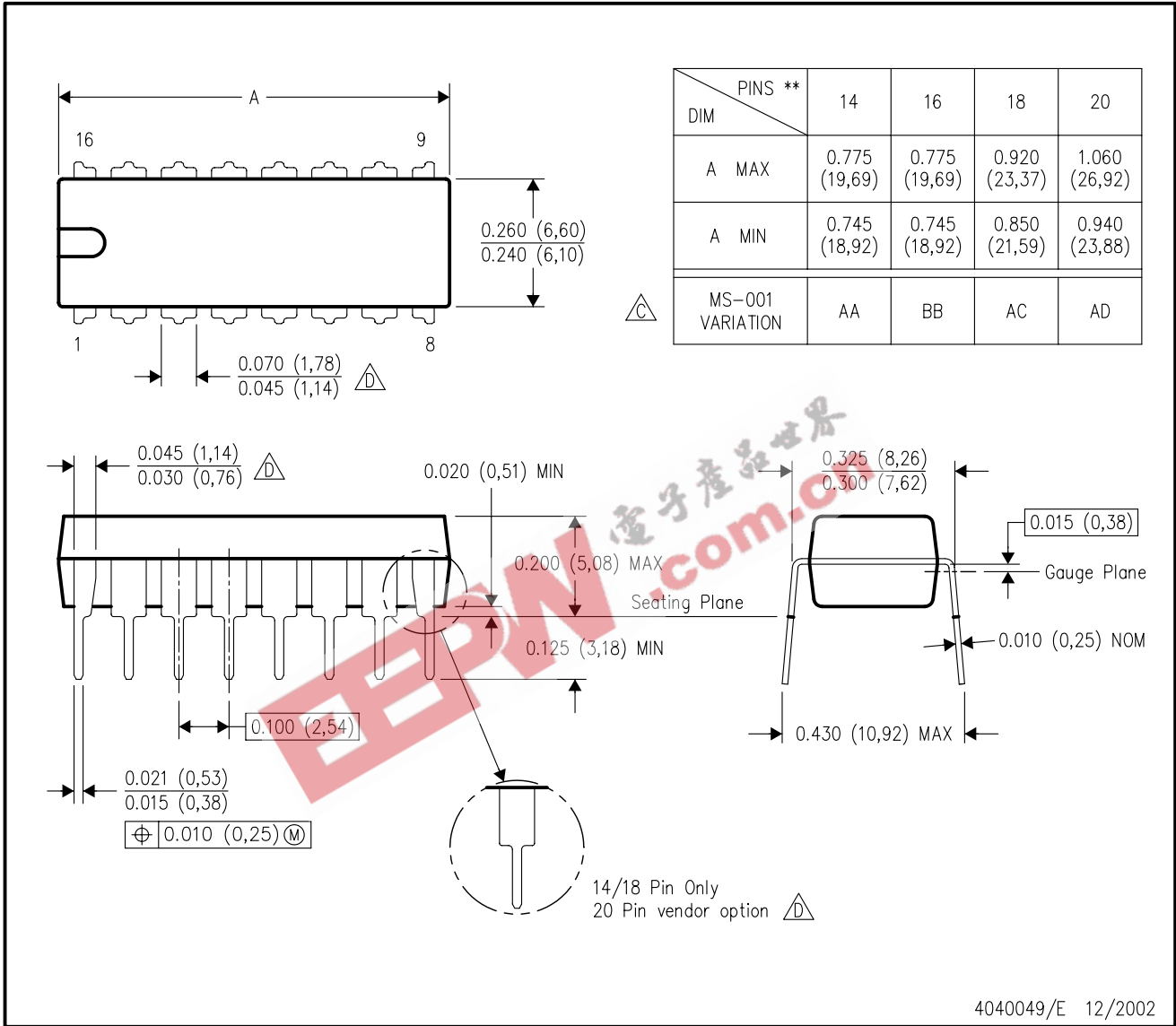

- NOTES:
- A. All linear dimensions are in inches (millimeters).
  - B. This drawing is subject to change without notice.
  - Falls within JEDEC MS-001, except 18 and 20 pin minimum body length (Dim A).
  - The 20 pin end lead shoulder width is a vendor option, either half or full width.

# MECHANICAL DATA

## D (R-PDSO-G14)

## PLASTIC SMALL-OUTLINE PACKAGE

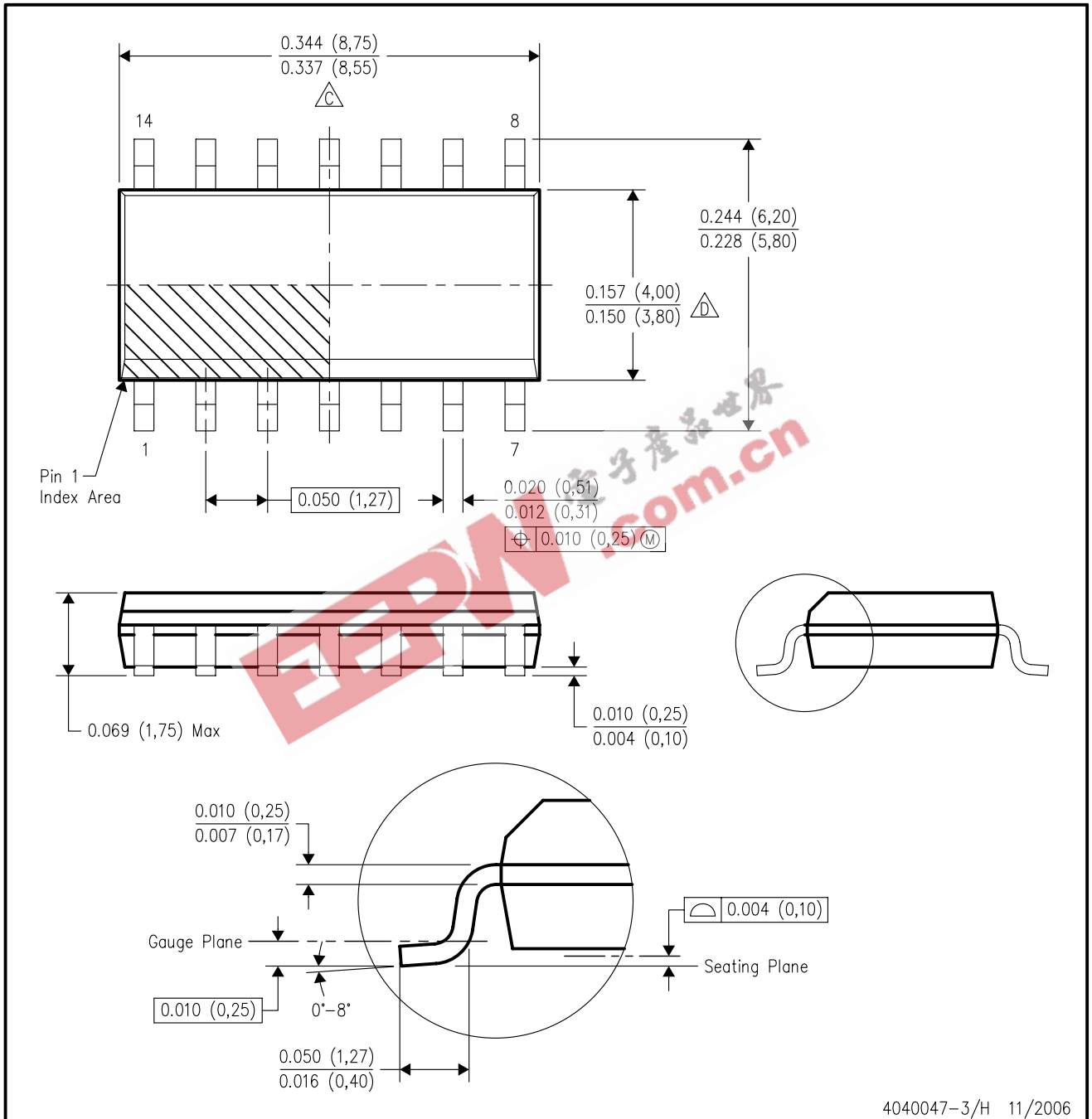

- NOTES:
- A. All linear dimensions are in inches (millimeters).
  - B. This drawing is subject to change without notice.
  - C. Body length does not include mold flash, protrusions, or gate burrs. Mold flash, protrusions, or gate burrs shall not exceed .006 (0,15) per end.
  - D. Body width does not include interlead flash. Interlead flash shall not exceed .017 (0,43) per side.
  - E. Reference JEDEC MS-012 variation AB.

## MECHANICAL DATA

**NS (R-PDSO-G\*\*)**

**PLASTIC SMALL-OUTLINE PACKAGE**

**14-PINS SHOWN**

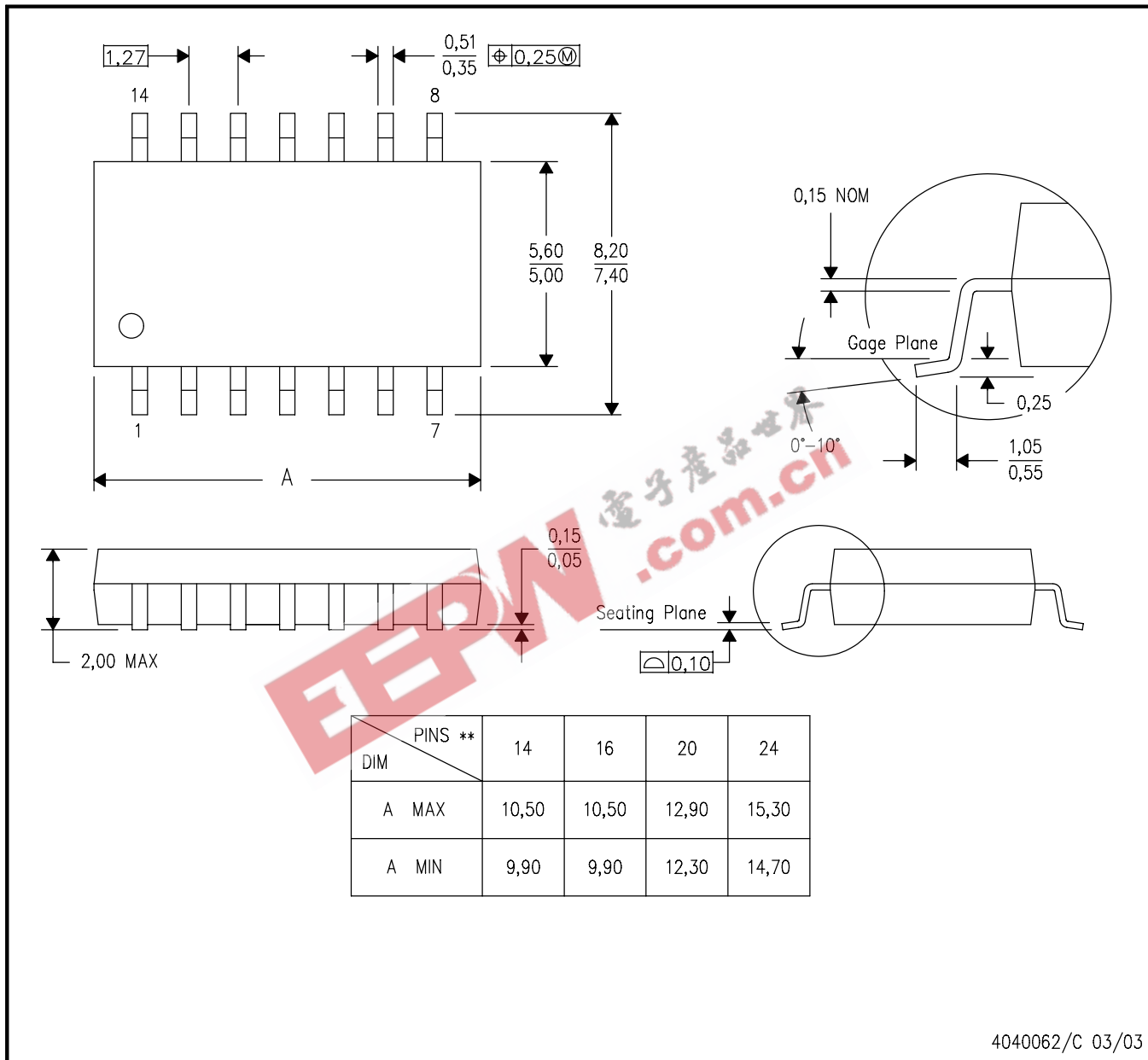

- NOTES:
- A. All linear dimensions are in millimeters.
  - B. This drawing is subject to change without notice.
  - C. Body dimensions do not include mold flash or protrusion, not to exceed 0,15.

# MECHANICAL DATA

MTSS001C – JANUARY 1995 – REVISED FEBRUARY 1999

PW (R-PDSO-G\*\*)

PLASTIC SMALL-OUTLINE PACKAGE

14 PINS SHOWN

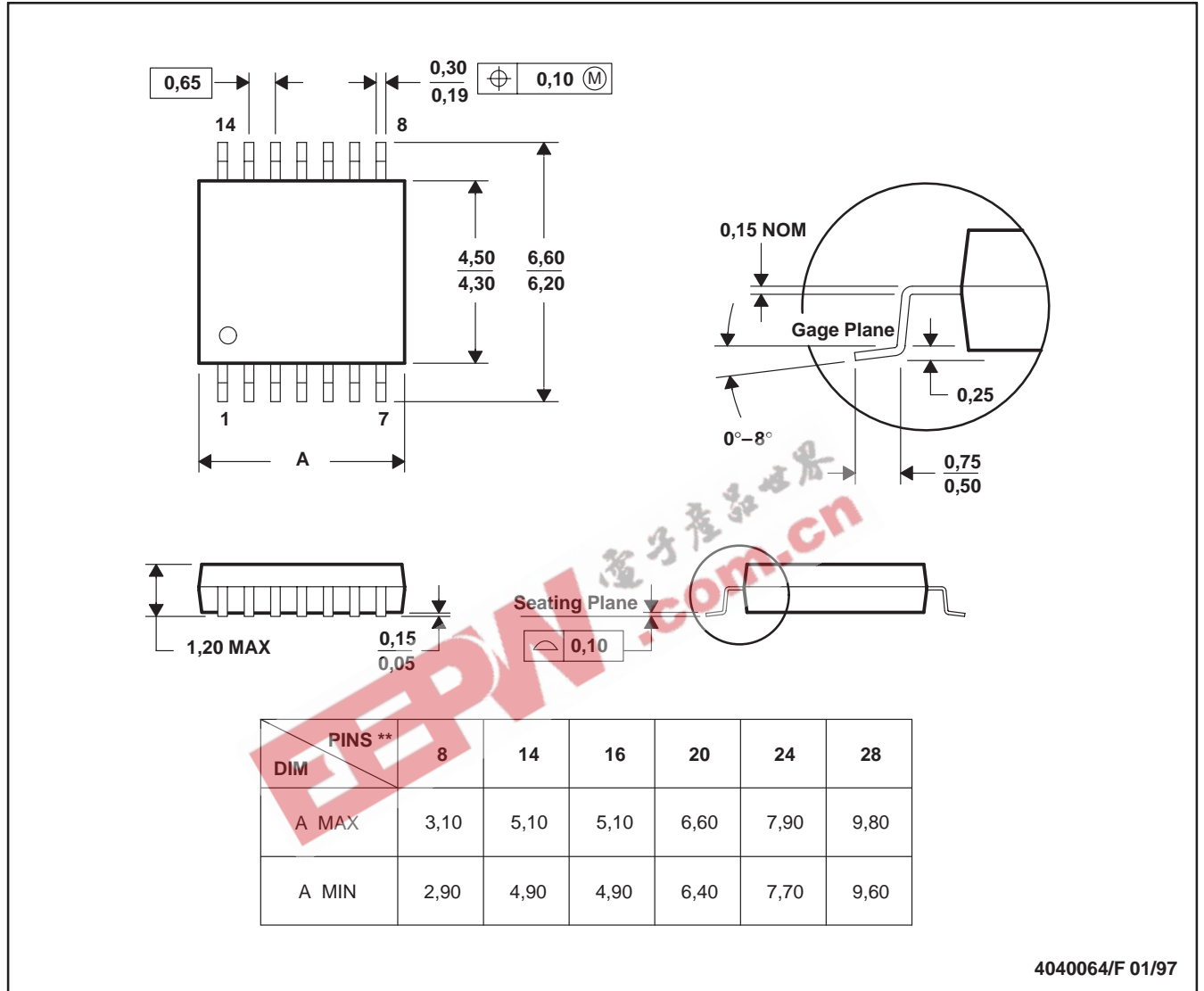

4040064/F 01/97

- NOTES: A. All linear dimensions are in millimeters.  
 B. This drawing is subject to change without notice.  
 C. Body dimensions do not include mold flash or protrusion not to exceed 0,15.  
 D. Falls within JEDEC MO-153

## IMPORTANT NOTICE

Texas Instruments Incorporated and its subsidiaries (TI) reserve the right to make corrections, modifications, enhancements, improvements, and other changes to its products and services at any time and to discontinue any product or service without notice. Customers should obtain the latest relevant information before placing orders and should verify that such information is current and complete. All products are sold subject to TI's terms and conditions of sale supplied at the time of order acknowledgment.

TI warrants performance of its hardware products to the specifications applicable at the time of sale in accordance with TI's standard warranty. Testing and other quality control techniques are used to the extent TI deems necessary to support this warranty. Except where mandated by government requirements, testing of all parameters of each product is not necessarily performed.

TI assumes no liability for applications assistance or customer product design. Customers are responsible for their products and applications using TI components. To minimize the risks associated with customer products and applications, customers should provide adequate design and operating safeguards.

TI does not warrant or represent that any license, either express or implied, is granted under any TI patent right, copyright, mask work right, or other TI intellectual property right relating to any combination, machine, or process in which TI products or services are used. Information published by TI regarding third-party products or services does not constitute a license from TI to use such products or services or a warranty or endorsement thereof. Use of such information may require a license from a third party under the patents or other intellectual property of the third party, or a license from TI under the patents or other intellectual property of TI.

Reproduction of information in TI data books or data sheets is permissible only if reproduction is without alteration and is accompanied by all associated warranties, conditions, limitations, and notices. Reproduction of this information with alteration is an unfair and deceptive business practice. TI is not responsible or liable for such altered documentation.

Resale of TI products or services with statements different from or beyond the parameters stated by TI for that product or service voids all express and any implied warranties for the associated TI product or service and is an unfair and deceptive business practice. TI is not responsible or liable for any such statements.

Following are URLs where you can obtain information on other Texas Instruments products and application solutions:

<b>Products</b>		<b>Applications</b>	
Amplifiers	<a href="http://amplifier.ti.com">amplifier.ti.com</a>	Audio	<a href="http://www.ti.com/audio">www.ti.com/audio</a>
Data Converters	<a href="http://dataconverter.ti.com">dataconverter.ti.com</a>	Automotive	<a href="http://www.ti.com/automotive">www.ti.com/automotive</a>
DSP	<a href="http://dsp.ti.com">dsp.ti.com</a>	Broadband	<a href="http://www.ti.com/broadband">www.ti.com/broadband</a>
Interface	<a href="http://interface.ti.com">interface.ti.com</a>	Digital Control	<a href="http://www.ti.com/digitalcontrol">www.ti.com/digitalcontrol</a>
Logic	<a href="http://logic.ti.com">logic.ti.com</a>	Military	<a href="http://www.ti.com/military">www.ti.com/military</a>
Power Mgmt	<a href="http://power.ti.com">power.ti.com</a>	Optical Networking	<a href="http://www.ti.com/opticalnetwork">www.ti.com/opticalnetwork</a>
Microcontrollers	<a href="http://microcontroller.ti.com">microcontroller.ti.com</a>	Security	<a href="http://www.ti.com/security">www.ti.com/security</a>
Low Power Wireless	<a href="http://www.ti.com/lpw">www.ti.com/lpw</a>	Telephony	<a href="http://www.ti.com/telephony">www.ti.com/telephony</a>
		Video & Imaging	<a href="http://www.ti.com/video">www.ti.com/video</a>
		Wireless	<a href="http://www.ti.com/wireless">www.ti.com/wireless</a>

Mailing Address: Texas Instruments  
Post Office Box 655303 Dallas, Texas 75265