

# UTC TL1451 LINEAR INTEGRATED CIRCUIT

## DUAL PULSE-WIDTH-MODULATION CONTROL CIRCUITS

### DESCRIPTION

The UTC TL1451 incorporates on a single monolithic chip all the functions required in the construction of two pulse-width-modulation (PWM) control circuits. Designed primarily for power supply control, the TL1451 contains an on-chip 2.5V regulator, two error amplifiers, an adjustable oscillator, two dead-time comparators, undervoltage lockout circuitry, and dual common-emitter output transistor circuits.

### FEATURES

- \*Complete PWM Power control Circuitry
- \*Completely Synchronized Operation
- \*Internal Undervoltage Lockout Protection
- \*Wide Supply Voltage Range
- \*Internal Short-Circuit Protection
- \*Oscillator Frequency .500kHz Max
- \*Variable Dead Time Provides Control Over Total Range
- \*Internal Regulator Provides a Stable 2.5V Reference Supply

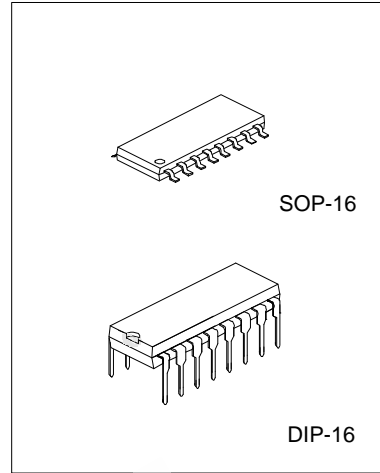

### PIN CONFIGURATIONS

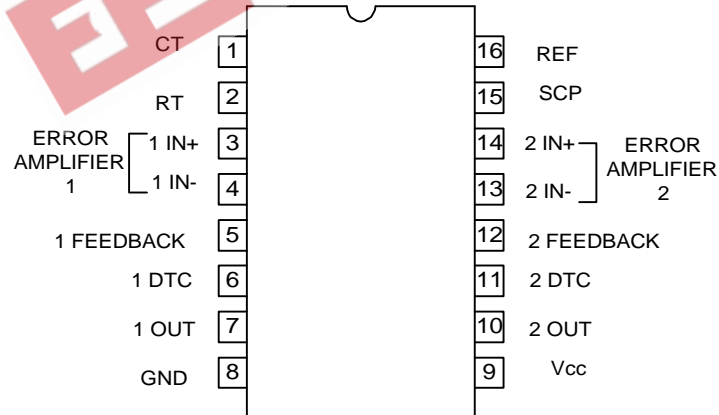

# UTC TL1451 LINEAR INTEGRATED CIRCUIT

## BLOCK DIAGRAM

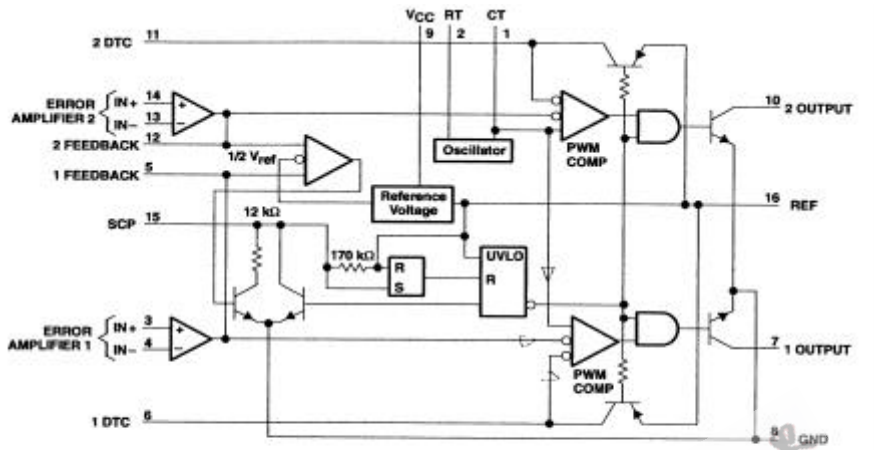

EEPW.com.cn 电子产品世界

# UTC TL1451 LINEAR INTEGRATED CIRCUIT

ABSOLUTE MAXIMUM RATINGS(Unless otherwise noted all is over operating free air temperature range)

PARAMETER	SYMBOL	VALUE	UNIT
Supply Voltage	$V_{CC}$	51	V
Amplifier Input Voltage	$V_I$	20	V
Collector Output Voltage	$V_O$	51	V
Collector Output Current	$I_O$	21	mA
Power Dissipation : $T_A \leq 25^\circ\text{C}$			mW
DIP		1000	
SOP		500	
Operating free-air Temperature Range	$T_A$	-20 TO 85	$^\circ\text{C}$
Storage Temperature Range	$T_{stg}$	-65 TO 150	$^\circ\text{C}$
Lead Temperature 1.6mm from Case for 10 Sec.	$T_{case}$	260	$^\circ\text{C}$

## RECOMMENDED OPERATING CONDITIONS

PARAMETER	SYMBOL	VALUE		UNIT
		MIN	MAX	
Supply Voltage	$V_{CC}$	3.6	50	V
Amplifier Input Voltage	$V_I$	1.05	1.45	V
Collector Output Voltage	$V_O$		50	V
Collector Output Current(each Transistor)	$I_O$		20	mA
Current into Feedback Terminal			45	$\mu\text{A}$
Feedback Resistor	$R_F$	100		$\text{k}\Omega$
Timing Capacitor	$C_T$	150	15000	pF
Timing Resistor	$R_T$	5.1	100	$\text{k}\Omega$
Oscillator frequency		1	500	kHz
Operating Free-Air Temperature	$T_A$	-20	85	$^\circ\text{C}$

## ELECTRICAL CHARACTERISTICS

(Over recommended operating free-air temperature range,  $V_{CC}=6\text{V}$ ,  $f=200\text{kHz}$ ,  $T_A=25^\circ\text{C}$ , Unless otherwise specified)

PARAMETER	TEST CONDITIONS	MIN	TYP	MAX	UNIT
<b>Reference Section</b>					
Output Voltage	$I_O=1\text{mA}$	2.4	2.5	2.6	V
Output Voltage Change with Temperature	$T_A=-20^\circ\text{C}$ to $25^\circ\text{C}$ $T_A=25^\circ\text{C}$ to $85^\circ\text{C}$		-0.1	$\pm 1\%$	
			-0.2	$\pm 1\%$	
Input Voltage Regulation	$V_{CC}=3.6\text{V}$ to $40\text{V}$		2	12.5	mV
Output Voltage Regulation	$I_O=0.1\text{mA}$ to $1\text{mA}$		1	7.5	mV
Short-Circuit Output Current	$V_O=0$	3	10	30	mA
<b>Undervoltage Lockout Section</b>					
Upper Threshold Voltage ( $V_{CC}$ )	$I_O(\text{ref})=0.1\text{mA}$ , $T_A=25^\circ\text{C}$		2.72		V
Lower Threshold Voltage ( $V_{CC}$ )			2.6		V
Hysteresis ( $V_{CC}$ )		80	120		mV
Reset Threshold voltage ( $V_{CC}$ )		1.5	1.9		V
<b>Short-Circuit Protection Control Section</b>					
Input Threshold Voltage(SCP)	$T_A=25^\circ\text{C}$	0.65	0.7	0.75	V

UTC UNISONIC TECHNOLOGIES CO., LTD. 3

QW-R103-011,A

# UTC TL1451 LINEAR INTEGRATED CIRCUIT

PARAMETER	TEST CONDITIONS	MIN	TYP	MAX	UNIT
Standby Voltage(SCP)	No pullup	140	185	230	mV
Latched Input Voltage (SCP)	No pullup		60	120	mV
Input (source) Current	VI=0.7V,TA=25°C	-10	-15	-20	μA
Comparator Threshold Voltage (FEEDBACK)			1.18		V
<b>Oscillator Section</b>					
Frequency	CT=330pF, RT=10kΩ		200		kHz
Standard deviation of frequency	CT=330pF, RT=10kΩ		10%		
Frequency Change with Voltage	Vcc=3.6V to 40V		1%		
Frequency Change with Temperature	TA=-20°C to 25°C TA=25°C to 85°C		-0.4% -0.2%	±2% ±2%	
<b>Dead-Time Control Section</b>					
Input bias Current (DTC)				1	μA
Latch mode (source) Current (DTC)	TA=25°C	-80	-145		μA
Latched Input Voltage (DTC)	Io=40μA	2.3			V
Input threshold Voltage at f=10kHz (DTC)	Zero duty cycle Maximum duty cycle	1.2	2.05 1.45	2.25	V
<b>Error-Amplifier Section</b>					
Input Offset Voltage	Vo (FEEDBACK)=1.25V			±6	mV
Input Offset Current	Vo (FEEDBACK)=1.25V			±100	nA
Input Bias current	Vo (FEEDBACK)=1.25V		160	500	nA
Common-Mode Input Voltage Range	Vcc=3.6V to 40V	1.05 to 1.45			V
Open-loop Voltage Amplification	RF=200kΩ	70	80		dB
Unity-gain Bandwidth			1.5		MHz
Common-mode Rejection Ratio		60	80		dB
Positive Output Voltage Swing		Vref- 0.1			V
Negative Output Voltage Swing				1	V
Output (sink) Current (FEEDBACK)	VID=-0.1V,Vo=1.25V	0.5	1.6		mA
Output (source) Current (FEEDBACK)	VID=-0.1V,Vo=1.25V	-45	-70		μA
<b>Output Section</b>					
Collector off-state Current	Vo=50V			10	μA
Output Saturation Voltage	Io=10mA		1.2	2	V
Short-Circuit Output Current	Vo=6V		90		mA
<b>PWM Comparator Section</b>					
Input Threshold Voltage at f=10kHz (FEEDBACK)	Zero duty cycle Maximum duty cycle	1.2	2.05 1.45	2.25	V
<b>TOTAL DEVICE</b>					
Standby Supply Current	Off-state		1.3	1.8	mA
Average Supply Current	RT=10kΩ		1.7	2.4	mA

# UTC TL1451 LINEAR INTEGRATED CIRCUIT

## TEST CIRCUIT

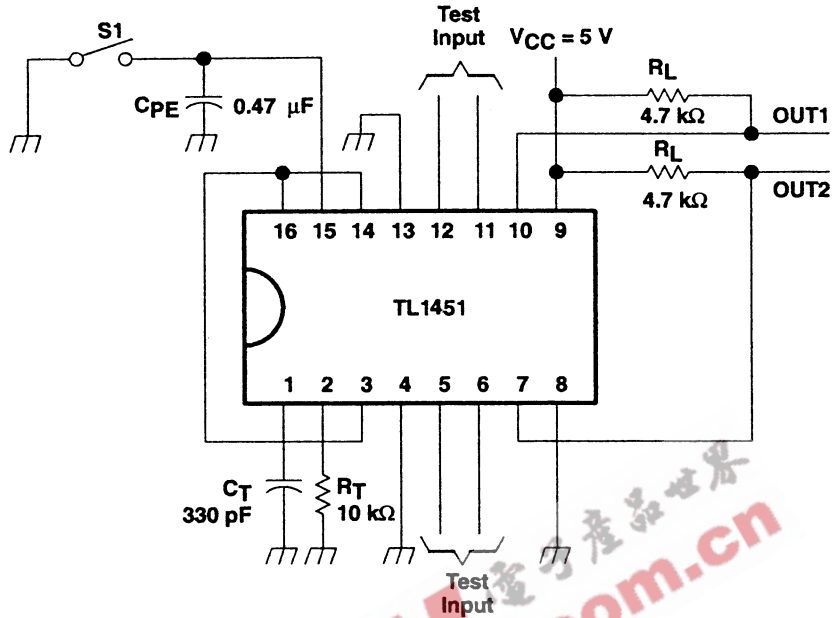

## TIMING DIAGRAM

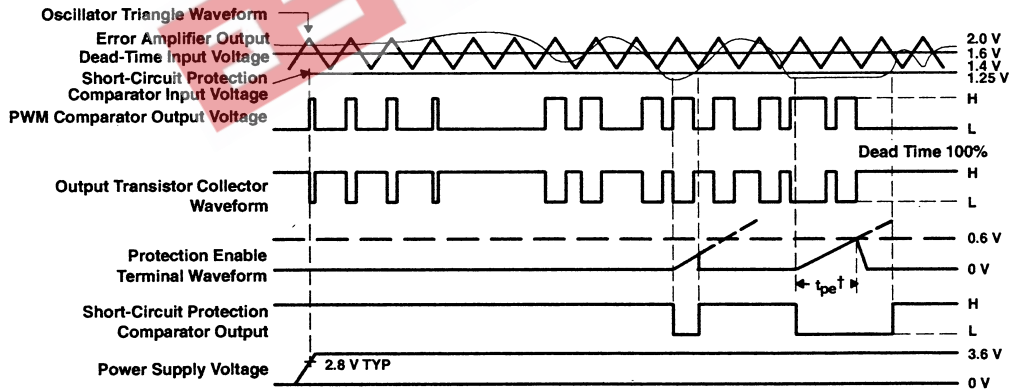

† Protection Enable Time,  $t_{pe} = (0.051 \times 10^6 \times C_{pe})$  in seconds