

## TL493, TL494, TL495 PULSE-WIDTH-MODULATION CONTROL CIRCUITS

D2535, JANUARY 1983—REVISED OCTOBER 1988

- Complete PWM Power Control Circuitry
- Uncommitted Outputs for 200-mA Sink or Source Current
- Output Control Selects Single-Ended or Push-Pull Operation
- Internal Circuitry Prohibits Double Pulse at Either Output
- Variable Dead-Time Provides Control over Total Range
- Internal Regulator Provides a Stable 5-V Reference Supply, 5%
- Circuit Architecture Allows Easy Synchronization
- TL493 has Output Current-Limit Sensing
- TL495 has On-Chip 39-V Zener and External Control of Output Steering

### description

The TL493, TL494, and TL495 each incorporate on a single monolithic chip all the functions required in the construction of a pulse-width-modulation control circuit. Designed primarily for power supply control, these devices offer the systems engineer the flexibility to tailor the power supply control circuitry to his application.

The TL493 contains an error amplifier, current-limiting amplifier, an on-chip adjustable oscillator, a dead-time control comparator, pulse-steering control flip-flop, a 5-volt, 5%-precision regulator, and output-control circuits.

The error amplifier exhibits a common-mode voltage range from  $-0.3$  volts to  $V_{CC} - 2$  volts. The current-limit amplifier exhibits a common-mode voltage range from  $-0.3$  volts to 3 volts with an offset voltage of approximately 80 millivolts in series with the inverting input to ease circuit design requirements. The dead-time control comparator has a fixed offset that provides approximately 5% dead time when externally altered. The on-chip oscillator may be bypassed by terminating  $R_T$  (pin 6) to the reference output and providing a sawtooth input to  $C_T$  (pin 5), or it may be used to drive the common circuits in synchronous multiple-rail power supplies.

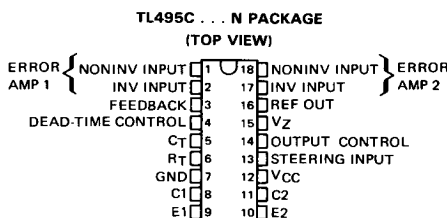
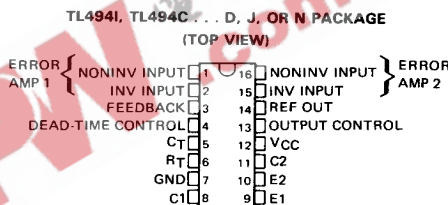
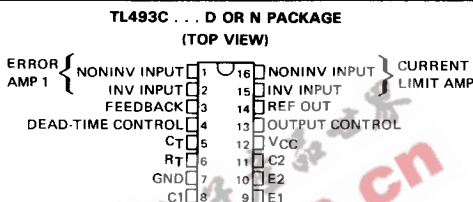

### DEVICE TYPES, SUFFIX VERSIONS, AND PACKAGES

	TL493	TL494	TL495
TL49-I	*	D, J, N	*
TL49-C	D, N	D, J, N	N

\*These combinations are not defined by this data sheet.

### FUNCTION TABLE

INPUTS		OUTPUT FUNCTION
OUTPUT CONTROL	STEERING INPUT (TL495 only)	
$V_I = 0$	Open	Single-ended or parallel output
$V_I = V_{ref}$	Open	Normal push-pull operation
$V_I = V_{ref}$	$V_I = 0$	PWM Output at Q1
$V_I = V_{ref}$	$V_I = V_{ref}$	PWM Output at Q2

## TL493, TL494, TL495 PULSE-WIDTH-MODULATION CONTROL CIRCUITS

### description (continued)

The uncommitted output transistors provide either common-emitter or emitter-follower output capability. Each device provides for push-pull or single-ended output operation, which may be selected through the output-control function. The architecture of these devices prohibits the possibility of either output being pulsed twice during push-pull operation.

The TL493 and TL494 are similar except that an additional error amplifier is included in the TL494 instead of a current-limiting amplifier. The TL495 provides the identical functions found in the TL494. In addition, it contains an on-chip 39-volt diode for high-voltage applications where  $V_{CC}$  is greater than 40 volts, and an output-steering control that overrides the internal control of the pulse-steering flip-flop.

The TL494I is characterized for operation from  $-25^{\circ}\text{C}$  to  $85^{\circ}\text{C}$ . The TL493C, TL494C, and TL495C are characterized for operation from  $0^{\circ}\text{C}$  to  $70^{\circ}\text{C}$ .

2

Data Sheets

### functional block diagram

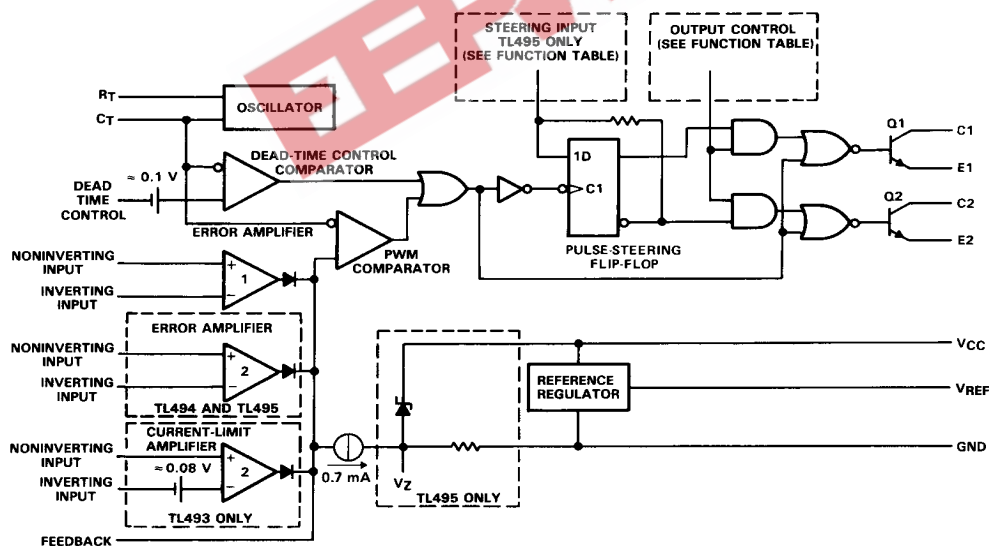

**TL493, TL494, TL495  
PULSE-WIDTH-MODULATION CONTROL CIRCUITS**

**absolute maximum ratings over operating free-air temperature range (unless otherwise noted)**

	TL494I	TL493C TL494C	TL495C	UNIT
Supply voltage, $V_{CC}$ (see Note 1)	41	41	41	V
Amplifier input voltage	$V_{CC} + 0.3$	$V_{CC} + 0.3$	$V_{CC} + 0.3$	V
Collector output voltage	41	41	41	V
Collector output current	250	250	250	mA
Continuous total dissipation	See Dissipation Rating Table			
Operating free-air temperature range	-25 to 85	0 to 70	0 to 70	°C
Storage temperature range	-65 to 150	-65 to 150	-65 to 150	°C
Lead temperature 1,6 mm (1/16 inch) from case for 60 seconds: J package	300	300	300	°C
Lead temperature 1,6 mm (1/16 inch) from case for 10 seconds: D or N package	260	260	260	°C

NOTE 1: All voltage values, except differential voltages, are with respect to the network ground terminal.

**DISSIPATION RATING TABLE**

PACKAGE	$T_A \leq 25^\circ\text{C}$	DERATING FACTOR	DERATE ABOVE $T_A$	$T_A = 70^\circ\text{C}$	$T_A = 85^\circ\text{C}$
	POWER RATING			POWER RATING	POWER RATING
D	900	7.6 mW/°C	25°C	608 mW	494 mW
J	1000	8.2 mW/°C	28°C	656 mW	533 mW
N	1000	9.2 mW/°C	41°C	736 mW	598 mW

**recommended operating conditions**

	TL494I		TL493C TL494C TL495C		UNIT
	MIN	MAX	MIN	MAX	
Supply voltage, $V_{CC}$	7	40	7	40	V
Amplifier input voltages, $V_I$	-0.3	$V_{CC} - 2$	-0.3	$V_{CC} - 2$	V
Collector output voltage, $V_O$	40		40		V
Collector output current (each transistor)	200		200		mA
Current into feedback terminal	0.3		0.3		mA
Timing capacitor, $C_T$	0.47	10 000	0.47	10 000	nF
Timing resistor, $R_T$	1.8	500	1.8	500	kΩ
Oscillator frequency	1	300	1	300	kHz
Operating free-air temperature, $T_A$	-25	85	0	70	°C

**2**  
Data Sheets

## TL493, TL494, TL495 PULSE-WIDTH-MODULATION CONTROL CIRCUITS

electrical characteristics over recommended operating free-air temperature range,  $V_{CC} = 15\text{ V}$ ,  
 $f = 10\text{ kHz}$  (unless otherwise noted)

### reference section

PARAMETER	TEST CONDITIONS†	TL493C TL494I, TL494C TL495C			UNIT
		MIN	TYP‡	MAX	
Output voltage ( $V_{ref}$ )	$I_O = 1\text{ mA}$	4.75	5	5.25	V
Input regulation	$V_{CC} = 7\text{ V to }40\text{ V}$		2	25	mV
Output regulation	$I_O = 1\text{ to }10\text{ mA}$		1	15	mV
Output voltage change with temperature	$\Delta T_A = \text{MIN to MAX}$		0.2%	1%	
Short-circuit output current§	$V_{ref} = 0$		35		mA

### oscillator section (see Figure 1)

PARAMETER	TEST CONDITIONS†	TL493C TL494I, TL494C TL495C			UNIT
		MIN	TYP‡	MAX	
Frequency	$C_T = 0.01\text{ }\mu\text{F}$ , $R_T = 12\text{ k}\Omega$		10		kHz
Standard deviation of frequency¶	All values of $V_{CC}$ , $C_T$ , $R_T$ , and $T_A$ constant		10%		
Frequency change with voltage	$V_{CC} = 7\text{ V to }40\text{ V}$ , $T_A = 25^\circ\text{C}$		0.1%		
Frequency change with temperature#	$C_T = 0.01\text{ }\mu\text{F}$ , $R_T = 12\text{ k}\Omega$ , $\Delta T_A = \text{MIN to MAX}$			1%	

### amplifier sections (see Figure 2)

PARAMETER		TEST CONDITIONS	MIN	TYP‡	MAX	UNIT
Input offset voltage	Error	$V_O(\text{pin } 3) = 2.5\text{ V}$		2	10	mV
	Current-limit (TL493 only)			80		
Input offset current		$V_O(\text{pin } 3) = 2.5\text{ V}$		25	250	nA
Input bias current		$V_O(\text{pin } 3) = 2.5\text{ V}$		0.2	1	$\mu\text{A}$
Common-mode input voltage range	Error	$V_{CC} = 7\text{ V to }40\text{ V}$		-0.3 to $V_{CC} - 2$		V
	Current limit (TL493 only)			-0.3 to 3		
Open-loop voltage amplification	Error	$\Delta V_O = 3\text{ V}$ , $R_L = 2\text{ k}\Omega$ , $V_O = 0.5\text{ V to }3.5\text{ V}$		70	95	dB
	Current-limit (TL493 only)			90		
Unity-gain bandwidth		$V_O = 0.5\text{ V to }3.5\text{ V}$ , $R_L = 2\text{ k}\Omega$		800		kHz
Common-mode rejection ratio	Error	$\Delta V_O = 40\text{ V}$ , $T_A = 25^\circ\text{C}$		65	80	dB
	Current-limit (TL493 only)			70		
Output sink current (pin 3)		$V_{ID} = -15\text{ mV to }-5\text{ V}$ , $V(\text{pin } 3) = 0.7\text{ V}$		0.3	0.7	mA
Output source current (pin 3)		$V_{ID} = 15\text{ mV to }5\text{ V}$ , $V(\text{pin } 3) = 3.5\text{ V}$		-2		mA

† For conditions shown as MIN or MAX, use the appropriate value specified under recommended operating conditions.

‡ All typical values except for parameter changes with temperature are at  $T_A = 25^\circ\text{C}$ .

§ Duration of the short-circuit should not exceed one second.

¶ Standard deviation is a measure of the statistical distribution about the mean as derived from the formula  $\sigma = \sqrt{\frac{\sum (x_n - \bar{X})^2}{n - 1}}$

# Temperature coefficient of timing capacitor and timing resistor not taken into account.

## TL493, TL494, TL495 PULSE-WIDTH-MODULATION CONTROL CIRCUITS

electrical characteristics over recommended operating free-air temperature range,  $V_{CC} = 15\text{ V}$ ,  $f = 10\text{ kHz}$  (unless otherwise noted)

### output section

PARAMETER	TEST CONDITIONS	TL493C TL494, TL494C TL495C			UNIT
		MIN	TYP†	MAX	
Collector off-state current	$V_{CE} = 40\text{ V}$ , $V_{CC} = 40\text{ V}$		2	100	$\mu\text{A}$
Emitter off-state current	$V_{CC} = V_C = 40\text{ V}$ , $V_E = 0$			-100	$\mu\text{A}$
Collector-emitter saturation voltage	$V_E = 0$ , $I_C = 200\text{ mA}$		1.1	1.3	V
Output control input current	$V_C = 15\text{ V}$ , $I_E = -200\text{ mA}$		1.5	2.5	
	$V_I = V_{ref}$			3.5	mA

### dead-time control-section (see Figure 1)

PARAMETER	TEST CONDITIONS	MIN	TYP	MAX	UNIT
Input bias current (pin 4)	$V_I = 0\text{ to }5.25\text{ V}$		-2	-10	$\mu\text{A}$
Maximum duty cycle, each output	$V_I(\text{pin } 4) = 0$ , $C_T = 0.1\ \mu\text{F}$ , $R_T = 12\ \text{k}\Omega$		45%		
Input threshold voltage (pin 4)	Zero duty cycle		3	3.3	V
	Maximum duty cycle	0			

### pwm comparator section (see Figure 1)

PARAMETER	TEST CONDITIONS	MIN	TYP†	MAX	UNIT
Input threshold voltage (pin 3)	Zero duty cycle		4	4.5	V
Input sink current (pin 3)	$V_{(\text{pin } 3)} = 0.7\text{ V}$	0.3	0.7		mA

### steering control (TL495 only)

PARAMETER	TEST CONDITIONS	MIN	MAX	UNIT
Input current	$V_I = 0.4\text{ V}$		-200	$\mu\text{A}$
	$V_I = 2.4\text{ V}$		200	

### zener-diode circuit (TL495 only)

PARAMETER	TEST CONDITIONS	MIN	TYP†	MAX	UNIT
Breakdown voltage	$V_{CC} = 41\text{ V}$ , $I_Z = 2\text{ mA}$		39		V
Sink current	$V_{I(\text{pin } 15)} = 1\text{ V}$		0.3		mA

### total device

PARAMETER	TEST CONDITIONS	MIN	TYP†	MAX	UNIT
Standby supply current	Pin 6 at $V_{ref}$ , All other inputs and outputs open	$V_{CC} = 15\text{ V}$	6	10	mA
		$V_{CC} = 40\text{ V}$	9	15	
Average supply current	$V_{I(\text{pin } 4)} = 2\text{ V}$ , See Figure 1		7.5		mA

### switching characteristics, $T_A = 25^\circ\text{C}$

PARAMETER	TEST CONDITIONS	MIN	TYP†	MAX	UNIT
Output voltage rise time	Common-emitter configuration, See Figure 3		100	200	ns
Output voltage fall time		25	100	ns	
Output voltage rise time	Emitter-follower configuration, See Figure 4		100	200	ns
Output voltage fall time		40	100	ns	

†All typical values except for temperature coefficient are at  $T_A = 25^\circ\text{C}$ .

2  
Data Sheets

**TL493, TL494, TL495**  
**PULSE-WIDTH-MODULATION CONTROL CIRCUITS**

**PARAMETER MEASUREMENT INFORMATION**

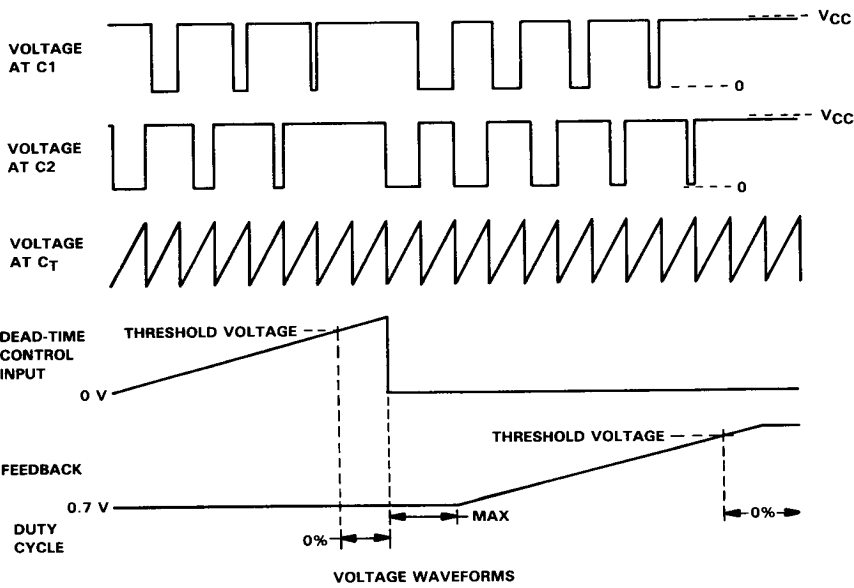
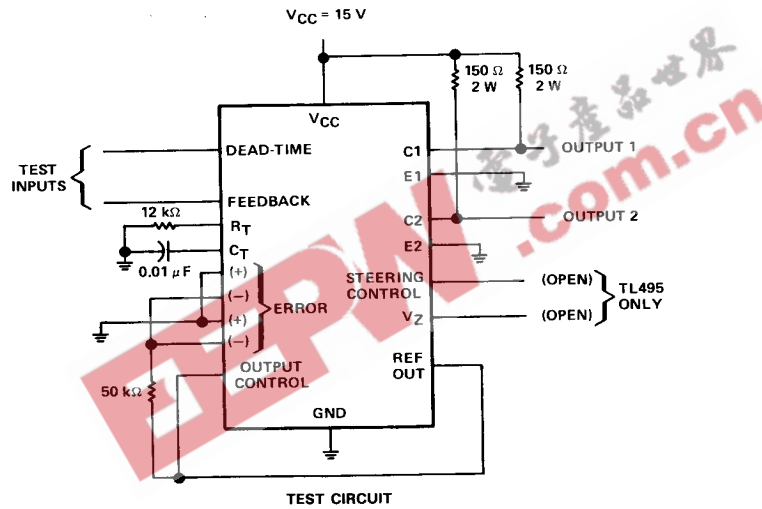

**FIGURE 1. OPERATIONAL TEST CIRCUIT AND WAVEFORMS**

TL493, TL494, TL495  
PULSE-WIDTH-MODULATION CONTROL CIRCUITS

PARAMETER MEASUREMENT INFORMATION

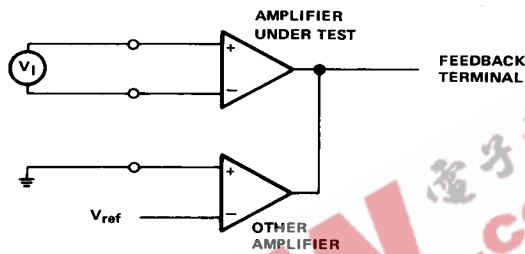

FIGURE 2. AMPLIFIER CHARACTERISTICS

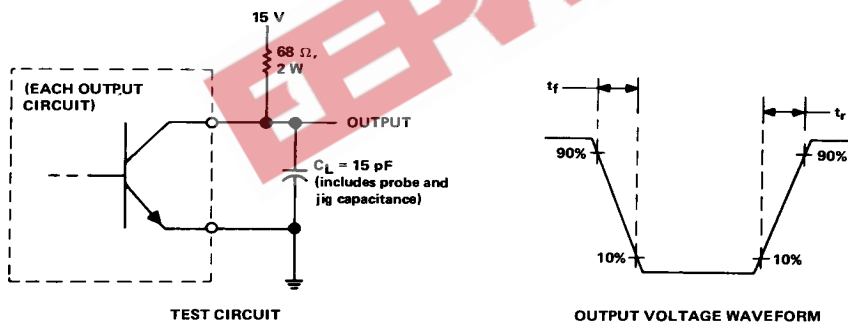

FIGURE 3. COMMON-EMITTER CONFIGURATION

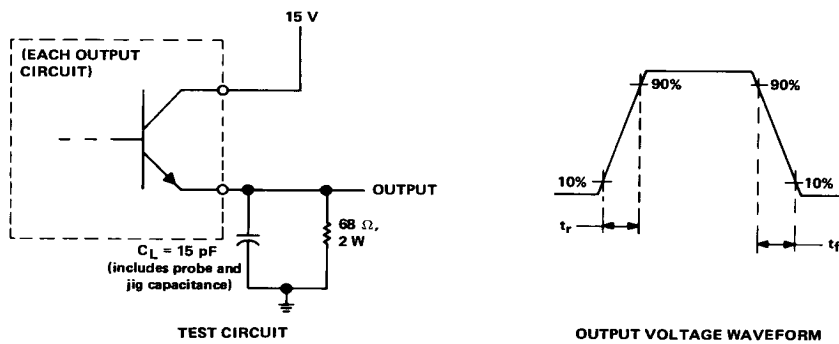

FIGURE 4. EMITTER-FOLLOWER CONFIGURATION

2  
Data Sheets

**TL493, TL494, TL495**  
**PULSE-WIDTH-MODULATION CONTROL CIRCUITS**

**TYPICAL CHARACTERISTICS**

OSCILLATOR FREQUENCY AND  
 FREQUENCY VARIATION<sup>†</sup> vs  
 TIMING RESISTANCE

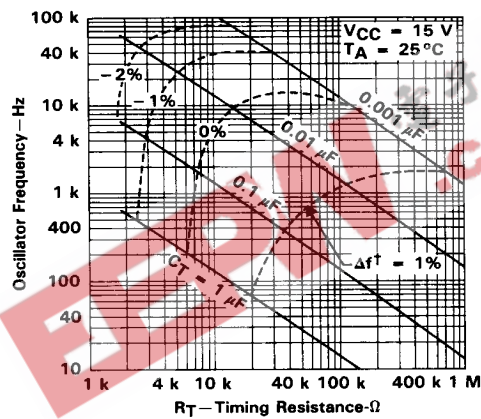

FIGURE 5

AMPLIFIER VOLTAGE AMPLIFICATION  
 vs  
 FREQUENCY

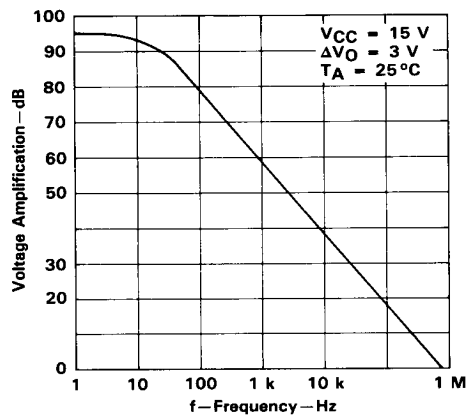

FIGURE 6

<sup>†</sup>Frequency variation (Δf) is the change in oscillator frequency that occurs over the full temperature range.