

TL5001, TL5001A PULSE-WIDTH-MODULATION CONTROL CIRCUITS

SLVS084E – APRIL 1994 – REVISED OCTOBER 1999

- Complete PWM Power Control
- 3.6-V to 40-V Operation
- Internal Undervoltage-Lockout Circuit
- Internal Short-Circuit Protection
- Oscillator Frequency . . . 20 kHz to 500 kHz
- Variable Dead Time Provides Control Over Total Range
- $\pm 3\%$ Tolerance on Reference Voltage (TL5001A)
- Available in Q-Temp Automotive HighRel Automotive Applications Configuration Control / Print Support Qualification to Automotive Standards

description

The TL5001 and TL5001A incorporate on a single monolithic chip all the functions required for a pulse-width-modulation (PWM) control circuit. Designed primarily for power-supply control, the TL5001/A contains an error amplifier, a regulator, an oscillator, a PWM comparator with a dead-time-control input, undervoltage lockout (UVLO), short-circuit protection (SCP), and an open-collector output transistor. The TL5001A has a typical reference voltage tolerance of $\pm 3\%$ compared to $\pm 5\%$ for the TL5001.

The error-amplifier common-mode voltage ranges from 0 V to 1.5 V. The noninverting input of the error amplifier is connected to a 1-V reference. Dead-time control (DTC) can be set to provide 0% to 100% dead time by connecting an external resistor between DTC and GND. The oscillator frequency is set by terminating RT with an external resistor to GND. During low V_{CC} conditions, the UVLO circuit turns the output off until V_{CC} recovers to its normal operating range.

The TL5001C and TL5001AC are characterized for operation from -20°C to 85°C . The TL5001I and TL5001AI are characterized for operation from -40°C to 85°C . The TL5001Q and TL5001AQ are characterized for operation from -40°C to 125°C . The TL5001M and TL5001AM are characterized for operation from -55°C to 125°C .

AVAILABLE OPTIONS

T_A	PACKAGED DEVICES			
	SMALL OUTLINE (D)	PLASTIC DIP (P)	CERAMIC DIP (JG)	CHIP CARRIER (FK)
-20°C to 85°C	TL5001CD	TL5001CP	—	—
	TL5001ACD	TL5001ACP	—	—
-40°C to 85°C	TL5001ID	TL5001IP	—	—
	TL5001AID	TL5001AIP	—	—
-40°C to 125°C	TL5001QD	—	—	—
	TL5001AQD	—	—	—
-55°C to 125°C	—	—	TL5001MJG	TL5001MFK
	—	—	TL5001AMJG	TL5001AMFK

The D package is available taped and reeled. Add the suffix R to the device type (e.g., TL5001CDR).

Please be aware that an important notice concerning availability, standard warranty, and use in critical applications of Texas Instruments semiconductor products and disclaimers thereto appears at the end of this data sheet.



PRODUCTION DATA information is current as of publication date. Products conform to specifications per the terms of Texas Instruments standard warranty. Production processing does not necessarily include testing of all parameters.

**TEXAS
INSTRUMENTS**

POST OFFICE BOX 655303 • DALLAS, TEXAS 75265

Copyright © 1999, Texas Instruments Incorporated

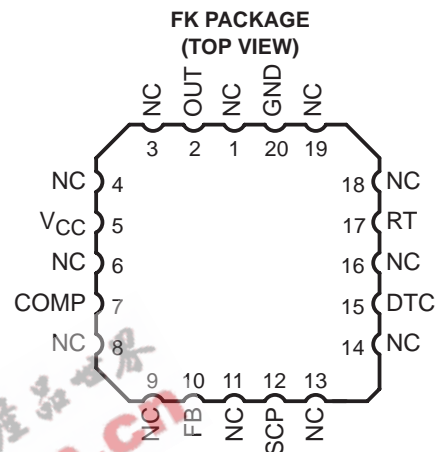
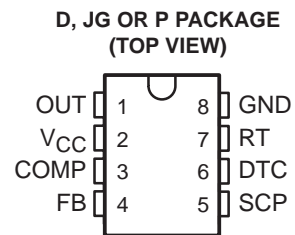

TL5001, TL5001A PULSE-WIDTH-MODULATION CONTROL CIRCUITS

SLVS084E – APRIL 1994 – REVISED OCTOBER 1999

schematic for typical application

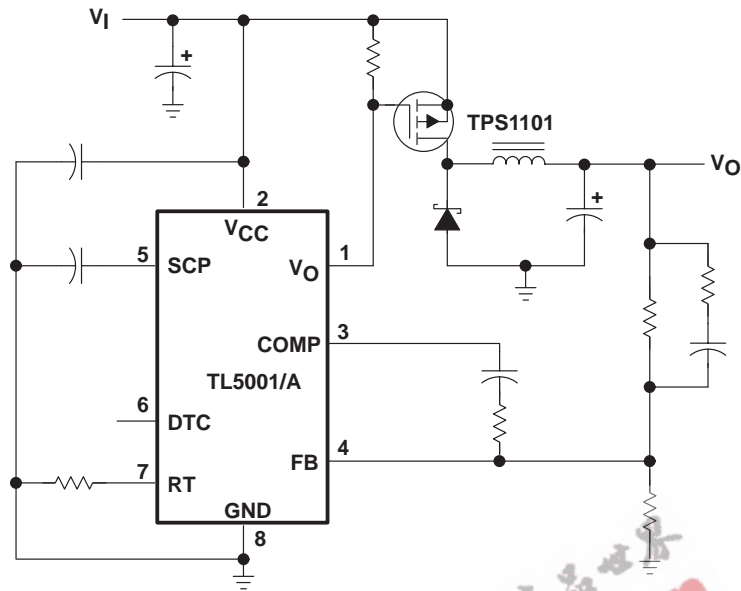

functional block diagram

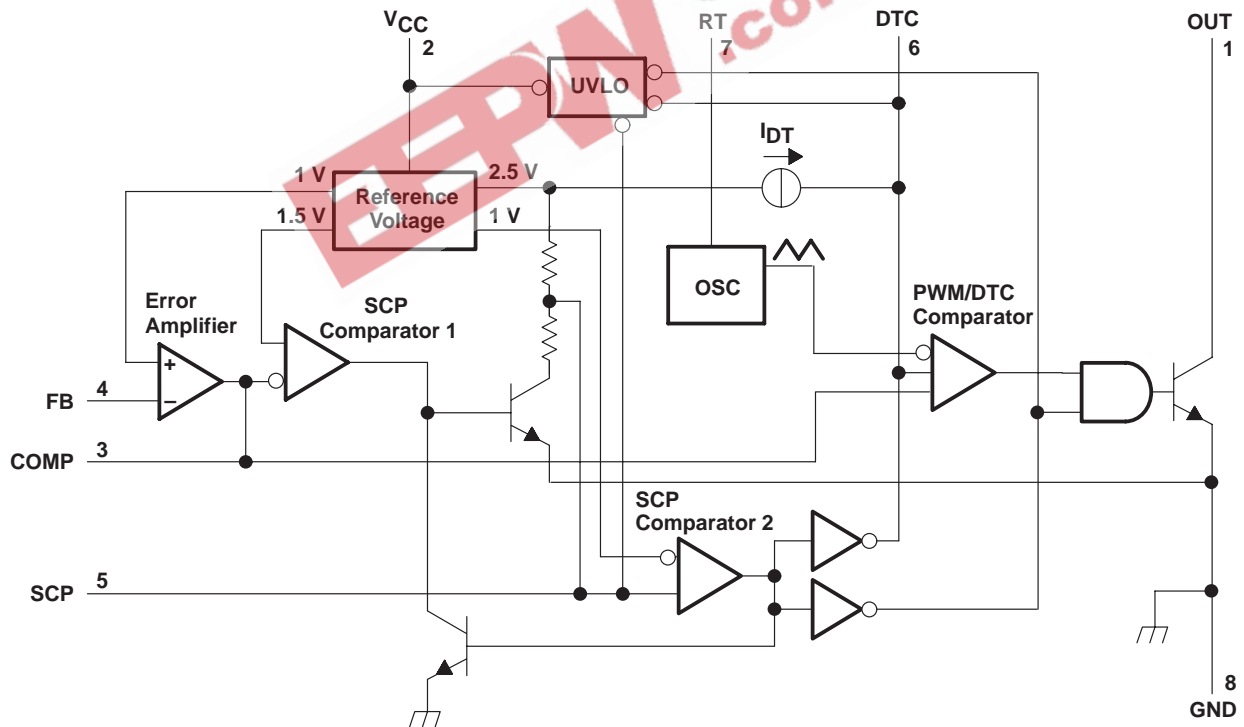

detailed description

voltage reference

A 2.5-V regulator operating from V_{CC} is used to power the internal circuitry of the TL5001 and TL5001A and as a reference for the error amplifier and SCP circuits. A resistive divider provides a 1-V reference for the error amplifier noninverting input which typically is within 2% of nominal over the operating temperature range.

error amplifier

The error amplifier compares a sample of the dc-to-dc converter output voltage to the 1-V reference and generates an error signal for the PWM comparator. The dc-to-dc converter output voltage is set by selecting the error-amplifier gain (see Figure 1), using the following expression:

$$V_O = (1 + R1/R2) (1 \text{ V})$$

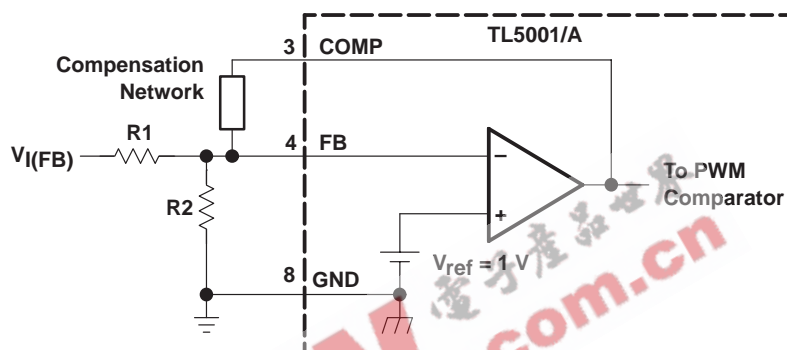

Figure 1. Error-Amplifier Gain Setting

The error-amplifier output is brought out as COMP for use in compensating the dc-to-dc converter control loop for stability. Because the amplifier can only source 45 μ A, the total dc load resistance should be 100 k Ω or more.

oscillator/PWM

The oscillator frequency (f_{osc}) can be set between 20 kHz and 500 kHz by connecting a resistor between RT and GND. Acceptable resistor values range from 15 k Ω to 250 k Ω . The oscillator frequency can be determined by using the graph shown in Figure 5.

The oscillator output is a triangular wave with a minimum value of approximately 0.7 V and a maximum value of approximately 1.3 V. The PWM comparator compares the error-amplifier output voltage and the DTC input voltage to the triangular wave and turns the output transistor off whenever the triangular wave is greater than the lesser of the two inputs.

dead-time control (DTC)

DTC provides a means of limiting the output-switch duty cycle to a value less than 100%, which is critical for boost and flyback converters. A current source generates a reference current (I_{DT}) at DTC that is nominally equal to the current at the oscillator timing terminal, RT. Connecting a resistor between DTC and GND generates a dead-time reference voltage (V_{DT}), which the PWM/DTC comparator compares to the oscillator triangle wave as described in the previous section. Nominally, the maximum duty cycle is 0% when V_{DT} is 0.7 V or less and 100% when V_{DT} is 1.3 V or greater. Because the triangle wave amplitude is a function of frequency and the source impedance of RT is relatively high (1250 Ω), choosing R_{DT} for a specific maximum duty cycle, D, is accomplished using the following equation and the voltage limits for the frequency in question as found in Figure 11 ($V_{osc,max}$ and $V_{osc,min}$ are the maximum and minimum oscillator levels):

TL5001, TL5001A

PULSE-WIDTH-MODULATION CONTROL CIRCUITS

SLVS084E – APRIL 1994 – REVISED OCTOBER 1999

dead-time control (DTC) (continued)

$$R_{DT} = (R_t + 1250) [D(V_{osc\max} - V_{osc\min}) + V_{osc\min}]$$

Where

R_{DT} and R_t are in ohms, D in decimal

Soft start can be implemented by paralleling the DTC resistor with a capacitor (C_{DT}) as shown in Figure 2. During soft start, the voltage at DTC is derived by the following equation:

$$V_{DT} \approx I_{DT}R_{DT} \left(1 - e^{-t/R_{DT}C_{DT}} \right)$$

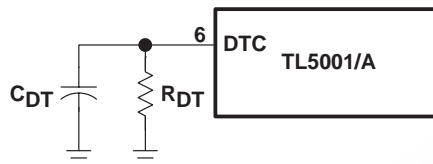

Figure 2. Soft-Start Circuit

If the dc-to-dc converter must be in regulation within a specified period of time, the time constant, $R_{DT}C_{DT}$, should be $t_0/3$ to $t_0/5$. The TL5001/A remains off until $V_{DT} \approx 0.7$ V, the minimum ramp value. C_{DT} is discharged every time UVLO or SCP becomes active.

undervoltage-lockout (UVLO) protection

The undervoltage-lockout circuit turns the output transistor off and resets the SCP latch whenever the supply voltage drops too low (approximately 3 V at 25°C) for proper operation. A hysteresis voltage of 200 mV eliminates false triggering on noise and chattering.

short-circuit protection (SCP)

The TL5001/A includes short-circuit protection (see Figure 3), which turns the power switch off to prevent damage when the converter output is shorted. When activated, the SCP prevents the switch from being turned on until the internal latching circuit is reset. The circuit is reset by reducing the input voltage until UVLO becomes active or until the SCP terminal is pulled to ground externally.

When a short circuit occurs, the error-amplifier output at COMP rises to increase the power-switch duty cycle in an attempt to maintain the output voltage. SCP comparator 1 starts an RC timing circuit when COMP exceeds 1.5 V. If the short is removed and the error-amplifier output drops below 1.5 V before time out, normal converter operation continues. If the fault is still present at the end of the time-out period, the timer sets the latching circuit and turns off the TL5001/A output transistor.

short-circuit protection (SCP) (continued)

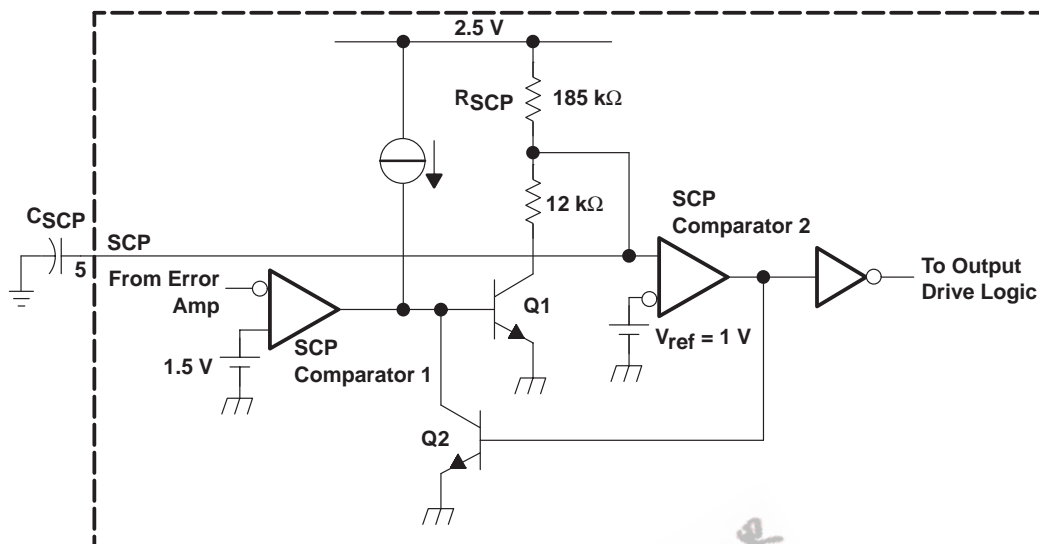

Figure 3. SCP Circuit

The timer operates by charging an external capacitor (C_{SCP}), connected between the SCP terminal and ground, towards 2.5 V through a 185-k Ω resistor (R_{SCP}). The circuit begins charging from an initial voltage of approximately 185 mV and times out when the capacitor voltage reaches 1 V. The output of SCP comparator 2 then goes high, turns on Q2, and latches the timer circuit. The expression for setting the SCP time period is derived from the following equation:

$$V_{SCP} = (2.5 - 0.185) \left(1 - e^{-t/\tau} \right) + 0.185$$

Where

$$\tau = R_{SCP} C_{SCP}$$

The end of the time-out period, t_{SCP} , occurs when $V_{SCP} = 1$ V. Solving for C_{SCP} yields:

$$C_{SCP} = 12.46 \times t_{SCP}$$

Where

t is in seconds, C in μ F.

t_{SCP} must be much longer (generally 10 to 15 times) than the converter start-up period or the converter will not start.

output transistor

The output of the TL5001/A is an open-collector transistor with a maximum collector current rating of 21 mA and a voltage rating of 51 V. The output is turned on under the following conditions: the oscillator triangle wave is lower than both the DTC voltage and the error-amplifier output voltage, the UVLO circuit is inactive, and the short-circuit protection circuit is inactive.

TL5001, TL5001A

PULSE-WIDTH-MODULATION CONTROL CIRCUITS

SLVS084E – APRIL 1994 – REVISED OCTOBER 1999

absolute maximum ratings over operating free-air temperature range (unless otherwise noted)†

Supply voltage, V_{CC} (see Note 1)	41 V
Amplifier input voltage, $V_{I(FB)}$	20 V
Output voltage, $V_{O, OUT}$	51 V
Output current, $I_{O, OUT}$	21 mA
Output peak current, $I_{O(peak), OUT}$	100 mA
Continuous total power dissipation	See Dissipation Rating Table
Operating ambient temperature range, T_A :	
TL5001C, TL5001AC	–20°C to 85°C
TL5001I, TL5001AI	–40°C to 85°C
TL5001Q, TL5001AQ	–40°C to 125°C
TL5001M, TL5001AM	–55°C to 125°C
Storage temperature range, T_{stg}	–65°C to 150°C
Lead temperature 1,6 mm (1/16 inch) from case for 10 seconds	260°C

† Stresses beyond those listed under “absolute maximum ratings” may cause permanent damage to the device. These are stress ratings only, and functional operation of the device at these or any other conditions beyond those indicated under “recommended operating conditions” is not implied. Exposure to absolute-maximum-rated conditions for extended periods may affect device reliability.

NOTE 1: All voltage values are with respect to network ground terminal.

DISSIPATION RATING TABLE

PACKAGE	$T_A \leq 25^\circ\text{C}$ POWER RATING	DERATING FACTOR ABOVE $T_A = 25^\circ\text{C}$	$T_A = 70^\circ\text{C}$ POWER RATING	$T_A = 85^\circ\text{C}$ POWER RATING	$T_A = 125^\circ\text{C}$ POWER RATING
D	725 mW	5.8 mW/°C	464 mW	377 mW	145 mW
FK	1375 mW	11.0 mW/°C	880 mW	715 mW	275 mW
JG	1050 mW	8.4 mW/°C	672 mW	546 mW	210 mW
P	1000 mW	8.0 mW/°C	640 mW	520 mW	200 mW

recommended operating conditions

	MIN	MAX	UNIT
Supply voltage, V_{CC}	3.6	40	V
Amplifier input voltage, $V_{I(FB)}$	0	1.5	V
Output voltage, $V_{O, OUT}$		50	V
Output current, $I_{O, OUT}$		20	mA
COMP source current		45	μA
COMP dc load resistance	100		k Ω
Oscillator timing resistor, R_t	15	250	k Ω
Oscillator frequency, f_{osc}	20	500	kHz
Operating ambient temperature, T_A	TL5001C, TL5001AC	–20	85
	TL5001I, TL5001AI	–40	85
	TL5001Q, TL5001AQ	–40	125
	TL5001M, TL5001AM	–55	125

TL5001, TL5001A

PULSE-WIDTH-MODULATION CONTROL CIRCUITS

SLVS084E – APRIL 1994 – REVISED OCTOBER 1999

electrical characteristics over recommended operating free-air temperature range, $V_{CC} = 6\text{ V}$, $f_{osc} = 100\text{ kHz}$ (unless otherwise noted)

reference

PARAMETER	TEST CONDITIONS	TL5001C, TL5001I			TL5001AC, TL5001AI			UNIT
		MIN	TYP†	MAX	MIN	TYP†	MAX	
Output voltage	COMP connected to FB	0.95	1	1.05	0.97	1	1.03	V
Input regulation	$V_{CC} = 3.6\text{ V to }40\text{ V}$		2	12.5		2	12.5	mV
Output voltage change with temperature	$T_A = -20^\circ\text{C to }25^\circ\text{C}$ (C suffix)	-10	-1	10	-10	-1	10	mV/V
	$T_A = -40^\circ\text{C to }25^\circ\text{C}$ (I suffix)	-10	-1	10	-10	-1	10	
	$T_A = 25^\circ\text{C to }85^\circ\text{C}$	-10	-2	10	-10	-2	10	

† All typical values are at $T_A = 25^\circ\text{C}$.

undervoltage lockout

PARAMETER	TEST CONDITIONS	TL5001C, TL5001I			TL5001AC, TL5001AI			UNIT
		MIN	TYP†	MAX	MIN	TYP†	MAX	
Upper threshold voltage	$T_A = 25^\circ\text{C}$		3			3		V
Lower threshold voltage	$T_A = 25^\circ\text{C}$		2.8			2.8		V
Hysteresis	$T_A = 25^\circ\text{C}$	100	200		100	200		mV
Reset threshold voltage	$T_A = 25^\circ\text{C}$	2.1	2.55		2.1	2.55		V

† All typical values are at $T_A = 25^\circ\text{C}$.

short-circuit protection

PARAMETER	TEST CONDITIONS	TL5001C, TL5001I			TL5001AC, TL5001AI			UNIT
		MIN	TYP†	MAX	MIN	TYP†	MAX	
SCP threshold voltage	$T_A = 25^\circ\text{C}$	0.95	1.00	1.05	0.97	1.00	1.03	V
SCP voltage, latched	No pullup	140	185	230	140	185	230	mV
SCP voltage, UVLO standby	No pullup		60	120		60	120	mV
Input source current	$T_A = 25^\circ\text{C}$	-10	-15	-20	-10	-15	-20	μA
SCP comparator 1 threshold voltage			1.5			1.5		V

† All typical values are at $T_A = 25^\circ\text{C}$.

oscillator

PARAMETER	TEST CONDITIONS	TL5001C, TL5001I			TL5001AC, TL5001AI			UNIT
		MIN	TYP†	MAX	MIN	TYP†	MAX	
Frequency	$R_t = 100\text{ k}\Omega$		100			100		kHz
Standard deviation of frequency			15			15		kHz
Frequency change with voltage	$V_{CC} = 3.6\text{ V to }40\text{ V}$		1			1		kHz
Frequency change with temperature	$T_A = -40^\circ\text{C to }25^\circ\text{C}$	-4	-0.4	4	-4	-0.4	4	kHz
	$T_A = -20^\circ\text{C to }25^\circ\text{C}$	-4	-0.4	4	-4	-0.4	4	kHz
	$T_A = 25^\circ\text{C to }85^\circ\text{C}$	-4	-0.2	4	-4	-0.2	4	kHz
Voltage at RT			1			1		V

† All typical values are at $T_A = 25^\circ\text{C}$.

TL5001, TL5001A

PULSE-WIDTH-MODULATION CONTROL CIRCUITS

SLVS084E – APRIL 1994 – REVISED OCTOBER 1999

electrical characteristics over recommended operating free-air temperature range, $V_{CC} = 6\text{ V}$, $f_{osc} = 100\text{ kHz}$ (unless otherwise noted) (continued)

dead-time control

PARAMETER		TEST CONDITIONS	TL5001C, TL5001I			TL5001AC, TL5001AI			UNIT
			MIN	TYP†	MAX	MIN	TYP†	MAX	
Output (source) current	TL5001C	$V_{(DT)} = 1.5\text{ V}$	$0.9 \times I_{RT}^{\ddagger}$		$1.1 \times I_{RT}$	$0.9 \times I_{RT}^{\ddagger}$		$1.1 \times I_{RT}$	μA
	TL5001I	$V_{(DT)} = 1.5\text{ V}$	$0.9 \times I_{RT}^{\ddagger}$		$1.2 \times I_{RT}$	$0.9 \times I_{RT}^{\ddagger}$		$1.2 \times I_{RT}$	
Input threshold voltage		Duty cycle = 0%	0.5	0.7		0.5	0.7		V
		Duty cycle = 100%		1.3	1.5		1.3	1.5	

† All typical values are at $T_A = 25^\circ\text{C}$.

‡ Output source current at RT

error amplifier

PARAMETER		TEST CONDITIONS	TL5001C, TL5001I			TL5001AC, TL5001AI			UNIT
			MIN	TYP†	MAX	MIN	TYP†	MAX	
Input voltage		$V_{CC} = 3.6\text{ V to }40\text{ V}$	0		1.5	0		1.5	V
Input bias current				-160	-500		-160	-500	nA
Output voltage swing	Positive		1.5	2.3		1.5	2.3		V
	Negative			0.3	0.4		0.3	0.4	V
Open-loop voltage amplification				80			80		dB
Unity-gain bandwidth				1.5			1.5		MHz
Output (sink) current		$V_{I(FB)} = 1.2\text{ V}$, $COMP = 1\text{ V}$		100	600		100	600	μA
Output (source) current		$V_{I(FB)} = 0.8\text{ V}$, $COMP = 1\text{ V}$		-45	-70		-45	-70	μA

† All typical values are at $T_A = 25^\circ\text{C}$.

output

PARAMETER		TEST CONDITIONS	TL5001C, TL5001I			TL5001AC, TL5001AI			UNIT
			MIN	TYP†	MAX	MIN	TYP†	MAX	
Output saturation voltage		$I_O = 10\text{ mA}$		1.5	2		1.5	2	V
Off-state current		$V_O = 50\text{ V}$, $V_{CC} = 0$			10			10	μA
		$V_O = 50\text{ V}$			10			10	
Short-circuit output current		$V_O = 6\text{ V}$		40			40		mA

† All typical values are at $T_A = 25^\circ\text{C}$.

total device

PARAMETER		TEST CONDITIONS	TL5001C, TL5001I			TL5001AC, TL5001AI			UNIT
			MIN	TYP†	MAX	MIN	TYP†	MAX	
Standby supply current	Off state			1	1.5		1	1.5	mA
Average supply current		$R_t = 100\text{ k}\Omega$		1.4	2.1		1.4	2.1	mA

† All typical values are at $T_A = 25^\circ\text{C}$.

TL5001, TL5001A PULSE-WIDTH-MODULATION CONTROL CIRCUITS

SLVS084E – APRIL 1994 – REVISED OCTOBER 1999

electrical characteristics over recommended operating free-air temperature range, $V_{CC} = 6\text{ V}$, $f_{osc} = 100\text{ kHz}$ (unless otherwise noted)

reference

PARAMETER	TEST CONDITIONS		TL5001Q, TL5001M			TL5001AQ, TL5001AM			UNIT
			MIN	TYP†	MAX	MIN	TYP†	MAX	
Output voltage	$T_A = \text{MIN}, 25^\circ\text{C}$	COMP connected to FB	0.95	1.00	1.05	0.97	1.00	1.03	V
	$T_A = \text{MAX}$		0.93	0.98	1.07	0.94	0.98	1.06	
Input regulation	$T_A = \text{MIN to MAX}$	$V_{CC} = 3.6\text{ V to }40\text{ V}$	2		12.5	2		12.5	mV
Output voltage change with temperature	$T_A = \text{MIN to MAX}$		*-6	2	*6	*-6	2	*6	%

† All typical values are at $T_A = 25^\circ\text{C}$.

*Not production tested.

undervoltage lockout

PARAMETER	TEST CONDITIONS		TL5001Q, TL5001M			TL5001AQ, TL5001AM			UNIT
			MIN	TYP†	MAX	MIN	TYP†	MAX	
Upper threshold voltage	$T_A = \text{MIN}, 25^\circ\text{C}$		3.00			3.00			V
	$T_A = \text{MAX}$		2.55			2.55			
Lower threshold voltage	$T_A = \text{MIN}, 25^\circ\text{C}$		2.8			2.8			V
	$T_A = \text{MAX}$		2.0			2.0			
Hysteresis	$T_A = \text{MIN to MAX}$		100	200		100	200		mV
Reset threshold voltage	$T_A = \text{MIN}, 25^\circ\text{C}$		2.10	2.55		2.10	2.55		V
	$T_A = \text{MAX}$		0.35	0.63		0.35	0.63		

† All typical values are at $T_A = 25^\circ\text{C}$.

short-circuit protection

PARAMETER	TEST CONDITIONS		TL5001Q, TL5001M			TL5001AQ, TL5001AM			UNIT
			MIN	TYP†	MAX	MIN	TYP†	MAX	
SCP threshold voltage	$T_A = \text{MIN}, 25^\circ\text{C}$		0.95	1.00	1.05	0.97	1.00	1.03	V
	$T_A = \text{MAX}$		0.93	0.98	1.07	0.94	0.98	1.06	
SCP voltage, latched	$T_A = \text{MIN to MAX}$	No pullup	140	185	230	140	185	230	mV
SCP voltage, UVLO standby	$T_A = \text{MIN to MAX}$	No pullup	60		120	60		120	mV
Equivalent timing resistance	$T_A = \text{MIN to MAX}$		185			185			k Ω
SCP comparator 1 threshold voltage	$T_A = \text{MIN to MAX}$		1.5			1.5			V

† All typical values are at $T_A = 25^\circ\text{C}$.

TL5001, TL5001A

PULSE-WIDTH-MODULATION CONTROL CIRCUITS

SLVS084E – APRIL 1994 – REVISED OCTOBER 1999

electrical characteristics over recommended operating free-air temperature range, $V_{CC} = 6\text{ V}$, $f_{osc} = 100\text{ kHz}$ (unless otherwise noted) (continued)

oscillator

PARAMETER	TEST CONDITIONS		TL5001Q, TL5001M			TL5001AQ, TL5001AM			UNIT
			MIN	TYP†	MAX	MIN	TYP†	MAX	
Frequency	$T_A = \text{MIN to MAX}$	$R_t = 100\text{ k}\Omega$	100			100			kHz
Standard deviation of frequency	$T_A = \text{MIN to MAX}$		2			2			kHz
Frequency change with voltage	$T_A = \text{MIN to MAX}$	$V_{CC} = 3.6\text{ V to }40\text{ V}$	1			1			kHz
Frequency change with temperature	$T_A = \text{MIN to MAX}$	Q suffix	*-6	3	*6	*-6	3	*6	kHz
		M suffix	*-9	5	*9	*-9	5	*9	
Voltage at RT	$T_A = \text{MIN to MAX}$		1			1			V

† All typical values are at $T_A = 25^\circ\text{C}$.

*Not production tested.

dead-time control

PARAMETER	TEST CONDITIONS		TL5001Q, TL5001M			TL5001AQ, TL5001AM			UNIT
			MIN	TYP†	MAX	MIN	TYP†	MAX	
Output (source) current	$T_A = \text{MIN to MAX}$	$V_{(DT)} = 1.5\text{ V}$	$0.9 \times I_{RT}^\ddagger$		$1.1 \times I_{RT}^\ddagger$	$0.9 \times I_{RT}^\ddagger$		$1.1 \times I_{RT}^\ddagger$	μA
Input threshold voltage	$T_A = 25^\circ\text{C}$	Duty cycle = 0%	0.5	0.7	0.5	0.7	0.5	0.7	V
		Duty cycle = 100%	1.3	1.5	1.3	1.5	1.3	1.5	
	$T_A = \text{MIN to MAX}$	Duty cycle = 0%	0.4	0.7	0.4	0.7	0.4	0.7	
		Duty cycle = 100%	1.3	1.7	1.3	1.7	1.3	1.7	

† All typical values are at $T_A = 25^\circ\text{C}$.

‡ Output source current at RT

error amplifier

PARAMETER	TEST CONDITIONS		TL5001Q, TL5001M			TL5001AQ, TL5001AM			UNIT
			MIN	TYP†	MAX	MIN	TYP†	MAX	
Input bias current	$T_A = \text{MIN to MAX}$		-160	-500	-160	-500	-160	-500	nA
Output voltage swing	Positive	$T_A = \text{MIN to MAX}$	1.5	2.3	1.5	2.3	1.5	2.3	V
	Negative		0.3	0.4	0.3	0.4	0.3	0.4	V
Open-loop voltage amplification	$T_A = \text{MIN to MAX}$		80			80			dB
Unity-gain bandwidth	$T_A = \text{MIN to MAX}$		1.5			1.5			MHz
Output (sink) current	$T_A = \text{MIN to MAX}$	$V_{I(FB)} = 1.2\text{ V}, \text{ COMP} = 1\text{ V}$	100	600	100	600	100	600	μA
Output (source) current	$T_A = \text{MIN}, 25^\circ\text{C}$	$V_{I(FB)} = 0.8\text{ V}, \text{ COMP} = 1\text{ V}$	-45	-70	-45	-70	-45	-70	μA
	$T_A = \text{MAX}$		-30	-45	-30	-45	-30	-45	

† All typical values are at $T_A = 25^\circ\text{C}$.

TL5001, TL5001A PULSE-WIDTH-MODULATION CONTROL CIRCUITS

SLVS084E – APRIL 1994 – REVISED OCTOBER 1999

electrical characteristics over recommended operating free-air temperature range, $V_{CC} = 6\text{ V}$, $f_{osc} = 100\text{ kHz}$ (unless otherwise noted) (continued)

output

PARAMETER	TEST CONDITIONS		TL5001Q, TL5001M			TL5001AQ, TL5001AM			UNIT
			MIN	TYP†	MAX	MIN	TYP†	MAX	
Output saturation voltage	$T_A = \text{MIN to MAX}$	$I_O = 10\text{ mA}$	1.5		2	1.5		2	V
Off-state current	$T_A = \text{MIN to MAX}$	$V_O = 50\text{ V}, V_{CC} = 0$			10			10	μA
		$V_O = 50\text{ V}$			10			10	
Short-circuit output current	$T_A = \text{MIN to MAX}$	$V_O = 6\text{ V}$			40			40	mA

† All typical values are at $T_A = 25^\circ\text{C}$.

total device

PARAMETER		TEST CONDITIONS		TL5001Q, TL5001M			TL5001AQ, TL5001AM			UNIT
				MIN	TYP†	MAX	MIN	TYP†	MAX	
Standby supply current	Off state	$T_A = \text{MIN to MAX}$			1	1.5		1	1.5	mA
Average supply current		$T_A = \text{MIN to MAX}$	$R_t = 100\text{ k}\Omega$		1.4	2.1		1.4	2.1	mA

† All typical values are at $T_A = 25^\circ\text{C}$.



TL5001, TL5001A PULSE-WIDTH-MODULATION CONTROL CIRCUITS

SLVS084E – APRIL 1994 – REVISED OCTOBER 1999

PARAMETER MEASUREMENT INFORMATION

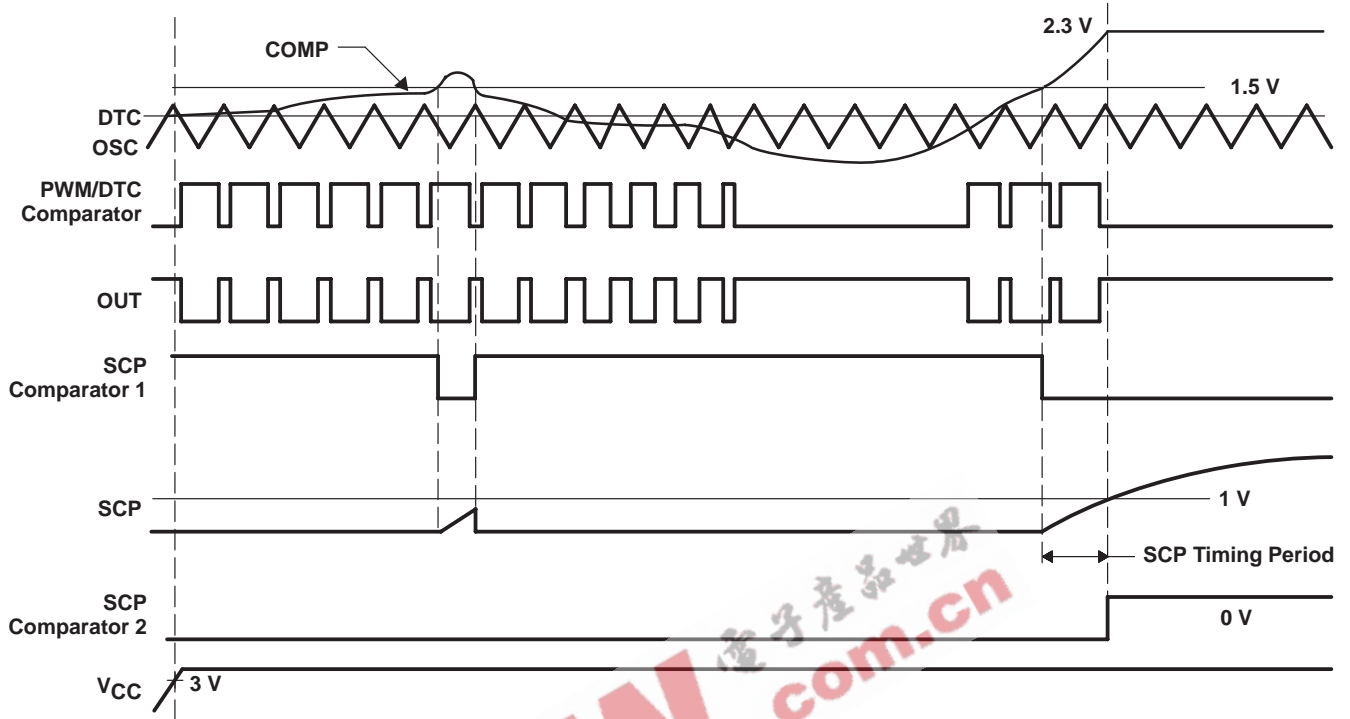

NOTE A: The waveforms show timing characteristics for an intermittent short circuit and a longer short circuit that is sufficient to activate SCP.

Figure 4. PWM Timing Diagram

TYPICAL CHARACTERISTICS

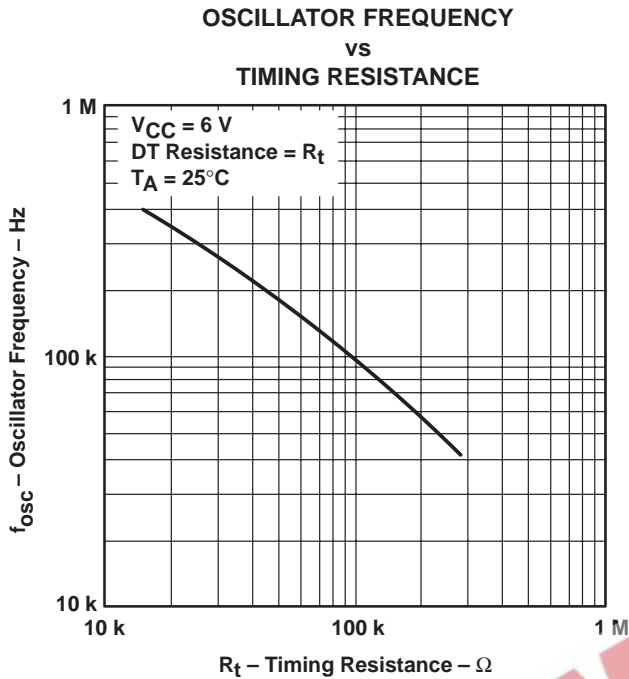

Figure 5

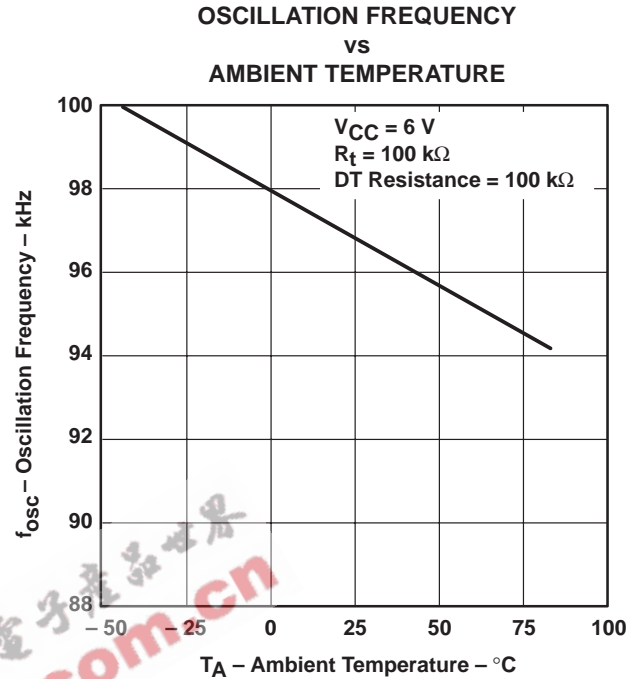

Figure 6

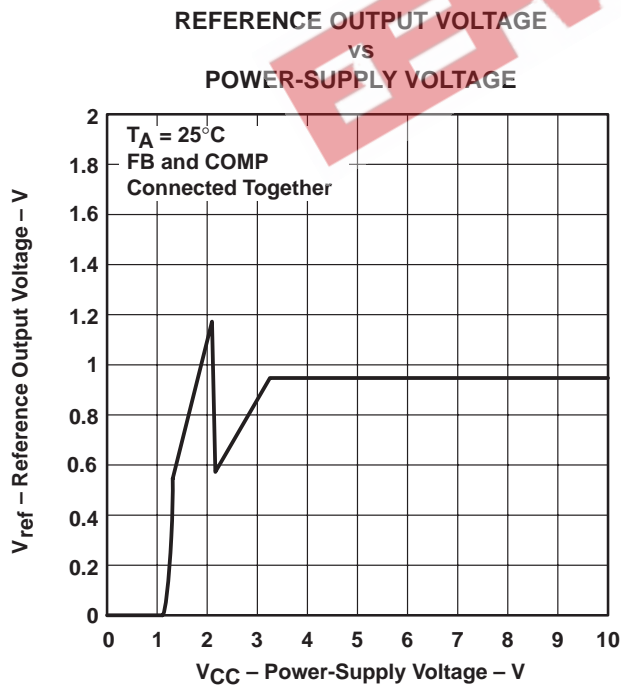

Figure 7

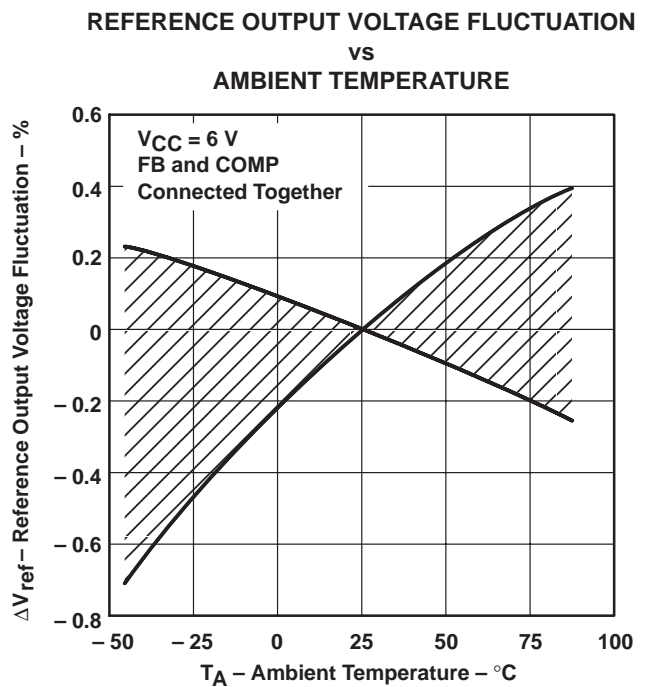
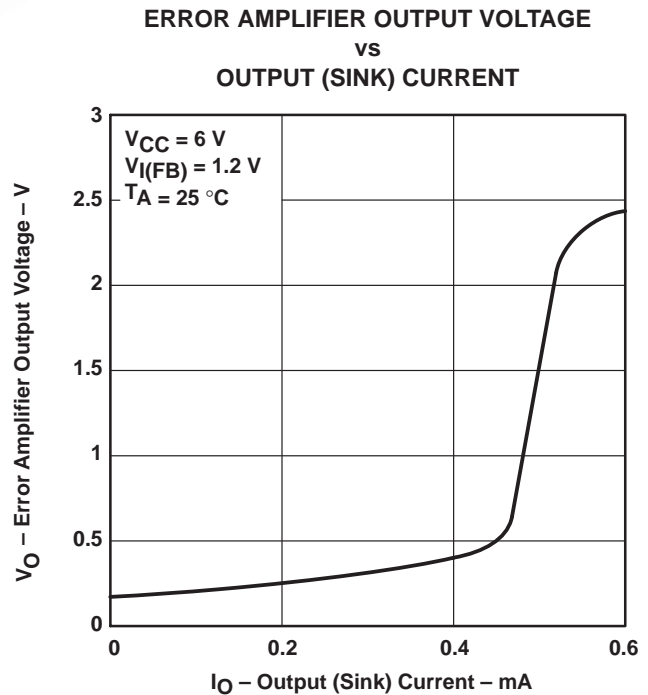
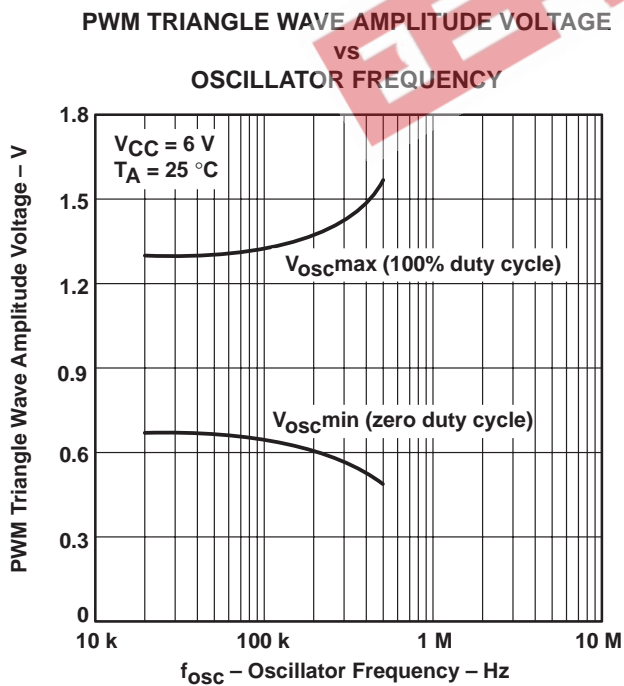
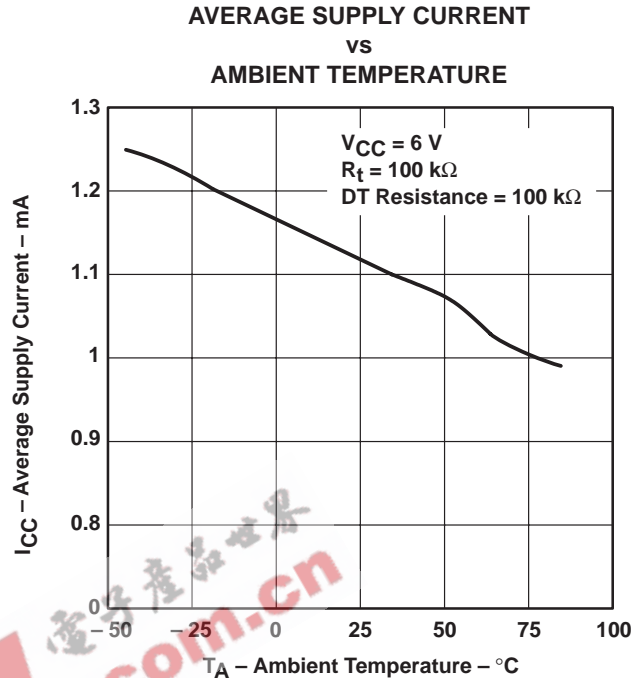
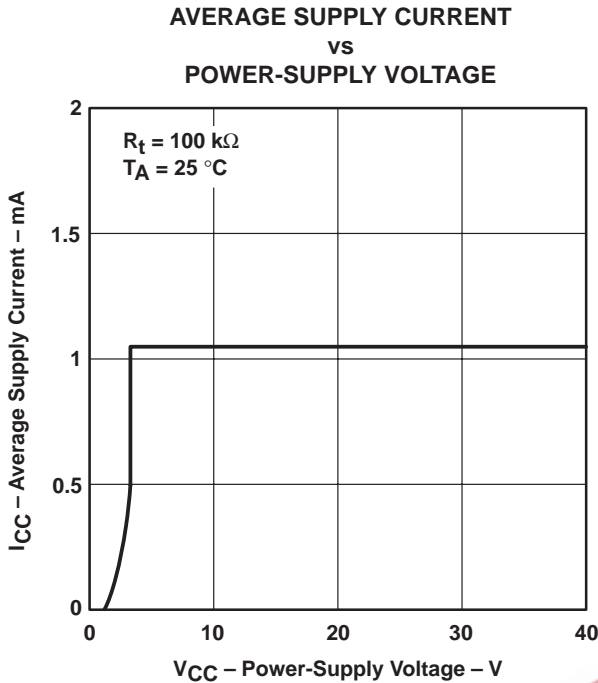

Figure 8

TL5001, TL5001A PULSE-WIDTH-MODULATION CONTROL CIRCUITS

SLVS084E – APRIL 1994 – REVISED OCTOBER 1999

TYPICAL CHARACTERISTICS



TYPICAL CHARACTERISTICS

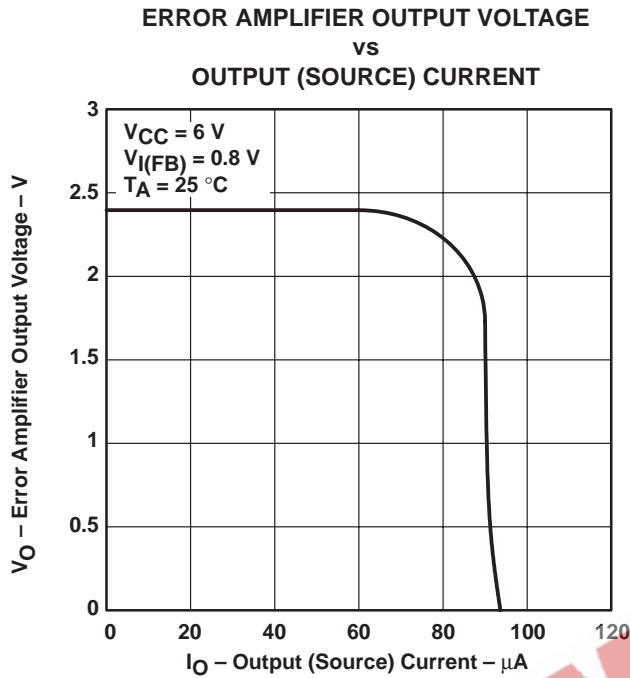

Figure 13

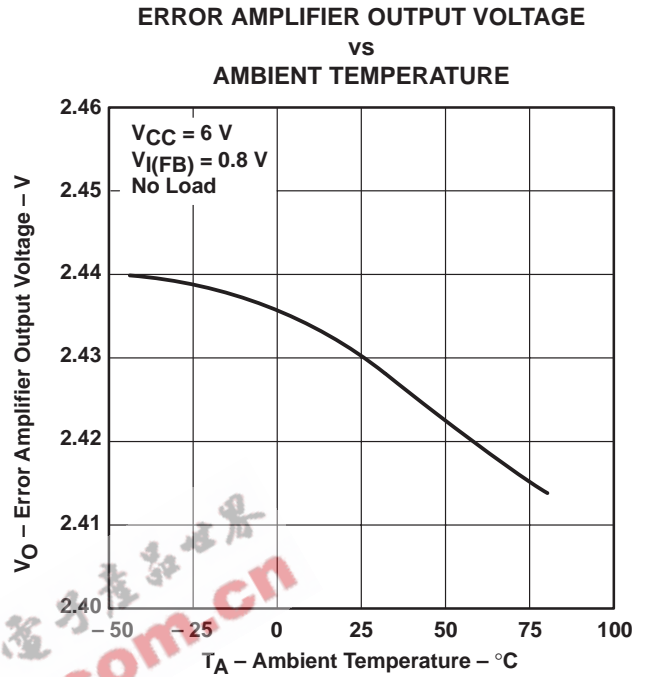

Figure 14

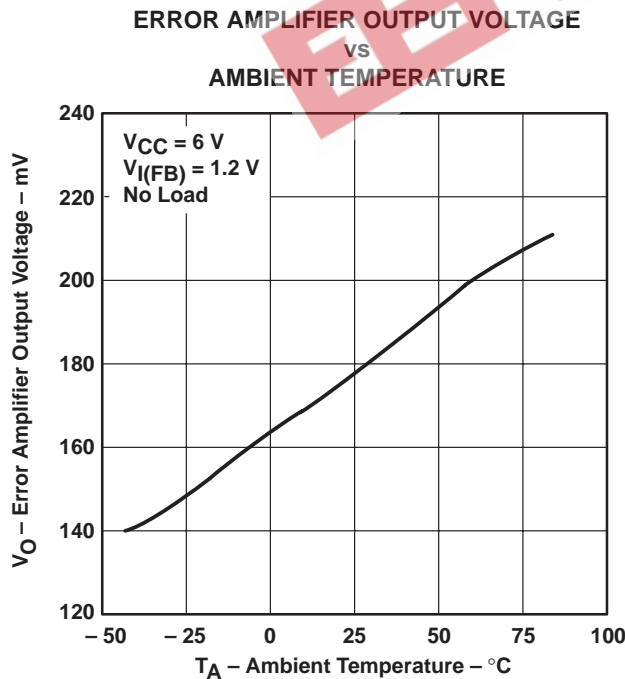

Figure 15

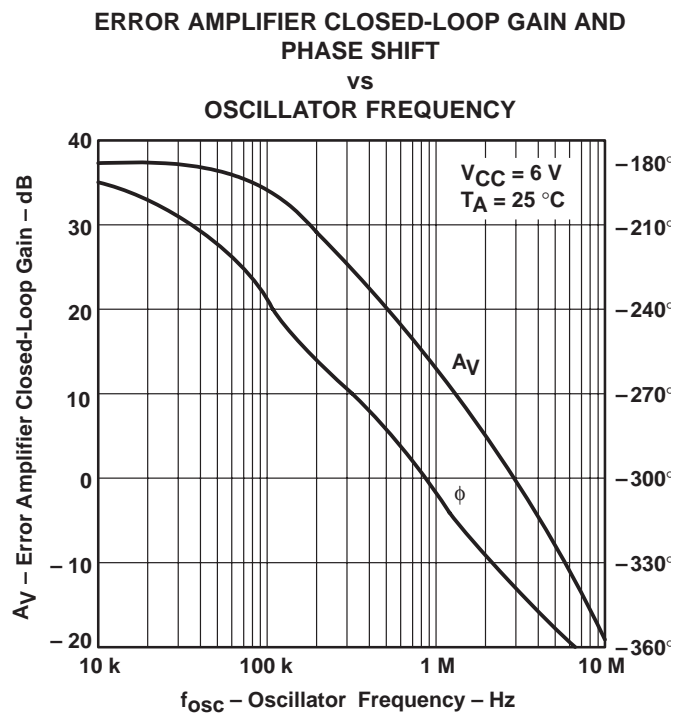

Figure 16

TL5001, TL5001A PULSE-WIDTH-MODULATION CONTROL CIRCUITS

SLVS084E – APRIL 1994 – REVISED OCTOBER 1999

TYPICAL CHARACTERISTICS

OUTPUT DUTY CYCLE
vs
DTC VOLTAGE

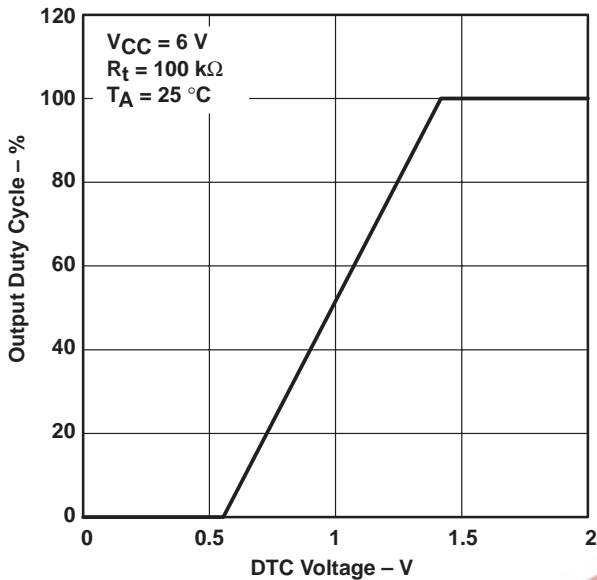

Figure 17

SCP TIME-OUT PERIOD
vs
SCP CAPACITANCE

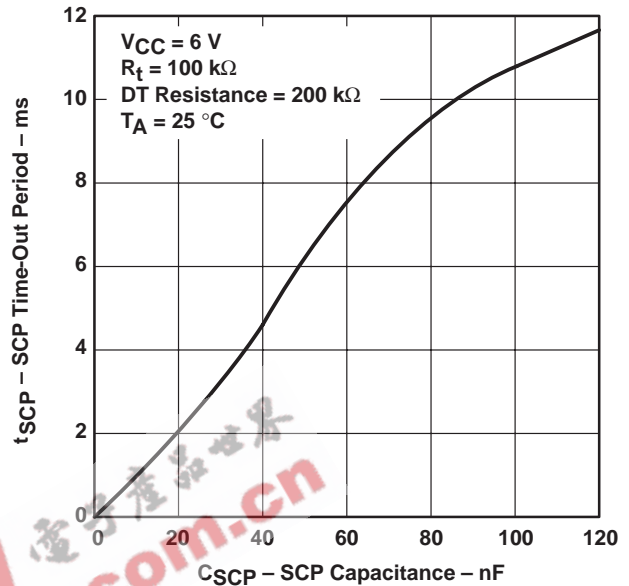

Figure 18

DTC OUTPUT CURRENT
vs
RT OUTPUT CURRENT

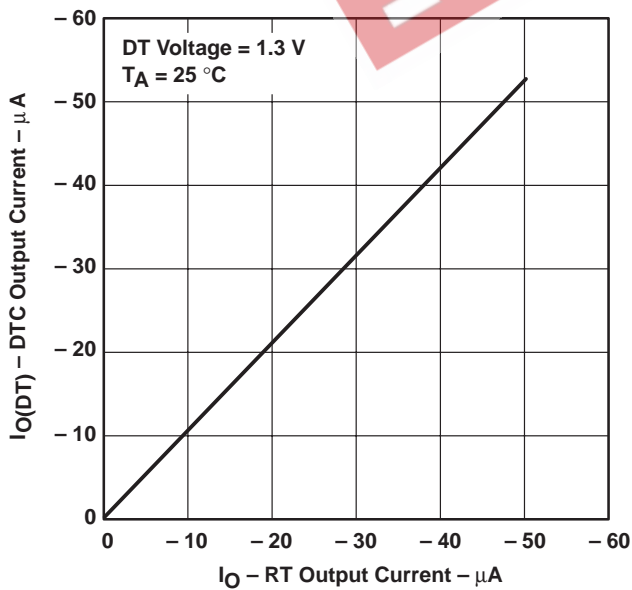

Figure 19

OUTPUT SATURATION VOLTAGE
vs
OUTPUT (SINK) CURRENT

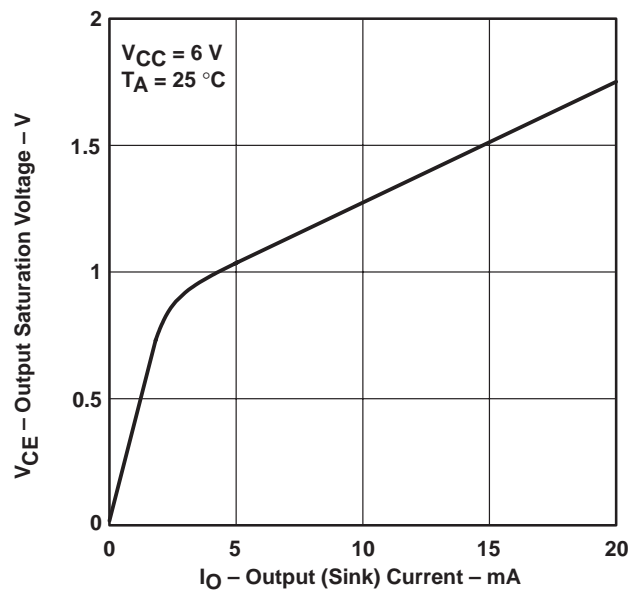
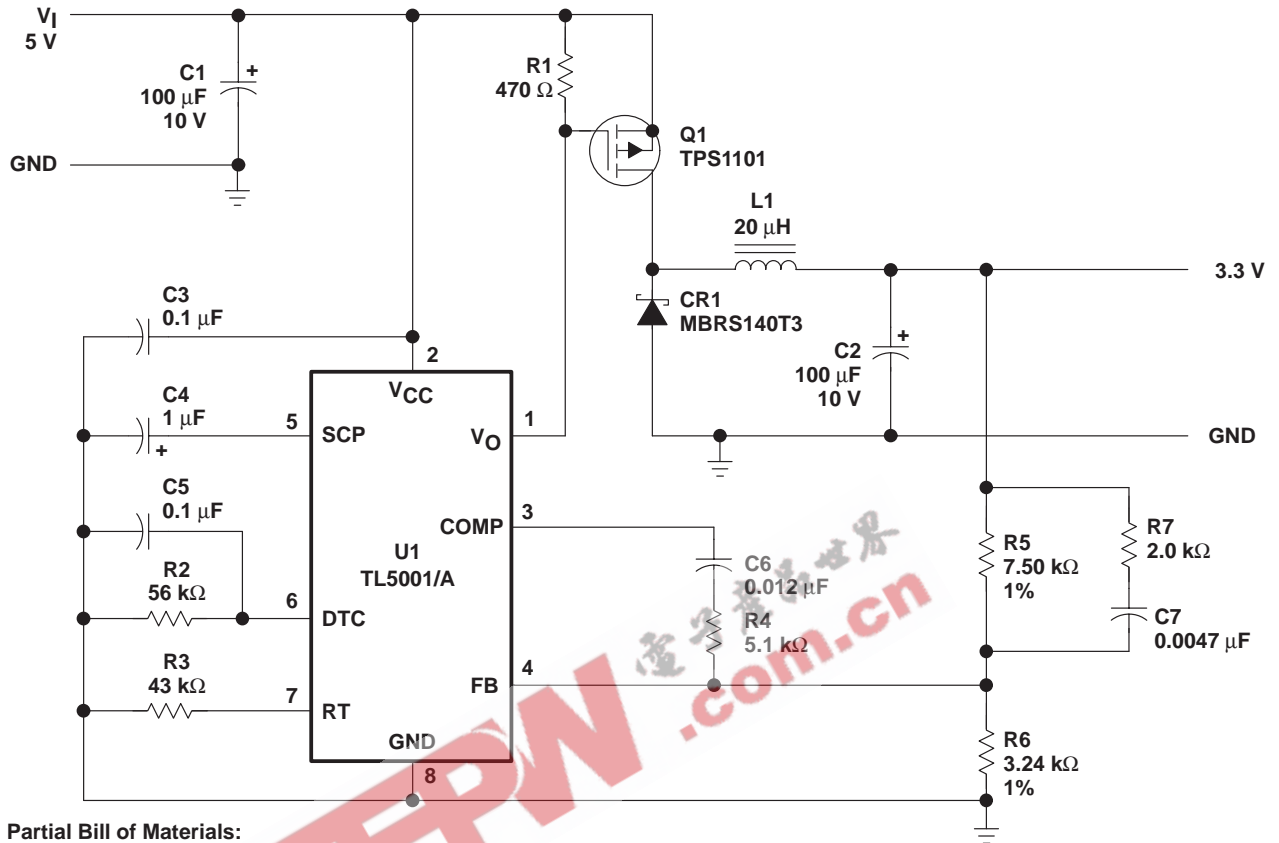

Figure 20

TL5001, TL5001A PULSE-WIDTH-MODULATION CONTROL CIRCUITS

SLVS084E – APRIL 1994 – REVISED OCTOBER 1999

APPLICATION INFORMATION



Partial Bill of Materials:

U1	TL5001/A	Texas Instruments
Q1	TPS1101	Texas Instruments
LI	CTX20-1 or 23 turns of #28 wire on Micrometals No. T50-26B core	Coiltronics
C1	TPSD107M010R0100	AVX
C2	TPSD107M010R0100	AVX
CR1	MBRS140T3	Motorola

- NOTES: A. Frequency = 200 kHz
 B. Duty cycle = 90% max
 C. Soft-start time constant (TC) = 5.6 ms
 D. SCP TC = 70 msA

Figure 21. Step-Down Converter

TL5001, TL5001A PULSE-WIDTH-MODULATION CONTROL CIRCUITS

SLVS084E – APRIL 1994 – REVISED OCTOBER 1999

MECHANICAL DATA

D (R-PDSO-G**)

PLASTIC SMALL-OUTLINE PACKAGE

14 PIN SHOWN

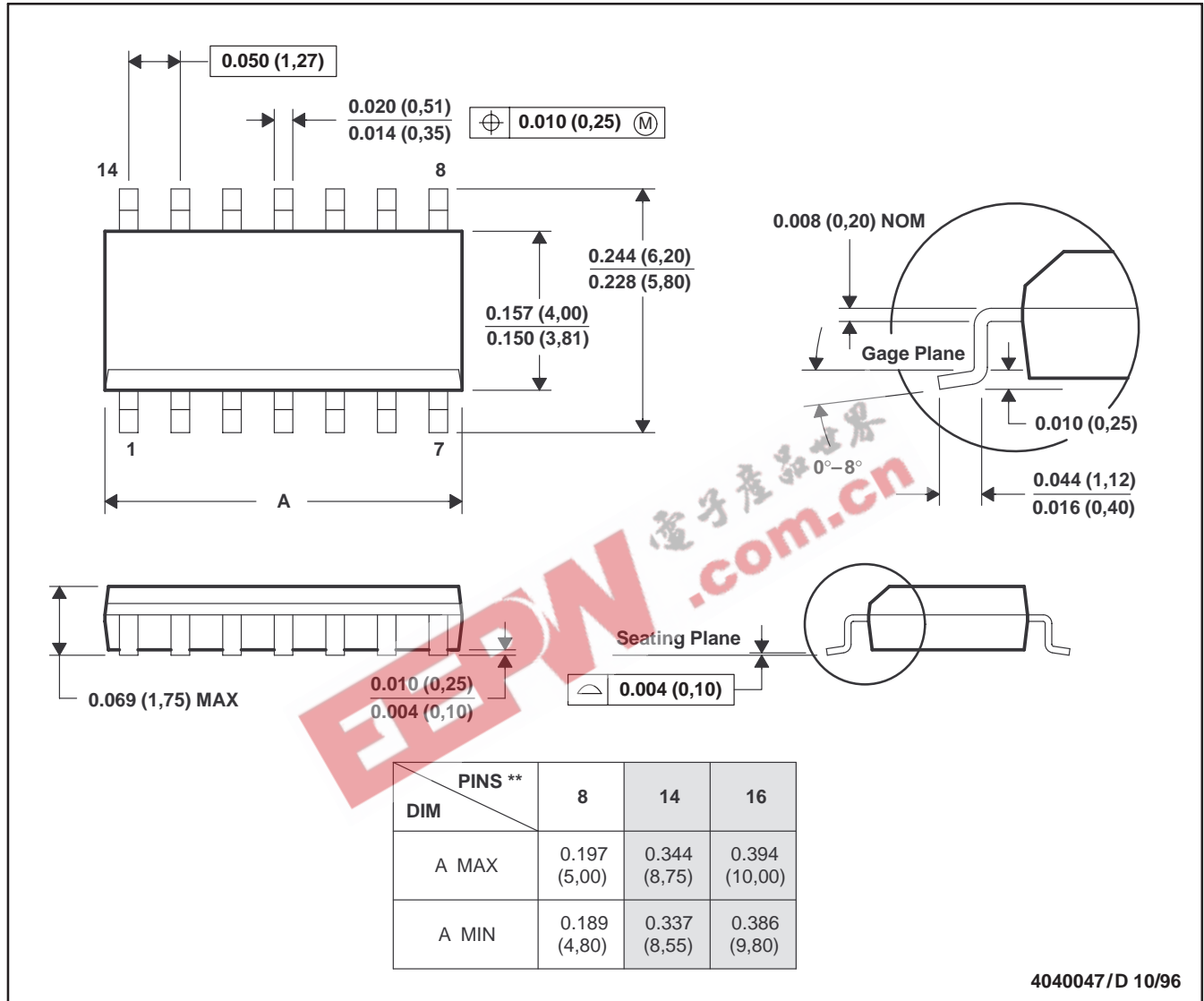

- NOTES: B. All linear dimensions are in inches (millimeters).
 C. This drawing is subject to change without notice.
 D. Body dimensions do not include mold flash or protrusion, not to exceed 0.006 (0,15).
 E. Falls within JEDEC MS-012

TL5001, TL5001A PULSE-WIDTH-MODULATION CONTROL CIRCUITS

SLVS084E – APRIL 1994 – REVISED OCTOBER 1999

MECHANICAL DATA

FK (S-CQCC-N)**

LEADLESS CERAMIC CHIP CARRIER

28 TERMINALS SHOWN

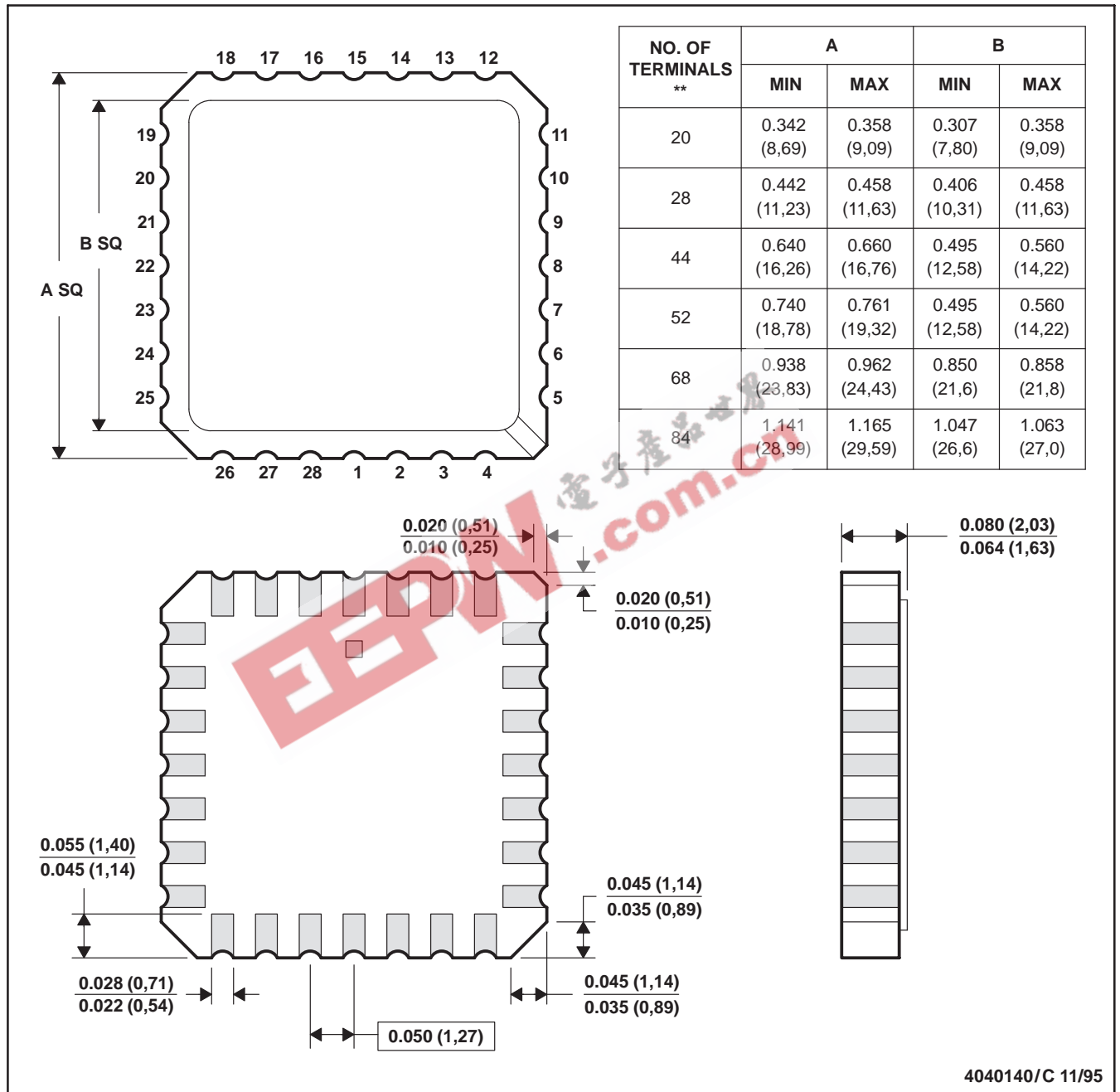

- NOTES: A. All linear dimensions are in inches (millimeters).
 B. This drawing is subject to change without notice.
 C. This package can be hermetically sealed with a metal lid.
 D. The terminals are gold-plated.
 E. Falls within JEDEC MS-004

MECHANICAL DATA

MCER001A – JANUARY 1995 – REVISED JANUARY 1997

MECHANICAL DATA

JG (R-GDIP-T8)

CERAMIC DUAL-IN-LINE

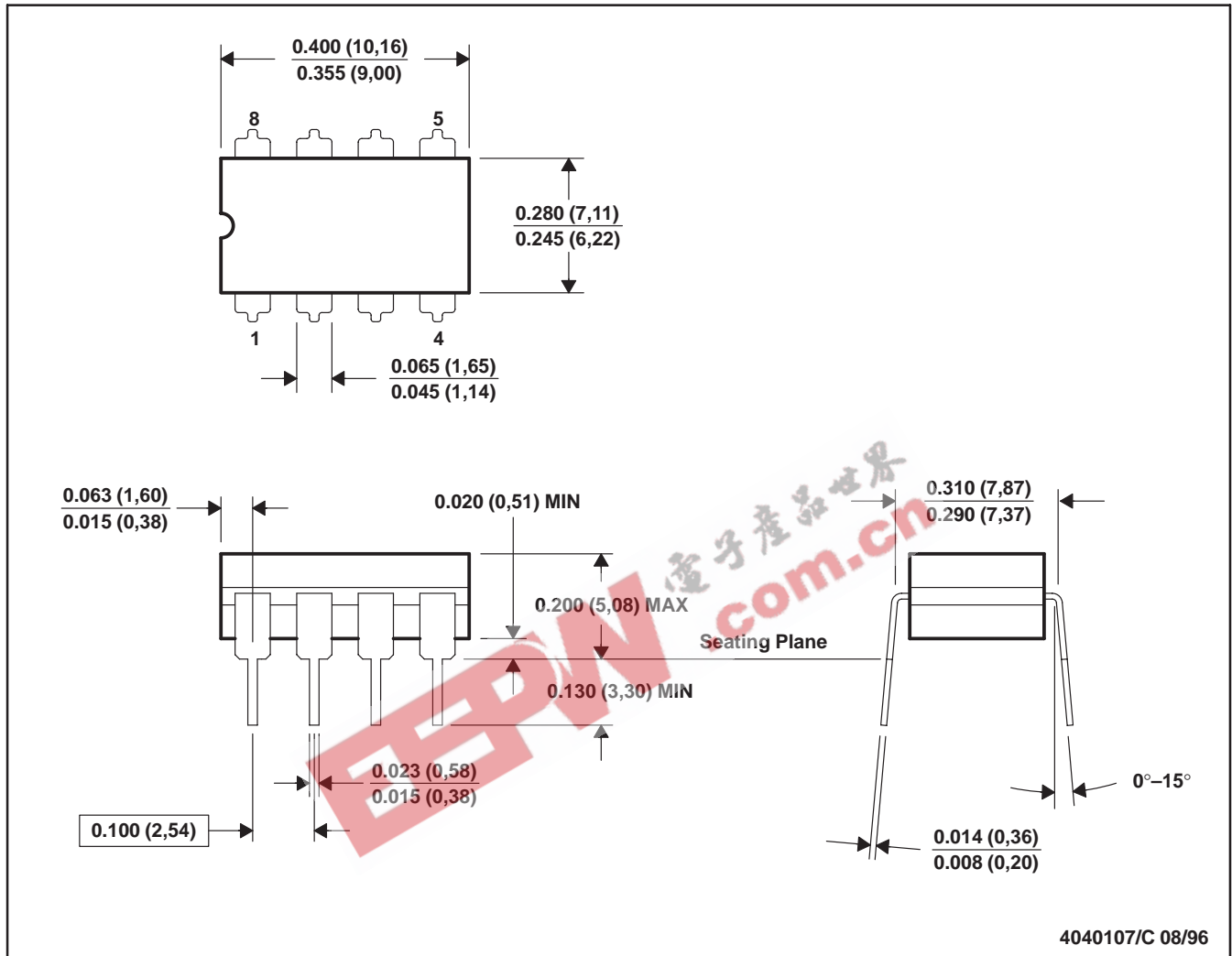

- NOTES: A. All linear dimensions are in inches (millimeters).
 B. This drawing is subject to change without notice.
 C. This package can be hermetically sealed with a ceramic lid using glass frit.
 D. Index point is provided on cap for terminal identification.
 E. Falls within MIL STD 1835 GDIP1-T8

MECHANICAL INFORMATION

P (R-PDIP-T8)

PLASTIC DUAL-IN-LINE PACKAGE

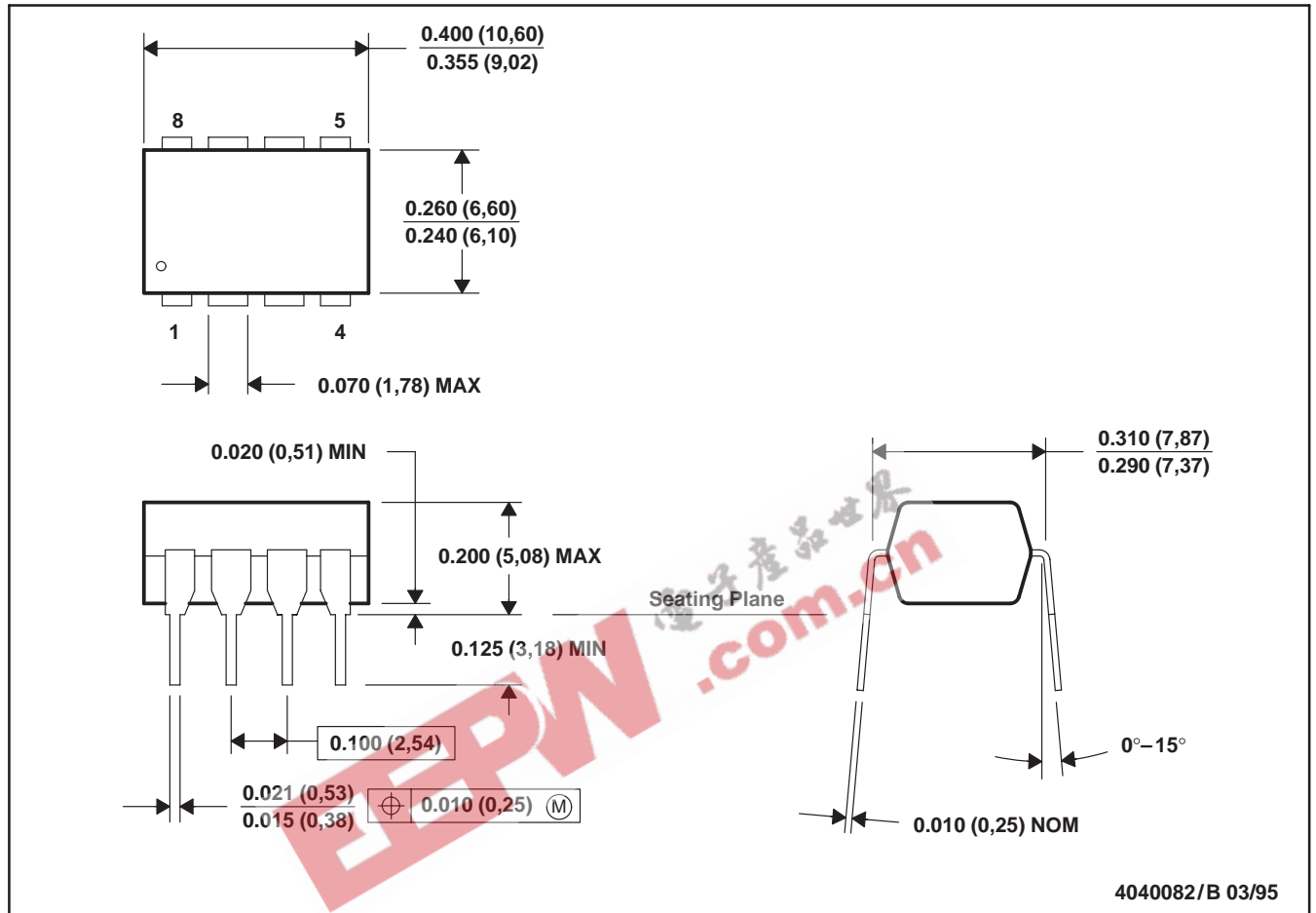

- NOTES: A. All linear dimensions are in inches (millimeters).
 B. This drawing is subject to change without notice.
 C. Falls within JEDEC MS-001

EEPW 电子产品世界
.com.cn

IMPORTANT NOTICE

Texas Instruments and its subsidiaries (TI) reserve the right to make changes to their products or to discontinue any product or service without notice, and advise customers to obtain the latest version of relevant information to verify, before placing orders, that information being relied on is current and complete. All products are sold subject to the terms and conditions of sale supplied at the time of order acknowledgement, including those pertaining to warranty, patent infringement, and limitation of liability.

TI warrants performance of its semiconductor products to the specifications applicable at the time of sale in accordance with TI's standard warranty. Testing and other quality control techniques are utilized to the extent TI deems necessary to support this warranty. Specific testing of all parameters of each device is not necessarily performed, except those mandated by government requirements.

CERTAIN APPLICATIONS USING SEMICONDUCTOR PRODUCTS MAY INVOLVE POTENTIAL RISKS OF DEATH, PERSONAL INJURY, OR SEVERE PROPERTY OR ENVIRONMENTAL DAMAGE ("CRITICAL APPLICATIONS"). TI SEMICONDUCTOR PRODUCTS ARE NOT DESIGNED, AUTHORIZED, OR WARRANTED TO BE SUITABLE FOR USE IN LIFE-SUPPORT DEVICES OR SYSTEMS OR OTHER CRITICAL APPLICATIONS. INCLUSION OF TI PRODUCTS IN SUCH APPLICATIONS IS UNDERSTOOD TO BE FULLY AT THE CUSTOMER'S RISK.

In order to minimize risks associated with the customer's applications, adequate design and operating safeguards must be provided by the customer to minimize inherent or procedural hazards.

TI assumes no liability for applications assistance or customer product design. TI does not warrant or represent that any license, either express or implied, is granted under any patent right, copyright, mask work right, or other intellectual property right of TI covering or relating to any combination, machine, or process in which such semiconductor products or services might be or are used. TI's publication of information regarding any third party's products or services does not constitute TI's approval, warranty or endorsement thereof.