

TL1451A

DUAL PULSE-WIDTH-MODULATION CONTROL CIRCUITS

SLVS024E – FEBRUARY 1983 – REVISED NOVEMBER 1999

- Complete PWM Power Control Circuitry
- Completely Synchronized Operation
- Internal Undervoltage Lockout Protection
- Wide Supply Voltage Range
- Internal Short-Circuit Protection
- Oscillator Frequency . . . 500 kHz Max
- Variable Dead Time Provides Control Over Total Range
- Internal Regulator Provides a Stable 2.5-V Reference Supply
- Available in Q-Temp Automotive HighRel Automotive Applications Configuration Control / Print Support Qualification to Automotive Standards

description

The TL1451A incorporates on a single monolithic chip all the functions required in the construction of two pulse-width-modulation (PWM) control circuits. Designed primarily for power-supply control, the TL1451A contains an on-chip 2.5-V regulator, two error amplifiers, an adjustable oscillator, two dead-time comparators, undervoltage lockout circuitry, and dual common-emitter output transistor circuits.

The uncommitted output transistors provide common-emitter output capability for each controller. The internal amplifiers exhibit a common-mode voltage range from 1.04 V to 1.45 V. The dead-time control (DTC) comparator has no offset unless externally altered and can provide 0% to 100% dead time. The on-chip oscillator can be operated by terminating RT and CT. During low V_{CC} conditions, the undervoltage lockout control circuit feature locks the outputs off until the internal circuitry is operational.

The TL1451AC is characterized for operation from -20°C to 85°C . The TL1451AQ is characterized for operation from -40°C to 125°C . The TL1451AM is characterized for operation from -55°C to 125°C .

D, DB, N, NS, PW, OR J PACKAGE
(TOP VIEW)

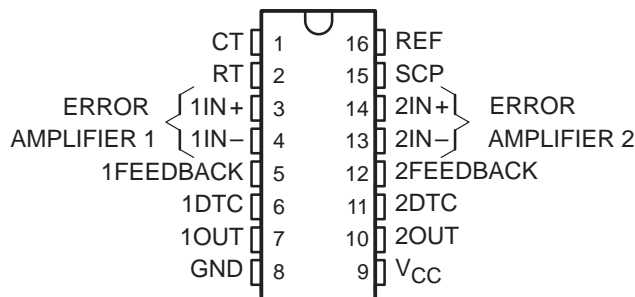

FK PACKAGE
(TOP VIEW)

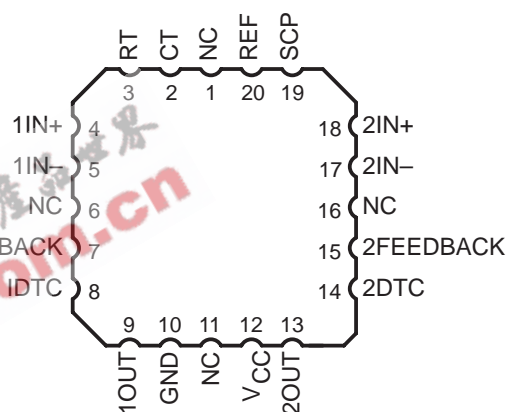

AVAILABLE OPTIONS

T _A	PACKAGED DEVICES						
	SMALL OUTLINE (D)	SMALL OUTLINE (DB)†	PLASTIC DIP (N)	SMALL OUTLINE (NS)	TSSOP (PW)†	CHIP CARRIER (FK)	CERAMIC DIP (J)
-20°C to 85°C	—	TL1451ACDB	TL1451ACN	TL1451ACNS	TL1451ACPW	—	—
-40°C to 125°C	TL1451AQD	—	—	—	—	—	—
-55°C to 125°C	—	—	—	—	—	TL1451AMFK	TL1451AMJ

† The DB and PW packages are only available left-end taped and reeled (add LE suffix, i.e., TL1451ACPWLE).



Please be aware that an important notice concerning availability, standard warranty, and use in critical applications of Texas Instruments semiconductor products and disclaimers thereto appears at the end of this data sheet.

PRODUCTION DATA information is current as of publication date. Products conform to specifications per the terms of Texas Instruments standard warranty. Production processing does not necessarily include testing of all parameters.

TEXAS INSTRUMENTS

POST OFFICE BOX 655303 • DALLAS, TEXAS 75265

Copyright © 1999, Texas Instruments Incorporated
On products compliant to MIL-PRF-38535, all parameters are tested unless otherwise noted. On all other products, production processing does not necessarily include testing of all parameters.

TL1451A DUAL PULSE-WIDTH-MODULATION CONTROL CIRCUITS

SLVS024E – FEBRUARY 1983 – REVISED NOVEMBER 1999

functional block diagram

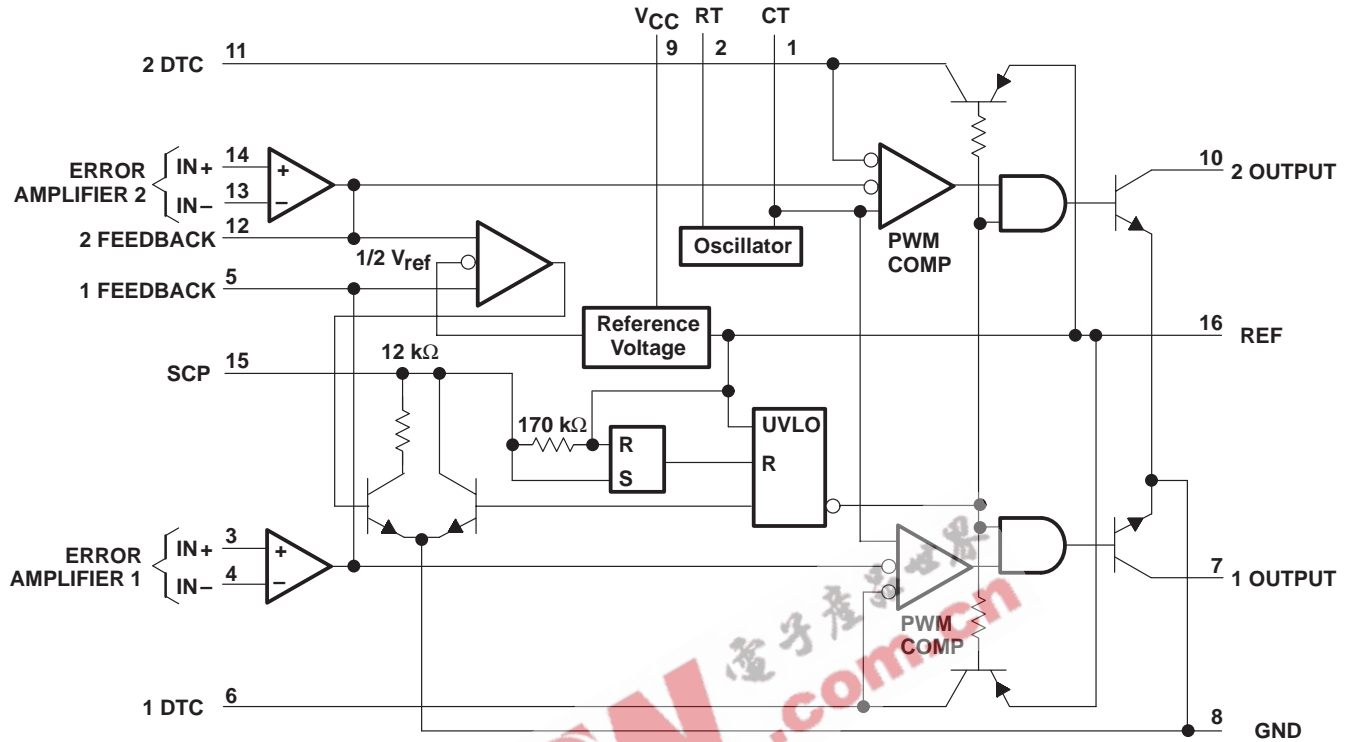

COMPONENT COUNT

Resistors	65
Capacitors	8
Transistors	105
JFETs	18

TL1451A

DUAL PULSE-WIDTH-MODULATION CONTROL CIRCUITS

SLVS024E – FEBRUARY 1983 – REVISED NOVEMBER 1999

absolute maximum ratings over operating free-air temperature range†

Supply voltage, V_{CC}	51 V
Amplifier input voltage, V_I	20 V
Collector output voltage, V_O	51 V
Collector output current, I_O	21 mA
Continuous power total dissipation	See Dissipation Rating Table
Operating free-air temperature range, T_A C suffix	–20°C to 85°C
Q suffix	–40°C to 125°C
M suffix	–55°C to 125°C
Storage temperature range, T_{stg}	–65°C to 150°C
Lead temperature 1,6 mm (1/16 inch) from case for 10 seconds	260°C

† Stresses beyond those listed under “absolute maximum ratings” may cause permanent damage to the device. These are stress ratings only, and functional operation of the device at these or any other conditions beyond those indicated under “recommended operating conditions” is not implied. Exposure to absolute-maximum-rated conditions for extended periods may affect device reliability.

DISSIPATION RATING TABLE

PACKAGE	$T_A \leq 25^\circ\text{C}$ POWER RATING	DERATING FACTOR ABOVE $T_A = 25^\circ\text{C}$	$T_A = 70^\circ\text{C}$ POWER RATING	$T_A = 85^\circ\text{C}$ POWER RATING	$T_A = 125^\circ\text{C}$ POWER RATING
D	1088 mW	8.7 mW/°C	696 mW	566 mW	218 mW
DB	775 mW	6.2 mW/°C	496 mW	403 mW	—
N	1000 mW	8.0 mW/°C	640 mW	520 mW	—
NS	500 mW	4.0 mW/°C	320 mW	260 mW	—
PW	838 mW	6.7 mW/°C	536 mW	436 mW	168 mW
FK	1375 mW	11.0 mW/°C	880 mW	715 mW	275 mW
J	1375 mW	11.0 mW/°C	880 mW	715 mW	275 mW

recommended operating conditions

	MIN	MAX	UNIT
Supply voltage, V_{CC}	3.6	50	V
Amplifier input voltage, V_I	1.05	1.45	V
Collector output voltage, V_O		50	V
Collector output current, I_O		20	mA
Current into feedback terminal		45	μA
Feedback resistor, R_F	100		kΩ
Timing capacitor, C_T	150	15000	pF
Timing resistor, R_T	5.1	100	kΩ
Oscillator frequency	1	500	kHz
Operating free-air temperature, T_A	C suffix	–20	85
	Q suffix	–40	125
	M suffix	–55	125
			°C

TL1451A

DUAL PULSE-WIDTH-MODULATION CONTROL CIRCUITS

SLVS024E – FEBRUARY 1983 – REVISED NOVEMBER 1999

electrical characteristics over recommended operating free-air temperature range, $V_{CC} = 6\text{ V}$, $f = 200\text{ kHz}$ (unless otherwise noted)

reference section

PARAMETER	TEST CONDITIONS	TL1451AC			UNIT
		MIN	TYP†	MAX	
Output voltage (pin 16)	$I_O = 1\text{ mA}$	2.4	2.5	2.6	V
Output voltage change with temperature	$T_A = -20^\circ\text{C}$ to 25°C		-0.1%	$\pm 1\%$	
	$T_A = 25^\circ\text{C}$ to 85°C		-0.2%	$\pm 1\%$	
Input voltage regulation	$V_{CC} = 3.6\text{ V}$ to 40 V		2	12.5	mV
Output voltage regulation	$I_O = 0.1\text{ mA}$ to 1 mA		1	7.5	mV
Short-circuit output current	$V_O = 0$	3	10	30	mA

† All typical values are at $T_A = 25^\circ\text{C}$.

undervoltage lockout section

PARAMETER	TEST CONDITIONS	TL1451AC			UNIT
		MIN	TYP†	MAX	
Upper threshold voltage (V_{CC})	$I_{O(\text{ref})} = 0.1\text{ mA}$, $T_A = 25^\circ\text{C}$		2.72		V
Lower threshold voltage (V_{CC})			2.6		V
Hysteresis (V_{CC})		80	120		mV
Reset threshold voltage (V_{CC})		1.5	1.9		V

† All typical values are at $T_A = 25^\circ\text{C}$.

short-circuit protection control section

PARAMETER	TEST CONDITIONS	TL1451AC			UNIT
		MIN	TYP†	MAX	
Input threshold voltage (SCP)	$T_A = 25^\circ\text{C}$	0.65	0.7	0.75	V
Standby voltage (SCP)	No pullup	140	185	230	mV
Latched input voltage (SCP)	No pullup		60	120	mV
Input (source) current	$V_I = 0.7\text{ V}$, $T_A = 25^\circ\text{C}$	-10	-15	-20	μA
Comparator threshold voltage (FEEDBACK)			1.18		V

† All typical values are at $T_A = 25^\circ\text{C}$.

oscillator section

PARAMETER	TEST CONDITIONS	TL1451C			UNIT
		MIN	TYP†	MAX	
Frequency	$C_T = 330\text{ pF}$, $R_T = 10\text{ k}\Omega$		200		kHz
Standard deviation of frequency	$C_T = 330\text{ pF}$, $R_T = 10\text{ k}\Omega$		10%		
Frequency change with voltage	$V_{CC} = 3.6\text{ V}$ to 40 V		1%		
Frequency change with temperature	$T_A = -20^\circ\text{C}$ to 25°C		-0.4%	$\pm 2\%$	
	$T_A = 25^\circ\text{C}$ to 85°C		-0.2%	$\pm 2\%$	

† All typical values are at $T_A = 25^\circ\text{C}$.

TL1451A

DUAL PULSE-WIDTH-MODULATION CONTROL CIRCUITS

SLVS024E – FEBRUARY 1983 – REVISED NOVEMBER 1999

dead-time control section

PARAMETER	TEST CONDITIONS	TL1451AC			UNIT
		MIN	TYP†	MAX	
Input bias current (DTC)				1	μA
Latch mode (source) current (DTC)	T _A = 25°C	-80	-145		μA
Latched input voltage (DTC)	I _O = 40 μA	2.3			V
Input threshold voltage at f = 10 kHz (DTC)	Zero duty cycle		2.05	2.25	V
	Maximum duty cycle	1.2	1.45		

† All typical values are at T_A = 25°C.

error-amplifier section

PARAMETER	TEST CONDITIONS	TL1451AC			UNIT
		MIN	TYP†	MAX	
Input offset voltage	V _O (FEEDBACK) = 1.25 V			±6	mV
Input offset current	V _O (FEEDBACK) = 1.25 V			±100	nA
Input bias current	V _O (FEEDBACK) = 1.25 V		160	500	nA
Common-mode input voltage range	V _{CC} = 3.6 V to 40 V	1.05 to 1.45			V
Open-loop voltage amplification	R _F = 200 kΩ	70	80		dB
Unity-gain bandwidth			1.5		MHz
Common-mode rejection ratio		60	80		dB
Positive output voltage swing				V _{ref} -0.1	V
Negative output voltage swing				1	V
Output (sink) current (FEEDBACK)	V _{ID} = -0.1 V, V _O = 1.25 V	0.5	1.6		mA
Output (source) current (FEEDBACK)	V _{ID} = 0.1 V, V _O = 1.25 V	-45	-70		μA

† All typical values are at T_A = 25°C.

output section

PARAMETER	TEST CONDITIONS	TL1451AC			UNIT
		MIN	TYP†	MAX	
Collector off-state current	V _O = 50 V			10	μA
Output saturation voltage	I _O = 10 mA		1.2	2	V
Short-circuit output current	V _O = 6 V		90		mA

† All typical values are at T_A = 25°C.

pwm comparator section

PARAMETER	TEST CONDITIONS	TL1451AC			UNIT
		MIN	TYP†	MAX	
Input threshold voltage at f = 10 kHz (FEEDBACK)	Zero duty cycle		2.05	2.25	V
	Maximum duty cycle	1.2	1.45		

† All typical values are at T_A = 25°C.

total device

PARAMETER	TEST CONDITIONS	TL1451AC			UNIT
		MIN	TYP†	MAX	
Standby supply current	Off-state		1.3	1.8	mA
Average supply current	R _T = 10 kΩ		1.7	2.4	mA

† All typical values are at T_A = 25°C.

TL1451A

DUAL PULSE-WIDTH-MODULATION CONTROL CIRCUITS

SLVS024E – FEBRUARY 1983 – REVISED NOVEMBER 1999

electrical characteristics over recommended operating free-air temperature range, $V_{CC} = 6\text{ V}$, $f = 200\text{ kHz}$ (unless otherwise noted)

reference section

PARAMETER	TEST CONDITIONS	TL1451AQ, TL1451AM			UNIT	
		MIN	TYP†	MAX		
Output voltage (pin 16)	$I_O = 1\text{ mA}$	$T_A = 25^\circ\text{C}$	2.40	2.50	2.60	V
		$T_A = \text{MIN and } 125^\circ\text{C}$	2.35	2.46	2.65	
Output voltage change with temperature			-0.63%	*±4%		
Input voltage regulation	$V_{CC} = 3.6\text{ V to } 40\text{ V}$	$T_A = 25^\circ\text{C}$		2.0	12.5	mV
		$T_A = 125^\circ\text{C}$		0.7	15	
		$T_A = \text{MIN}$		0.3	30	
Output voltage regulation	$I_O = 0.1\text{ mA to } 1\text{ mA}$	$T_A = 25^\circ\text{C}$		1.0	7.5	mV
		$T_A = 125^\circ\text{C}$		0.3	14	
		$T_A = \text{MIN}$		0.3	20	
Short-circuit output current	$V_O = 0$		3	10	30	mA

*These parameters are not production tested.

† All typical values are at $T_A = 25^\circ\text{C}$ unless otherwise indicated.

undervoltage lockout section

PARAMETER	TEST CONDITIONS	TL1451AQ, TL1451AM			UNIT
		MIN	TYP†	MAX	
Upper threshold voltage (V_{CC})	$T_A = 25^\circ\text{C}$			2.72	V
	$T_A = 125^\circ\text{C}$			1.70	
	$T_A = \text{MIN}$			3.15	
Lower threshold voltage (V_{CC})	$T_A = 25^\circ\text{C}$			2.60	V
	$T_A = 125^\circ\text{C}$			1.65	
	$T_A = \text{MIN}$			3.09	
Hysteresis (V_{CC})	$T_A = 25^\circ\text{C}$	80	120		mV
	$T_A = 125^\circ\text{C}$	10	50		
	$T_A = \text{MIN}$	10	60		
Reset threshold voltage (V_{CC})	$T_A = 25^\circ\text{C}$			1.50	V
	$T_A = 125^\circ\text{C}$			0.95	
	$T_A = \text{MIN}$			1.50	

† All typical values are at $T_A = 25^\circ\text{C}$ unless otherwise indicated.

TL1451A

DUAL PULSE-WIDTH-MODULATION CONTROL CIRCUITS

SLVS024E – FEBRUARY 1983 – REVISED NOVEMBER 1999

short-circuit protection control section

PARAMETER	TEST CONDITIONS	TL1451AQ, TL1451AM			UNIT
		MIN	TYP†	MAX	
Input threshold voltage (SCP)	T _A = 25°C	650	700	750	mV
	T _A = 125°C	400	478	550	
	T _A = MIN	800	880	950	
Standby voltage (SCP)		140	185	230	mV
Latched input voltage (SCP)	T _A = 25°C		60	120	mV
	T _A = 125°C		70	120	
	T _A = MIN		60	120	
Equivalent timing resistance			170		kΩ
Comparator threshold voltage (FEEDBACK)			1.18		V

† All typical values are at T_A = 25°C unless otherwise indicated.

oscillator section

PARAMETER	TEST CONDITIONS	TL1451AQ, TL1451AM			UNIT
		MIN	TYP†	MAX	
Frequency	C _T = 330 pF, R _T = 10 kΩ	T _A = 25°C	200		kHz
		T _A = 125°C	195		
		T _A = MIN	193		
Standard deviation of frequency	C _T = 330 pF, R _T = 10 kΩ	2%			
Frequency change with voltage	V _{CC} = 3.6 V to 40 V	T _A = 25°C	1%		
		T _A = 125°C	1%		
		T _A = MIN	3%		
Frequency change with temperature		1.37% ±10%			

*These parameters are not production tested.

† All typical values are at T_A = 25°C unless otherwise indicated.

dead-time control section

PARAMETER	TEST CONDITIONS	TL1451AQ, TL1451AM			UNIT
		MIN	TYP†	MAX	
Input bias current (DTC)	T _A = 25°C			1	μA
	T _A = MIN and 125°C			3	
Latch mode (source) current (DTC)		-80	-145		μA
Latched input voltage (DTC)	T _A = 25°C	2.30			V
	T _A = 125°C	2.22	2.32		
	T _A = MIN	2.28	2.40		
Input threshold voltage at f = 10 kHz (DTC)	Zero duty cycle		2.05	*2.25	V
	Maximum duty cycle	*1.20	1.45		

*These parameters are not production tested.

† All typical values are at T_A = 25°C unless otherwise indicated.

TL1451A

DUAL PULSE-WIDTH-MODULATION CONTROL CIRCUITS

SLVS024E – FEBRUARY 1983 – REVISED NOVEMBER 1999

error-amplifier section

PARAMETER	TEST CONDITIONS	TL1451AQ, TL1451AM			UNIT
		MIN	TYP†	MAX	
Input offset voltage	V_O (FEEDBACK) = 1.25 V	$T_A = 25^\circ\text{C}$	±6		mV
		$T_A = 125^\circ\text{C}$	±10		
		$T_A = \text{MIN}$	±12		
Input offset current	V_O (FEEDBACK) = 1.25 V	$T_A = 25^\circ\text{C}$	±100		nA
		$T_A = 125^\circ\text{C}$	±100		
		$T_A = \text{MIN}$	±200		
Input bias current	V_O (FEEDBACK) = 1.25 V	$T_A = 25^\circ\text{C}$	160	500	nA
		$T_A = 125^\circ\text{C}$	100	500	
		$T_A = \text{MIN}$	142	700	
Common-mode input voltage range	$V_{CC} = 3.6 \text{ V to } 40 \text{ V}$	1.05 to 1.45			V
Open-loop voltage amplification	$R_F = 200 \text{ k}\Omega$	$T_A = 25^\circ\text{C}$	70	80	dB
		$T_A = 125^\circ\text{C}$	70	80	
		$T_A = \text{MIN}$	64	80	
Unity-gain bandwidth			1.5	MHz	
Common-mode rejection ratio			60	80	dB
Positive output voltage swing			2	V	
Negative output voltage swing				1	V
Output (sink) current (FEEDBACK)	$V_{ID} = -0.1 \text{ V}, V_O = 1.25 \text{ V}$	$T_A = 25^\circ\text{C}$	0.5	1.6	mA
		$T_A = 125^\circ\text{C}$	0.4	1.8	
		$T_A = \text{MIN}$	0.3	1.7	
Output (source) current (FEEDBACK)	$V_{ID} = 0.1 \text{ V}, V_O = 1.25 \text{ V}$	$T_A = 25^\circ\text{C}$	-45	-70	μA
		$T_A = 125^\circ\text{C}$	-25	-50	
		$T_A = \text{MIN}$	-15	-70	

† All typical values are at $T_A = 25^\circ\text{C}$ unless otherwise indicated.

output section

PARAMETER	TEST CONDITIONS	TL1451AQ, TL1451AM			UNIT
		MIN	TYP†	MAX	
Collector off-state current	$V_O = 50 \text{ V}$			10	μA
Output saturation voltage	$T_A = 25^\circ\text{C}$		1.20	2.0	V
	$T_A = 125^\circ\text{C}$		1.60	2.4	
	$T_A = \text{MIN}$		1.36	2.2	
Short-circuit output current	$V_O = 6 \text{ V}$		90	mA	

† All typical values are at $T_A = 25^\circ\text{C}$ unless otherwise indicated.

pwm comparator section

PARAMETER	TEST CONDITIONS	TL1451AQ, TL1451AM			UNIT
		MIN	TYP†	MAX	
Input threshold voltage at $f = 10 \text{ kHz}$ (FEEDBACK)	Zero duty cycle		2.05	*2.25	V
	Maximum duty cycle	*1.20	1.45		

*These parameters are not production tested.

† All typical values are at $T_A = 25^\circ\text{C}$ unless otherwise indicated.

TL1451A DUAL PULSE-WIDTH-MODULATION CONTROL CIRCUITS

SLVS024E – FEBRUARY 1983 – REVISED NOVEMBER 1999

total device

PARAMETER	TEST CONDITIONS	TL1451AQ, TL1451AM			UNIT
		MIN	TYP†	MAX	
Standby supply current	Off-state		1.3	1.8	mA
Average supply current	$R_T = 10\text{ k}\Omega$		1.7	2.4	mA

† All typical values are at $T_A = 25^\circ\text{C}$ unless otherwise indicated.

PARAMETER MEASUREMENT INFORMATION

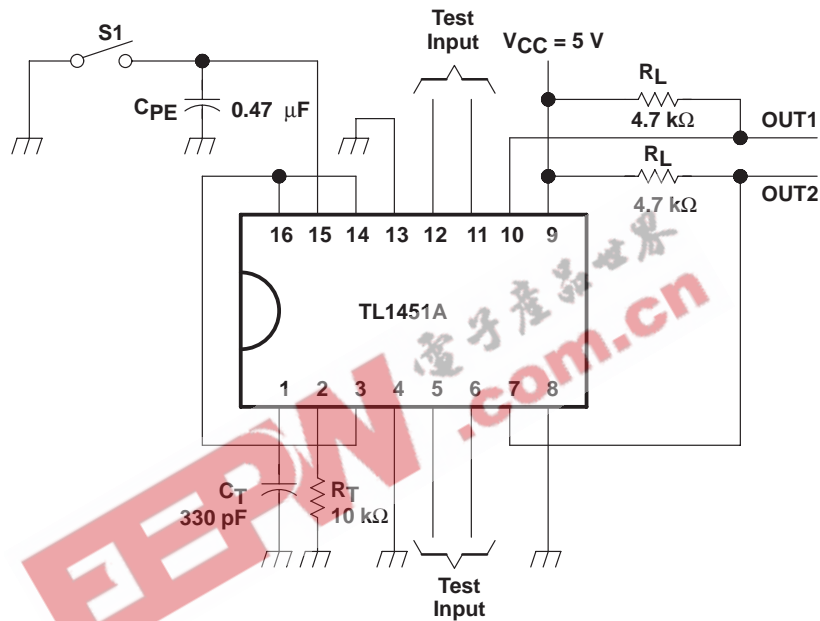
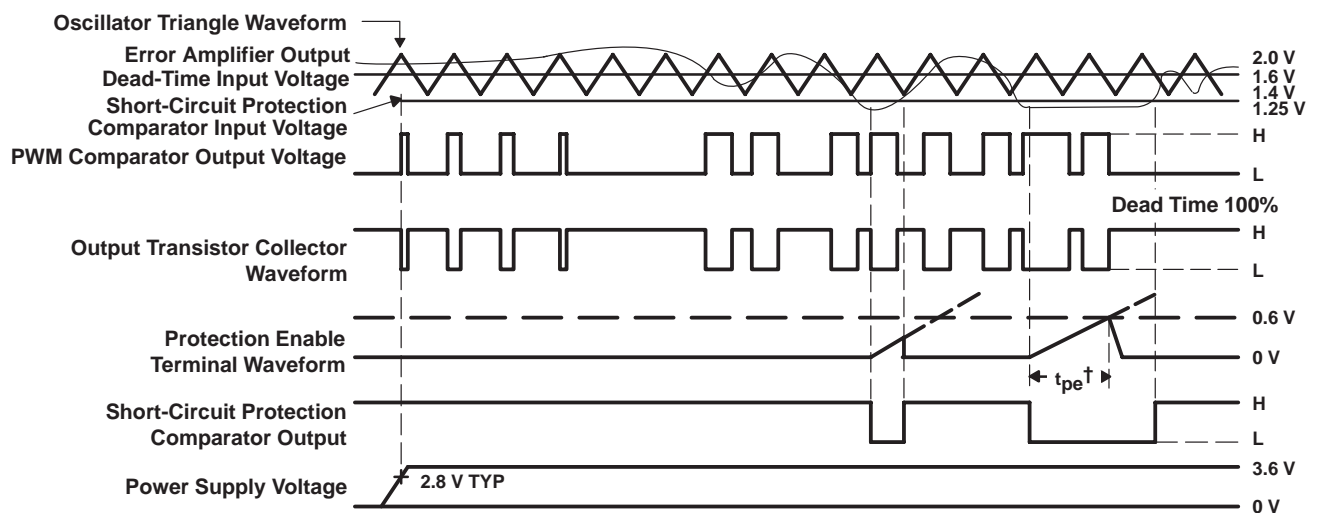

Figure 1. Test Circuit



† Protection Enable Time, $t_{pe} = (0.051 \times 10^6 \times C_{pe})$ in seconds

Figure 2. TL1451A Timing Diagram

TL1451A DUAL PULSE-WIDTH-MODULATION CONTROL CIRCUITS

SLVS024E – FEBRUARY 1983 – REVISED NOVEMBER 1999

TYPICAL CHARACTERISTICS

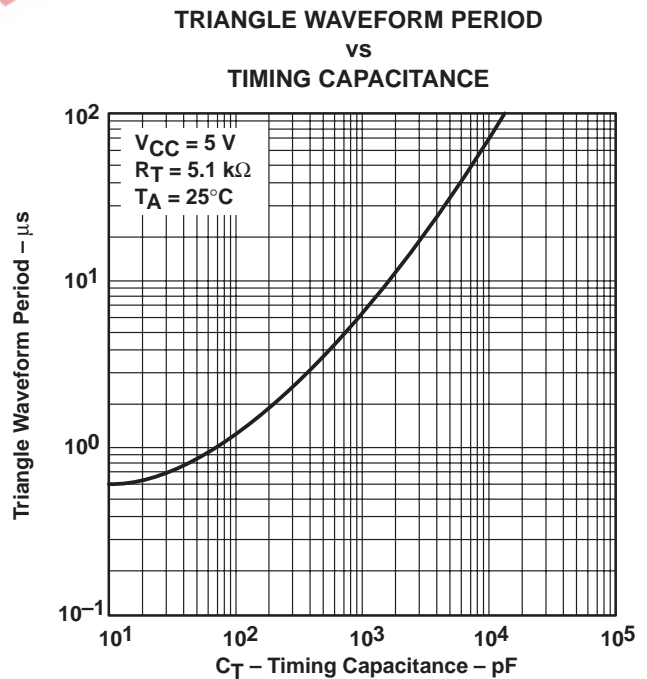
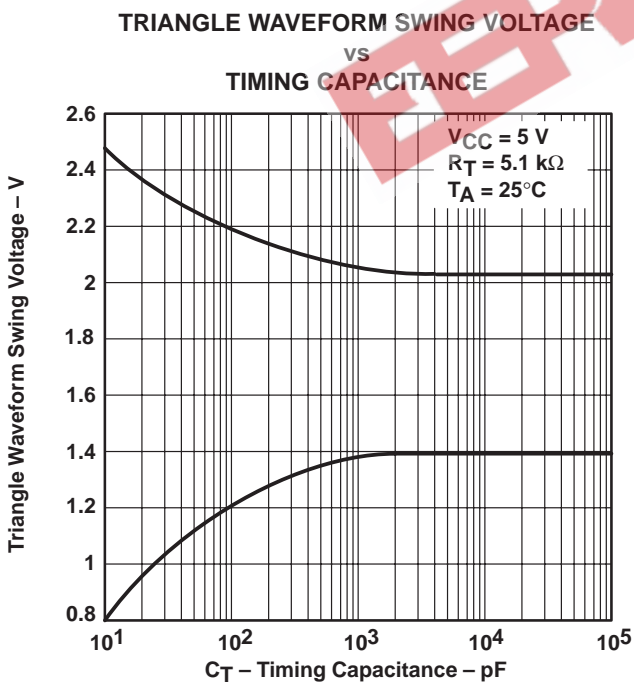
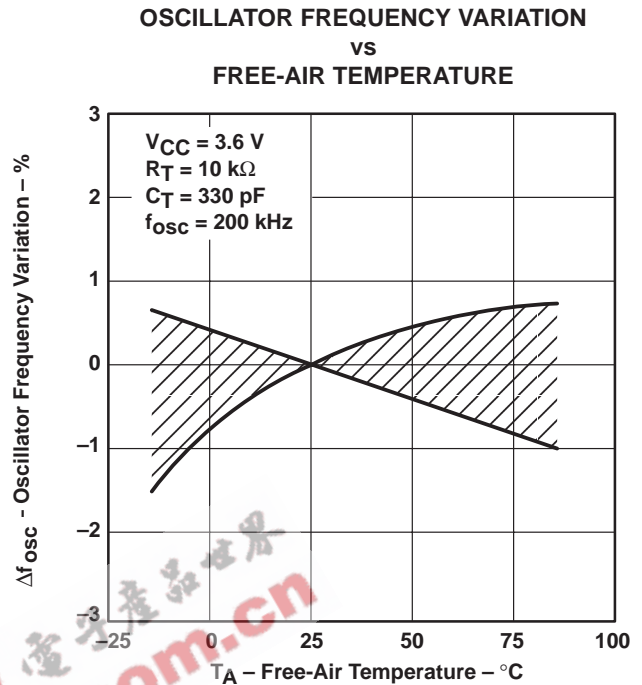
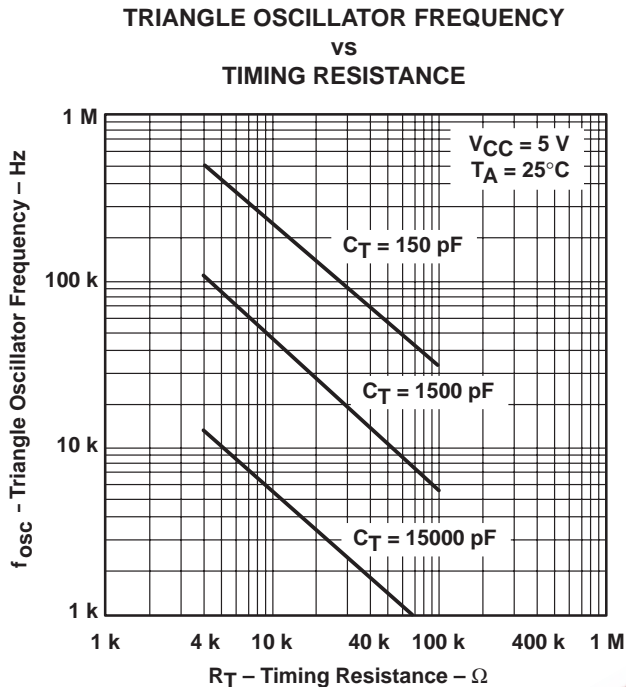

TYPICAL CHARACTERISTICS

REFERENCE OUTPUT VOLTAGE VARIATION
 VS
 FREE-AIR TEMPERATURE

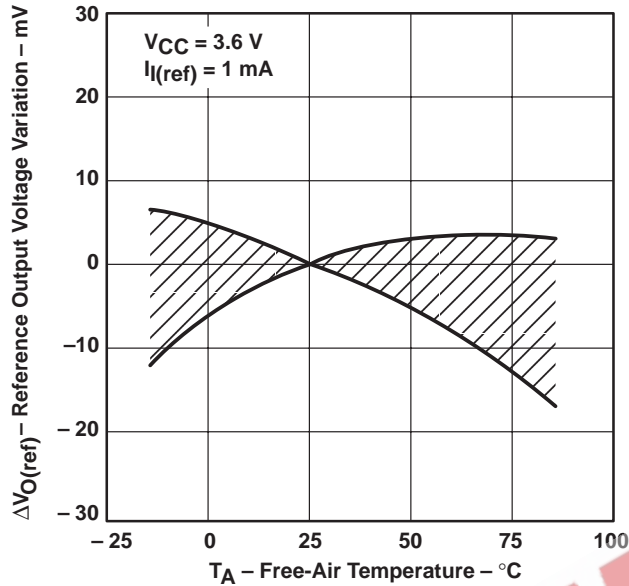

Figure 7

REFERENCE OUTPUT VOLTAGE VARIATION
 VS
 FREE-AIR TEMPERATURE

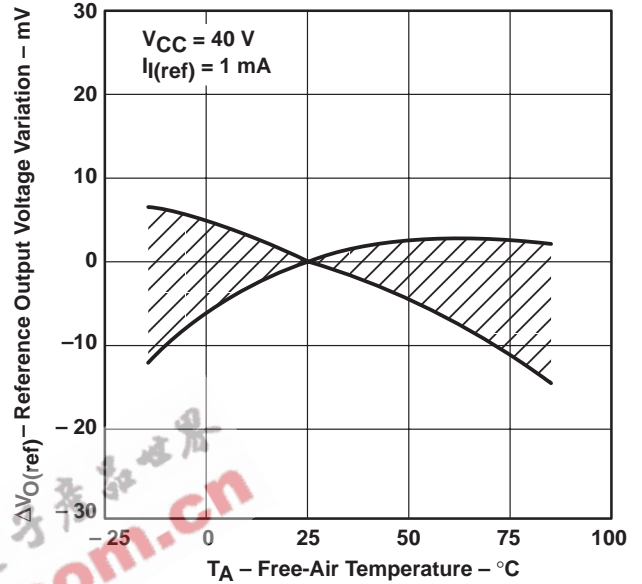

Figure 8

REFERENCE OUTPUT VOLTAGE
 VS
 SUPPLY VOLTAGE

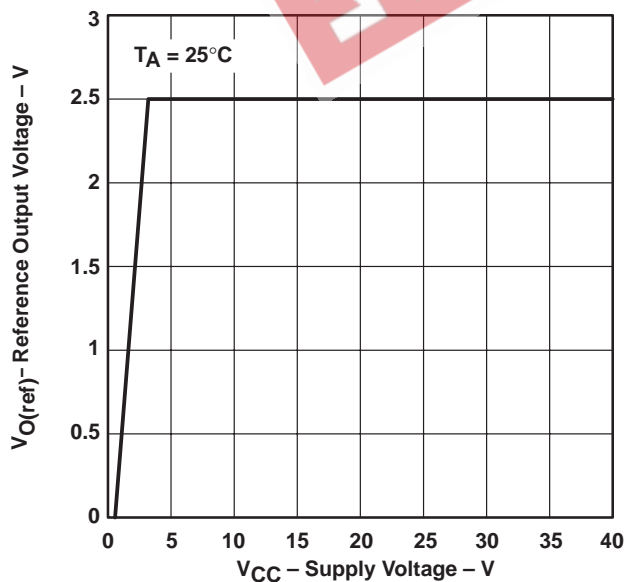

Figure 9

DROPOUT VOLTAGE VARIATION
 VS
 FREE-TEMPERATURE

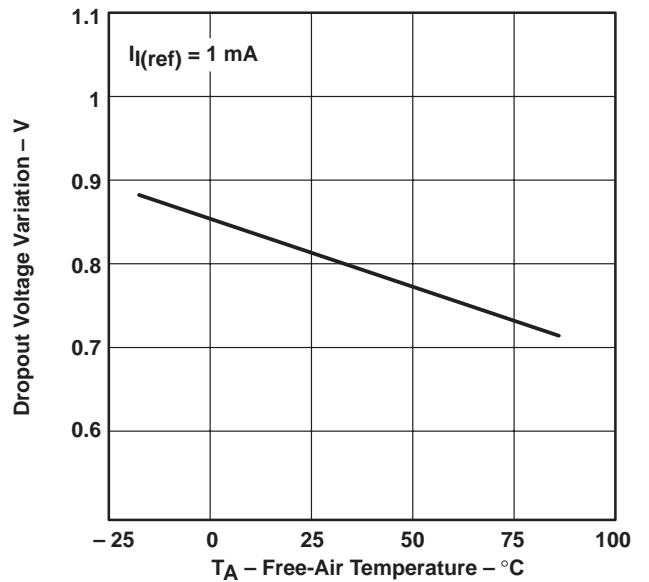

Figure 10

TL1451A DUAL PULSE-WIDTH-MODULATION CONTROL CIRCUITS

SLVS024E – FEBRUARY 1983 – REVISED NOVEMBER 1999

TYPICAL CHARACTERISTICS

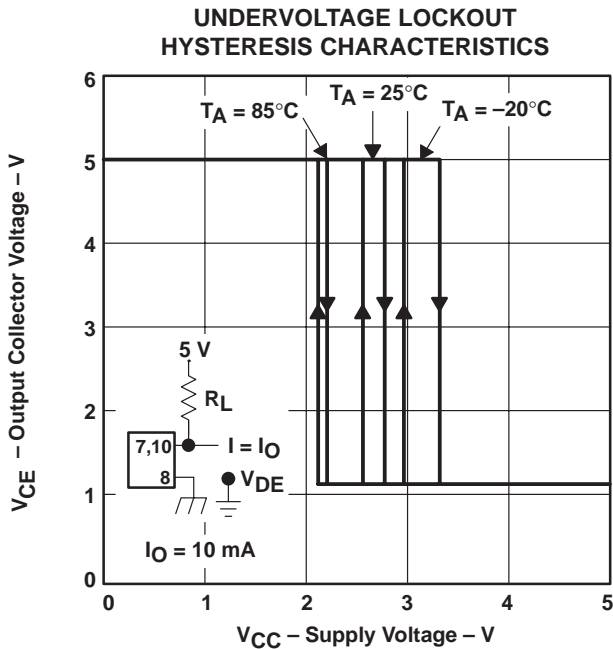

Figure 11

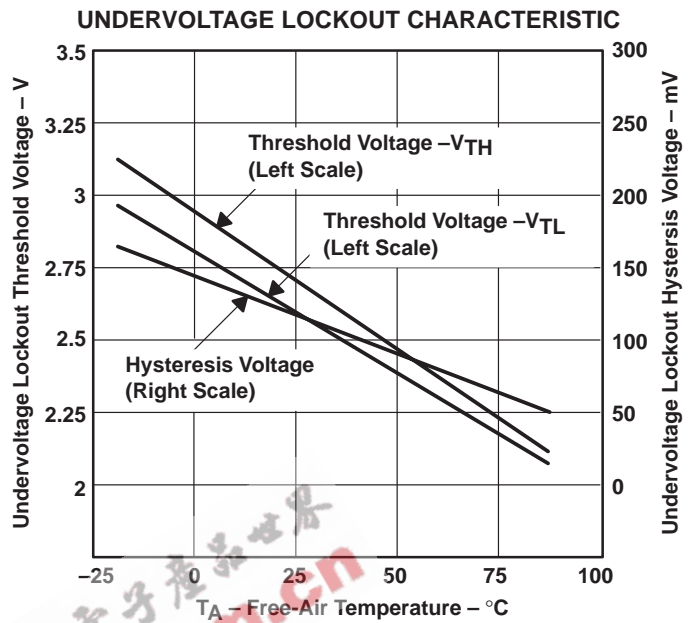

Figure 12

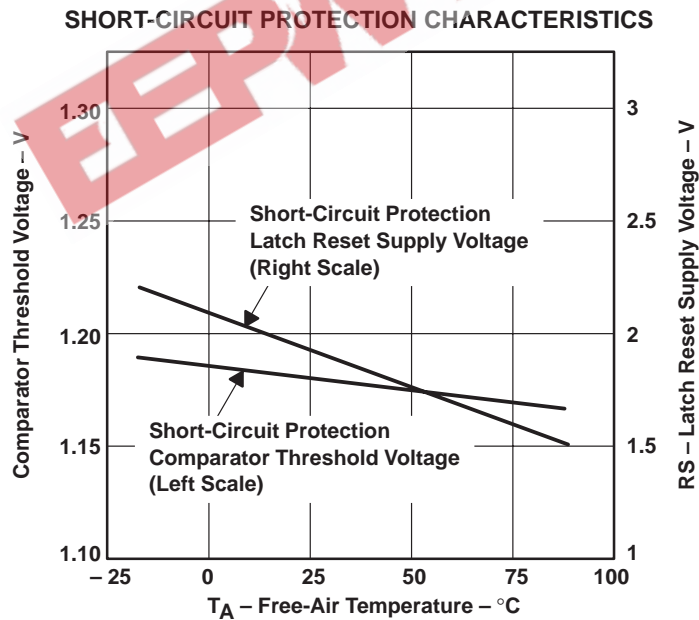

Figure 13

TL1451A DUAL PULSE-WIDTH-MODULATION CONTROL CIRCUITS

SLVS024E – FEBRUARY 1983 – REVISED NOVEMBER 1999

TYPICAL CHARACTERISTICS

PROTECTION ENABLE TIME
VS
PROTECTION ENABLE CAPACITANCE

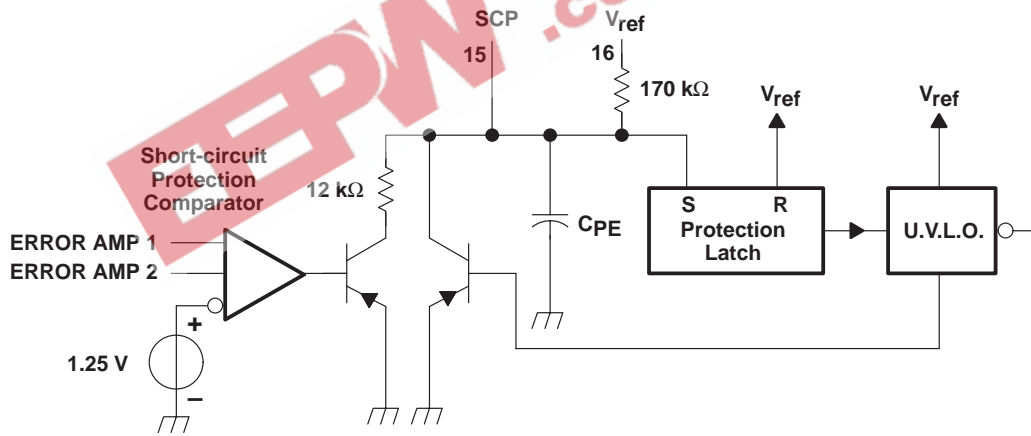
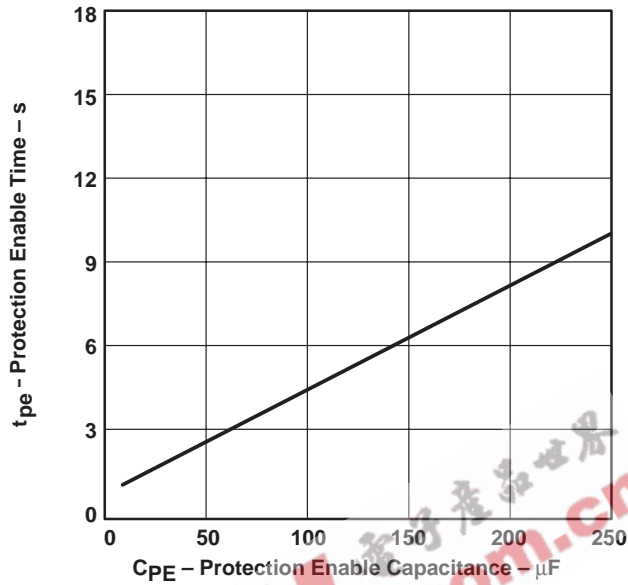

Figure 14

TL1451A DUAL PULSE-WIDTH-MODULATION CONTROL CIRCUITS

SLVS024E – FEBRUARY 1983 – REVISED NOVEMBER 1999

TYPICAL CHARACTERISTICS

**ERROR AMP MAXIMUM OUTPUT VOLTAGE SWING
VS
FREQUENCY**

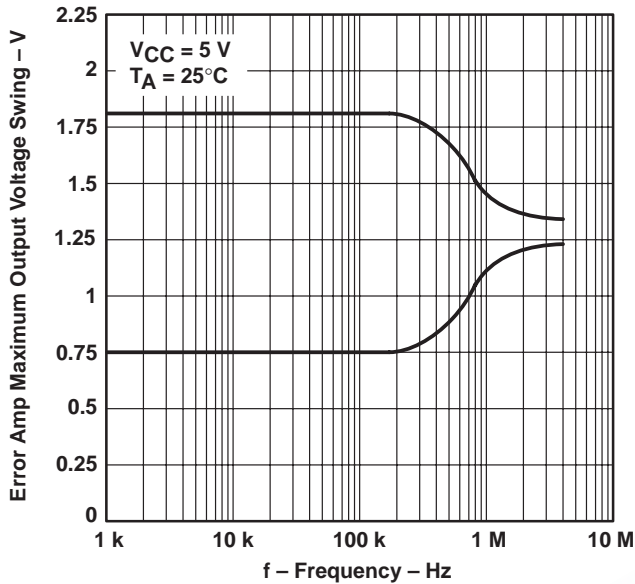

Figure 15

**OPEN-LOOP VOLTAGE AMPLIFICATION
VS
FREQUENCY**

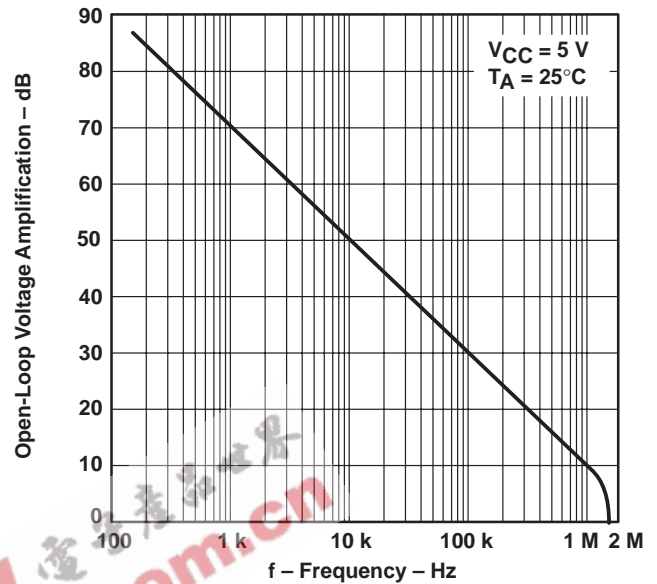

Figure 16

**GAIN (AMPLIFIER IN
UNITY-GAIN CONFIGURATION)
VS
FREQUENCY**

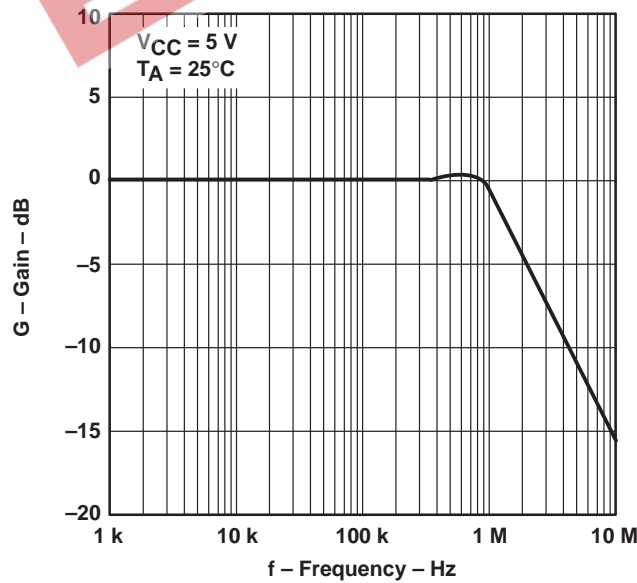
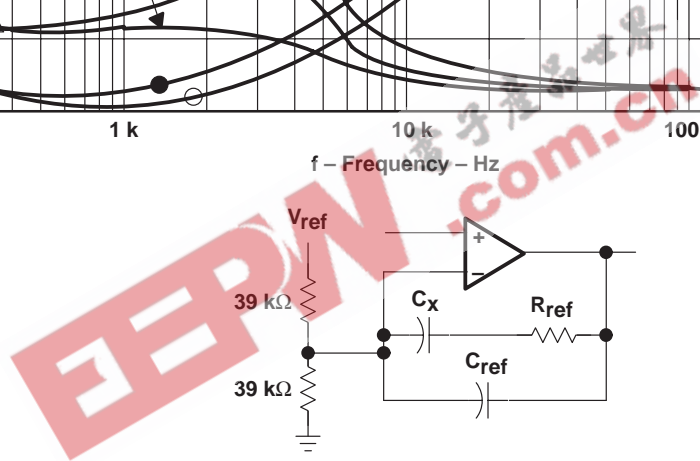
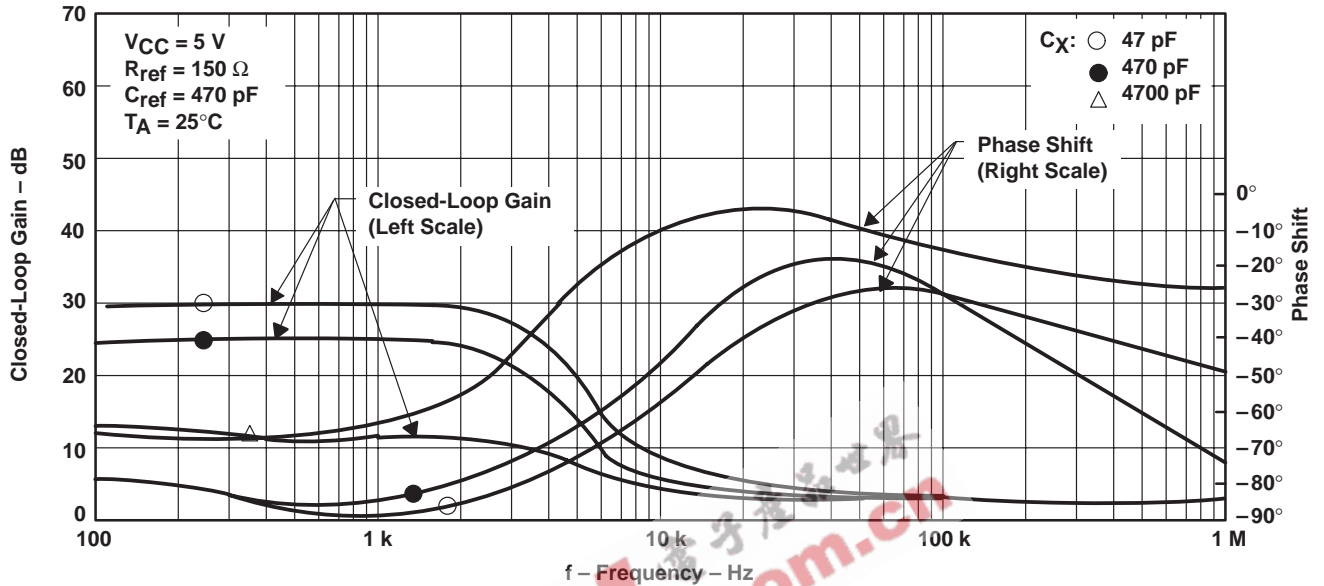

Figure 17

TYPICAL CHARACTERISTICS

CLOSED-LOOP GAIN AND PHASE SHIFT
 VS
 FREQUENCY



Test Circuit

Figure 18

TL1451A DUAL PULSE-WIDTH-MODULATION CONTROL CIRCUITS

SLVS024E – FEBRUARY 1983 – REVISED NOVEMBER 1999

TYPICAL CHARACTERISTICS

CLOSED-LOOP GAIN AND PHASE SHIFT VS FREQUENCY

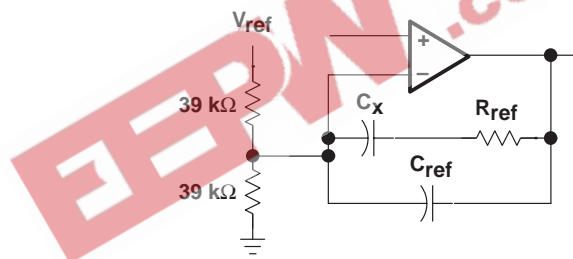
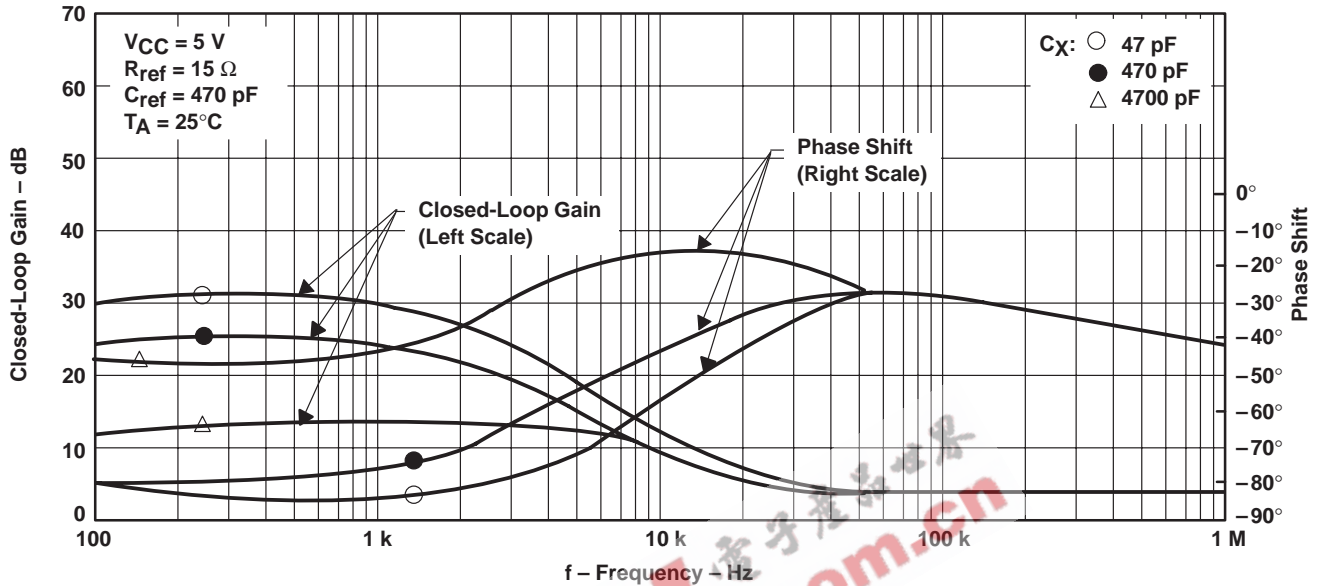

Test Circuit

Figure 19

TYPICAL CHARACTERISTICS

CLOSED-LOOP GAIN AND PHASE SHIFT
 VS
 FREQUENCY

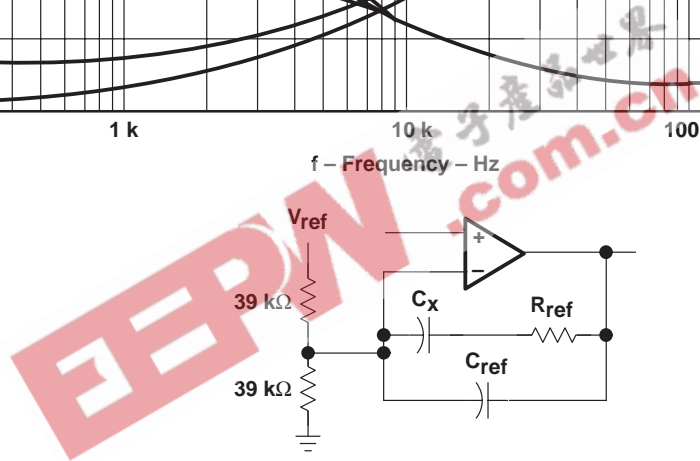
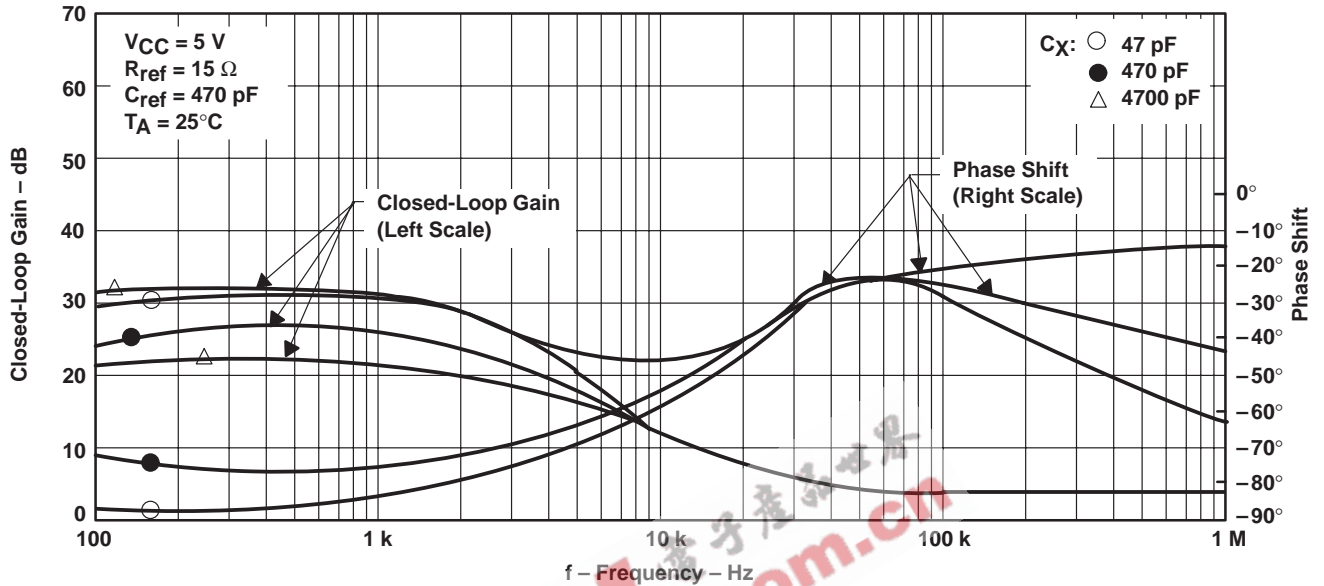

Test Circuit

Figure 20

TL1451A DUAL PULSE-WIDTH-MODULATION CONTROL CIRCUITS

SLVS024E – FEBRUARY 1983 – REVISED NOVEMBER 1999

TYPICAL CHARACTERISTICS

CLOSED-LOOP GAIN AND PHASE SHIFT VS FREQUENCY

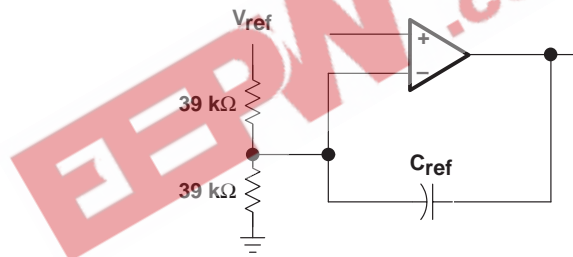
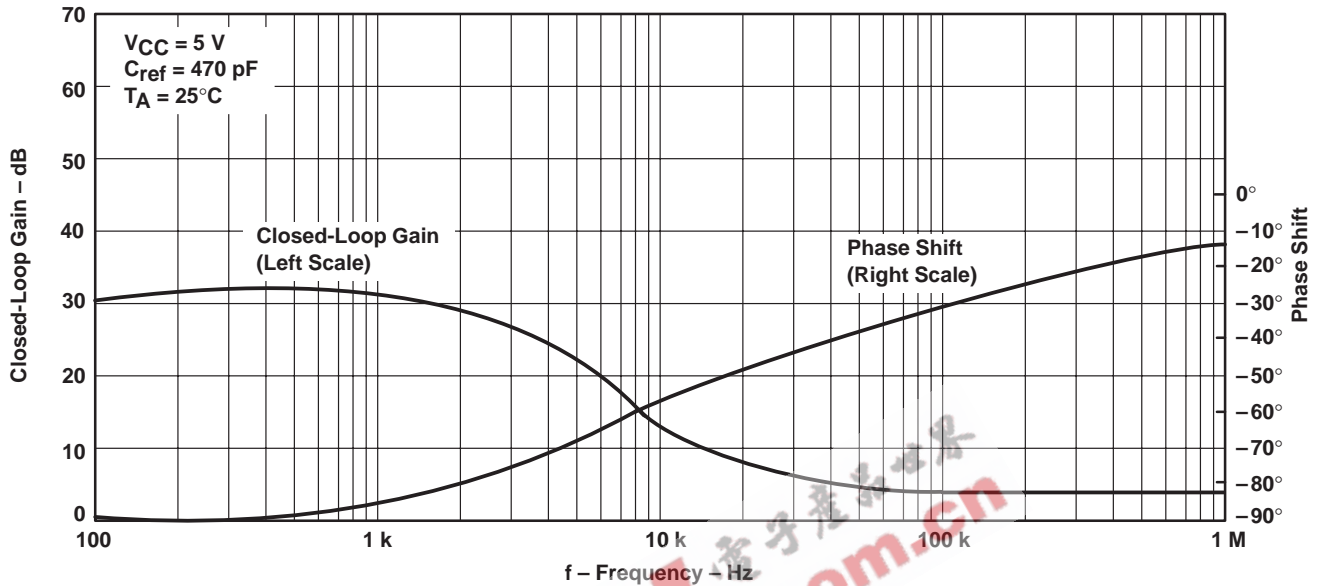

Test Circuit

Figure 21

TYPICAL CHARACTERISTICS

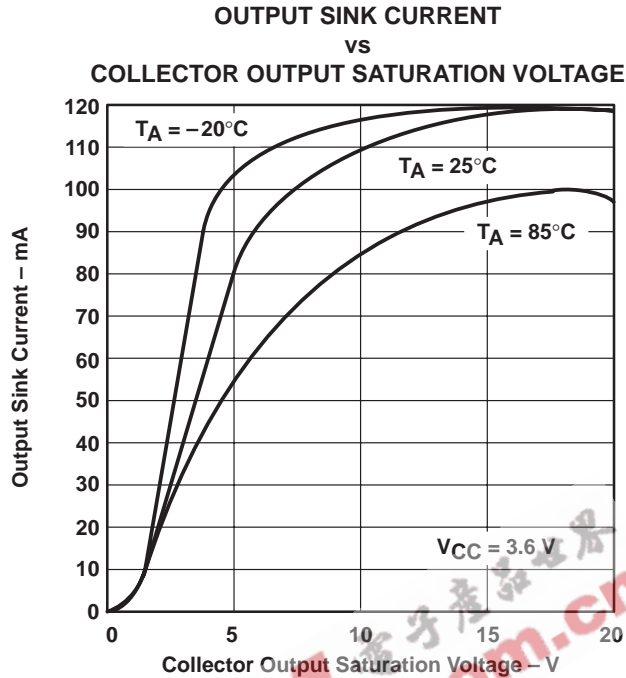

Figure 22

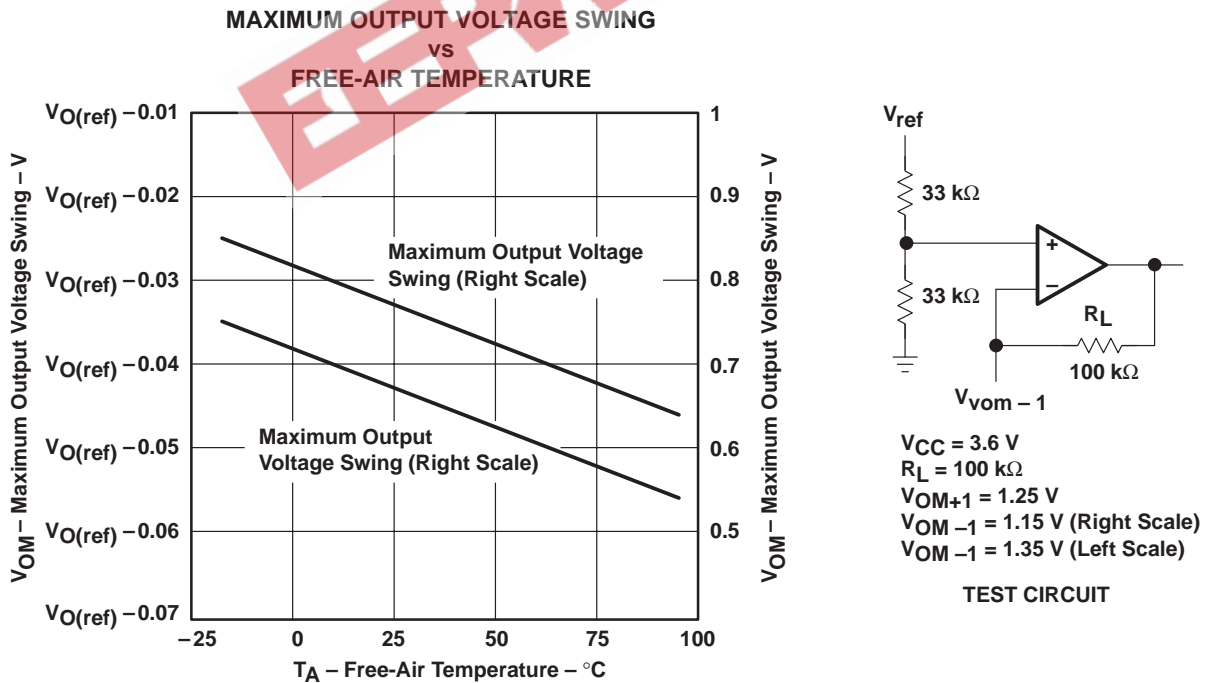

Figure 23

TL1451A DUAL PULSE-WIDTH-MODULATION CONTROL CIRCUITS

SLVS024E – FEBRUARY 1983 – REVISED NOVEMBER 1999

TYPICAL CHARACTERISTICS

OUTPUT TRANSISTOR "On" DUTY CYCLE
vs
DEAD-TIME INPUT VOLTAGE

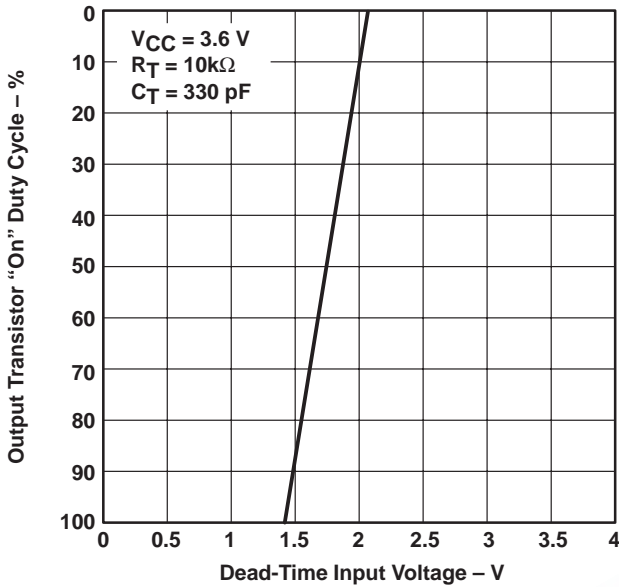

Figure 24

STANDBY CURRENT
vs
SUPPLY VOLTAGE

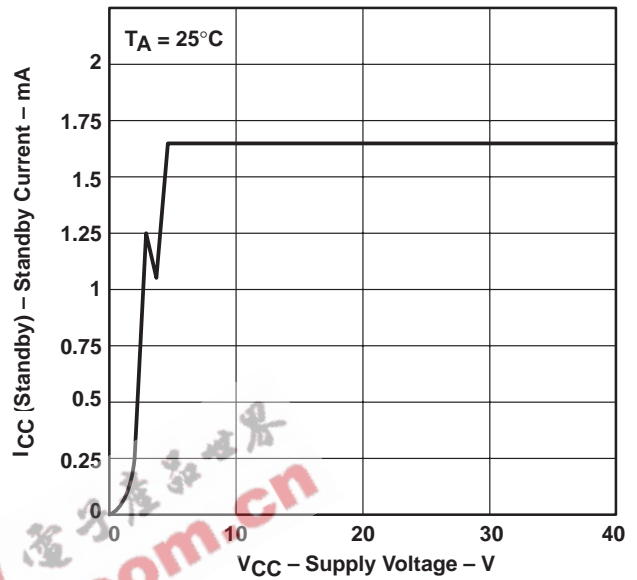

Figure 25

STANDBY CURRENT
vs
FREE-AIR TEMPERATURE

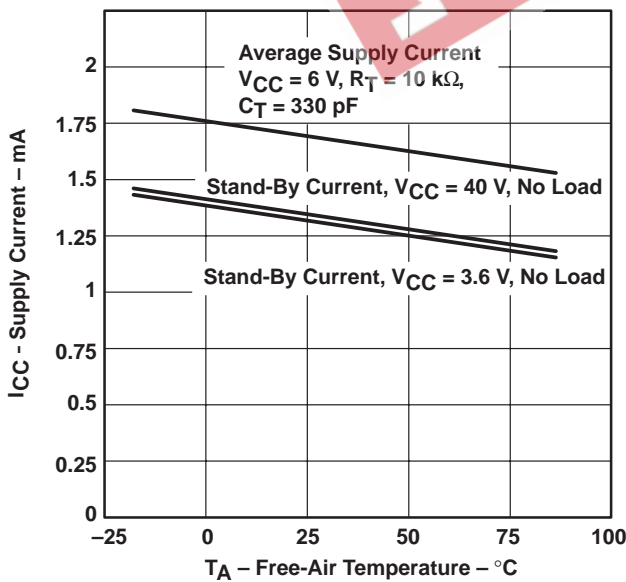

Figure 26

MAXIMUM CONTINUOUS POWER DISSIPATION
vs
FREE-AIR TEMPERATURE

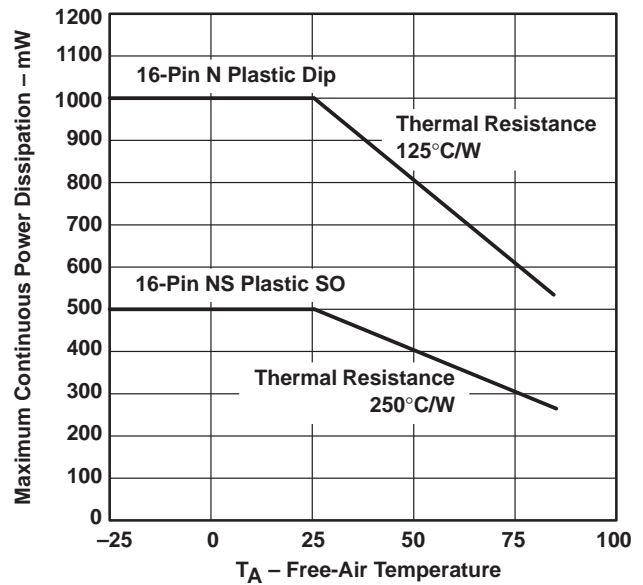
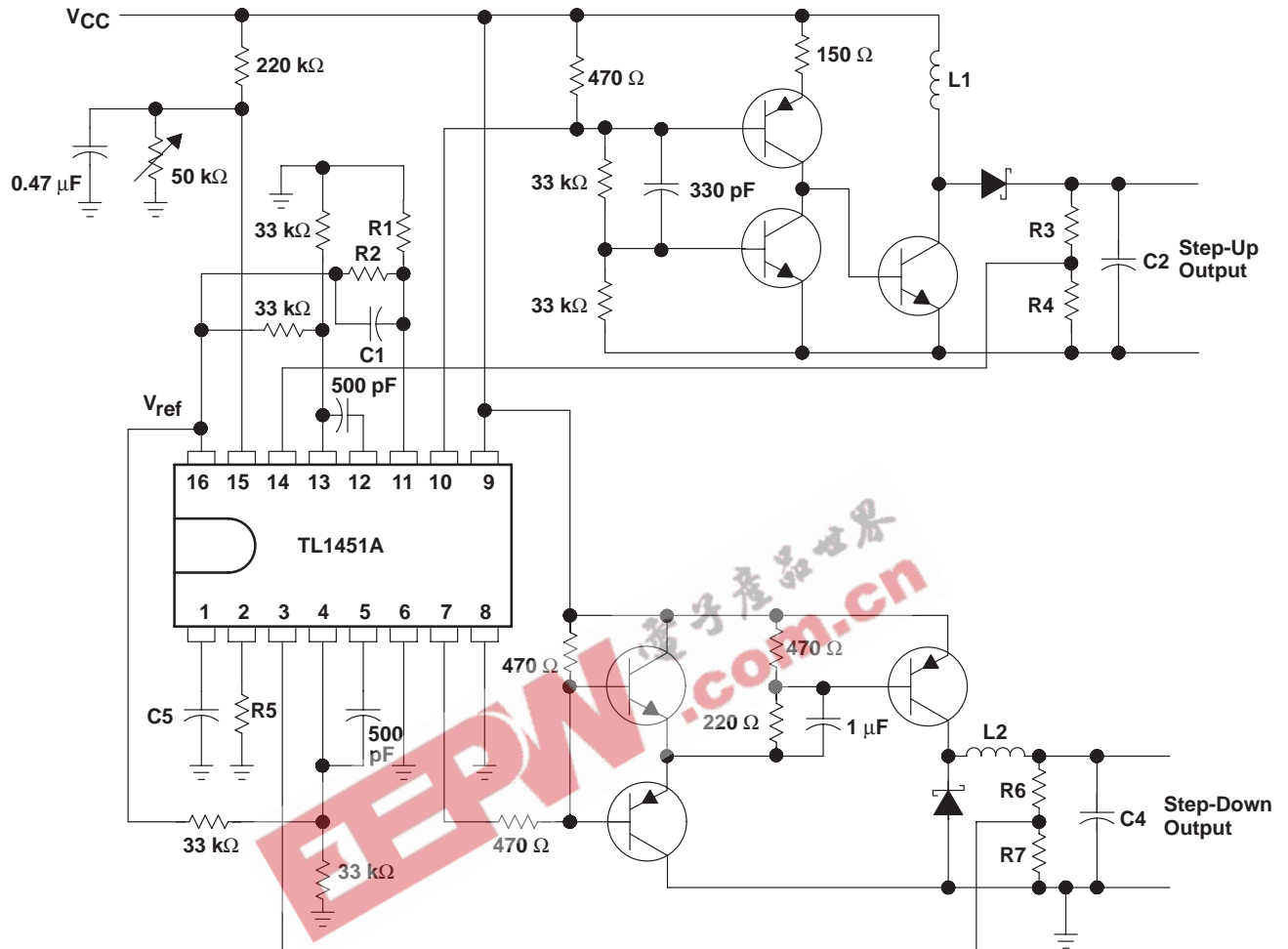

Figure 27

TL1451A DUAL PULSE-WIDTH-MODULATION CONTROL CIRCUITS

SLVS024E – FEBRUARY 1983 – REVISED NOVEMBER 1999

APPLICATION INFORMATION



NOTE A: Values for R1 through R7, C1 through C4, and L1 and L2 depend upon individual application.

Figure 28. High-Speed Dual Switching Regulator

TL1451A DUAL PULSE-WIDTH-MODULATION CONTROL CIRCUITS

SLVS024E – FEBRUARY 1983 – REVISED NOVEMBER 1999

MECHANICAL DATA

D (R-PDSO-G**)

PLASTIC SMALL-OUTLINE PACKAGE

14 PINS SHOWN

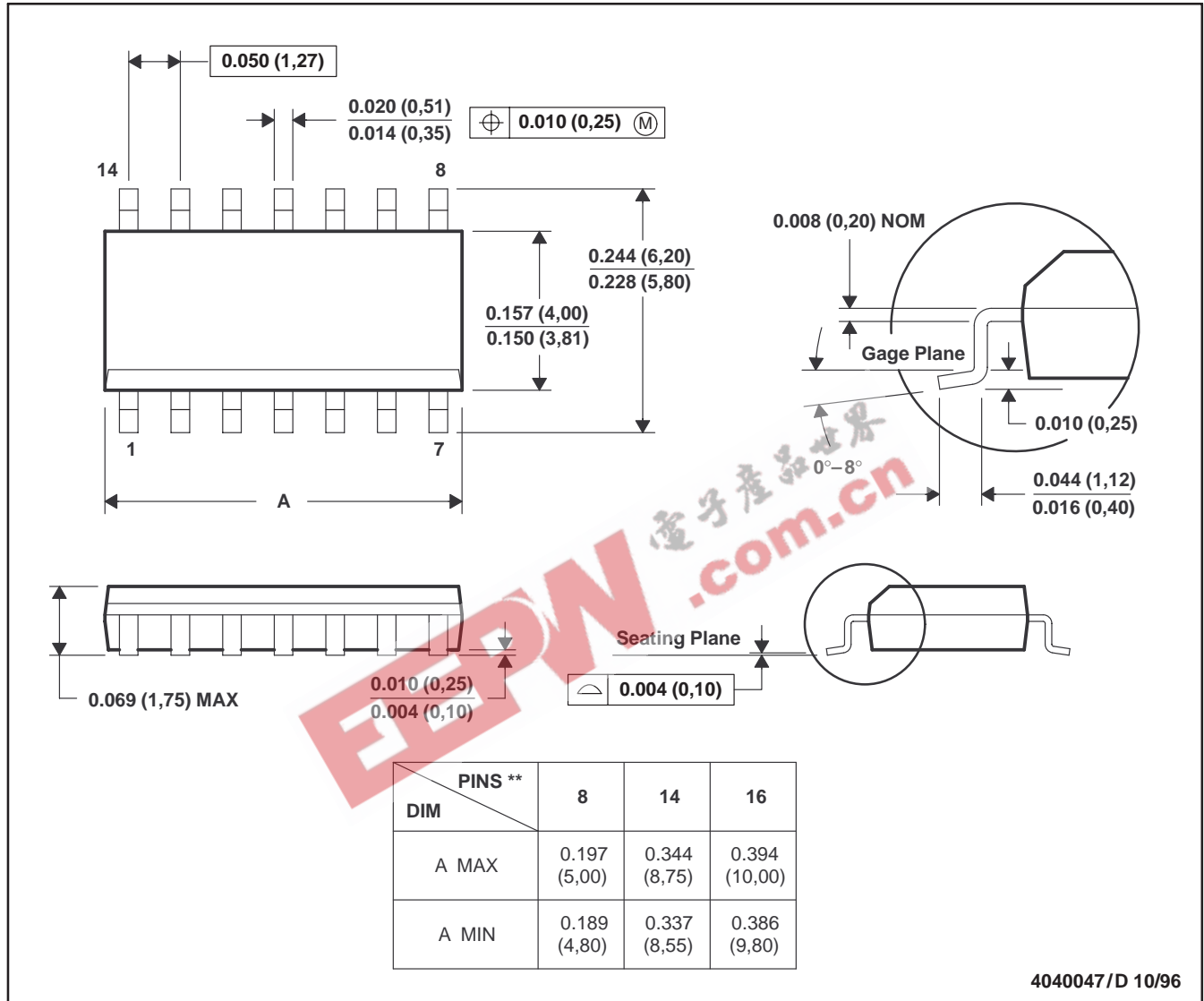

- NOTES: A. All linear dimensions are in inches (millimeters).
 B. This drawing is subject to change without notice.
 C. Body dimensions do not include mold flash or protrusion, not to exceed 0.006 (0,15).
 D. Falls within JEDEC MS-012

TL1451A DUAL PULSE-WIDTH-MODULATION CONTROL CIRCUITS

SLVS024E – FEBRUARY 1983 – REVISED NOVEMBER 1999

MECHANICAL DATA

DB (R-PDSO-G)**

PLASTIC SMALL-OUTLINE PACKAGE

28 PINS SHOWN

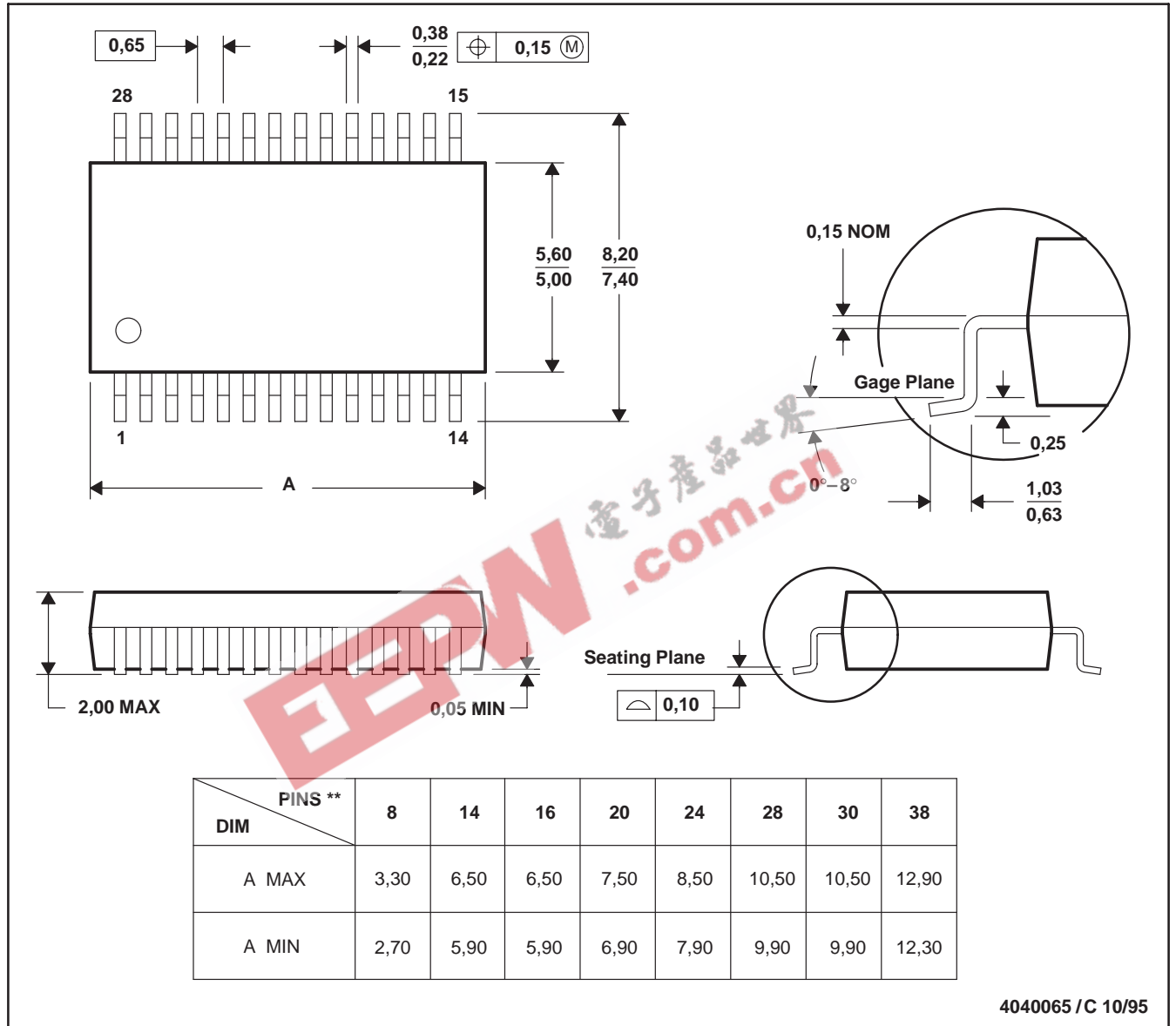

- NOTES: A. All linear dimensions are in millimeters.
 B. This drawing is subject to change without notice.
 C. Body dimensions do not include mold flash or protrusion not to exceed 0,15.
 D. Falls within JEDEC MO-150

TL1451A DUAL PULSE-WIDTH-MODULATION CONTROL CIRCUITS

SLVS024E – FEBRUARY 1983 – REVISED NOVEMBER 1999

MECHANICAL DATA

FK (S-CQCC-N**)

LEADLESS CERAMIC CHIP CARRIER

28 TERMINALS SHOWN

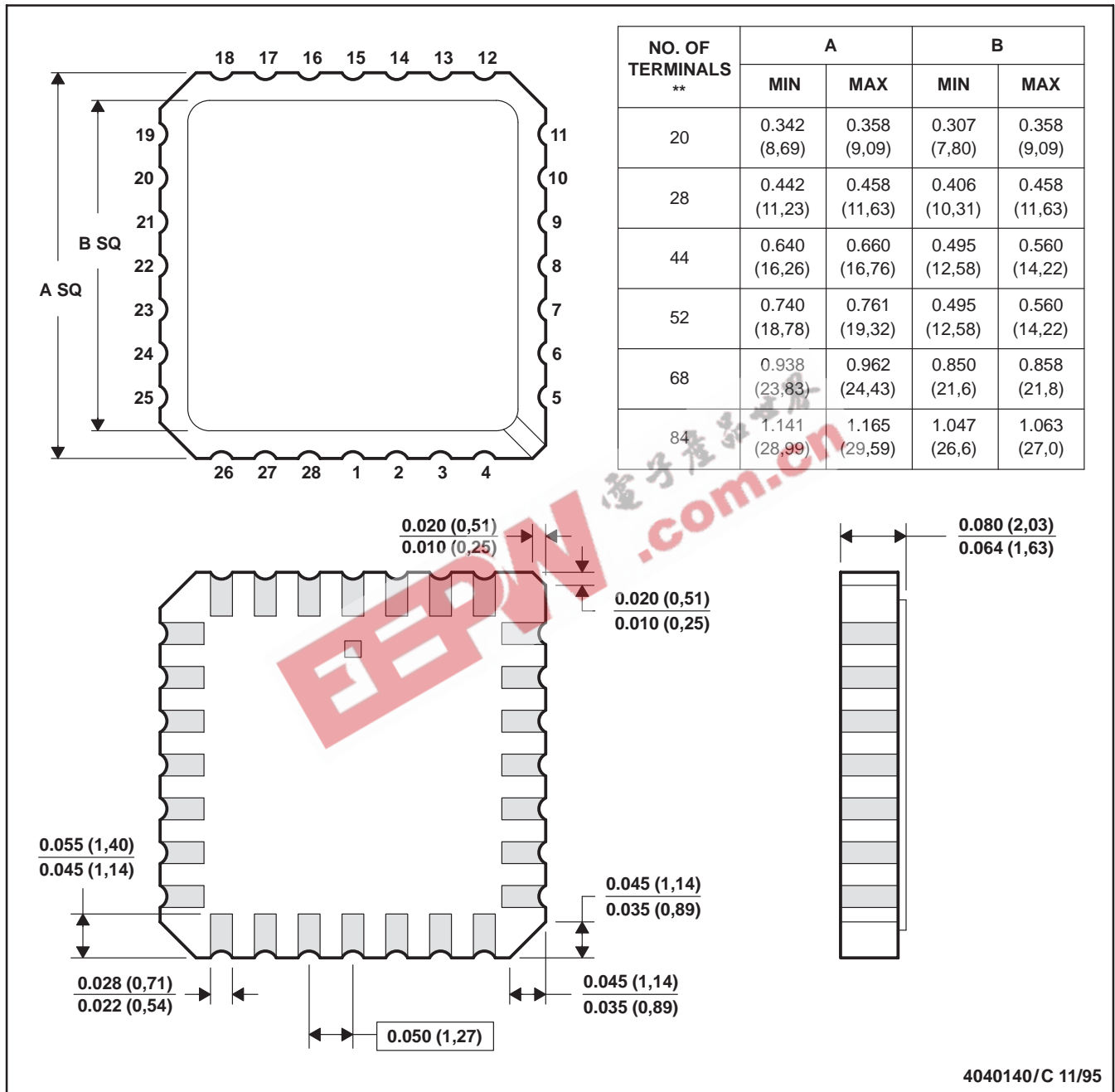

- NOTES:
- All linear dimensions are in inches (millimeters).
 - This drawing is subject to change without notice.
 - This package can be hermetically sealed with a metal lid.
 - The terminals are gold-plated.
 - Falls within JEDEC MS-004

TL1451A DUAL PULSE-WIDTH-MODULATION CONTROL CIRCUITS

SLVS024E – FEBRUARY 1983 – REVISED NOVEMBER 1999

MECHANICAL DATA

J (R-GDIP-T)**

CERAMIC DUAL-IN-LINE

14 LEADS SHOWN

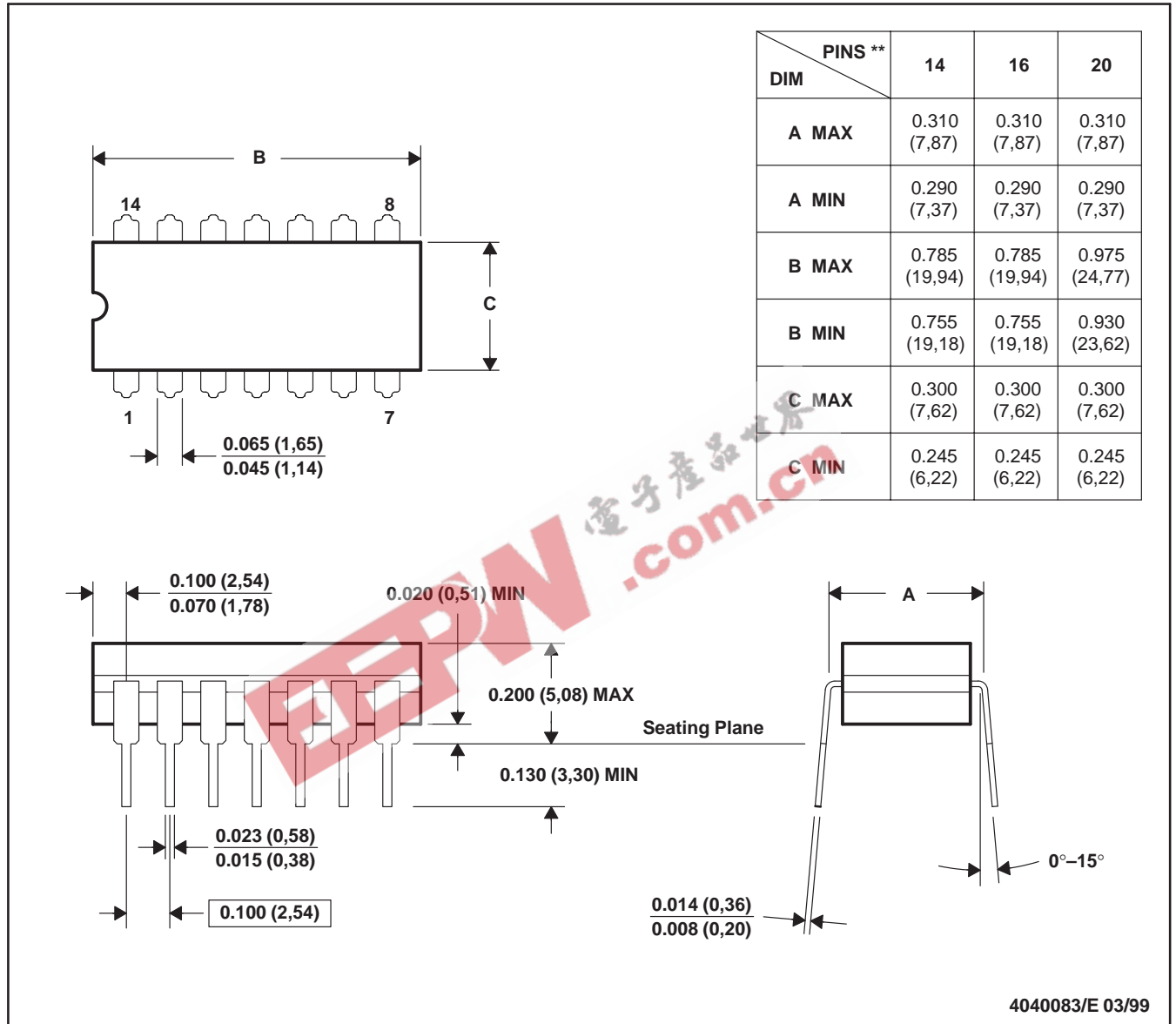

- NOTES:
- A. All linear dimensions are in inches (millimeters).
 - B. This drawing is subject to change without notice.
 - C. This package is hermetically sealed with a ceramic lid using glass frit.
 - D. Index point is provided on cap for terminal identification.
 - E. Falls within MIL STD 1835 GDIP1-T14, GDIP1-T16, and GDIP1-T20

TL1451A DUAL PULSE-WIDTH-MODULATION CONTROL CIRCUITS

SLVS024E – FEBRUARY 1983 – REVISED NOVEMBER 1999

MECHANICAL DATA

N (R-PDIP-T**)

PLASTIC DUAL-IN-LINE PACKAGE

16 PINS SHOWN

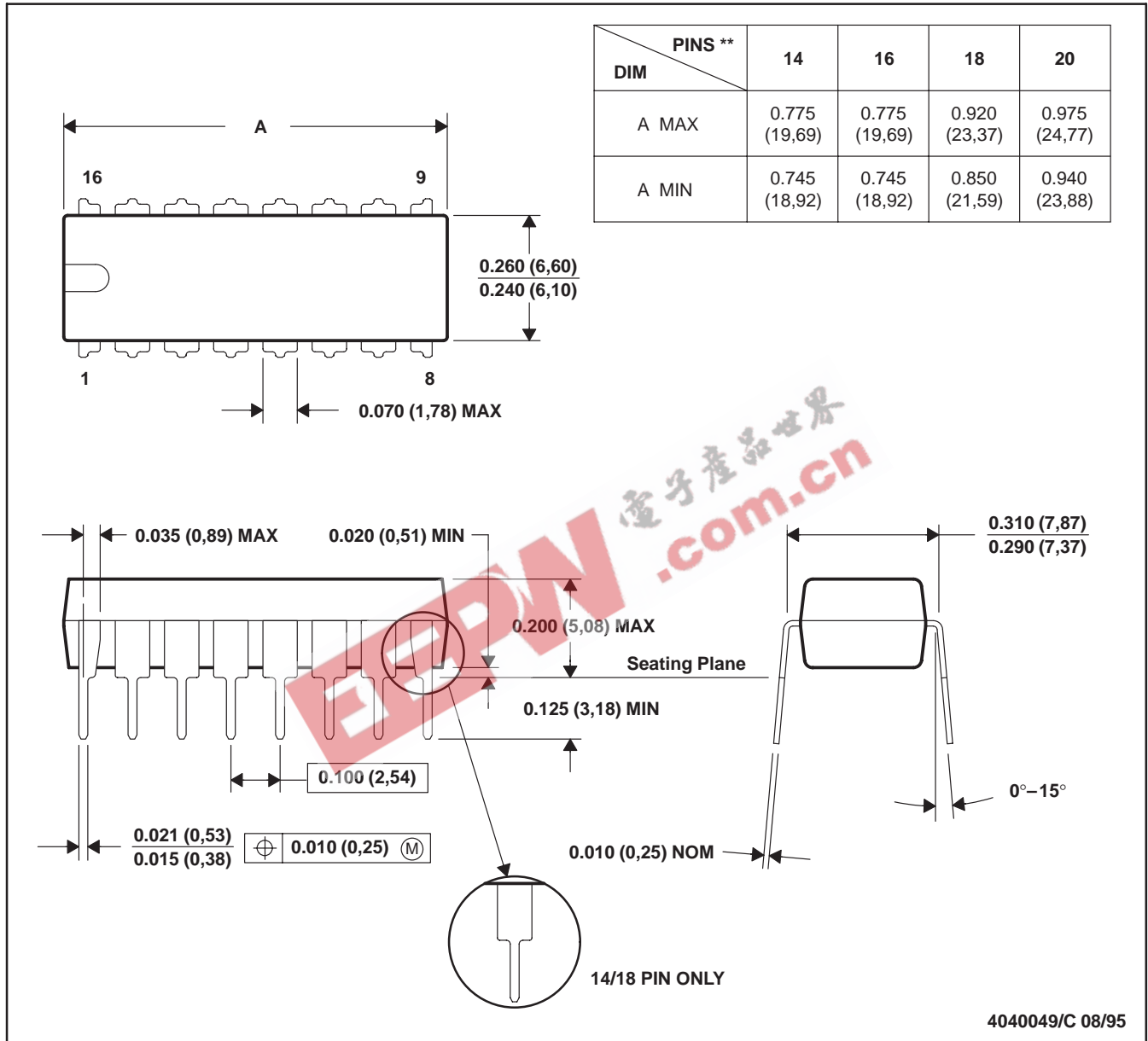

- NOTES: A. All linear dimensions are in inches (millimeters).
 B. This drawing is subject to change without notice.
 C. Falls within JEDEC MS-001 (20-pin package is shorter than MS-001).

TL1451A DUAL PULSE-WIDTH-MODULATION CONTROL CIRCUITS

SLVS024E – FEBRUARY 1983 – REVISED NOVEMBER 1999

MECHANICAL DATA

NS (R-PDSO-G)**

PLASTIC SMALL-OUTLINE PACKAGE

14 PINS SHOWN

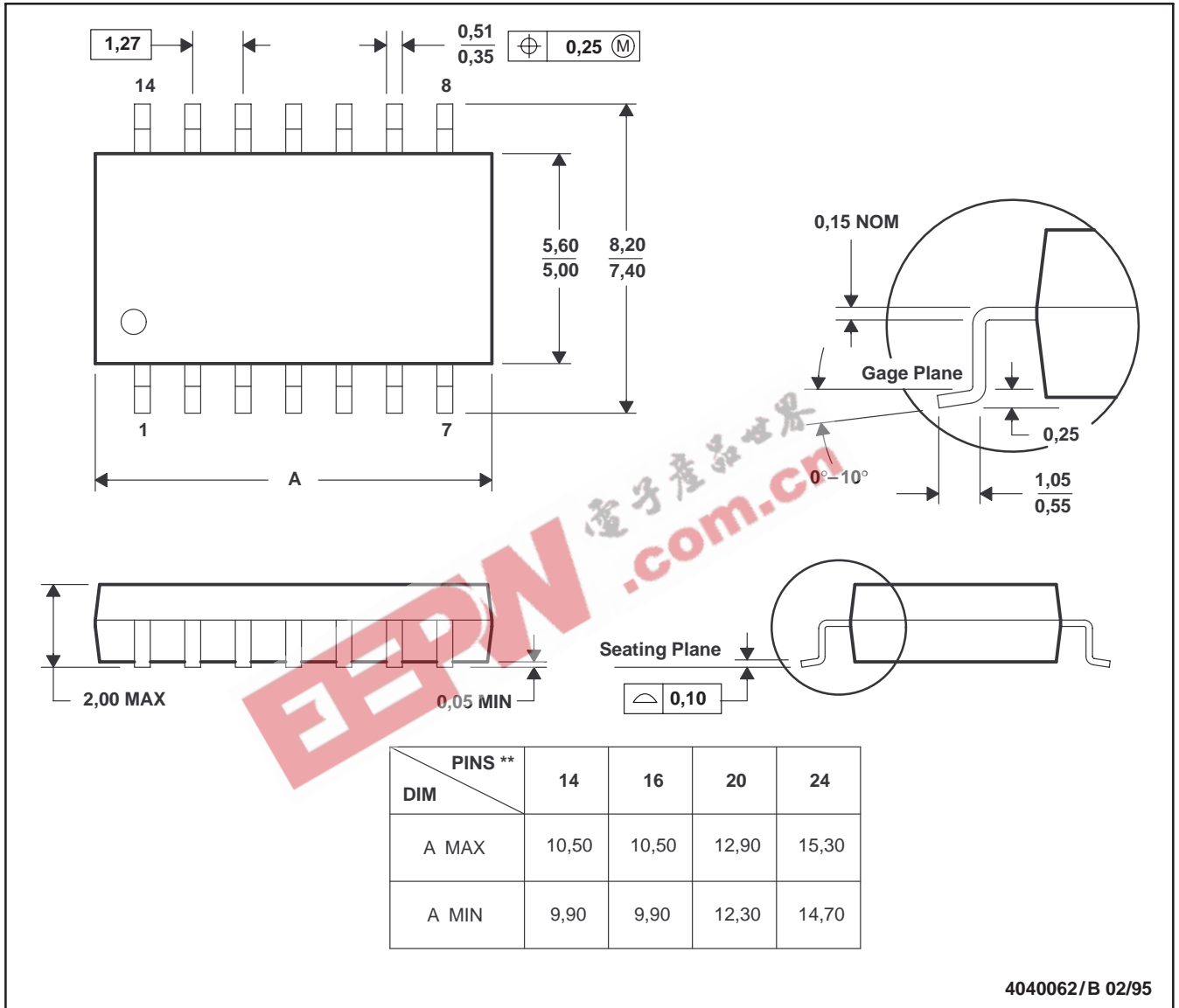

- NOTES: A. All linear dimensions are in millimeters.
 B. This drawing is subject to change without notice.
 C. Body dimensions do not include mold flash or protrusion, not to exceed 0,15.

TL1451A DUAL PULSE-WIDTH-MODULATION CONTROL CIRCUITS

SLVS024E – FEBRUARY 1983 – REVISED NOVEMBER 1999

MECHANICAL DATA

PW (R-PDSO-G**)

PLASTIC SMALL-OUTLINE PACKAGE

14 PINS SHOWN

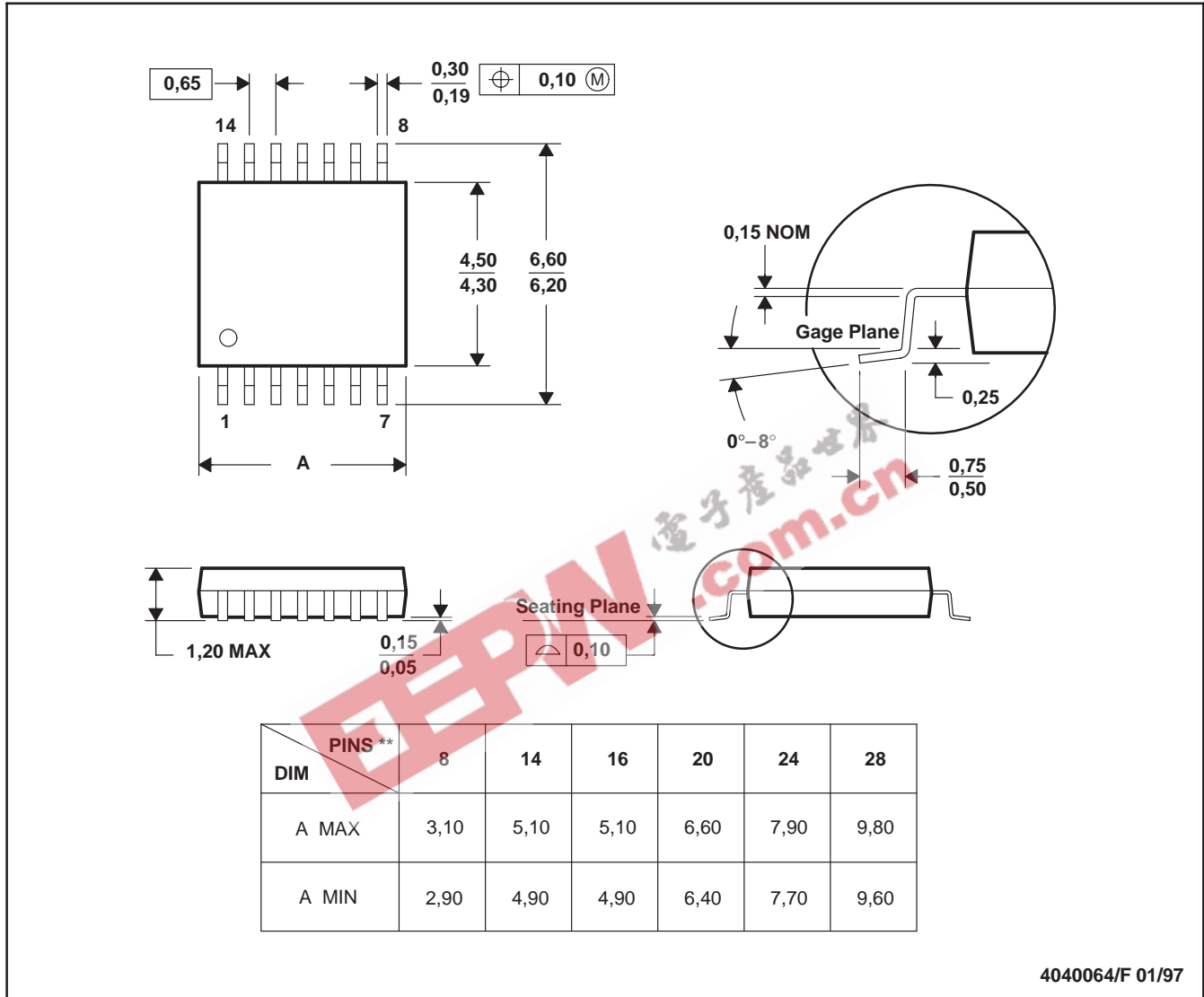

- NOTES: A. All linear dimensions are in millimeters.
 B. This drawing is subject to change without notice.
 C. Body dimensions do not include mold flash or protrusion not to exceed 0,15.
 D. Falls within JEDEC MO-153

IMPORTANT NOTICE

Texas Instruments and its subsidiaries (TI) reserve the right to make changes to their products or to discontinue any product or service without notice, and advise customers to obtain the latest version of relevant information to verify, before placing orders, that information being relied on is current and complete. All products are sold subject to the terms and conditions of sale supplied at the time of order acknowledgement, including those pertaining to warranty, patent infringement, and limitation of liability.

TI warrants performance of its semiconductor products to the specifications applicable at the time of sale in accordance with TI's standard warranty. Testing and other quality control techniques are utilized to the extent TI deems necessary to support this warranty. Specific testing of all parameters of each device is not necessarily performed, except those mandated by government requirements.

CERTAIN APPLICATIONS USING SEMICONDUCTOR PRODUCTS MAY INVOLVE POTENTIAL RISKS OF DEATH, PERSONAL INJURY, OR SEVERE PROPERTY OR ENVIRONMENTAL DAMAGE ("CRITICAL APPLICATIONS"). TI SEMICONDUCTOR PRODUCTS ARE NOT DESIGNED, AUTHORIZED, OR WARRANTED TO BE SUITABLE FOR USE IN LIFE-SUPPORT DEVICES OR SYSTEMS OR OTHER CRITICAL APPLICATIONS. INCLUSION OF TI PRODUCTS IN SUCH APPLICATIONS IS UNDERSTOOD TO BE FULLY AT THE CUSTOMER'S RISK.

In order to minimize risks associated with the customer's applications, adequate design and operating safeguards must be provided by the customer to minimize inherent or procedural hazards.

TI assumes no liability for applications assistance or customer product design. TI does not warrant or represent that any license, either express or implied, is granted under any patent right, copyright, mask work right, or other intellectual property right of TI covering or relating to any combination, machine, or process in which such semiconductor products or services might be or are used. TI's publication of information regarding any third party's products or services does not constitute TI's approval, warranty or endorsement thereof.