

FEATURES

- Simple Voltage Conversion, Including
 - Negative Converter
 - Voltage Doubler
- Wide Operating Range...1.5 V to 10 V
- Requires Only Two External (Noncritical) Capacitors
- No External Diode Over Full Temperature and Voltage Range
- Typical Open-Circuit Voltage Conversion Efficiency...99.9%
- Typical Power Efficiency...98%
- Full Testing at 3 V

APPLICATIONS

- On-Board Negative Supplies
- Data-Acquisition Systems
- Portable Electronics

D, DGK, OR P PACKAGE
(TOP VIEW)

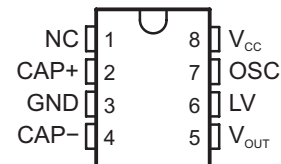

NC – No internal connection

DESCRIPTION/ORDERING INFORMATION

The TL7660 is a CMOS switched-capacitor voltage converter that perform supply-voltage conversions from positive to negative. With only two noncritical external capacitors needed for the charge pump and charge reservoir functions, an input voltage within the range from 1.5 V to 10 V is converted to a complementary negative output voltage of –1.5 V to –10 V. The device can also be connected as a voltage doubler to generate output voltages up to 18.6 V with a 10-V input.

The basic building blocks of the IC include a linear regulator, an RC oscillator, a voltage-level translator, and four power MOS switches. To ensure latch-up-free operation, the circuitry automatically senses the most negative voltage in the device and ensures that the N-channel switch source-substrate junctions are not forward biased. The oscillator frequency runs at a nominal 10 kHz (for V_{CC} = 5 V), but that frequency can be decreased by adding an external capacitor to the oscillator (OSC) terminal or increased by overdriving OSC with an external clock.

For low-voltage operation (V_{IN} < 3.5 V), LV should be tied to GND to bypass the internal series regulator. Above 3.5 V, LV should be left floating to prevent device latchup.

The TL7660C is characterized for operation over a free-air temperature range of –40°C to 85°C. The TL7660I is characterized for operation over a free-air temperature range of –40°C to 125°C.

ORDERING INFORMATION

T _A	PACKAGE ⁽¹⁾		ORDERABLE PART NUMBER	TOP-SIDE MARKING ⁽²⁾
–40°C to 85°C	MSOP/VSSOP – DGK	Reel of 250	TL7660CDGKT	TM ₋
		Reel of 2500	TL7660CDGKR	
	PDIP – P	Tube of 50	TL7660CP	TL7660CP
	SOIC – D	Tube of 75	TL7660CD	7660C
		Reel of 2500	TL7660CDR	
–40°C to 125°C	MSOP/VSSOP – DGK	Reel of 250	TL7660IDGKT	TN ₋
		Reel of 2500	TL7660IDGKR	
	PDIP – P	Tube of 50	TL7660IP	TL7660IP
	SOIC – D	Tube of 75	TL7660ID	7660I
		Reel of 2500	TL7660IDR	

(1) Package drawings, standard packing quantities, thermal data, symbolization, and PCB design guidelines are available at www.ti.com/sc/package.

(2) DGK: The actual top-side marking has one additional character that indicates the assembly/test site.



Please be aware that an important notice concerning availability, standard warranty, and use in critical applications of Texas Instruments semiconductor products and disclaimers thereto appears at the end of this data sheet.

TL7660 CMOS VOLTAGE CONVERTER

SCAS794–JUNE 2006

FUNCTIONAL BLOCK DIAGRAM

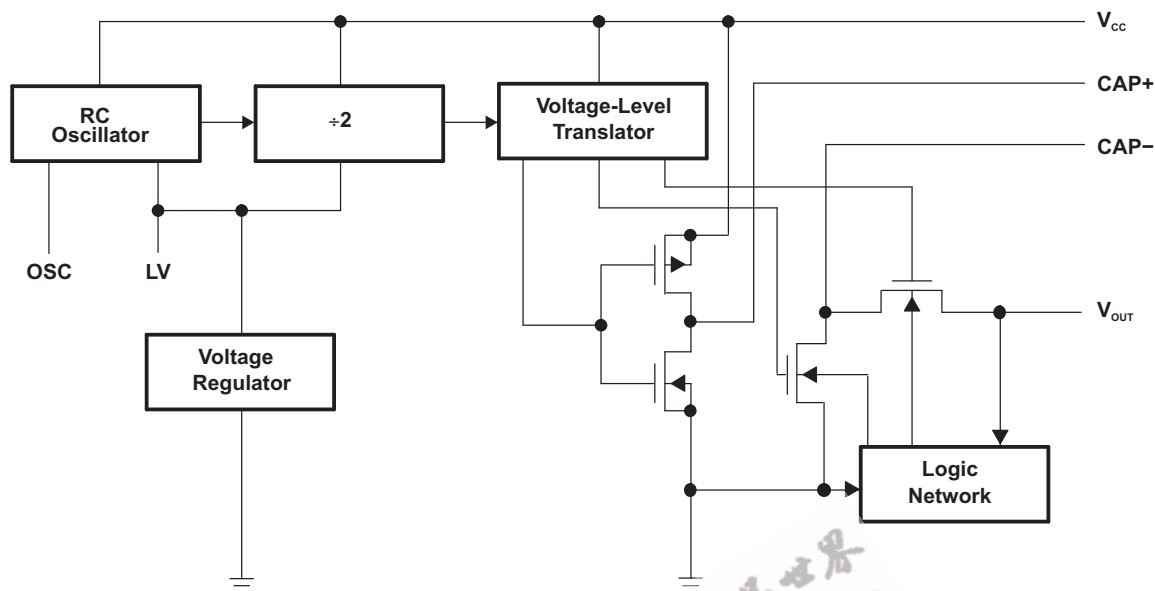

Absolute Maximum Ratings⁽¹⁾

over operating free-air temperature range (unless otherwise noted)

			MIN	MAX	UNIT
V_{CC}	Supply voltage	TL7660		10.5	V
V_I	OSC and LV input voltage range ⁽²⁾	$V_{CC} < 5.5\text{ V}$	-0.3	$V_{CC} + 0.3$	V
		$V_{CC} > 5.5\text{ V}$	$V_{CC} - 5.5$	$V_{CC} + 0.3$	
I_{LV}	Current into LV ⁽²⁾	$V_{CC} > 3.5\text{ V}$		20	μA
t_{OS}	Output short-circuit duration	$V_{SUPPLY} \pm 5.5\text{ V}$		Continuous	
θ_{JA}	Package thermal impedance ⁽³⁾⁽⁴⁾	D package		97	$^{\circ}\text{C/W}$
		DGK package		172	
		P package		85	
T_J	Junction temperature			150	$^{\circ}\text{C}$
T_{stg}	Storage temperature range		-55	150	$^{\circ}\text{C}$

- (1) Stresses beyond those listed under "absolute maximum ratings" may cause permanent damage to the device. These are stress ratings only, and functional operation of the device at these or any other conditions beyond those indicated under "recommended operating conditions" is not implied. Exposure to absolute-maximum-rated conditions for extended periods may affect device reliability.
- (2) Connecting any input terminal to voltages greater than V_{CC} or less than GND may cause destructive latchup. It is recommended that no inputs from sources operating from external supplies be applied prior to power up of the TL7660.
- (3) Maximum power dissipation is a function of $T_J(\text{max})$, θ_{JA} , and T_A . The maximum allowable power dissipation at any allowable ambient temperature is $P_D = (T_J(\text{max}) - T_A)/\theta_{JA}$. Operating at the absolute maximum T_J of 150 $^{\circ}\text{C}$ can affect reliability.
- (4) The package thermal impedance is calculated in accordance with JEDEC 51-7.

Recommended Operating Conditions

			MIN	MAX	UNIT
V_{CC}	Supply voltage	TL7660	1.5	10	V
T_A	Operating free-air temperature	TL7660C	-40	85	$^{\circ}\text{C}$
		TL7660I	-40	125	

Electrical Characteristics

$V_{CC} = 5\text{ V}$, $C_{OSC} = 0$, LV = Open, $T_A = 25^\circ\text{C}$ (unless otherwise noted) (see Figure 1)

PARAMETER	TEST CONDITIONS	$T_A^{(1)}$	MIN	TYP	MAX	UNIT
I_{CC} Supply current	$R_L = \infty$	25°C		45	110	μA
		–40°C to 85°C			120	
		–40°C to 125°C			135	
$V_{CC,LOW}$ Supply voltage range (low)	$R_L = 10\text{ k}\Omega$, LV = GND	Full range	1.5		3.5	V
$V_{CC,HIGH}$ Supply voltage range (high)	$R_L = 10\text{ k}\Omega$, LV Open	Full range	3		10	V
R_{OUT} Output source resistance	$I_O = 20\text{ mA}$	25°C		45	70	Ω
		–40°C to 85°C			85	
		–40°C to 125°C			135	
	$V_{CC} = 2\text{ V}$, $I_O = 3\text{ mA}$, LV = GND	25°C			125	
		–40°C to 85°C			200	
		–40°C to 125°C			250	
f_{OSC} Oscillator frequency		25°C		10		kHz
η_{POWER} Power efficiency	$R_L = 5\text{ k}\Omega$	25°C	96	98		%
		–40°C to 125°C	95			
η_{VOUT} Voltage conversion efficiency	$R_L = \infty$	25°C	99	99.9		%
		–40°C to 125°C	99			
Z_{OSC} Oscillator impedance	$V_{CC} = 2\text{ V}$	25°C		1		$\text{M}\Omega$
	$V_{CC} = 5\text{ V}$			100		$\text{k}\Omega$

(1) Full range is –40°C to 85°C for the TL7660C and –40°C to 125°C for the TL7660I.

Electrical Characteristics

$V_{CC} = 3\text{ V}$, $C_{OSC} = 0$, LV = GND, (unless otherwise noted) (see Figure 1)

PARAMETER	TEST CONDITIONS	T_A	MIN	TYP	MAX	UNIT
I_{CC} Supply current ⁽¹⁾	$R_L = \infty$	25°C		24	50	μA
		–40°C to 85°C			60	
		–40°C to 125°C			75	
R_{OUT} Output source resistance	$I_O = 10\text{ mA}$	25°C		60	100	Ω
		–40°C to 85°C			110	
		–40°C to 125°C			120	
f_{OSC} Oscillator frequency	$C_{OSC} = 0$	25°C	5	9		kHz
		–40°C to 125°C	3			
η_{POWER} Power efficiency	$R_L = 5\text{ k}\Omega$	25°C	96	98		%
		–40°C to 125°C	95			
η_{VOUT} Voltage conversion efficiency	$R_L = \infty$	25°C	99			%
		–40°C to 125°C	99			

(1) Derate linearly above 50°C by 5.5 mW/°C.

TYPICAL CHARACTERISTICS

OSCILLATOR FREQUENCY
vs
OSCILLATOR CAPACITANCE

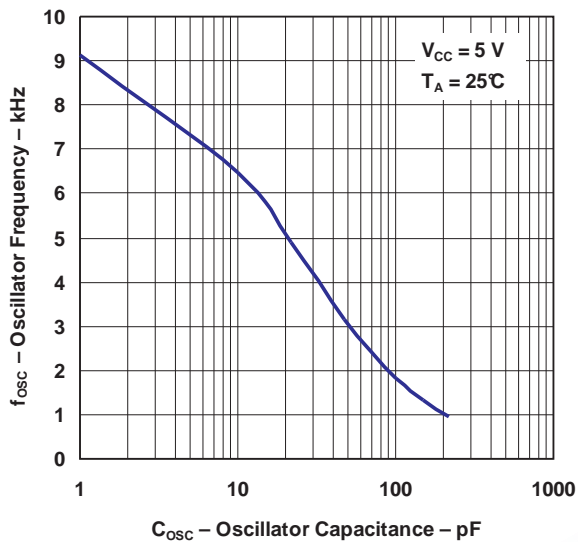

OSCILLATOR FREQUENCY
vs
TEMPERATURE

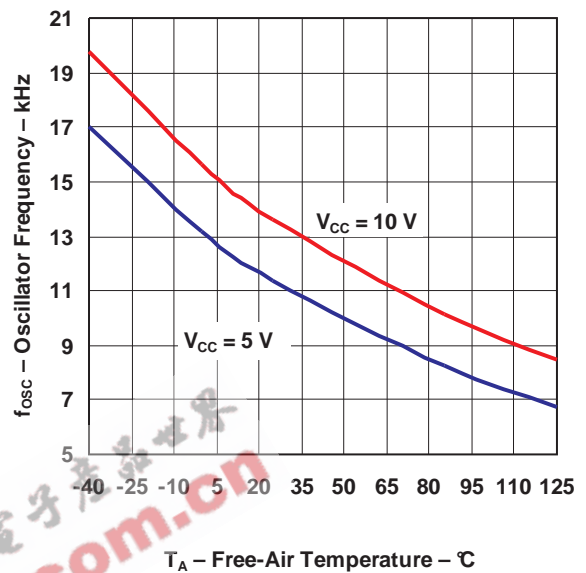

OUTPUT RESISTANCE
vs
TEMPERATURE

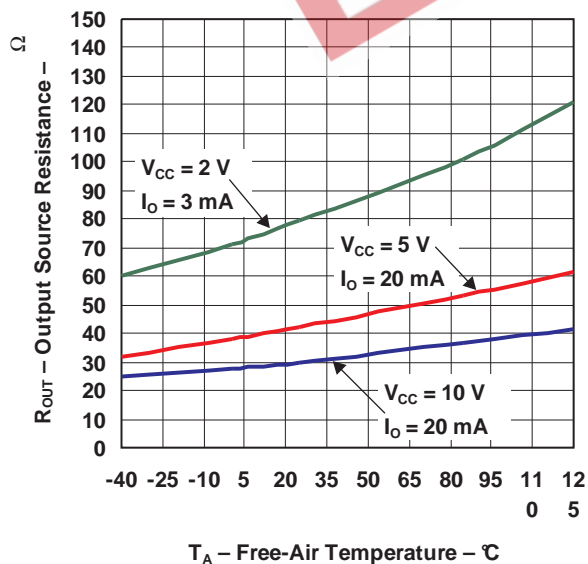

SUPPLY VOLTAGE
vs
TEMPERATURE

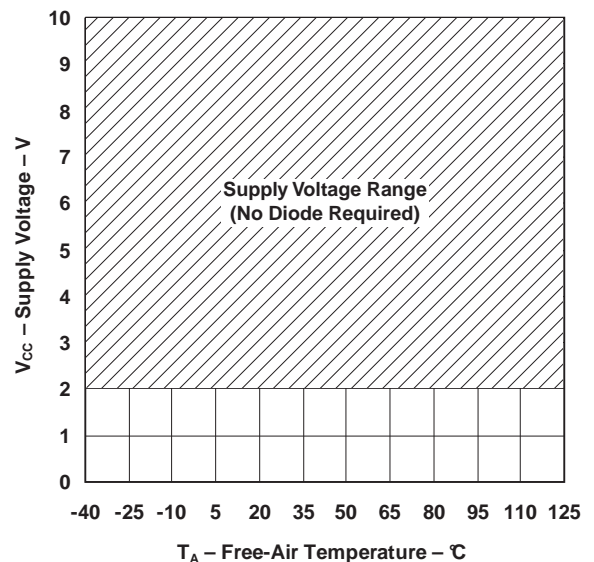

TYPICAL CHARACTERISTICS (continued)

**OUTPUT RESISTANCE
VS
SUPPLY VOLTAGE**

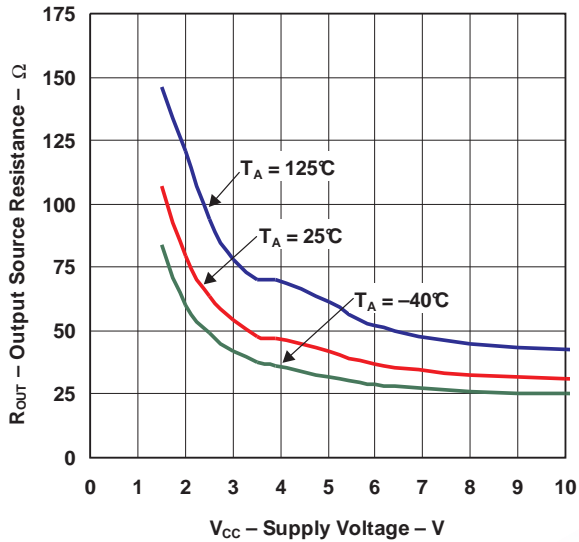

**OUTPUT RESISTANCE
VS
OSCILLATOR FREQUENCY**

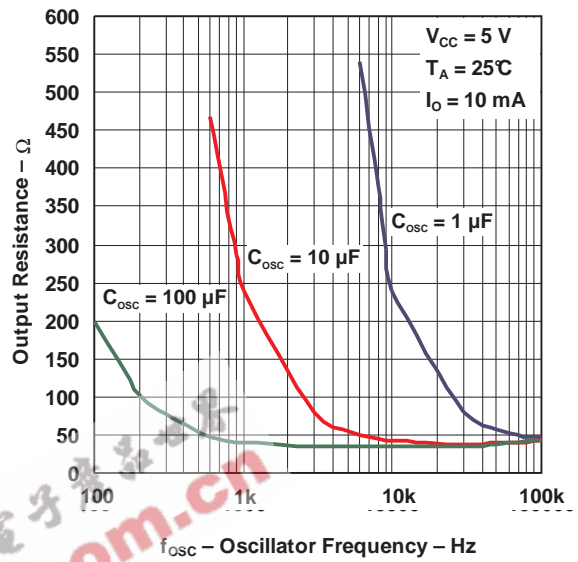

**OUTPUT VOLTAGE
VS
LOAD CURRENT**

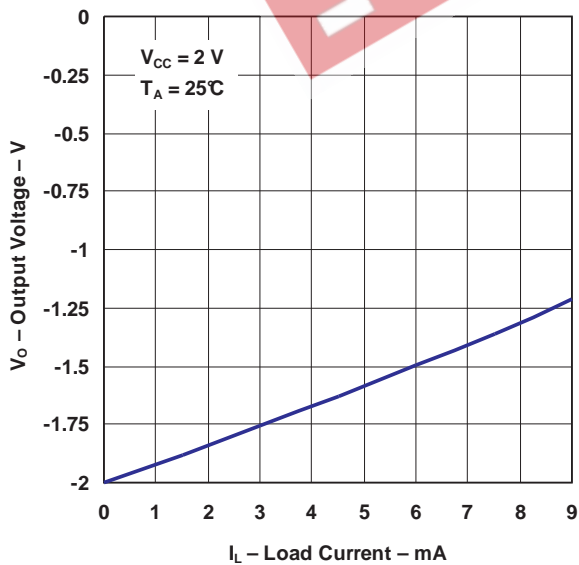

**OUTPUT VOLTAGE
VS
LOAD CURRENT**

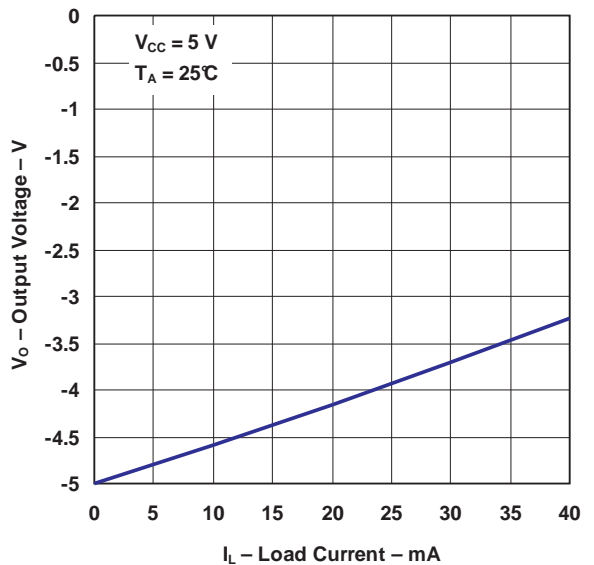

TYPICAL CHARACTERISTICS (continued)

EFFICIENCY AND SUPPLY CURRENT
vs
LOAD CURRENT

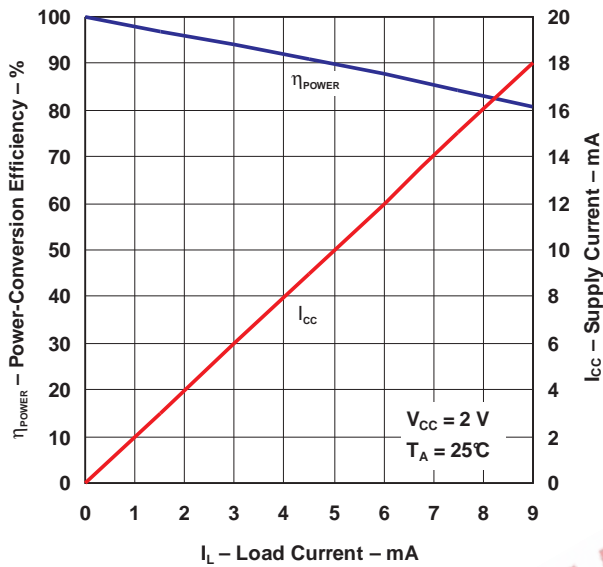

EFFICIENCY AND SUPPLY CURRENT
vs
LOAD CURRENT

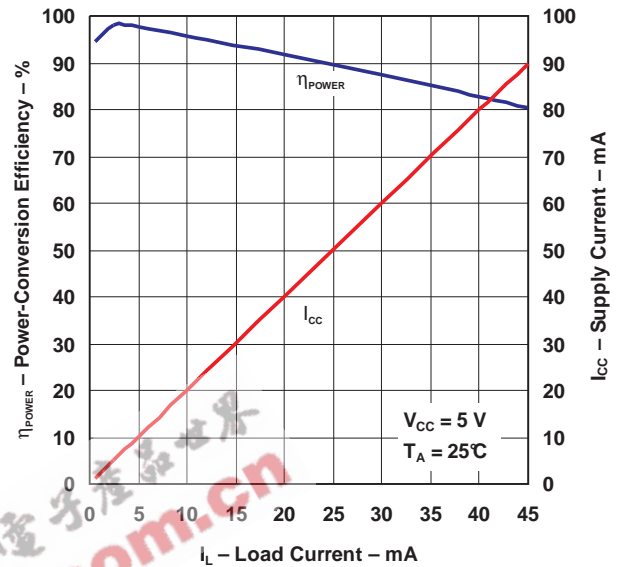

EFFICIENCY
vs
OSCILLATOR FREQUENCY

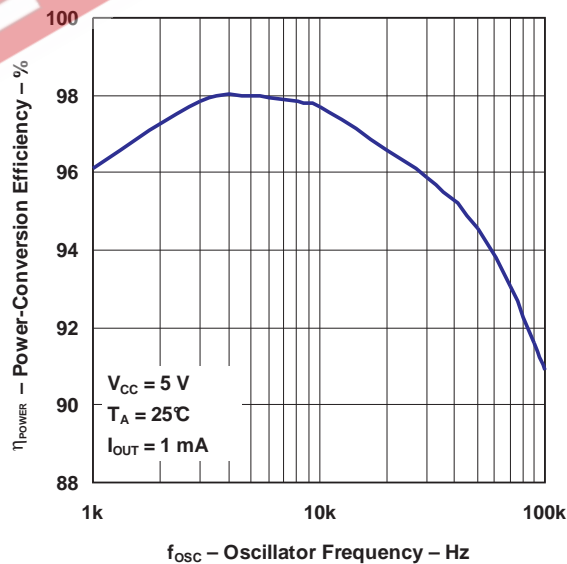

APPLICATION INFORMATION

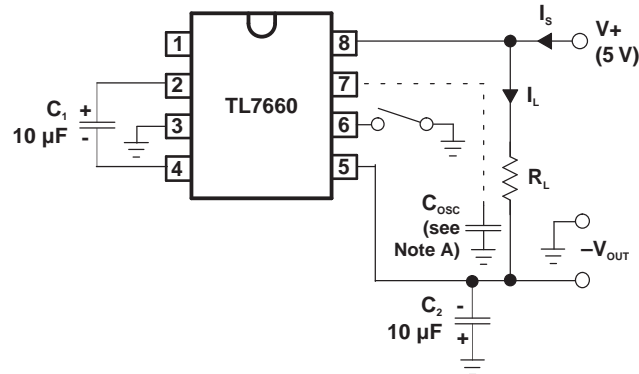

- A. In the circuit, there is no external capacitor applied to terminal 7. However when device is plugged into a test socket, there is usually a very small but finite stray capacitance present on the order of 10 pF.

Figure 1. Test Circuit

The TL7660 contains all the necessary circuitry to complete a negative voltage converter, with the exception of two external capacitors which may be inexpensive 10 µF polarized electrolytic types. The mode of operation of the device may be best understood by considering Figure 2, which shows an idealized negative voltage converter. Capacitor C_1 is charged to a voltage, V_{CC} , for the half cycle when switches S_1 and S_3 are closed. (Note: Switches S_2 and S_4 are open during this half cycle.) During the second half cycle of operation, switches S_2 and S_4 are closed, with S_1 and S_3 open, thereby shifting capacitor C_1 negatively by V_{CC} volts. Charge is then transferred from C_1 to C_2 such that the voltage on C_2 is exactly V_{CC} , assuming ideal switches and no load on C_2 . The TL7660 approaches this ideal situation more closely than existing non-mechanical circuits. In the TL7660, the four switches of Figure 2 are MOS power switches: S_1 is a p-channel device, and S_2 , S_3 , and S_4 are n-channel devices. The main difficulty with this design is that in integrating the switches, the substrates of S_3 and S_4 must always remain reverse biased with respect to their sources, but not so much as to degrade their ON resistances. In addition, at circuit start up and under output short circuit conditions ($V_{OUT} = V_{CC}$), the output voltage must be sensed and the substrate bias adjusted accordingly. Failure to accomplish this results in high power losses and probable device latchup. This problem is eliminated in the TL7660 by a logic network which senses the output voltage (V_{OUT}) together with the level translators and switches the substrates of S_3 and S_4 to the correct level to maintain necessary reverse bias.

The voltage regulator portion of the TL7660 is an integral part of the anti-latchup circuitry; however, its inherent voltage drop can degrade operation at low voltages. Therefore, to improve low-voltage operation, the LV terminal should be connected to GND, disabling the regulator. For supply voltages greater than 3.5 V, the LV terminal must be left open to insure latchup proof operation and prevent device damage.

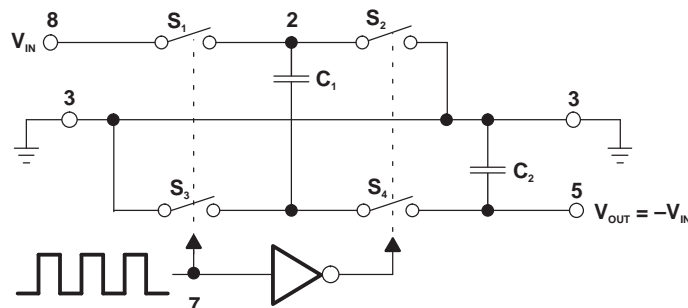

Figure 2. Idealized Negative-Voltage Converter

APPLICATION INFORMATION (continued)

Theoretical Power Efficiency Considerations

In theory, a voltage converter can approach 100% efficiency if certain conditions are met.

- The driver circuitry consumes minimal power.
- The output switches have extremely low ON resistance and virtually no offset.
- The impedances of the pump and reservoir capacitors are negligible at the pump frequency.

The TL7660 approaches these conditions for negative voltage conversion if large values of C_1 and C_2 are used.

Energy is only lost in the transfer of charge between capacitors if a change in voltage occurs. The energy lost is defined by:

$$E = \frac{1}{2} C_1 (V_1^2 - V_2^2)$$

Where V_1 and V_2 are the voltages on C_1 during the pump and transfer cycles. If the impedances of C_1 and C_2 are relatively high at the pump frequency (see [Figure 2](#)) compared to the value of R_L , there is a substantial difference in the voltages V_1 and V_2 . Therefore, it is not only desirable to make C_2 as large as possible to eliminate output voltage ripple but also to employ a correspondingly large value for C_1 in order to achieve maximum efficiency of operation.

Do's and Don'ts

- Do not exceed maximum supply voltages.
- Do not connect LV terminal to GND for supply voltages greater than 3.5 V.
- Do not short circuit the output to V_{CC} supply for supply voltages above 5.5 V for extended periods, however, transient conditions including start-up are okay.
- When using polarized capacitors, the positive terminal of C_1 must be connected to terminal 2 of the TL7660, and the positive terminal of C_2 must be connected to GND.
- If the voltage supply driving the TL7660 has a large source impedance ($25 \Omega - 30 \Omega$), then a 2.2- μ F capacitor from terminal 8 to ground may be required to limit rate of rise of input voltage to less than 2V/ μ s.
- Ensure that the output (terminal 5) does not go more positive than GND (terminal 3). Device latch up occurs under these conditions. A 1N914 or similar diode placed in parallel with C_2 prevents the device from latching up under these conditions (anode to terminal 5, cathode to terminal 3).

APPLICATION INFORMATION (continued)

Typical Applications

Simple Negative Voltage Converter

The majority of applications will undoubtedly utilize the TL7660 for generation of negative supply voltages. Figure 3 shows typical connections to provide a negative supply negative (GND) for supply voltages below 3.5 V.

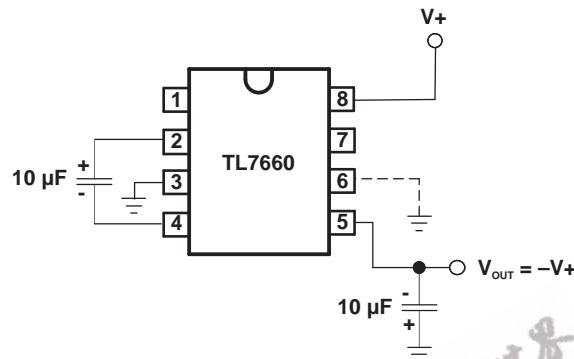

Figure 3. Simple Negative-Voltage Converter

The output characteristics of the circuit in Figure 3 can be approximated by an ideal voltage source in series with a resistance. The voltage source has a value of $-V_{CC}$. The output impedance (R_O) is a function of the ON resistance of the internal MOS switches (shown in Figure 2), the switching frequency, the value of C_1 and C_2 , and the ESR (equivalent series resistance) of C_1 and C_2 . A good first order approximation for R_O is:

$$R_O \approx 2(R_{SW1} + R_{SW3} + ESR_{C1}) + 2(R_{SW2} + R_{SW4} + ESR_{C1})$$

$$R_O \approx 2(R_{SW1} + R_{SW3} + ESR_{C1}) + 1/f_{PUMP}C_1 + ESR_{C2}$$

Where $f_{PUMP} = f_{OSC}/2$, R_{SWX} = MOSFET switch resistance.

Combining the four R_{SWX} terms as R_{SW} , we see that:

$$R_O \approx 2(R_{SW}) + 1/f_{PUMP}C_1 + 4(ESR_{C1}) + ESR_{C2}$$

R_{SW} , the total switch resistance, is a function of supply voltage and temperature (See the Output Source Resistance graphs). Careful selection of C_1 and C_2 reduces the remaining terms, minimizing the output impedance. High value capacitors reduce the $1/f_{PUMP}C_1$ component, and low ESR capacitors lower the ESR term. Increasing the oscillator frequency reduces the $1/f_{PUMP}C_1$ term but may have the side effect of a net increase in output impedance when $C_1 > 10 \mu F$ and there is no longer enough time to fully charge the capacitors every cycle. In a typical application where $f_{OSC} = 10 \text{ kHz}$ and $C = C_1 = C_2 = 10 \mu F$:

$$R_O \approx 2(23) + 1/(5 \times 10^3)(10^{-5}) + 4(ESR_{C1}) + ESR_{C2}$$

$$R_O \approx 46 + 20 + 5(ESR_C)$$

Because the ESRs of the capacitors are reflected in the output impedance multiplied by a factor of 5, a high value could potentially swamp out a low $1/f_{PUMP}C_1$ term, rendering an increase in switching frequency or filter capacitance ineffective. Typical electrolytic capacitors may have ESRs as high as 10 Ω .

APPLICATION INFORMATION (continued)

Output Ripple

ESR also affects the ripple voltage seen at the output. The total ripple is determined by two voltages, A and B, as shown in Figure 4. Segment A is the voltage drop across the ESR of C_2 at the instant it goes from being charged by C_1 (current flow into C_2) to being discharged through the load (current flowing out of C_2). The magnitude of this current change is $2 \times I_{OUT}$, hence the total drop is $2 \times I_{OUT} \times eSR_{C2}$ V. Segment B is the voltage change across C_2 during time t_2 , the half of the cycle when C_2 supplies current to the load. The drop at B is $I_{OUT} \times t_2/C_2$ V. The peak-to-peak ripple voltage is the sum of these voltage drops:

$$V_{RIPPLE} \approx (1/(2f_{PUMP}C_2) + 2(ESR_{C2})) \times I_{OUT}$$

Again, a low ESR capacitor results in a higher performance output.

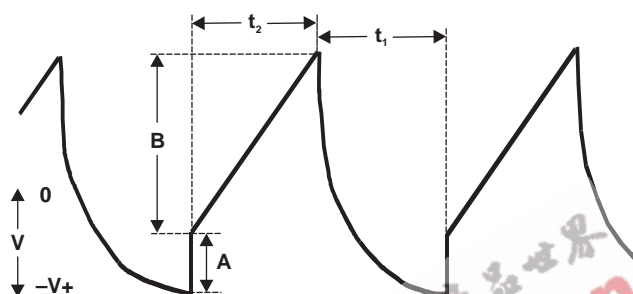

Figure 4. Output Ripple

Paralleling Devices

Any number of TL7660 voltage converters may be paralleled to reduce output resistance (see Figure 5). The reservoir capacitor, C_2 , serves all devices, while each device requires its own pump capacitor, C_1 . The resultant output resistance would be approximately:

$$R_{OUT} = R_{OUT} \text{ (of TL7660)}/n \text{ (number of devices)}$$

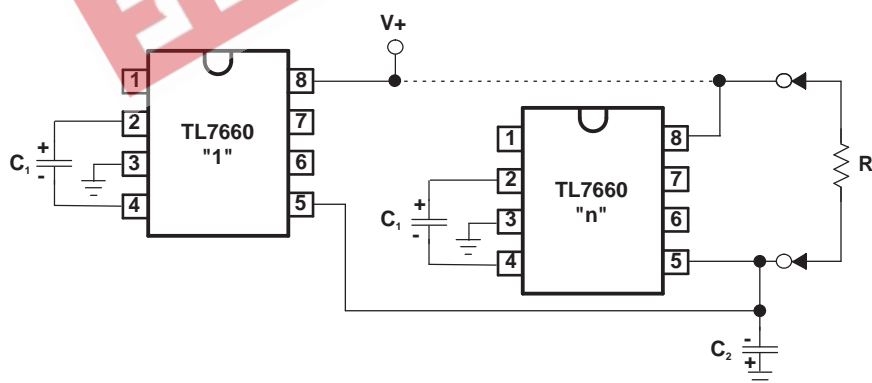

Figure 5. Paralleling Devices

APPLICATION INFORMATION (continued)

Cascading Devices

The TL7660 may be cascaded as shown to produce larger negative multiplication of the initial supply voltage (see Figure 6). However, due to the finite efficiency of each device, the practical limit is 10 devices for light loads. The output voltage is defined by:

$$V_{OUT} = -n (V_{IN})$$

Where n is an integer representing the number of devices cascaded. The resulting output resistance would be approximately the weighted sum of the individual TL7660 R_{OUT} values.

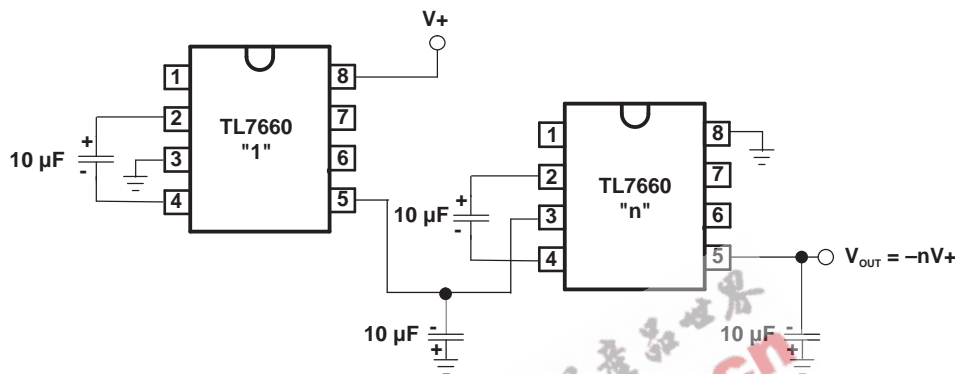

Figure 6. Cascading Devices for Increased Output Voltage

Changing the TL7660 Oscillator Frequency

It may be desirable in some applications, due to noise or other considerations, to increase the oscillator frequency. This is achieved by overdriving the oscillator from an external clock, as shown in Figure 7. To prevent possible device latchup, a 1-kΩ resistor must be used in series with the clock output. When the external clock frequency is generated using TTL logic, the addition of a 10-kΩ pullup resistor to V_{CC} supply is required. Note that the pump frequency with external clocking, as with internal clocking, will be 1/2 of the clock frequency. Output transitions occur on the positive-going edge of the clock.

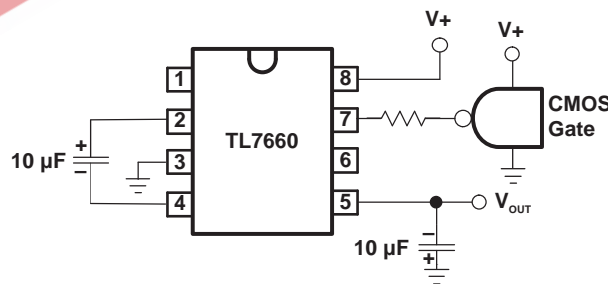

Figure 7. External Clocking

APPLICATION INFORMATION (continued)

It is also possible to increase the conversion efficiency of the TL7660 at low load levels by lowering the oscillator frequency (see Figure 8). This reduces the switching losses. However, lowering the oscillator frequency causes an undesirable increase in the impedance of the pump (C_1) and reservoir (C_2) capacitors; this is overcome by increasing the values of C_1 and C_2 by the same factor that the frequency has been reduced. For example, the addition of a 100-pF capacitor between terminal 7 (OSC) and V_{CC} lowers the oscillator frequency to 1 kHz from its nominal frequency of 10 kHz (a multiple of 10), and thereby necessitate a corresponding increase in the value of C_1 and C_2 (from 10 μ F to 100 μ F).

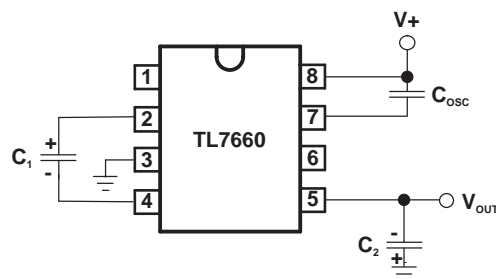

Figure 8. Lowering Oscillator Frequency

Positive Voltage Doubling

The TL7660 may be used to achieve positive voltage doubling using the circuit shown in Figure 9. In this application, the pump inverter switches of the TL7660 are used to charge C_1 to a voltage level of $V_{CC} - V_F$ (where V_{CC} is the supply voltage and V_F is the forward voltage drop of diode D_1). On the transfer cycle, the voltage on C_1 plus the supply voltage (V_{CC}) is applied through diode D_2 to capacitor C_2 . The voltage thus created on C_2 becomes $(2V_{CC}) - (2V_F)$ or twice the supply voltage minus the combined forward voltage drops of diodes D_1 and D_2 .

The source impedance of the output (V_{OUT}) depends on the output current.

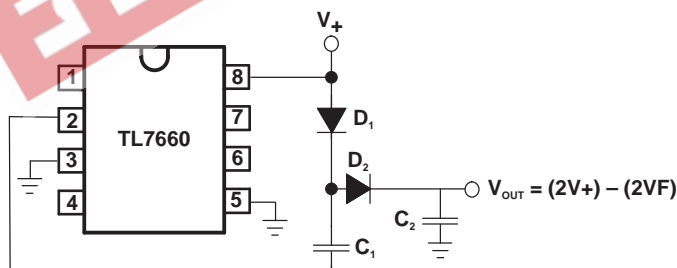

Figure 9. Positive-Voltage Doubler

APPLICATION INFORMATION (continued)

Combined Negative Voltage Conversion and Positive Supply Doubling

Figure 10 combines the functions shown in Figure 3 and Figure 9 to provide negative voltage conversion and positive voltage doubling simultaneously. This approach would be, for example, suitable for generating +9 V and –5 V from an existing 5-V supply. In this instance, capacitors C_1 and C_3 perform the pump and reservoir functions, respectively, for the generation of the negative voltage, while capacitors C_2 and C_4 are pump and reservoir, respectively, for the doubled positive voltage. There is a penalty in this configuration that combines both functions, however, in that the source impedances of the generated supplies are somewhat higher, due to the finite impedance of the common charge pump driver at terminal 2 of the device.

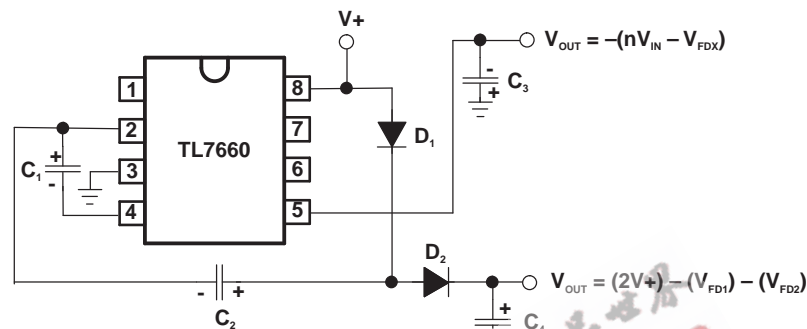

Figure 10. Combined Negative-Voltage Converter and Positive-Voltage Doubler

Voltage Splitting

The bidirectional characteristics can also be used to split a higher supply in half (see Figure 11). The combined load is evenly shared between the two sides. Because the switches share the load in parallel, the output impedance is much lower than in the standard circuits, and higher currents can be drawn from the device. By using this circuit and then the circuit of Figure 6, 15 V can be converted (via 7.5 V, and –7.5 V) to a nominal –15 V, although with rather high series output resistance (~250 Ω).

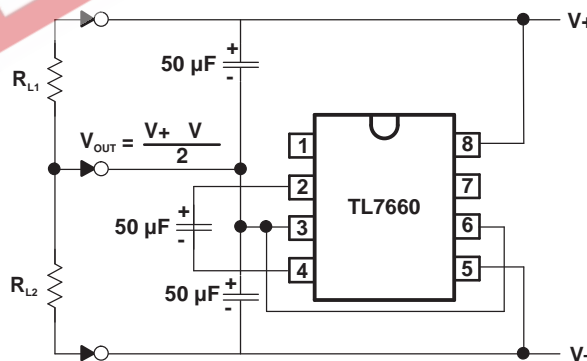

Figure 11. Splitting a Supply in Half

PACKAGING INFORMATION

Orderable Device	Status ⁽¹⁾	Package Type	Package Drawing	Pins	Package Qty	Eco Plan ⁽²⁾	Lead/Ball Finish	MSL Peak Temp ⁽³⁾
TL7660CD	ACTIVE	SOIC	D	8	75	Green (RoHS & no Sb/Br)	CU NIPDAU	Level-1-260C-UNLIM
TL7660CDG4	ACTIVE	SOIC	D	8	75	Green (RoHS & no Sb/Br)	CU NIPDAU	Level-1-260C-UNLIM
TL7660CDGKR	ACTIVE	MSOP	DGK	8	2500	Green (RoHS & no Sb/Br)	CU NIPDAU	Level-1-260C-UNLIM
TL7660CDGKRG4	ACTIVE	MSOP	DGK	8	2500	Green (RoHS & no Sb/Br)	CU NIPDAU	Level-1-260C-UNLIM
TL7660CDGKT	ACTIVE	MSOP	DGK	8	250	Green (RoHS & no Sb/Br)	CU NIPDAU	Level-1-260C-UNLIM
TL7660CDGKTG4	ACTIVE	MSOP	DGK	8	250	Green (RoHS & no Sb/Br)	CU NIPDAU	Level-1-260C-UNLIM
TL7660CDR	ACTIVE	SOIC	D	8	2500	Green (RoHS & no Sb/Br)	CU NIPDAU	Level-1-260C-UNLIM
TL7660CDRG4	ACTIVE	SOIC	D	8	2500	Green (RoHS & no Sb/Br)	CU NIPDAU	Level-1-260C-UNLIM
TL7660CP	ACTIVE	PDIP	P	8	50	Pb-Free (RoHS)	CU NIPDAU	N / A for Pkg Type
TL7660CPE4	ACTIVE	PDIP	P	8	50	Pb-Free (RoHS)	CU NIPDAU	N / A for Pkg Type
TL7660ID	ACTIVE	SOIC	D	8	75	Green (RoHS & no Sb/Br)	CU NIPDAU	Level-1-260C-UNLIM
TL7660IDG4	ACTIVE	SOIC	D	8	75	Green (RoHS & no Sb/Br)	CU NIPDAU	Level-1-260C-UNLIM
TL7660IDGKR	ACTIVE	MSOP	DGK	8	2500	Green (RoHS & no Sb/Br)	CU NIPDAU	Level-1-260C-UNLIM
TL7660IDGKRG4	ACTIVE	MSOP	DGK	8	2500	Green (RoHS & no Sb/Br)	CU NIPDAU	Level-1-260C-UNLIM
TL7660IDGKT	ACTIVE	MSOP	DGK	8	250	Green (RoHS & no Sb/Br)	CU NIPDAU	Level-1-260C-UNLIM
TL7660IDGKTG4	ACTIVE	MSOP	DGK	8	250	Green (RoHS & no Sb/Br)	CU NIPDAU	Level-1-260C-UNLIM
TL7660IDR	ACTIVE	SOIC	D	8	2500	Green (RoHS & no Sb/Br)	CU NIPDAU	Level-1-260C-UNLIM
TL7660IDRG4	ACTIVE	SOIC	D	8	2500	Green (RoHS & no Sb/Br)	CU NIPDAU	Level-1-260C-UNLIM
TL7660IP	ACTIVE	PDIP	P	8	50	Pb-Free (RoHS)	CU NIPDAU	N / A for Pkg Type
TL7660IPE4	ACTIVE	PDIP	P	8	50	Pb-Free (RoHS)	CU NIPDAU	N / A for Pkg Type

⁽¹⁾ The marketing status values are defined as follows:

ACTIVE: Product device recommended for new designs.

LIFEBUY: TI has announced that the device will be discontinued, and a lifetime-buy period is in effect.

NRND: Not recommended for new designs. Device is in production to support existing customers, but TI does not recommend using this part in a new design.

PREVIEW: Device has been announced but is not in production. Samples may or may not be available.

OBSOLETE: TI has discontinued the production of the device.

⁽²⁾ Eco Plan - The planned eco-friendly classification: Pb-Free (RoHS), Pb-Free (RoHS Exempt), or Green (RoHS & no Sb/Br) - please check <http://www.ti.com/productcontent> for the latest availability information and additional product content details.

TBD: The Pb-Free/Green conversion plan has not been defined.

Pb-Free (RoHS): TI's terms "Lead-Free" or "Pb-Free" mean semiconductor products that are compatible with the current RoHS requirements for all 6 substances, including the requirement that lead not exceed 0.1% by weight in homogeneous materials. Where designed to be soldered at high temperatures, TI Pb-Free products are suitable for use in specified lead-free processes.

Pb-Free (RoHS Exempt): This component has a RoHS exemption for either 1) lead-based flip-chip solder bumps used between the die and package, or 2) lead-based die adhesive used between the die and leadframe. The component is otherwise considered Pb-Free (RoHS compatible) as defined above.

Green (RoHS & no Sb/Br): TI defines "Green" to mean Pb-Free (RoHS compatible), and free of Bromine (Br) and Antimony (Sb) based flame retardants (Br or Sb do not exceed 0.1% by weight in homogeneous material)

⁽³⁾ MSL, Peak Temp. -- The Moisture Sensitivity Level rating according to the JEDEC industry standard classifications, and peak solder temperature.

Important Information and Disclaimer:The information provided on this page represents TI's knowledge and belief as of the date that it is provided. TI bases its knowledge and belief on information provided by third parties, and makes no representation or warranty as to the accuracy of such information. Efforts are underway to better integrate information from third parties. TI has taken and continues to take reasonable steps to provide representative and accurate information but may not have conducted destructive testing or chemical analysis on incoming materials and chemicals. TI and TI suppliers consider certain information to be proprietary, and thus CAS numbers and other limited information may not be available for release.

In no event shall TI's liability arising out of such information exceed the total purchase price of the TI part(s) at issue in this document sold by TI to Customer on an annual basis.

EEPW 电子产品世界
.com.cn

MECHANICAL DATA

MPDI001A – JANUARY 1995 – REVISED JUNE 1999

P (R-PDIP-T8)

PLASTIC DUAL-IN-LINE



- NOTES: A. All linear dimensions are in inches (millimeters).
 B. This drawing is subject to change without notice.
 C. Falls within JEDEC MS-001

For the latest package information, go to http://www.ti.com/sc/docs/package/pkg_info.htm



POST OFFICE BOX 655303 • DALLAS, TEXAS 75265

MECHANICAL DATA

D (R-PDSO-G8)

PLASTIC SMALL-OUTLINE PACKAGE

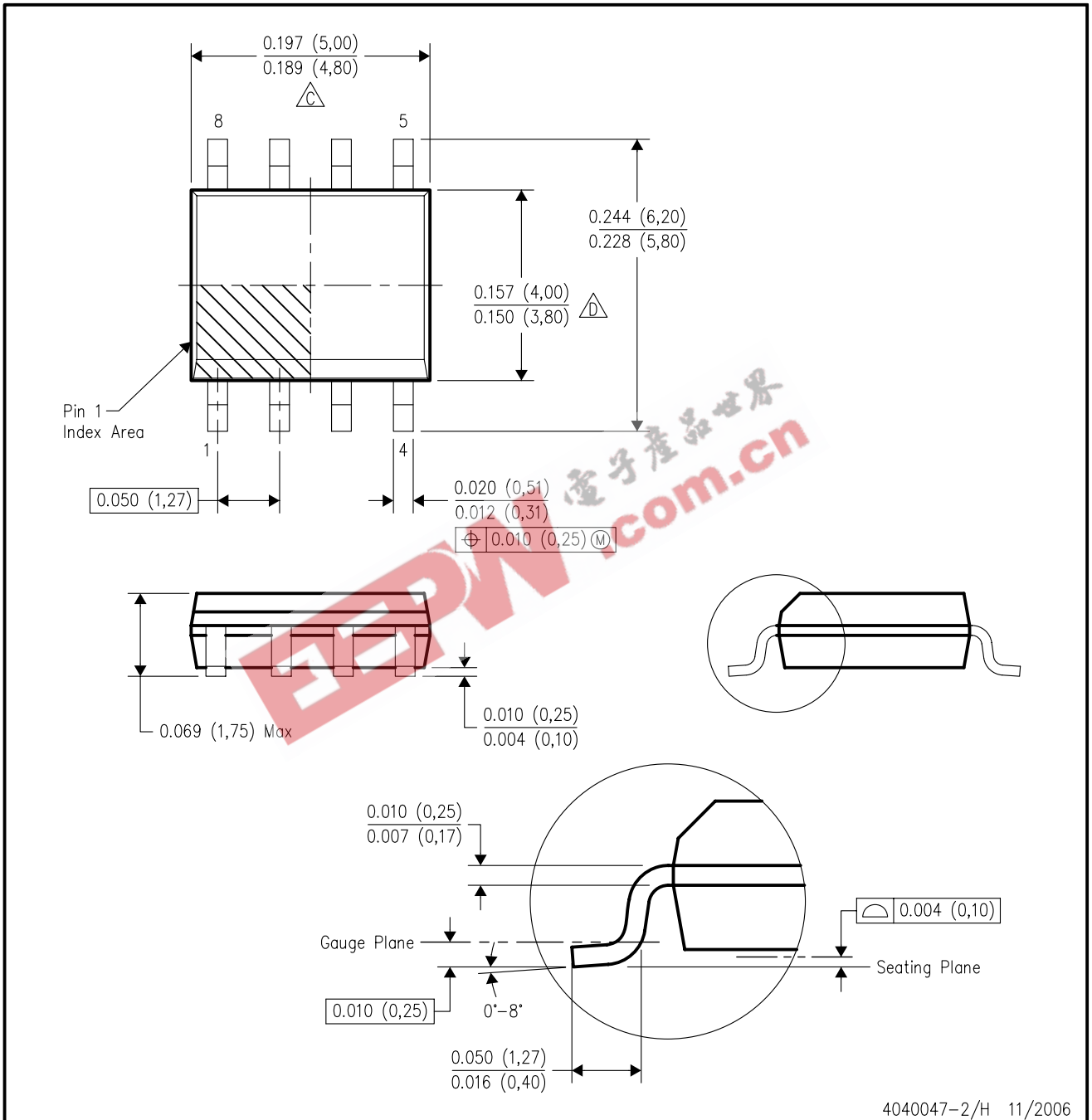

- NOTES:
- A. All linear dimensions are in inches (millimeters).
 - B. This drawing is subject to change without notice.
 - C. Body length does not include mold flash, protrusions, or gate burrs. Mold flash, protrusions, or gate burrs shall not exceed .006 (0,15) per end.
 - D. Body width does not include interlead flash. Interlead flash shall not exceed .017 (0,43) per side.
 - E. Reference JEDEC MS-012 variation AA.

IMPORTANT NOTICE

Texas Instruments Incorporated and its subsidiaries (TI) reserve the right to make corrections, modifications, enhancements, improvements, and other changes to its products and services at any time and to discontinue any product or service without notice. Customers should obtain the latest relevant information before placing orders and should verify that such information is current and complete. All products are sold subject to TI's terms and conditions of sale supplied at the time of order acknowledgment.

TI warrants performance of its hardware products to the specifications applicable at the time of sale in accordance with TI's standard warranty. Testing and other quality control techniques are used to the extent TI deems necessary to support this warranty. Except where mandated by government requirements, testing of all parameters of each product is not necessarily performed.

TI assumes no liability for applications assistance or customer product design. Customers are responsible for their products and applications using TI components. To minimize the risks associated with customer products and applications, customers should provide adequate design and operating safeguards.

TI does not warrant or represent that any license, either express or implied, is granted under any TI patent right, copyright, mask work right, or other TI intellectual property right relating to any combination, machine, or process in which TI products or services are used. Information published by TI regarding third-party products or services does not constitute a license from TI to use such products or services or a warranty or endorsement thereof. Use of such information may require a license from a third party under the patents or other intellectual property of the third party, or a license from TI under the patents or other intellectual property of TI.

Reproduction of information in TI data books or data sheets is permissible only if reproduction is without alteration and is accompanied by all associated warranties, conditions, limitations, and notices. Reproduction of this information with alteration is an unfair and deceptive business practice. TI is not responsible or liable for such altered documentation.

Resale of TI products or services with statements different from or beyond the parameters stated by TI for that product or service voids all express and any implied warranties for the associated TI product or service and is an unfair and deceptive business practice. TI is not responsible or liable for any such statements.

Following are URLs where you can obtain information on other Texas Instruments products and application solutions:

Products		Applications	
Amplifiers	amplifier.ti.com	Audio	www.ti.com/audio
Data Converters	dataconverter.ti.com	Automotive	www.ti.com/automotive
DSP	dsp.ti.com	Broadband	www.ti.com/broadband
Interface	interface.ti.com	Digital Control	www.ti.com/digitalcontrol
Logic	logic.ti.com	Military	www.ti.com/military
Power Mgmt	power.ti.com	Optical Networking	www.ti.com/opticalnetwork
Microcontrollers	microcontroller.ti.com	Security	www.ti.com/security
Low Power Wireless	www.ti.com/lpw	Telephony	www.ti.com/telephony
		Video & Imaging	www.ti.com/video
		Wireless	www.ti.com/wireless

Mailing Address: Texas Instruments
Post Office Box 655303 Dallas, Texas 75265