

TL7702A, TL7705A, TL7709A, TL7712A, TL7715A SUPPLY-VOLTAGE SUPERVISORS

SLVS028E – APRIL 1983 – REVISED JULY 1999

- Power-On Reset Generator
- Automatic Reset Generation After Voltage Drop
- Wide Supply-Voltage Range
- Precision Voltage Sensor
- Temperature-Compensated Voltage Reference
- True and Complement Reset Outputs
- Externally Adjustable Pulse Duration

D OR P PACKAGE
(TOP VIEW)

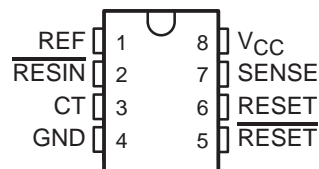

description

The TL77xxA family of integrated-circuit supply-voltage supervisors is specifically designed for use as reset controllers in microcomputer and microprocessor systems. The supply-voltage supervisor monitors the supply for undervoltage conditions at the SENSE input. During power up, the RESET output becomes active (low) when V_{CC} attains a value approaching 3.6 V. At this point (assuming that SENSE is above V_{IT+}), the delay timer function activates a time delay, after which outputs RESET and RESET go inactive (high and low, respectively). When an undervoltage condition occurs during normal operation, outputs RESET and RESET go active. To ensure that a complete reset occurs, the reset outputs remain active for a time delay after the voltage at the SENSE input exceeds the positive-going threshold value. The time delay is determined by the value of the external capacitor C_T: $t_d = 1.3 \times 10^4 \times C_T$, where C_T is in farads (F) and t_d is in seconds (s).

During power down (assuming that SENSE is below V_{IT-}), the outputs remain active until the V_{CC} falls below a maximum of 2 V. After this, the outputs are undefined.

An external capacitor (typically 0.1 μF for the TL77xxAC and TL77xxAI) must be connected to REF to reduce the influence of fast transients in the supply voltage.

The TL77xxAC series is characterized for operation from 0°C to 70°C. The TL77xxAI series is characterized for operation from -40°C to 85°C.

AVAILABLE OPTIONS

T _A	PACKAGED DEVICES		CHIP FORM (Y)
	SMALL OUTLINE (D)	PLASTIC DIP (P)	
0°C to 70°C	TL7702ACD TL7705ACD TL7709ACD TL7712ACD TL7715ACD	TL7702ACP TL7705ACP TL7709ACP TL7712ACP TL7715ACP	TL7702ACY TL7705ACY TL7709ACY TL7712ACY TL7715ACY
-40°C to 85°C	TL7702AID TL7705AID TL7709AID TL7712AID TL7715AID	TL7702AIP TL7705AIP TL7709AIP TL7712AIP TL7715AIP	— — — — —

The D package is available taped and reeled. Add the suffix R to the device type (e.g., TL7702ACDR). Chip forms are tested at 25°C.



Please be aware that an important notice concerning availability, standard warranty, and use in critical applications of Texas Instruments semiconductor products and disclaimers thereto appears at the end of this data sheet.

PRODUCTION DATA information is current as of publication date. Products conform to specifications per the terms of Texas Instruments standard warranty. Production processing does not necessarily include testing of all parameters.

 **TEXAS
INSTRUMENTS**

POST OFFICE BOX 655303 • DALLAS, TEXAS 75265

Copyright © 1999, Texas Instruments Incorporated

TL7702A, TL7705A, TL7709A, TL7712A, TL7715A SUPPLY-VOLTAGE SUPERVISORS

SLVS028E – APRIL 1983 – REVISED JULY 1999

functional block diagram

The functional block diagram is shown for illustrative purposes only; the actual circuit includes a trimming network to adjust the reference voltage and sense-comparator trip point.

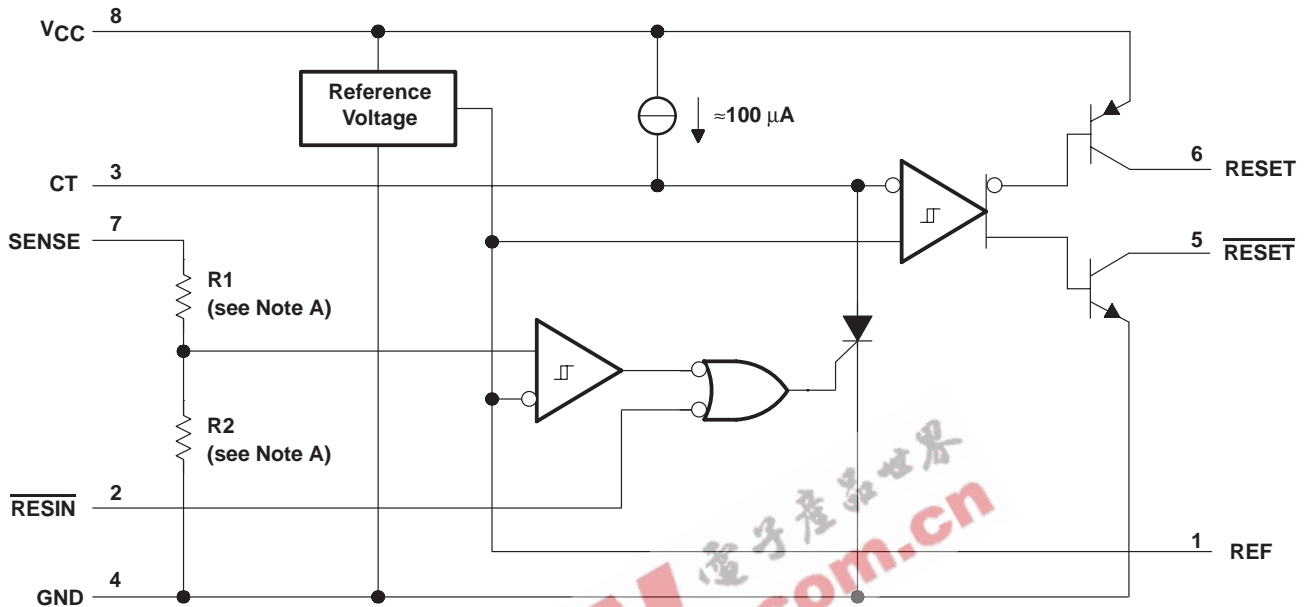

- NOTES: A. TL7702A: R1 = 0 Ω, R2 = open
 TL7705A: R1 = 7.8 kΩ, R2 = 10 kΩ
 TL7709A: R1 = 19.7 kΩ, R2 = 10 kΩ
 TL7712A: R1 = 32.7 kΩ, R2 = 10 kΩ
 TL7715A: R1 = 43.4 kΩ, R2 = 10 kΩ
 B. Resistor values shown are nominal.

timing diagram

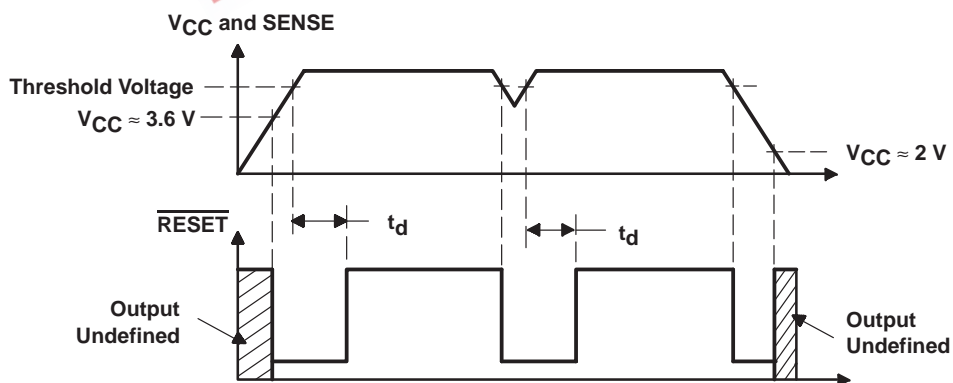

TL7702A, TL7705A, TL7709A, TL7712A, TL7715A SUPPLY-VOLTAGE SUPERVISORS

SLVS028E – APRIL 1983 – REVISED JULY 1999

absolute maximum ratings over operating free-air temperature (unless otherwise noted)†

Supply voltage, V_{CC} (see Note 1)	20 V
Input voltage range, V_I , \overline{RESIN}	–0.3 V to 20 V
Input voltage range, V_I , SENSE: TL7702A (see Note 2)	–0.3 V to 6 V
TL7705A	–0.3 V to 20 V
TL7709A	–0.3 V to 20 V
TL7712A, TL7715A	–0.3 V to 20 V
High-level output current, I_{OH} , \overline{RESET}	–30 mA
Low-level output current, I_{OL} , \overline{RESET}	30 mA
Package thermal impedance, θ_{JA} (see Notes 3 and 4): D package	97°C/W
P package	127°C/W
Lead temperature 1,6 mm (1/16 inch) from case for 10 seconds: D or P package	260°C
Storage temperature range, T_{stg}	–65°C to 150°C

† Stresses beyond those listed under “absolute maximum ratings” may cause permanent damage to the device. These are stress ratings only, and functional operation of the device at these or any other conditions beyond those indicated under “recommended operating conditions” is not implied. Exposure to absolute-maximum-rated conditions for extended periods may affect device reliability.

- NOTES:
- All voltage values are with respect to the network ground terminal.
 - For proper operation of the TL7702A, the voltage applied to the SENSE terminal should not exceed $V_{CC} - 1$ V or 6 V, whichever is less.
 - Maximum power dissipation is a function of $T_J(\max)$, θ_{JA} , and T_A . The maximum allowable power dissipation at any allowable ambient temperature is $P_D = (T_J(\max) - T_A)/\theta_{JA}$. Operating at the absolute maximum T_J of 150°C can impact reliability.
 - The package thermal impedance is calculated in accordance with JEDEC 51, except for through-hole packages, which use a trace length of zero.

recommended operating conditions

		MIN	MAX	UNIT
Supply voltage, V_{CC}		3.5	18	V
High-level input voltage at \overline{RESIN} , V_{IH}		2		V
Low-level input voltage at \overline{RESIN} , V_{IL}			0.6	V
Input voltage, SENSE, V_I	TL7702A	0	See Note 2	V
	TL7705A	0	10	
	TL7709A	0	15	
	TL7712A	0	20	
	TL7715A	0	20	
High-level output current, \overline{RESET} , I_{OH}			–16	mA
Low-level output current, \overline{RESET} , I_{OL}			16	mA
Timing capacitor, C_T			10	μF
Operating free-air temperature range, T_A	TL77xxAC	0	70	°C
	TL77xxAI	–40	85	

NOTE 2: For proper operation of the TL7702A, the voltage applied to the SENSE terminal should not exceed $V_{CC} - 1$ V or 6 V, whichever is less.

TL7702A, TL7705A, TL7709A, TL7712A, TL7715A SUPPLY-VOLTAGE SUPERVISORS

SLVS028E – APRIL 1983 – REVISED JULY 1999

electrical characteristics over recommended operating conditions (unless otherwise noted)

PARAMETER		TEST CONDITIONS†	TL77xxAC TL77xxAI			UNIT	
			MIN	TYP	MAX		
V _{OH}	High-level output voltage, $\overline{\text{RESET}}$	I _{OH} = -16 mA	V _{CC} -1.5			V	
V _{OL}	Low-level output voltage, $\overline{\text{RESET}}$	I _{OL} = 16 mA	0.4			V	
V _{ref}	Reference voltage	T _A = 25°C	2.48	2.53	2.58	V	
V _{IT-}	Negative-going input threshold voltage, SENSE	T _A = 25°C	TL7702A	2.48	2.53	2.58	V
			TL7705A	4.5	4.55	4.6	
			TL7709A	7.5	7.6	7.7	
			TL7712A	10.6	10.8	11	
			TL7715A	13.2	13.5	13.8	
V _{hys}	Hysteresis, SENSE (V _{IT+} - V _{IT-})	T _A = 25°C	TL7702A	10		mV	
			TL7705A	15			
			TL7709A	20			
			TL7712A	35			
			TL7715A	45			
I _I	Input current	RESIN	V _I = 2.4 V to V _{CC}		20	μA	
			V _I = 0.4 V		-100		
		SENSE	TL7702A	V _{ref} < V _I < V _{CC} - 1.5 V		0.5	2
I _{OH}	High-level output current, $\overline{\text{RESET}}$	V _O = 18 V	50			μA	
I _{OL}	Low-level output current, $\overline{\text{RESET}}$	V _O = 0	-50			μA	
I _{CC}	Supply current	All inputs and outputs open	1.8	3		mA	

† All electrical characteristics are measured with 0.1-μF capacitors connected at REF, CT, and V_{CC} to GND.

switching characteristics over recommended operating conditions (unless otherwise noted)

PARAMETER		TEST CONDITIONS‡	TL77xxAC TL77xxAI			UNIT
			MIN	TYP	MAX	
Output pulse duration		C _T = 0.1 μF	0.65	1.2	2.6	μs
Input pulse duration at RESIN			0.4			μs
t _{w(S)}	Pulse duration at SENSE input to switch outputs	V _{IH} = V _{IT-} + 200 mV, V _{IL} = V _{IT-} - 200 mV	2			μs
t _{pd}	Propagation delay time, $\overline{\text{RESIN}}$ to $\overline{\text{RESET}}$	V _{CC} = 5 V	1			μs
t _r	Rise time	V _{CC} = 5 V, See Note 5	$\overline{\text{RESET}}$		0.2	μs
			$\overline{\text{RESET}}$		3.5	
t _f	Fall time	V _{CC} = 5 V, See Note 5	$\overline{\text{RESET}}$		3.5	μs
			$\overline{\text{RESET}}$		0.2	

‡ All switching characteristics are measured with 0.1-μF capacitors connected at REF and V_{CC} to GND.

NOTE 5: The rise and fall times are measured with a 4.7-kΩ load resistor at $\overline{\text{RESET}}$ and $\overline{\text{RESET}}$.

TL7702A, TL7705A, TL7709A, TL7712A, TL7715A SUPPLY-VOLTAGE SUPERVISORS

SLVS028E – APRIL 1983 – REVISED JULY 1999

electrical characteristics over recommended operating conditions, $T_A = 25^\circ\text{C}$ (unless otherwise noted)

PARAMETER		TEST CONDITIONS†	TL77xxAY			UNIT
			MIN	TYP	MAX	
V_{ref}	Reference voltage		2.53			V
V_{IT-}	Negative-going input threshold voltage, SENSE	TL7702A	2.53			V
		TL7705A	4.55			
		TL7709A	7.6			
		TL7712A	10.8			
		TL7715A	13.5			
V_{hys}	Hysteresis, SENSE ($V_{IT+} - V_{IT-}$)	TL7702A	10			mV
		TL7705A	15			
		TL7709A	20			
		TL7712A	35			
		TL7715A	45			
I_I	Input current, SENSE	TL7702A	$V_{ref} < V_I < V_{CC} - 1.5\text{ V}$			μA
I_{CC}	Supply current	All inputs and outputs open		1.8		mA

† All electrical characteristics are measured with 0.1- μF capacitors connected at REF, CT, and V_{CC} to GND.

switching characteristics over recommended operating conditions, $T_A = 25^\circ\text{C}$ (unless otherwise noted)

PARAMETER		TEST CONDITIONS‡	TL77xxAY			UNIT
			MIN	TYP	MAX	
t_d	Output pulse time delay	$C_T = 0.1\ \mu\text{F}$	1.2			μs

‡ All switching characteristics are measured with 0.1- μF capacitors connected at REF and V_{CC} to GND.

TL7702A, TL7705A, TL7709A, TL7712A, TL7715A SUPPLY-VOLTAGE SUPERVISORS

SLVS028E – APRIL 1983 – REVISED JULY 1999

PARAMETER MEASUREMENT INFORMATION

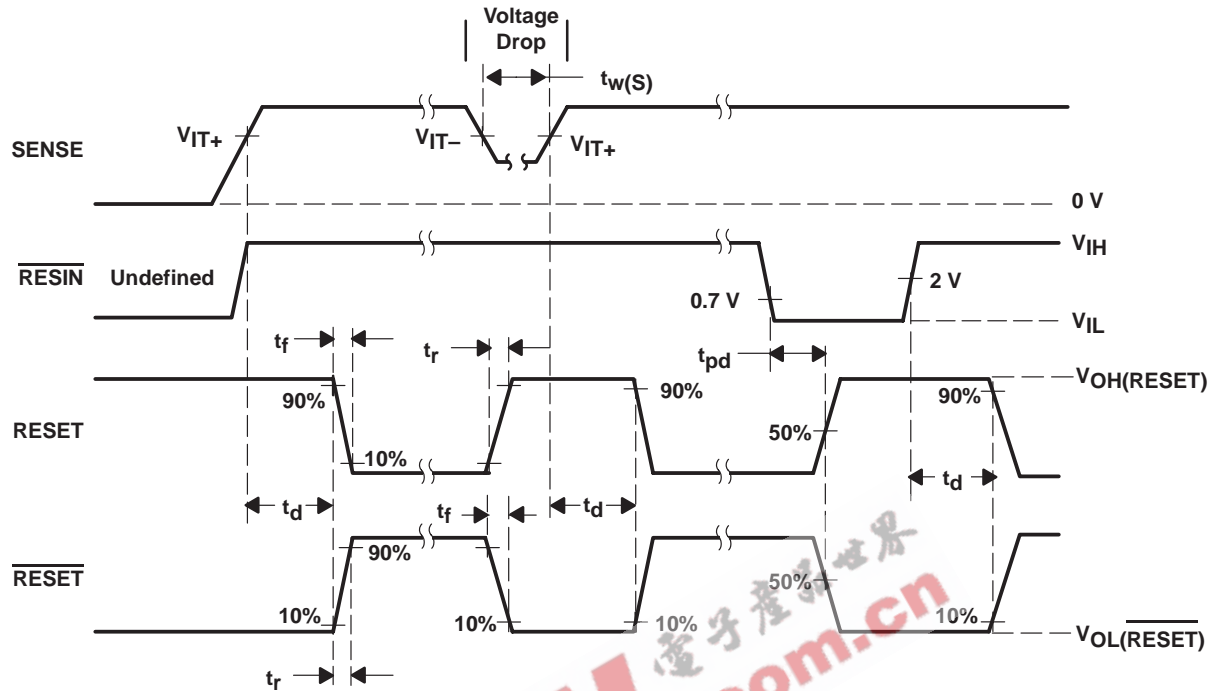
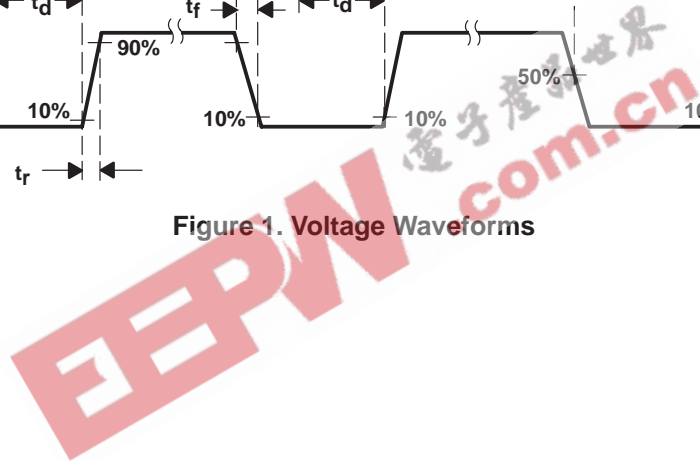

Figure 1. Voltage Waveforms



TYPICAL CHARACTERISTICS†

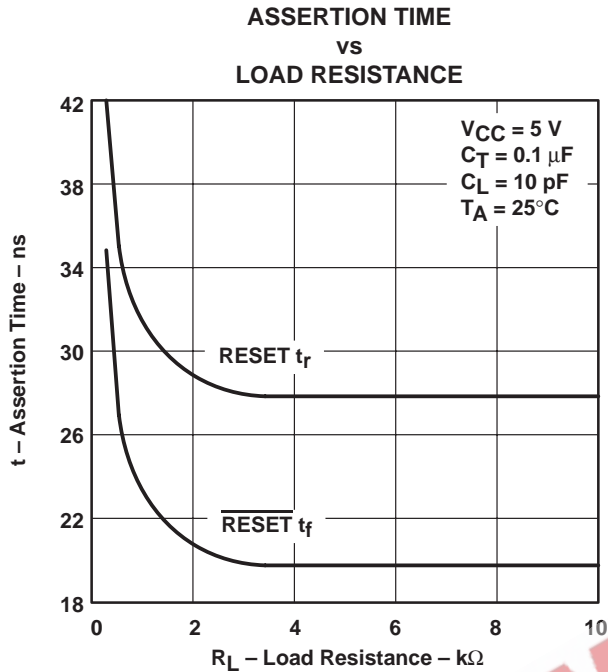

Figure 2

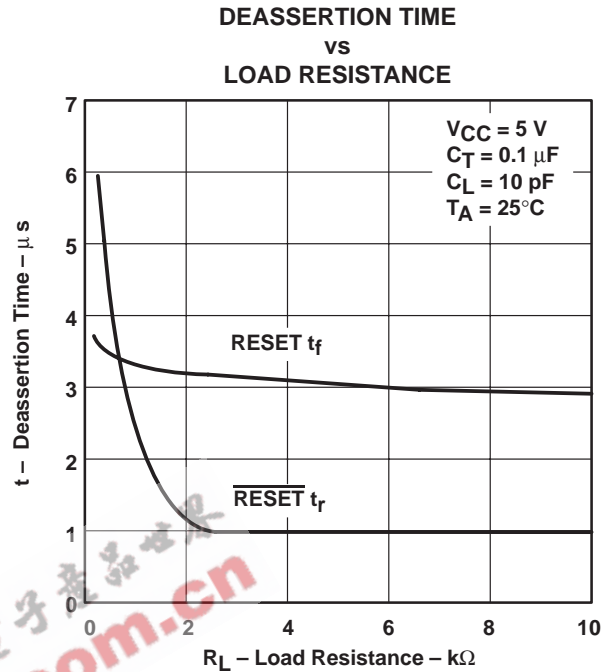

Figure 3

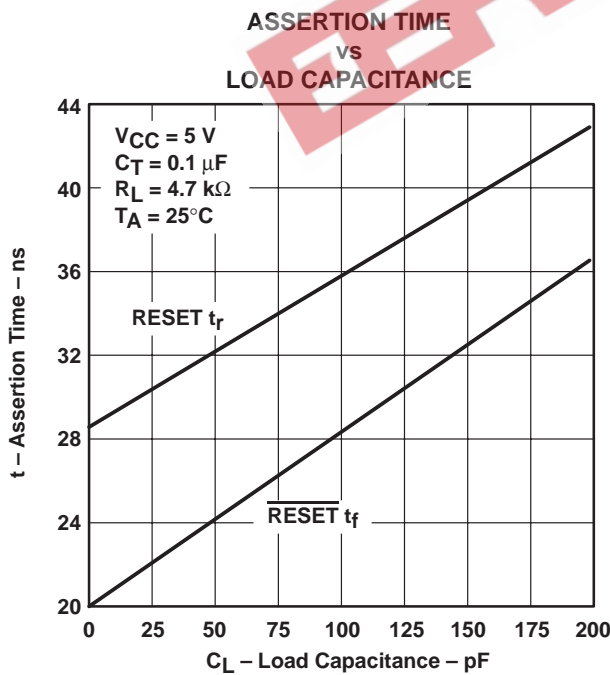

Figure 4

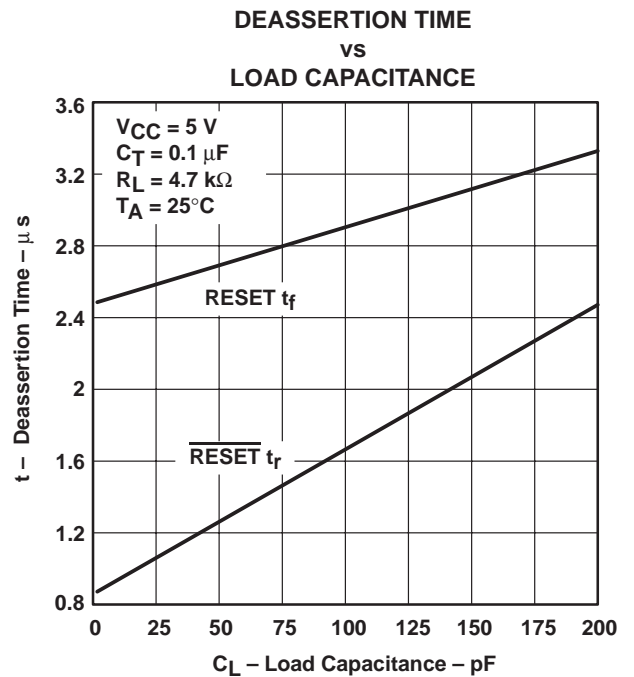

Figure 5

† For proper operation, both RESET and $\overline{\text{RESET}}$ should be terminated with resistors of similar value. Failure to do so may cause unwanted plateauing in either output waveform during switching.

TL7702A, TL7705A, TL7709A, TL7712A, TL7715A SUPPLY-VOLTAGE SUPERVISORS

SLVS028E – APRIL 1983 – REVISED JULY 1999

APPLICATION INFORMATION

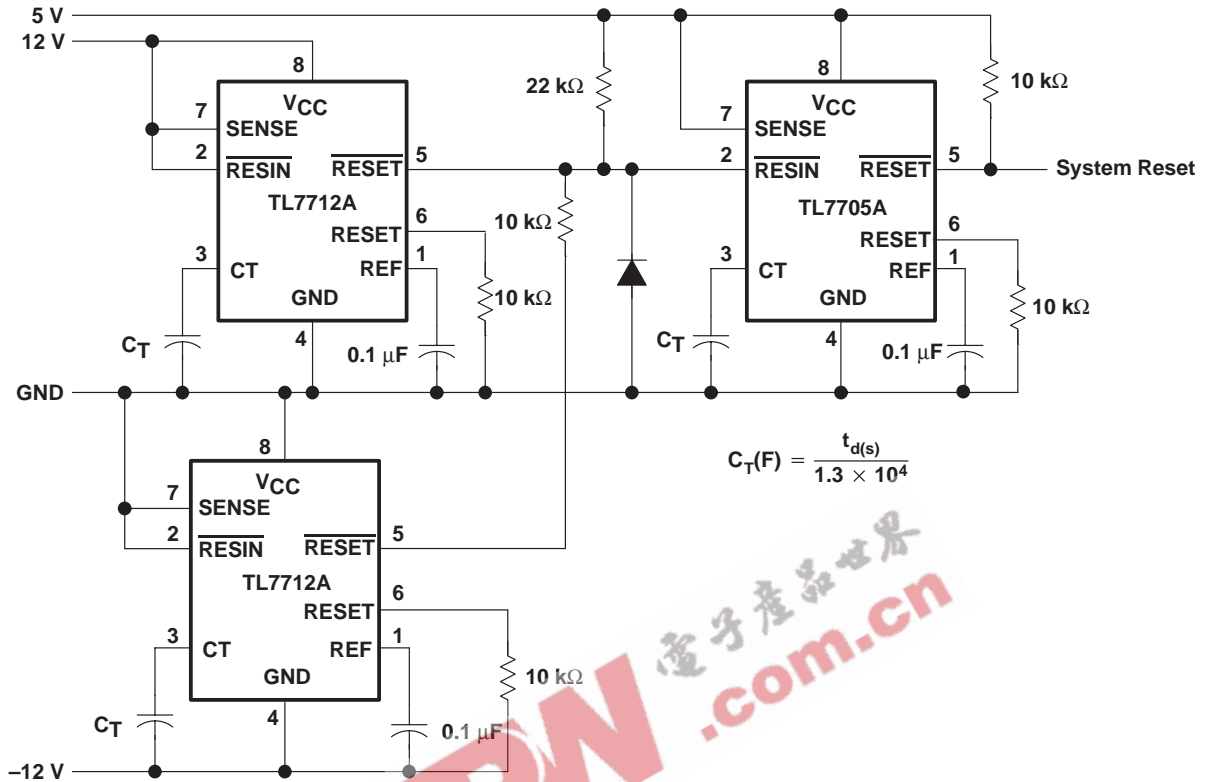

Figure 6. Multiple Power-Supply System Reset Generation

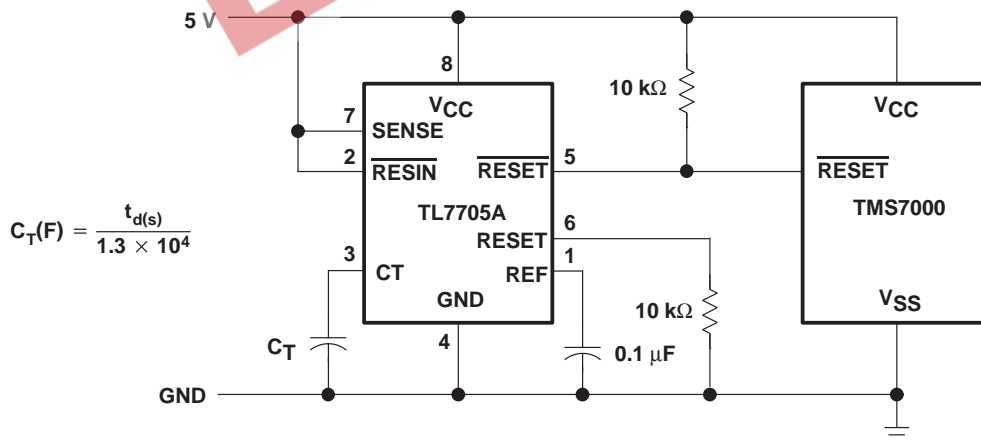

Figure 7. Reset Controller for TMS7000 System

APPLICATION INFORMATION

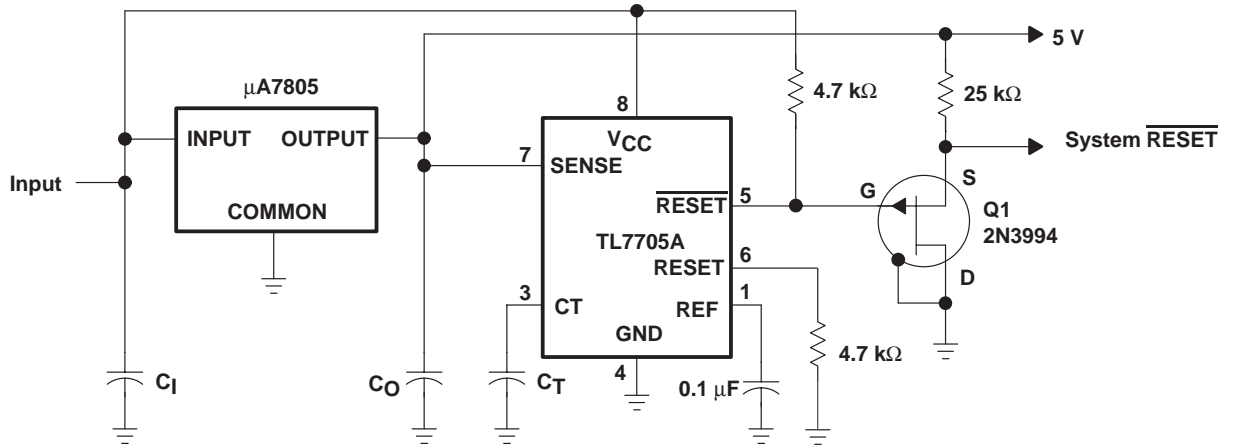

Figure 8. Eliminating Undefined States Using a P-Channel JFET

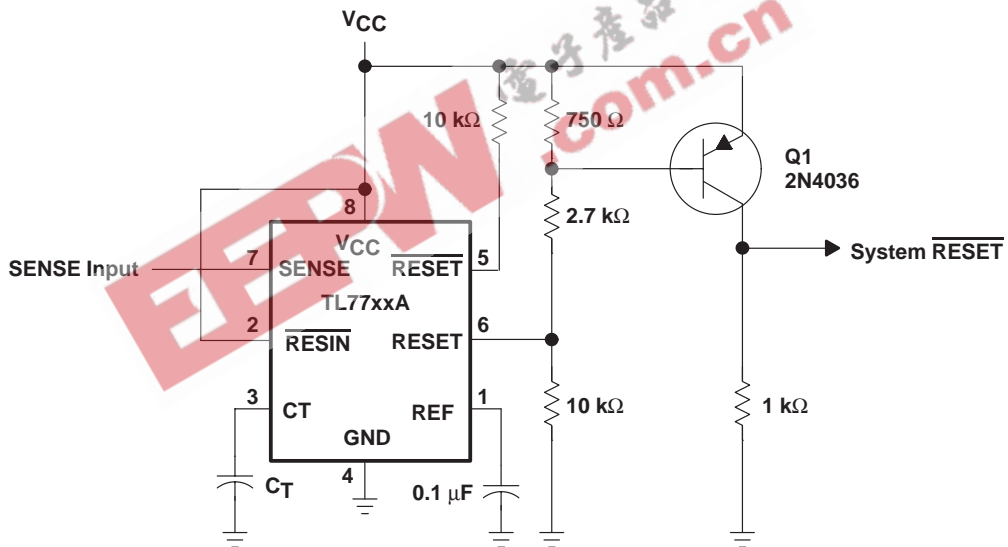

Figure 9. Eliminating Undefined States Using a pnp Transistor

IMPORTANT NOTICE

Texas Instruments and its subsidiaries (TI) reserve the right to make changes to their products or to discontinue any product or service without notice, and advise customers to obtain the latest version of relevant information to verify, before placing orders, that information being relied on is current and complete. All products are sold subject to the terms and conditions of sale supplied at the time of order acknowledgement, including those pertaining to warranty, patent infringement, and limitation of liability.

TI warrants performance of its semiconductor products to the specifications applicable at the time of sale in accordance with TI's standard warranty. Testing and other quality control techniques are utilized to the extent TI deems necessary to support this warranty. Specific testing of all parameters of each device is not necessarily performed, except those mandated by government requirements.

CERTAIN APPLICATIONS USING SEMICONDUCTOR PRODUCTS MAY INVOLVE POTENTIAL RISKS OF DEATH, PERSONAL INJURY, OR SEVERE PROPERTY OR ENVIRONMENTAL DAMAGE ("CRITICAL APPLICATIONS"). TI SEMICONDUCTOR PRODUCTS ARE NOT DESIGNED, AUTHORIZED, OR WARRANTED TO BE SUITABLE FOR USE IN LIFE-SUPPORT DEVICES OR SYSTEMS OR OTHER CRITICAL APPLICATIONS. INCLUSION OF TI PRODUCTS IN SUCH APPLICATIONS IS UNDERSTOOD TO BE FULLY AT THE CUSTOMER'S RISK.

In order to minimize risks associated with the customer's applications, adequate design and operating safeguards must be provided by the customer to minimize inherent or procedural hazards.

TI assumes no liability for applications assistance or customer product design. TI does not warrant or represent that any license, either express or implied, is granted under any patent right, copyright, mask work right, or other intellectual property right of TI covering or relating to any combination, machine, or process in which such semiconductor products or services might be or are used. TI's publication of information regarding any third party's products or services does not constitute TI's approval, warranty or endorsement thereof.