

TP3070, TP3071, TP3070-X COMBO® II Programmable PCM CODEC/Filter

General Description

The TP3070 and TP3071 are second-generation combined PCM CODEC and Filter devices optimized for digital switching applications on subscriber line and trunk cards. Using advanced switched capacitor techniques, COMBO II combines transmit bandpass and receive lowpass channel filters with a companding PCM encoder and decoder. The devices are A-law and μ -law selectable and employ a conventional serial PCM interface capable of being clocked up to 4.096 MHz. A number of programmable functions may be controlled via a serial control port.

Channel gains are programmable over a 25.4 dB range in each direction, and a programmable filter is included to enable Hybrid Balancing to be adjusted to suit a wide range of loop impedance conditions. Both transformer and active SLIC interface circuits with real or complex termination impedances can be balanced by this filter, with cancellation in excess of 30 dB being readily achievable when measured across the passband against standard test termination networks.

To enable COMBO II to interface to the SLIC control leads, a number of programmable latches are included; each may be configured as either an input or an output. The TP3070 provides 6 latches and the TP3071 5 latches.

Features

- Complete CODEC and FILTER system including:
 - Transmit and receive PCM channel filters
 - μ -law or A-law companding encoder and decoder
 - Receive power amplifier drives 300 Ω
 - 4.096 MHz serial PCM data (max)
- Programmable Functions:
 - Transmit gain: 25.4 dB range, 0.1 dB steps
 - Receive gain: 25.4 dB range, 0.1 dB steps
 - Hybrid balance cancellation filter
 - Time-slot assignment; up to 64 slots/frame
 - 2 port assignment (TP3070)
 - 6 interface latches (TP3070)
 - A or μ -law
 - Analog loopback
 - Digital loopback
- Direct interface to solid-state SLICs
- Simplifies transformer SLIC; single winding secondary
- Standard serial control interface
- 80 mW operating power (typ)
- 1.5 mW standby power (typ)
- Designed for CCITT and LSSGR applications
- TTL and CMOS compatible digital interfaces
- Extended temperature versions available for -40°C to $+85^{\circ}\text{C}$ (TP3070V-X)

Note: See also AN-614, COMBO II application guide.

Block Diagram

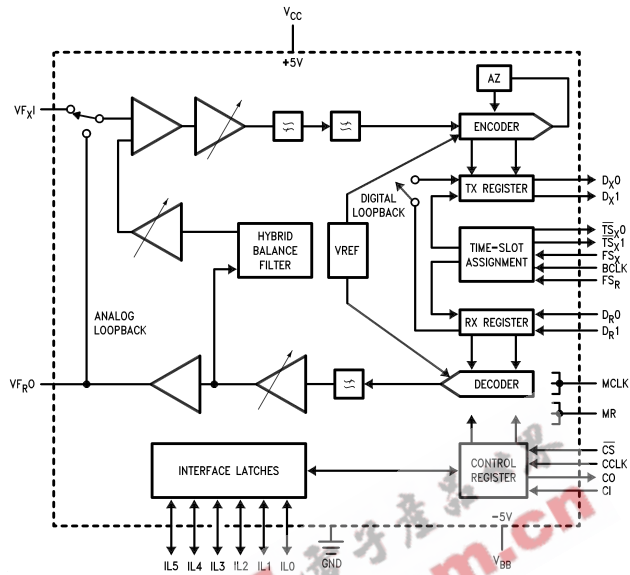
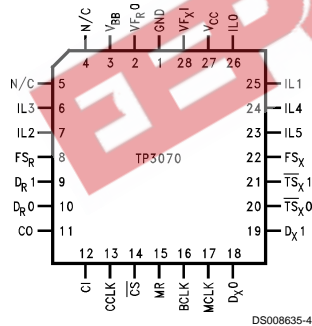
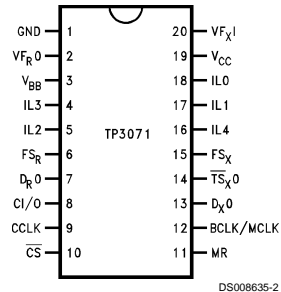

FIGURE 1.

Connection Diagrams



Order Number TP3070V
(0°C to +70°C)
Order Number TP3070V-X
(-40°C to +85°C)
See NS Package Number V28A



Order Number TP3071J
See NS Package Number J20A
Order Number TP3071N
See NS Package Number N20A

Pin Descriptions

Pin	Description
V _{CC}	+5V ±5% power supply.
V _{BB}	-5V ±5% power supply.
GND	Ground. All analog and digital signals are referenced to this pin.
FS _X	Transmit Frame Sync input. Normally a pulse or squarewave with an 8 kHz repetition rate is applied to this input to define the start of the transmit time slot assigned to this device (non-delayed data timing mode), or the start of the transmit frame (delayed data timing mode using the internal time-slot assignment counter).

Pin Descriptions (Continued)

Pin	Description
FS _R	Receive Frame Sync input. Normally a pulse or squarewave with an 8 kHz repetition rate is applied to this input to define the start of the receive time slot assigned to this device (non-delayed data timing mode), or the start of the receive frame (delayed data timing mode using the internal time-slot assignment counter).
BCLK	Bit clock input used to shift PCM data into and out of the D _R and D _X pins. BCLK may vary from 64 kHz to 4.096 MHz in 8 kHz increments, and must be synchronous with MCLK.
MCLK	Master clock input used by the switched capacitor filters and the encoder and decoder sequencing logic. Must be 512 kHz, 1.536 MHz, 1.544 MHz, 2.048 MHz or 4.096 MHz and synchronous with BCLK.
VF _{XI}	The Transmit analog high-impedance input. Voice frequency signals present on this input are encoded as an A-law or μ -law PCM bit stream and shifted out on the selected D _X pin.
VF _{RO}	The Receive analog power amplifier output, capable of driving load impedances as low as 300 Ω (depending on the peak overload level required). PCM data received on the assigned D _R pin is decoded and appears at this output as voice frequency signals.
D _{X0} D _{X1}	D _{X1} is available on the TP3070 only; D _{X0} is available on all devices. These Transmit Data TRI-STATE [®] outputs remain in the high impedance state except during the assigned transmit time slot on the assigned port, during which the transmit PCM data byte is shifted out on the rising edges of BCLK.
\overline{TS}_{X0} \overline{TS}_{X1}	\overline{TS}_{X1} is available on the TP3070 only; \overline{TS}_{X0} is available on all devices. Normally these open-drain outputs are floating in a high impedance state except when a time-slot is active on one of the D _X outputs, when the appropriate \overline{TS}_{X} output pulls low to enable a backplane line-driver.
D _{R0} D _{R1}	D _{R1} is available on the TP3070 only; D _{R0} is available on all devices. These receive data inputs are inactive except during the assigned receive time slot of the assigned port when the receive PCM data is shifted in on the falling edges of BCLK.
CCLK	Control Clock input. This clock shifts serial control information into or out from CI/O and CO when the \overline{CS} input is low, depending on the current instruction. CCLK may be asynchronous with the other system clocks.

Pin	Description
CI/O	This is the Control Data I/O pin which is provided on the TP3071. Serial control information is shifted to or read from COMBO II on this pin when \overline{CS} is low. The direction of the data is determined by the current instruction as defined in <i>Table 1</i> .
CI	This is a separate Control Input, available only on the TP3070. It can be connected to CO if required.
CO	This is a separate Control Output, available only on the TP3070. It can be connected to CI if required.
\overline{CS}	Chip Select input. When this pin is low, control information can be written to or read from COMBO II via the CI/O pin (or CI and CO).
IL5–IL0	IL5 through IL0 are available on the TP3070. IL4 through IL0 are available on the TP3071. Each Interface Latch I/O pin may be individually programmed as an input or an output determined by the state of the corresponding bit in the Latch Direction Register (LDR). For pins configured as inputs, the logic state sensed on each input is latched into the Interface Latch Register (ILR) whenever control data is written to COMBO II, while \overline{CS} is low, and the information is shifted out on the CO (or CI/O) pin. When configured as outputs, control data written into the ILR appears at the corresponding IL pins.
MR	This logic input must be pulled low for normal operation of COMBO II. When pulled momentarily high (at least 1 μ sec.), all programmable registers in the device are reset to the states specified under "Power-On Initialization".
NC	No Connection. Do not connect to this pin. Do not route traces through this pin.

Functional Description

POWER-ON INITIALIZATION

When power is first applied, power-on reset circuitry initializes the COMBO II and puts it into the power-down state. The gain control registers for the transmit and receive gain sections are programmed to OFF (00000000), the hybrid balance circuit is turned off, the power amp is disabled and the device is in the non-delayed timing mode. The Latch Direction Register (LDR) is pre-set with all IL pins programmed as inputs, placing the SLIC interface pins in a high impedance state. The CI/O pin is set as an input ready for the first control byte of the initialization sequence. Other initial states in the Control Register are indicated in Section 2.0.

A reset to these same initial conditions may also be forced by driving the MR pin momentarily high. This may be done either when powered-up or down. For normal operation this pin must be pulled low. If not used, MR should be hard-wired to ground.

The desired modes for all programmable functions may be initialized via the control port prior to a Power-up command.

Functional Description (Continued)

POWER-DOWN STATE

Following a period of activity in the powered-up state the power-down state may be re-entered by writing any of the control instructions into the serial control port with the "P" bit set to "1" as indicated in *Table 1*. It is recommended that the chip be powered down before writing any additional instructions. In the power-down state, all non-essential circuitry is de-activated and the D_{x0} (and D_{x1}) outputs are in the high impedance TRI-STATE condition.

The coefficients stored in the Hybrid Balance circuit and the Gain Control registers, the data in the LDR and ILR, and all control bits remain unchanged in the power-down state unless changed by writing new data via the serial control port, which remains active. The outputs of the Interface Latches also remain active, maintaining the ability to monitor and control the SLIC.

TRANSMIT FILTER AND ENCODER

The Transmit section input, $V_{F_{x1}}$, is a high impedance summing input which is used as the differencing point for the internal hybrid balance cancellation signal. No external components are necessary to set the gain. Following this circuit is a programmable gain/attenuation amplifier which is controlled by the contents of the Transmit Gain Register (see Programmable Functions section). An active pre-filter then precedes the 3rd order high-pass and 5th order low-pass switched capacitor filters. The A/D converter has a compressing characteristic according to the standard CCITT A or $\mu 255$ coding laws, which must be selected by a control instruction during initialization (see *Table 1* and *Table 2*). A precision on-chip voltage reference ensures accurate and highly stable transmission levels. Any offset voltage arising in the gain-set amplifier, the filters or the comparator is canceled by an internal auto-zero circuit.

Each encode cycle begins immediately following the assigned Transmit time-slot. The total signal delay referenced to the start of the time-slot is approximately 165 μs (due to the Transmit Filter) plus 125 μs (due to encoding delay), which totals 290 μs . Data is shifted out on D_{x0} or D_{x1} during the selected time slot on eight rising edges of BCLK.

DECODER AND RECEIVE FILTER

PCM data is shifted into the Decoder's Receive PCM Register via the D_{R0} or D_{R1} pin during the selected time-slot on the 8 falling edges of BCLK. The Decoder consists of an expanding DAC with either A or $\mu 255$ law decoding characteristic, which is selected by the same control instruction used to select the Encode law during initialization. Following the Decoder is a 5th order low-pass switched capacitor filter with integral $\text{Sin } x/x$ correction for the 8 kHz sample and hold. A programmable gain amplifier, which must be set by writing to the Receive Gain Register, is included, and finally a Power Amplifier capable of driving a 300 Ω load to $\pm 3.5\text{V}$, a 600 Ω load to $\pm 3.8\text{V}$ or a 15 k Ω load to $\pm 4.0\text{V}$ at peak overload.

A decode cycle begins immediately after the assigned receive time-slot, and 10 μs later the Decoder DAC output is updated. The total signal delay is 10 μs plus 120 μs (filter delay) plus 62.5 μs ($1/2$ frame) which gives approximately 190 μs .

PCM INTERFACE

The FS_x and FS_R frame sync inputs determine the beginning of the 8-bit transmit and receive time-slots respectively. They may have any duration from a single cycle of BCLK HIGH to one MCLK period LOW. Two different relationships may be established between the frame sync inputs and the actual time-slots on the PCM busses by setting bit 3 in the Control Register (see *Table 2*). Non-delayed data mode is similar to long-frame timing on the TP3050/60 series of devices (COMBO); time-slots begin nominally coincident with the rising edge of the appropriate FS input. The alternative is to use Delayed Data mode, which is similar to short-frame sync timing on COMBO, in which each FS input must be high at least a half-cycle of BCLK earlier than the time-slot. The Time-Slot Assignment circuit on the device can only be used with Delayed Data timing.

When using Time-Slot Assignment, the beginning of the first time-slot in a frame is identified by the appropriate FS input. The actual transmit and receive time-slots are then determined by the internal Time-Slot Assignment counters.

Transmit and Receive frames and time-slots may be skewed from each other by any number of BCLK cycles. During each assigned Transmit time-slot, the selected $D_{x0}/1$ output shifts data out from the PCM register on the rising edges of BCLK. TS_{x0} (or TS_{x1} as appropriate) also pulls low for the first $7\frac{1}{2}$ bit times of the time-slot to control the TRI-STATE Enable of a backplane line-driver. Serial PCM data is shifted into the selected $D_{R0}/1$ input during each assigned Receive time-slot on the falling edges of BCLK. D_{x0} or D_{x1} and D_{R0} or D_{R1} are selectable on the TP3070 only, see Section 6.

Functional Description (Continued)

TABLE 1. Programmable Register Instructions

Function	Byte 1 (Note 1)								Byte 2 (Note 1)							
	7	6	5	4	3	2	1	0	7	6	5	4	3	2	1	0
Single Byte Power-Up/Down	P	X	X	X	X	X	0	X	None							
Write Control Register	P	0	0	0	0	0	1	X	See Table 2							
Read-Back Control Register	P	0	0	0	0	1	1	X	See Table 2							
Write to Interface Latch Register	P	0	0	0	1	0	1	X	See Table 4							
Read Interface Latch Register	P	0	0	0	1	1	1	X	See Table 4							
Write Latch Direction Register	P	0	0	1	0	0	1	X	See Table 3							
Read Latch Direction Register	P	0	0	1	0	1	1	X	See Table 3							
Write Receive Gain Register	P	0	1	0	0	0	1	X	See Table 8							
Read Receive Gain Register	P	0	1	0	0	1	1	X	See Table 8							
Write Transmit Gain Register	P	0	1	0	1	0	1	X	See Table 7							
Read Transmit Gain Register	P	0	1	0	1	1	1	X	See Table 7							
Write Receive Time-Slot/Port	P	1	0	0	1	0	1	X	See Table 6							
Read-Back Receive Time-Slot/Port	P	1	0	0	1	1	1	X	See Table 6							
Write Transmit Time-Slot/Port	P	1	0	1	0	0	1	X	See Table 6							
Read-Back Transmit Time-Slot/Port	P	1	0	1	0	1	1	X	See Table 6							
Write Hybrid Balance Register 1	P	0	1	1	0	0	1	X	Derive from Optimization Routine in TP3077SW Program							
Read Hybrid Balance Register 1	P	0	1	1	0	1	1	X								
Write Hybrid Balance Register 2	P	0	1	1	1	0	1	X								
Read Hybrid Balance Register 2	P	0	1	1	1	1	1	X								
Write Hybrid Balance Register 3	P	1	0	0	0	0	1	X								
Read Hybrid Balance Register 3	P	1	0	0	0	1	1	X								

Note 1: Bit 7 of bytes 1 and 2 is always the first bit clocked into or out from the CI, CO or CIO pin. X = don't care.

Note 2: "P" is the power-up/down control bit, see "Power-Up/Down Control" section. ("0" = Power Up, "1" = Power Down)

Note 3: Other register address codes are invalid and should not be used.

SERIAL CONTROL PORT

Control information and data are written into or read-back from COMBO II via the serial control port consisting of the control clock CCLK, the serial data input/output CI/O, (or separate input, CI, and output, CO, on the TP3070 only), and the Chip Select input, \overline{CS} . All control instructions require 2 bytes, as listed in Table 1, with the exception of a single byte power-up/down command. The byte 1 bits are used as follows: bit 7 specifies power up or power down; bits 6, 5, 4 and 3 specify the register address; bit 2 specifies whether the instruction is read or write; bit 1 specifies a one or two byte instruction; and bit 0 is not used.

To shift control data into COMBO II, CCLK must be pulsed 8 times while \overline{CS} is low. Data on the CI/O (or CI) input is shifted into the serial input register on the falling edge of each CCLK pulse. After all data is shifted in, the contents of the input shift register are decoded, and may indicate that a 2nd byte of control data will follow. This second byte may either be defined by a second byte-wide \overline{CS} pulse or may follow the first contiguously, i.e. it is not mandatory for \overline{CS} to return high between the first and second control bytes. At the end of CCLK8 in the 2nd control byte the data is loaded into the appropriate programmable register. \overline{CS} may remain low continuously when programming successive registers, if desired. However, \overline{CS} should be set high when no data transfers are in progress.

To readback Interface Latch data or status information from COMBO II, the first byte of the appropriate instruction is

strobed in while \overline{CS} is low, as defined in Table 1. \overline{CS} must be kept low, or be taken low again for a further 8 CCLK cycles, during which the data is shifted onto the CO or CIO pin on the rising edges of CCLK. When \overline{CS} is high the CO or CIO pin is in the high-impedance TRI-STATE, enabling the CI/O pins of many devices to be multiplexed together.

If \overline{CS} returns high during either byte 1 or byte 2 before all eight CCLK pulses of that byte occur, both the bit count and byte count are reset and register contents are not affected. This prevents loss of synchronization in the control interface as well as corruption of register data due to processor interrupt or other problem. When \overline{CS} returns low again, the device will be ready to accept bit 1 of byte 1 of a new instruction.

Programmable Functions

1.0 POWER-UP/DOWN CONTROL

Following power-on initialization, power-up and power-down control may be accomplished by writing any of the control instructions listed in Table 1 into COMBO II with the "P" bit set to "0" for power-up or "1" for power-down. Normally it is recommended that all programmable functions be initially programmed while the device is powered down. Power state control can then be included with the last programming instruction or the separate single-byte instruction. Any of the programmable registers may also be modified while the de-

Programmable Functions (Continued)

vice is powered-up or down by setting the "P" bit as indicated. When the power-up or down control is entered as a single byte instruction, bit one (1) must be reset to a 0.

When a power-up command is given, all de-activated circuits are activated, but the TRI-STATE PCM output(s), D_{x0} (and D_{x1}), will remain in the high impedance state until the second FS_x pulse after power-up.

2.0 CONTROL REGISTER INSTRUCTION

The first byte of a READ or WRITE instruction to the Control Register is as shown in *Table 1*. The second byte has the following bit functions:

TABLE 2. Control Register Byte 2 Functions

Bit Number and Name								Function
7	6	5	4	3	2	1	0	
F_1	F_0	MA	IA	DN	DL	AL	PP	
0	0							MCLK = 512 kHz
0	1							MCLK = 1.536 or 1.544 MHz
1	0							MCLK = 2.048 MHz (Note 4)
1	1							MCLK = 4.096 MHz
		0	X					Select μ 255 law (Note 4)
		1	0					A-law, Including Even
		1	1					Bit Inversion
				0				A-law, No Even Bit Inversion
				1				Delayed Data Timing
					0	0		Non-Delayed Data Timing (Note 4)
					1	X		Normal Operation (Note 4)
					0	1		Digital Loopback
							0	Analog Loopback
							0	Power Amp Enabled in PDN
							1	Power Amp Disabled in PDN (Note 4)

Note 4: State at power-on initialization. (Bit 4 = 0)

2.1 Master Clock Frequency Selection

A Master clock must be provided to COMBO II for operation of the filter and coding/decoding functions. The MCLK frequency must be either 512 kHz, 1.536 MHz, 1.544 MHz, 2.048 MHz, or 4.096 MHz and must be synchronous with BCLK. Bits F_1 and F_0 (see *Table 2*) must be set during initialization to select the correct internal divider.

2.2 Coding Law Selection

Bits "MA" and "IA" in *Table 2* permit the selection of μ 255 coding or A-law coding, with or without even bit inversion.

2.3 Analog Loopback

Analog Loopback mode is entered by setting the "AL" and "DL" bits in the Control Register as shown in *Table 2*. In the analog loopback mode, the Transmit input VF_{xI} is isolated from the input pin and internally connected to the VF_{xO} output, forming a loop from the Receive PCM Register back to the Transmit PCM Register. The VF_{xO} pin remains active, and the programmed settings of the Transmit and Receive

gains remain unchanged, thus care must be taken to ensure that overload levels are not exceeded anywhere in the loop. Hybrid balance must be disabled for meaningful analog loopback function.

2.4 Digital Loopback

Digital Loopback mode is entered by setting the "AL" and "DL" bits in the Control Register as shown in *Table 2*. This mode provides another stage of path verification by enabling data written into the Receive PCM Register to be read back from that register in any Transmit time-slot at $D_{x0}/1$. In digital loopback, the decoder will remain functional and output a signal at VF_{xO} . If this is undesirable, the receive output can be turned off by programming the receive gain register to all zeros.

3.0 INTERFACE LATCH DIRECTIONS

Immediately following power-on, all Interface Latches assume they are inputs, and therefore all IL pins are in a high impedance state. Each IL pin may be individually programmed as a logic input or output by writing the appropriate instruction to the LDR, see *Table 1* and *Table 3*. For minimum power dissipation, unconnected latch pins should be programmed as outputs. For the TP3071, L5 should always be programmed as an output.

Bits L_5-L_0 must be set by writing the specified instruction to the LDR with the L bits in the second byte set as follows:

TABLE 3. Byte 2 Functions of Latch Direction Register

Byte 2 Bit Number							
7	6	5	4	3	2	1	0
L_0	L_1	L_2	L_3	L_4	L_5	X	X
L_n Bit				IL Direction			
0				Input			
1				Output			

X = don't care

INTERFACE LATCH STATES

Interface Latches configured as outputs assume the state determined by the appropriate data bit in the 2-byte instruction written to the Interface Latch Register (ILR) as shown in *Table 1* and *Table 4*. Latches configured as inputs will sense the state applied by an external source, such as the Off-Hook detect output of a SLIC. All bits of the ILR, i.e. sensed inputs and the programmed state of outputs, can be read back in the 2nd byte of a READ from the ILR.

It is recommended that during initialization, the state of IL pins to be configured as outputs should be programmed first, followed immediately by the Latch Direction Register.

TABLE 4. Interface Latch Data Bit Order

Bit Number							
7	6	5	4	3	2	1	0
D_0	D_1	D_2	D_3	D_4	D_5	X	X

Programmable Functions (Continued)

TABLE 5. Coding Law Conventions

	μ 255 law		True A-law with even bit inversion		A-law without even bit inversion	
	MSB	LSB	MSB	LSB	MSB	LSB
$V_{IN} = +\text{Full Scale}$	1	0	0	1	0	1
$V_{IN} = 0V$	1	1	1	1	1	1
	0	1	1	1	1	1
$V_{IN} = -\text{Full Scale}$	0	0	0	0	0	0

Note 5: The MSB is always the first PCM bit shifted in or out of COMBO II.

TABLE 6. Time-Slot and Port Assignment Instruction

Bit Number and Name								Function
7	6	5	4	3	2	1	0	
EN	PS (Note 6)	T_5 (Note 7)	T_4	T_3	T_2	T_1	T_0	
0	0	X	X	X	X	X	X	Disable D_{X0} Output (Transmit Instruction) Disable D_{R0} Input (Receive Instruction)
0	1	X	X	X	X	X	X	Disable D_{X1} Output (Transmit Instruction) Disable D_{R1} Input (Receive Instruction)
1	0	Assign One Binary Coded Time-Slot from 0–63					Enable D_{X0} Output (Transmit Instruction) Enable D_{R0} Input (Receive Instruction)	
1	1	Assign One Binary Coded Time-Slot from 0–63					Enable D_{X1} Output (Transmit Instruction) Enable D_{R1} Input (Receive Instruction)	

Note 6: The "PS" bit MUST always be set to 0 for the TP3071.

Note 7: T_5 is the MSB of the Time-slot assignment bit field. Time slot bits should be set to "000000" for both transmit and receive when operating in non-delayed data timing mode.

5.0 TIME-SLOT ASSIGNMENT

COMBO II can operate in either fixed time-slot or time-slot assignment mode for selecting the Transmit and Receive PCM time-slots. Following power-on, the device is automatically in Non-Delayed Timing mode, in which the time-slot always begins with the leading (rising) edge of frame sync inputs FS_X and FS_R . Time-Slot Assignment may only be used with Delayed Data timing; see Figure 5. FS_X and FS_R may have any phase relationship with each other in BCLK period increments.

Alternatively, the internal time-slot assignment counters and comparators can be used to access any time-slot in a frame, using the frame sync inputs as marker pulses for the beginning of transmit and receive time-slot 0. In this mode, a frame may consist of up to 64 time-slots of 8 bits each. A time-slot is assigned by a 2-byte instruction as shown in Table 1 and Table 6. The last 6 bits of the second byte indicate the selected time-slot from 0–63 using straight binary notation. When writing a timeslot and port assignment register, if the PCM interface is currently active, it is immediately deactivated to prevent possible bus clashes. A new assignment becomes active on the second frame following the end of the Chip-Select for the second control byte. Rewriting of register contents should not be performed during the talking period of a connection to prevent waveform distortion caused by loss of a sample which will occur with each register write. The "EN" bit allows the PCM inputs, $D_{R0}/1$, or outputs, $D_{X0}/1$, as appropriate, to be enabled or disabled.

Time-Slot Assignment mode requires that the FS_X and FS_R pulses must conform to the delayed data timing format shown in Figure 5.

6.0 PORT SELECTION

On the TP3070 only, an additional capability is available; 2 Transmit serial PCM ports, D_{X0} and D_{X1} , and 2 Receive serial PCM ports, D_{R0} and D_{R1} , are provided to enable two-way space switching to be implemented. Port selections for transmit and receive are made within the appropriate time-slot assignment instruction using the "PS" bit in the second byte. The PS bit selects either Port 0 or Port 1. Both ports cannot be active at the same time.

On the TP3071, only ports D_{X0} and D_{R0} are available, therefore the "PS" bit MUST always be set to 0 for these devices.

Table 6 shows the format for the second byte of both transmit and receive time-slot and port assignment instructions.

7.0 TRANSMIT GAIN INSTRUCTION BYTE 2

The transmit gain can be programmed in 0.1 dB steps by writing to the Transmit Gain Register as defined in Table 1 and Table 7. This corresponds to a range of 0 dBm0 levels at V_{FX1} between 1.619 Vrms and 0.087 Vrms (equivalent to +6.4 dBm to -19.0 dBm in 600 Ω).

To calculate the binary code for byte 2 of this instruction for any desired input 0 dBm0 level in Vrms, take the nearest integer to the decimal number given by:

$$200 \times \log_{10} (V/0.08595)$$

Programmable Functions (Continued)

and convert to the binary equivalent. Some examples are given in *Table 7* and a complete tabulation is given in Appendix I of AN-614.

It should be noted that the Transmit (idle channel) Noise and Transmit Signal to Total Distortion are both specified with transmit gain set to 0 dB (Gain Register set to all ones). At high transmit gains there will be some degradation in noise performance for these parameters. See Application Note AN-614 for more information on this subject.

TABLE 7. Byte 2 of Transmit Gain Instruction

Bit Number 7 6 5 4 3 2 1 0	0 dBm0 Test Level (Vrms) at VF _{XI}
0 0 0 0 0 0 0 0	No Output (Note 8)
0 0 0 0 0 0 0 1	0.087
0 0 0 0 0 0 1 0	0.088
—	—
1 1 1 1 1 1 1 0	1.600
1 1 1 1 1 1 1 1	1.619

Note 8: Analog signal path is cut off, but D_X remains active and will output codes representing idle noise.

8.0 RECEIVE GAIN INSTRUCTION BYTE 2

The receive gain can be programmed in 0.1 dB steps by writing to the Receive Gain Register as defined in *Table 1* and *Table 8*. Note the following restrictions on output drive capability:

- 0 dBm0 levels ≤ 1.96 Vrms at VF_{RO} may be driven into a load of ≥ 15 k Ω to GND; receive gain set to 0 dB (Gain Register set to all ones)
- 0 dBm0 levels ≤ 1.85 Vrms at VF_{RO} may be driven into a load of $\geq 600\Omega$ to GND; receive gain set to -0.5 dB
- 0 dBm0 levels ≤ 1.71 Vrms at VF_{RO} may be driven into a load of $\geq 300\Omega$ to GND; receive gain set to -1.2 dB

To calculate the binary code for byte 2 of this instruction for any desired output 0 dBm0 level in Vrms, take the nearest integer to the decimal number given by:

$$200 \times \log_{10} (V/0.1043)$$

and convert to the binary equivalent. Some examples are given in *Table 8* and a complete tabulation is given in Appendix I of AN-614.

TABLE 8. Byte 2 of Receive Gain Instruction

Bit Number 7 6 5 4 3 2 1 0	0 dBm0 Test Level (Vrms) at VF _{RO}
0 0 0 0 0 0 0 0	No Output (Low Z to GND)
0 0 0 0 0 0 0 1	0.105
0 0 0 0 0 0 1 0	0.107
—	—
1 1 1 1 1 1 1 0	1.941
1 1 1 1 1 1 1 1	1.964

9.0 HYBRID BALANCE FILTER

The Hybrid Balance Filter on COMBO II is a programmable filter consisting of a second-order section, Hybal1, followed by a first-order section, Hybal2, and a programmable attenu-

ator. Either of the filter sections can be bypassed if only one is required to achieve good cancellation. A selectable 180 degree inverting stage is included to compensate for interface circuits which also invert the transmit input relative to the receive output signal. The 2nd order section is intended mainly to balance low frequency signals across a transformer SLIC, and the first order section to balance midrange to higher audio frequency signals.

As a 2nd order section, Hybal1 has a pair of low frequency zeroes and a pair of complex conjugate poles. When configuring Hybal1, matching the phase of the hybrid at low to mid-band frequencies is most critical. Once the echo path is correctly balanced in phase, the magnitude of the cancellation signal can be corrected by the programmable attenuator.

The 2nd order mode of Hybal1 is most suitable for balancing interfaces with transformers having high inductance of 1.5 Henries or more. An alternative configuration for smaller transformers is available by converting Hybal1 to a simple first-order section with a single real low-frequency pole and zero. In this mode, the pole/zero frequency may be programmed.

Many line interfaces can be adequately balanced by use of the Hybal1 section only, in which case the Hybal2 filter should be de-selected to bypass it.

Hybal2, the higher frequency first-order section, is provided for balancing an electronic SLIC, and is also helpful with a transformer SLIC in providing additional phase correction for mid and high-band frequencies, typically 1 kHz to 3.4 kHz. Such a correction is particularly useful if the test balance impedance includes a capacitor of 100 nF or less, such as the loaded and non-loaded loop test networks in the United States. Independent placement of the pole and zero location is provided.

Figure 2 shows a simplified diagram of the local echo path for a typical application with a transformer interface. The magnitude and phase of the local echo signal, measured at VF_{XI}, are a function of the termination impedance Z_T, the line transformer and the impedance of the 2W loop, Z_L. If the impedance reflected back into the transformer primary is expressed as Z_{L'} then the echo path transfer function from VF_{RO} to VF_{XI} is:

$$H(w) = Z_L' / (Z_T + Z_L') \quad (1)$$

9.1 PROGRAMMING THE FILTER

On initial power-up, the Hybrid Balance filter is disabled. Before the hybrid balance filter can be programmed it is necessary to design the transformer and termination impedance in order to meet system 2W input return loss specifications, which are normally measured against a fixed test impedance (600 or 900 Ω in most countries). Only then can the echo path be modeled and the hybrid balance filter programmed. Hybrid balancing is also measured against a fixed test impedance, specified by each national Telecom administration to provide adequate control of talker and listener echo over the majority of their network connections. This test impedance is Z_L in *Figure 2*. The echo signal and the degree of transhybrid loss obtained by the programmable filter must be measured from the PCM digital input, D_{RO}, to the PCM digital output, D_{XO}, either by digital test signal analysis or by conversion back to analog by a PCM CODEC/Filter.

Programmable Functions (Continued)

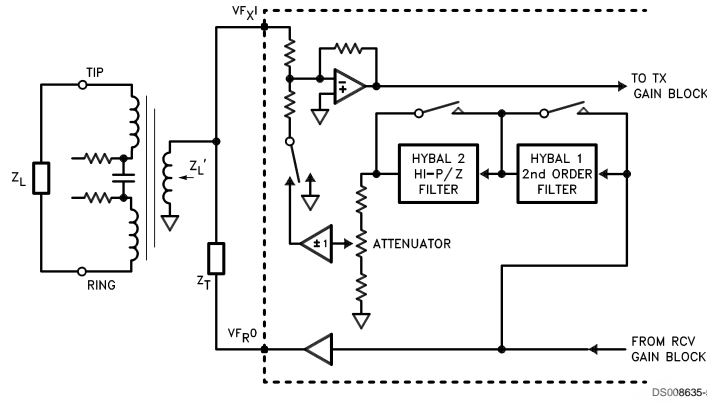

FIGURE 2. Simplified Diagram of Hybrid Balance Circuit

Three registers must be programmed in COMBO II to fully configure the Hybrid Balance Filter as follows:

- Register 1: select/de-select Hybrid Balance Filter;
invert/non-invert cancellation signal;
select/de-select Hybal2 filter section;
attenuator setting.
- Register 2: select/de-select Hybal1 filter;
set Hybal1 to 2nd order or 1st order;
pole and zero frequency selection.
- Register 3: program pole frequency in Hybal2 filter;
program zero frequency in Hybal2 filter.

Standard filter design techniques may be used to model the echo path (see Equation (1)) and design a matching hybrid balance filter configuration. Alternatively, the frequency response of the echo path can be measured and the hybrid balance filter designed to replicate it.

A Hybrid Balance filter design guide and software optimization program are available under license from National Semiconductor Corporation; order TP3077SW.

Applications Information

Figure 3 shows a typical application of the TP3071 together with a typical monolithic SLIC. Four of the IL latches are configured as outputs to control the relay drivers on the SLIC, while IL4 is an input for the Supervision signal.

POWER SUPPLIES

While the pins of the TP3070 COMBO II devices are well protected against electrical misuse, it is recommended that the standard CMOS practice of applying GND to the device before any other connections are made should always be followed. In applications where the printed circuit card may be plugged into a hot socket with power and clocks already present, extra long pins on the connector should be used for ground and V_{BB} . In addition, a Schottky diode should be connected between V_{BB} and ground.

To minimize noise sources, all ground connections to each device should meet at a common point as close as possible to the device GND pin in order to prevent the interaction of ground return currents flowing through a common bus impedance. Power supply decoupling capacitors of 0.1 μF should be connected from this common device ground point to V_{CC} and V_{BB} as close to the device pins as possible. V_{CC} and V_{BB} should also be decoupled with Low Effective Series Resistance Capacitors of at least 10 μF located near the card edge connector.

Further guidelines on PCB layout techniques are provided in Application Note AN-614, "COMBO II™ Programmable PCM CODEC/Filter Family Application Guide".

Applications Information (Continued)

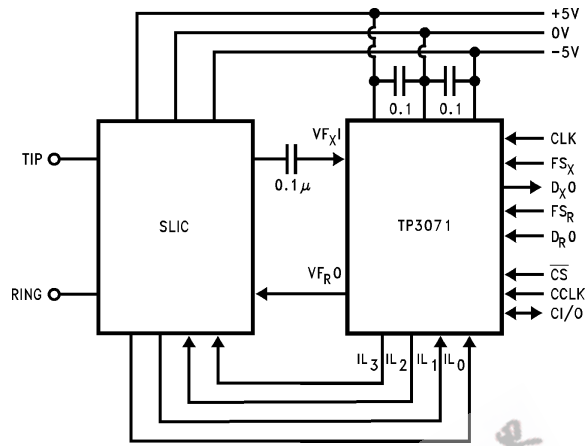

FIGURE 3. Typical Application with Monolithic SLIC

DS008635-7

EEPW.com.cn 电子产业世界

Absolute Maximum Ratings (Note 9)

If Military/Aerospace specified devices are required, please contact the National Semiconductor Sales Office/Distributors for availability and specifications.

V_{CC} to GND	7V
Voltage at V_{FXI}	$V_{CC} + 0.5V$ to $V_{BB} - 0.5V$
Voltage at any Digital Input	$V_{CC} + 0.5V$ to GND - 0.5V

Storage Temperature Range	-65°C to +150°C
V_{BB} to GND	-7V
Current at V_{FR0}	±100 mA
Current at any Digital Output	±50 mA
Lead Temperature (Soldering, 10 sec.)	300°C

Electrical Characteristics

Unless otherwise noted, limits printed in **BOLD** characters are guaranteed for $V_{CC} = +5V \pm 5\%$, $V_{BB} = -5V \pm 5\%$, $T_A = 0^\circ C$ to $+70^\circ C$ ($-40^\circ C$ to $+85^\circ C$ for TP3070-X) by correlation with 100% electrical testing at $T_A = 25^\circ C$. All other limits are assured by correlation with other production tests and/or product design and characterization. All signals referred to GND. Typicals specified at $V_{CC} = +5V$, $V_{BB} = -5V$, $T_A = 25^\circ C$.

Symbol	Parameter	Conditions	Min	Typ	Max	Units
DIGITAL INTERFACES						
V_{IL}	Input Low Voltage	All Digital Inputs (DC Meas.) (Note 10)			0.7	V
V_{IH}	Input High Voltage	All Digital Inputs (DC Meas.) (Note 10)	2.0			V
V_{OL}	Output Low Voltage	D_x0 , D_x1 , \overline{TS}_x0 , \overline{TS}_x1 and CO, $I_L = 3.2$ mA, All Other Digital Outputs, $I_L = 1$ mA			0.4	V
V_{OH}	Output High Voltage	D_x0 , D_x1 and CO, $I_L = -3.2$ mA, All Other Digital Outputs (except \overline{TS}_x), $I_L = -1$ mA	2.4			V
		All Digital Outputs, $I_L = -100$ μA	$V_{CC} - 0.5$			V
I_{IL}	Input Low Current	Any Digital Input, $GND < V_{IN} < V_{IL}$	-10		10	μA
I_{IH}	Input High Current	Any Digital Input except MR, $V_{IH} < V_{IN} < V_{CC}$	-10		10	μA
		MR Only	-10		100	μA
I_{OZ}	Output Current in High Impedance State (TRI-STATE)	D_x0 , D_x1 , \overline{TS}_x0 , \overline{TS}_x1 , CO and CI/O (as an Output) IL5-IL0 When Selected as Inputs $GND < V_{OUT} < V_{CC}$	-10		10	μA
		-40°C to +85°C (TP3070-X)	-30		30	μA
ANALOG INTERFACES						
I_{VFXI}	Input Current, V_{FXI}	$-3.3V < V_{FXI} < 3.3V$	-10.0		10.0	μA
R_{VFXI}	Input Resistance	$-3.3V < V_{FXI} < 3.3V$	390	620		k Ω
V_{OSX}	Input Offset Voltage Applied at V_{FXI}	Transmit Gain = 0 dB			200	mV
		Transmit Gain = 25.4 dB			10	mV
R_{LVFRO}	Load Resistance	Receive Gain = 0 dB	15k			Ω
		Receive Gain = -0.5 dB	600			
		Receive Gain = -1.2 dB	300			
CL_{VFRO}	Load Capacitance	$R_{LVFRO} \geq 300\Omega$ CL_{VFRO} from V_{FR0} to GND			200	pF
RO_{VFRO}	Output Resistance	Steady Zero PCM Code Applied to D_R0 or D_R1		1.0	3.0	Ω
V_{OSR}	Output Offset Voltage at V_{FRO}	Alternating \pm Zero PCM Code Applied to D_R0 or D_R1 , Maximum Receive Gain	-200		200	mV
POWER DISSIPATION						
I_{CC0}	Power Down Current	CCLK, CI/O, CI, CO, = 0.4V, $\overline{CS} = 2.4V$ Interface Latches Set as Outputs with No Load, All Other Inputs Active, Power Amp Disabled		0.1	0.6	mA
I_{BB0}	Power Down Current	As Above		-0.1	-0.3	mA
		-40°C to +85°C (TP3070-X)			-0.4	mA
I_{CC1}	Power Up Current	CCLK, CI/O, CI, CO = 0.4V, $\overline{CS} = 2.4V$ No Load on Power Amp Interface Latches Set as Outputs with No Load		8.0	11.0	mA
		-40°C to +85°C (TP3070-X)			13.0	mA

Electrical Characteristics (Continued)

Unless otherwise noted, limits printed in **BOLD** characters are guaranteed for $V_{CC} = +5V \pm 5\%$, $V_{BB} = -5V \pm 5\%$; $T_A = 0^\circ C$ to $+70^\circ C$ ($-40^\circ C$ to $+85^\circ C$ for TP3070-X) by correlation with 100% electrical testing at $T_A = 25^\circ C$. All other limits are assured by correlation with other production tests and/or product design and characterization. All signals referenced to GND. Typicals specified at $V_{CC} = +5V$, $V_{BB} = -5V$, $T_A = 25^\circ C$.

Symbol	Parameter	Conditions	Min	Typ	Max	Units
POWER DISSIPATION						
I_{BB1}	Power Up Current	As Above $-40^\circ C$ to $+85^\circ C$ (TP3070-X)		-8.0	-11.0 -13.0	mA mA
I_{CC2}	Power Down Current	Power Amp Enabled $-40^\circ C$ to $+85^\circ C$ (TP3070-X)		2.0	3.0 4.0	mA mA
I_{BB2}	Power Down Current	Power Amp Enabled $-40^\circ C$ to $+85^\circ C$ (TP3070-X)		-2.0	-3.0 -4.0	mA mA

Note 9: "Absolute Maximum Ratings" indicate limits beyond which damage to the device may occur. Operating Ratings indicate conditions for which the device is functional, but do not guarantee specific performance limits.

Note 10: See definitions and timing conventions section.

Timing Specifications

Unless otherwise noted, limits printed in **BOLD** characters are guaranteed for $V_{CC} = +5V \pm 5\%$; $V_{BB} = -5V \pm 5\%$; $T_A = 0^\circ C$ to $+70^\circ C$ ($-40^\circ C$ to $+85^\circ C$ for TP3070-X) by correlation with 100% electrical testing at $T_A = 25^\circ C$. All other limits are assured by correlation with other production tests and/or product design and characterization. All signals referenced to GND. Typicals specified at $V_{CC} = +5V$, $V_{BB} = -5V$, $T_A = 25^\circ C$.
All timing parameters are measured at $V_{OH} = 2.0V$ and $V_{OL} = 0.7V$.
See Definitions and Timing Conventions section for test methods information.

Symbol	Parameter	Conditions	Min	Typ	Max	Units
MASTER CLOCK TIMING						
f_{MCLK}	Frequency of MCLK	Selection of Frequency is Programmable (See Table 5)		512 1536 1544 2048 4096		kHz kHz kHz kHz kHz
t_{WMH}	Period of MCLK High	Measured from V_{IH} to V_{IH} (Note 11)	80			ns
t_{WML}	Period of MCLK Low	Measured from V_{IL} to V_{IL} (Note 11)	80			ns
t_{RM}	Rise Time of MCLK	Measured from V_{IL} to V_{IH}			30	ns
t_{FM}	Fall Time of MCLK	Measured from V_{IH} to V_{IL}			30	ns
t_{HBM}	HOLD Time, BCLK LOW to MCLK HIGH	TP3070 Only	50			ns
t_{WFL}	Period of F_{SX} or F_{SR} Low	Measured from V_{IL} to V_{IL}	1			MCLK Period
PCM INTERFACE TIMING						
f_{BCLK}	Frequency of BCLK	May Vary from 64 kHz to 4096 kHz in 8 kHz Increments	64		4096	kHz
t_{WBH}	Period of BCLK High	Measured from V_{IH} to V_{IH}	80			ns
t_{WBL}	Period of BCLK Low	Measured from V_{IL} to V_{IL}	80			ns
t_{RB}	Rise Time of BCLK	Measured from V_{IL} to V_{IH}			30	ns
t_{FB}	Fall Time of BCLK	Measured from V_{IH} to V_{IL}			30	ns
t_{HBF}	Hold Time, BCLK Low to $FS_{X/R}$ High or Low		30			ns
t_{SFB}	Setup Time, $FS_{X/R}$ High to BCLK Low		30			ns
t_{DBD}	Delay Time, BCLK High to Data Valid	Load = 100 pF Plus 2 LSTTL Loads $-40^\circ C$ to $+85^\circ C$ (TP3070-X)			80 90	ns ns

Timing Specifications (Continued)

Unless otherwise noted, limits printed in **BOLD** characters are guaranteed for $V_{CC} = +5V \pm 5\%$; $V_{BB} = -5V \pm 5\%$; $T_A = 0^\circ\text{C}$ to $+70^\circ\text{C}$ (-40°C to $+85^\circ\text{C}$ for TP3070-X) by correlation with 100% electrical testing at $T_A = 25^\circ\text{C}$. All other limits are assured by correlation with other production tests and/or product design and characterization. All signals referenced to GND. Typicals specified at $V_{CC} = +5V$, $V_{BB} = -5V$, $T_A = 25^\circ\text{C}$.

All timing parameters are measured at $V_{OH} = 2.0V$ and $V_{OL} = 0.7V$.

See Definitions and Timing Conventions section for test methods information.

Symbol	Parameter	Conditions	Min	Typ	Max	Units
PCM INTERFACE TIMING						
t_{DBZ}	Delay Time, BCLK Low to $D_{x0/1}$ Disabled if FS_x Low, FS_x Low to $D_{x0/1}$ disabled if 8th BCLK Low, or BCLK High to $D_{x0/1}$ Disabled if FS_x High	$D_{x0/1}$ Disabled is measured at V_{OL} or V_{OH} according to <i>Figure 4</i> or <i>Figure 5</i> -40°C to $+85^\circ\text{C}$ (TP3070-X)	15 15		80 100	ns ns
t_{DBT}	Delay Time, BCLK High to \overline{TS}_x Low if FS_x High, or FS_x High to \overline{TS}_x Low if BCLK High (Non Delayed Mode); BCLK High to \overline{TS}_x Low (Delayed Data Mode)	Load = 100 pF Plus 2 LSTTL Loads			60	ns
t_{ZBT}	TRI-STATE Time, BCLK Low to \overline{TS}_x High if FS_x Low, FS_x Low to \overline{TS}_x High if 8th BCLK Low, or BCLK High to \overline{TS}_x High if FS_x High		15		60	ns
t_{DFD}	Delay Time, $FS_{x/R}$ High to Data Valid	Load = 100 pF Plus 2 LSTTL Loads, Applies if $FS_{x/R}$ Rises Later than BCLK Rising Edge in Non-Delayed Data Mode Only -40°C to $+85^\circ\text{C}$ (TP3070-X)			80 90	ns ns
t_{SDB}	Setup Time, $D_{R0/1}$ Valid to BCLK Low		30			ns
t_{HBD}	Hold Time, BCLK Low to $D_{R0/1}$ Invalid	-40°C to $+85^\circ\text{C}$ (TP3070-X)	15 15			ns ns
SERIAL CONTROL PORT TIMING						
f_{CCLK}	Frequency of CCLK				2048	kHz
t_{WCH}	Period of CCLK High	Measured from V_{IH} to V_{IH}	160			ns
t_{WCL}	Period of CCLK Low	Measured from V_{IL} to V_{IL}	160			ns
t_{RC}	Rise Time of CCLK	Measured from V_{IL} to V_{IH}			50	ns
t_{FC}	Fall Time of CCLK	Measured from V_{IH} to V_{IL}			50	ns
t_{HCS}	Hold Time, CCLK Low to \overline{CS} Low	CCLK1	10			ns
t_{HSC}	Hold Time, CCLK Low to \overline{CS} High	CCLK 8	100			ns
t_{SSC}	Setup Time, \overline{CS} Transition to CCLK Low		60			ns
t_{SSCO}	Setup Time, \overline{CS} Transition to CCLK High		50			ns
t_{SDC}	Setup Time, CI (CI/O) Data In to CCLK Low		50			ns
t_{HCD}	Hold Time, CCLK Low to CI/O Invalid		50			ns
t_{DCD}	Delay Time, CCLK High to CI/O Data Out Valid	Load = 100 pF plus 2 LSTTL Loads -40°C to $+85^\circ\text{C}$ (TP3070-X)			80 100	ns ns

Timing Specifications (Continued)

Unless otherwise noted, limits printed in **BOLD** characters are guaranteed for $V_{CC} = +5V \pm 5\%$; $V_{BB} = -5V \pm 5\%$; $T_A = 0^\circ\text{C}$ to $+70^\circ\text{C}$ (-40°C to $+85^\circ\text{C}$ for TP3070-X) by correlation with 100% electrical testing at $T_A = 25^\circ\text{C}$. All other limits are assured by correlation with other production tests and/or product design and characterization. All signals referenced to GND. Typicals specified at $V_{CC} = +5V$, $V_{BB} = -5V$, $T_A = 25^\circ\text{C}$. All timing parameters are measured at $V_{OH} = 2.0V$ and $V_{OL} = 0.7V$. See Definitions and Timing Conventions section for test methods information.

Symbol	Parameter	Conditions	Min	Typ	Max	Units
SERIAL CONTROL PORT TIMING						
t_{DSD}	Delay Time, \overline{CS} Low to CO (CI/O) Valid	Applies Only if Separate \overline{CS} used for Byte 2 -40°C to +85°C (TP3070-X)			80 100	ns
t_{DDZ}	Delay Time, \overline{CS} or 9th CCLK High to CO (CI/O) High Impedance	Applies to Earlier of \overline{CS} High or 9th CCLK High	15		80	ns
INTERFACE LATCH TIMING						
t_{SLC}	Setup Time, IL to CCLK 8 of Byte 1	Interface Latch Inputs Only	100			ns
t_{HCL}	Hold Time, IL Valid from 8th CCLK Low (Byte 1)		50			ns
t_{DCL}	Delay Time CCLK 8 of Byte 2 to IL	Interface Latch Outputs Only $C_L = 50\text{ pF}$			200	ns
MASTER RESET PIN						
t_{WMR}	Duration of Master Reset High		1			μs

Note 11: Applies only to MCLK Frequencies $\geq 1.536\text{ MHz}$. At 512 kHz a 50:50 $\pm 2\%$ Duty Cycle must be used.

Timing Diagrams

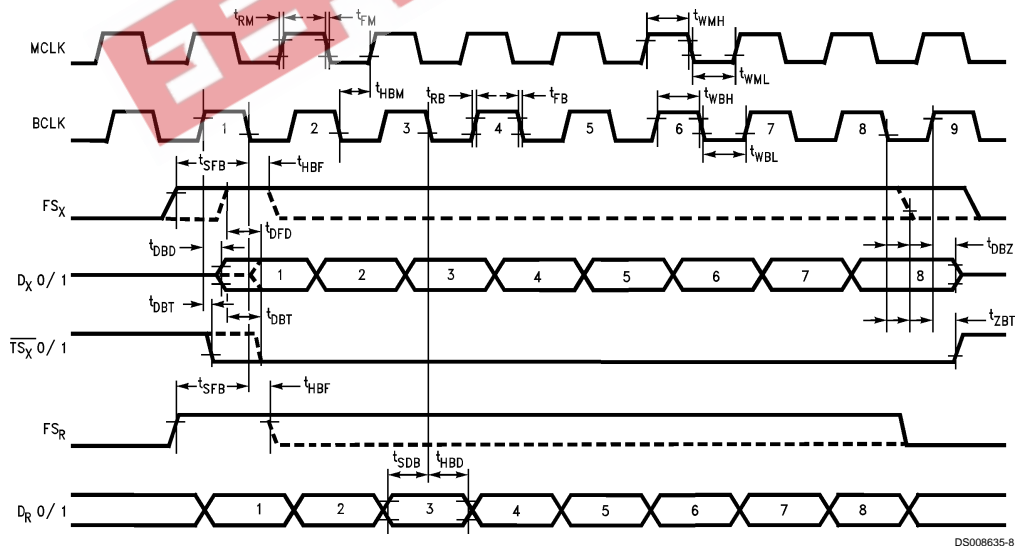

FIGURE 4. Non Delayed Data Timing Mode

DS008635-8

Timing Diagrams (Continued)

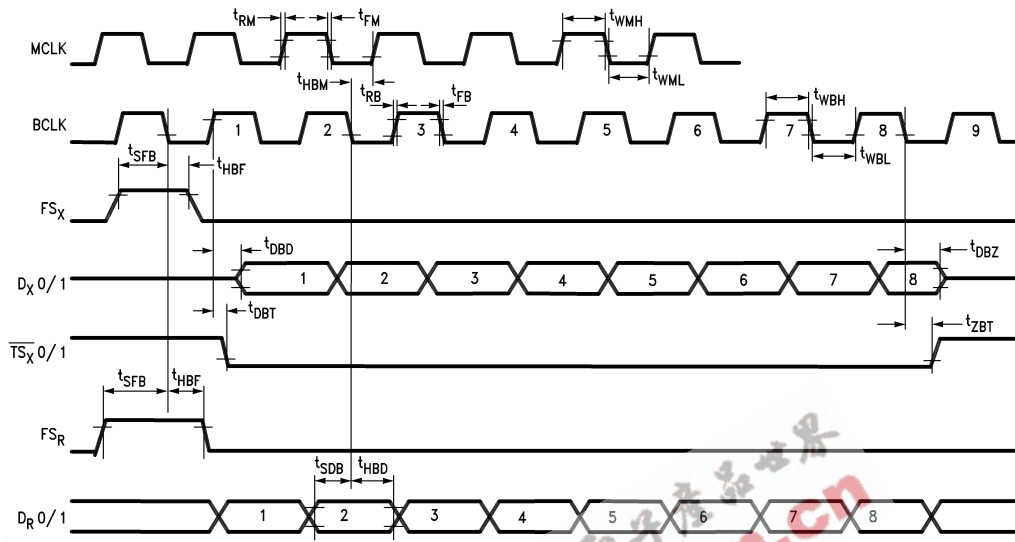

FIGURE 5. Delayed Data Timing Mode
(Time Slot Zero Only)

DS008635-9

Transmission Characteristics (Continued)

Unless otherwise noted, limits printed in **BOLD** characters are guaranteed for $V_{CC} = +5V \pm 5\%$, $V_{BB} = -5V \pm 5\%$; $T_A = 0^\circ C$ to $+70^\circ C$ ($-40^\circ C$ to $+85^\circ C$ for TP3070-X) by correlation with 100% electrical testing at $T_A = 25^\circ C$. $f = 1015.625$ Hz, $V_{F_X|I} = 0$ dBm0, D_{R0} or $D_{R1} = 0$ dBm0 PCM code. Transmit and receive gains programmed for maximum 0 dBm0 test levels (0 dB gain), hybrid balance filter disabled. All other limits are assured by correlation with other production tests and/or product design and characterization. All signals referenced to GND. Typical values specified at $V_{CC} = +5V$, $V_{BB} = -5V$, $T_A = 25^\circ C$.

Symbol	Parameter	Conditions	Min	Typ	Max	Units
AMPLITUDE RESPONSE						
G_{XAT}	Transmit Gain Variation with Temperature	Measured Relative to G_{XA} ; $V_{CC} = 5V$, $V_{BB} = -5V$, Minimum gain $< G_X <$ Maximum Gain $-40^\circ C$ to $+85^\circ C$ (TP3070-X)	-0.1		0.1	dB
			-0.15		0.15	dB
G_{XAL}	Transmit Gain Variation with Signal Level	Sinusoidal Test Method. Reference Level = 0 dBm0. $V_{F_X I} = -40$ dBm0 to $+3$ dBm0	-0.2		0.2	dB
		$V_{F_X I} = -50$ dBm0 to -40 dBm0	-0.4		0.4	dB
		$V_{F_X I} = -55$ dBm0 to -50 dBm0	-1.2		1.2	dB
G_{RA}	Receive Gain Absolute Accuracy	Receive Gain Programmed for Maximum 0 dBm0 Test Level (All 1's in Gain Register). Apply 0 dBm0 PCM Code to D_{R0} or D_{R1} . Measure $V_{F_R O}$. $T_A = 25^\circ C$	-0.15		0.15	dB
G_{RAG}	Receive Gain Variation with Programmed Gain	$T_A = 25^\circ C$, $V_{CC} = 5V$, $V_{BB} = -5V$ Programmed Gain from 0 dB to 19 dB (0 dBm0 Levels of 1.964 Vrms to 0.220 Vrms)	-0.1		0.1	dB
		Programmed Gain from 19.1 dB to 25.4 dB (0 dBm0 Levels of 0.218 Vrms to 0.105 Vrms) Note: ± 0.1 dB min/max is available as a selected part.	-0.3		0.3	dB
G_{RAT}	Receive Gain Variation with Temperature	Measured Relative to G_{RA} . $V_{CC} = 5V$, $V_{BB} = -5V$. Minimum Gain $< G_R <$ Maximum Gain $-40^\circ C$ to $+85^\circ C$ (TP3070-X)	-0.1		0.1	dB
			-0.15		0.15	dB
G_{RAF}	Receive Gain Variation with Frequency	Relative to 1015.625 Hz, (Note 15) D_{R0} or $D_{R1} = 0$ dBm0 code. Minimum Gain $< G_R <$ Maximum Gain				
		$f = 200$ Hz	-0.25		0.15	dB
		$f = 300$ Hz to 3000 Hz	-0.15		0.15	dB
		$f = 3400$ Hz	-0.7		0.0	dB
		$f = 4000$ Hz			-14	dB
		$G_R = 0$ dB, $D_{R0} = 0$ dBm0 Code, $G_X = 0$ dB (Note 15)				
		$f = 296.875$ Hz	-0.15		0.15	dB
		$f = 1875.00$ Hz	-0.15		0.15	dB
		$f = 2906.25$ Hz	-0.15		0.15	dB
		$f = 2984.375$ Hz	-0.15		0.15	dB
		$f = 3406.250$ Hz	-0.74		0.0	dB
$f = 3984.375$ Hz			-13.5	dB		

Transmission Characteristics (Continued)

Unless otherwise noted, limits printed in **BOLD** characters are guaranteed for $V_{CC} = +5V \pm 5\%$, $V_{BB} = -5V \pm 5\%$, $T_A = 0^\circ C$ to $+70^\circ C$ ($-40^\circ C$ to $+85^\circ C$ for TP3070-X) by correlation with 100% electrical testing at $T_A = 25^\circ C$. $f = 1015.625$ Hz, $V_{F_XI} = 0$ dBm0, D_{R0} or $D_{R1} = 0$ dBm0 PCM code. Transmit and receive gains programmed for maximum 0 dBm0 test levels (0 dB gain), hybrid balance filter disabled. All other limits are assured by correlation with other production tests and/or product design and characterization. All signals referenced to GND. Typical values specified at $V_{CC} = +5V$, $V_{BB} = -5V$, $T_A = 25^\circ C$.

Symbol	Parameter	Conditions	Min	Typ	Max	Units
AMPLITUDE RESPONSE						
G_{RAL}	Receive Gain Variation with Signal Level	Sinusoidal Test Method. Reference Level = 0 dBm0				
		$D_{R0} = -40$ dBm0 to $+3$ dBm0	-0.2		0.2	dB
		$D_{R0} = -50$ dBm0 to -40 dBm0	-0.4		0.4	dB
		$D_{R0} = -55$ dBm0 to -50 dBm0	-1.2		1.2	dB
		$D_{R0} = 3.1$ dBm0				
		$R_L = 600\Omega$, $G_R = -0.5$ dB	-0.2		0.2	dB
		$R_L = 300\Omega$, $G_R = -1.2$ dB	-0.2		0.2	dB
ENVELOPE DELAY DISTORTION WITH FREQUENCY						
D_{XA}	Tx Delay, Absolute	$f = 1600$ Hz			315	μs
D_{XR}	Tx Delay, Relative to D_{XA}	$f = 500-600$ Hz			220	μs
		$f = 600-800$ Hz			145	μs
		$f = 800-1000$ Hz			75	μs
		$f = 1000-1600$ Hz			40	μs
		$f = 1600-2600$ Hz			75	μs
		$f = 2600-2800$ Hz			105	μs
		$f = 2800-3000$ Hz			155	μs
D_{RA}	Rx Delay, Absolute	$f = 1600$ Hz			200	μs
D_{RR}	Rx Delay, Relative to D_{RA}	$f = 500-1000$ Hz	-40			μs
		$f = 1000-1600$ Hz	-30			μs
		$f = 1600-2600$ Hz			90	μs
		$f = 2600-2800$ Hz			125	μs
		$f = 2800-3000$ Hz			175	μs
NOISE						
N_{XC}	Transmit Noise, C Message Weighted, μ -law Selected	(Note 12) All '1's in Gain Register		12	15	dBrnC0
N_{XP}	Transmit Noise, P Message Weighted, A-law Selected	(Note 12) All '1's in Gain Register		-74	-67	dBm0p
N_{RC}	Receive Noise, C Message Weighted, μ -law Selected	PCM Code is Alternating Positive and Negative Zero		8	11	dBrnC0
N_{RP}	Receive Noise, P Message Weighted, A-law Selected	PCM Code Equals Positive Zero		-82	-79	dBm0p
N_{RS}	Noise, Single Frequency	$f = 0$ kHz to 100 kHz, Loop Around Measurement, $V_{F_XI} = 0$ Vrms			-53	dBm0
$PPSR_X$	Positive Power Supply Rejection, Transmit	$V_{CC} = 5.0$ V _{DC} + 100 mVrms $f = 0$ kHz-4 kHz (Note 13)	36			dB
		$f = 4$ kHz-50 kHz	30			dB
$NPSR_X$	Negative Power Supply Rejection, Transmit	$V_{BB} = -5.0$ V _{DC} + 100 mVrms $f = 0$ kHz-4 kHz (Note 13)	36			dB
		$f = 4$ kHz-50 kHz	30			dB

Transmission Characteristics (Continued)

Unless otherwise noted, limits printed in **BOLD** characters are guaranteed for $V_{CC} = +5V \pm 5\%$, $V_{BB} = -5V \pm 5\%$; $T_A = 0^\circ C$ to $+70^\circ C$ ($-40^\circ C$ to $+85^\circ C$ for TP3070-X) by correlation with 100% electrical testing at $T_A = 25^\circ C$. $f = 1015.625$ Hz, $V_{F_{X1}} = 0$ dBm0, D_{R0} or $D_{R1} = 0$ dBm0 PCM code. Transmit and receive gains programmed for maximum 0 dBm0 test levels (0 dB gain), hybrid balance filter disabled. All other limits are assured by correlation with other production tests and/or product design and characterization. All signals referenced to GND. Typical values specified at $V_{CC} = +5V$, $V_{BB} = -5V$, $T_A = 25^\circ C$.

Symbol	Parameter	Conditions	Min	Typ	Max	Units
NOISE						
PPSR _R	Positive Power Supply Rejection, Receive	PCM Code Equals Positive Zero $V_{CC} = 5.0 V_{DC} + 100$ mVrms Measure $V_{F_{R0}}$ $f = 0$ Hz–4000 Hz $f = 4$ kHz–25 kHz $f = 25$ kHz–50 kHz	36 40 36			dBC dB dB
NPSR _R	Negative Power Supply Rejection, Receive	PCM Code Equals Positive Zero $V_{BB} = -5.0 V_{DC} + 100$ mVrms Measure $V_{F_{R0}}$ $f = 0$ Hz–4000 Hz $f = 4$ kHz–25kHz $f = 25$ kHz–50 kHz	36 40 36			dBC dB dB
SOS	Spurious Out-of-Band Signals at the Channel Output	0 dBm0, 300 Hz to 3400 Hz Input PCM Code Applied at D_{R0} (or D_{R1}) 4600 Hz–7600 Hz 7600 Hz–8400 Hz 8400 Hz–50,000 Hz			-30 -40 -30	dB dB dB
DISTORTION						
STD _X	Signal to Total Distortion Transmit or Receive	Sinusoidal Test Method Level = 3.0 dBm0	33			dBC
STD _R	Half-Channel, μ -law Selected	= 0 dBm0 to -30 dBm0 = -40 dBm0 = -45 dBm0	36 30 25			dBC dBC dBC
STD _{RL}	Signal to Total Distortion Receive with Resistive Load	Sinusoidal Test Method Level = +3.1 dBm0 $R_L = 600\Omega$, $G_R = -0.5$ dB $R_L = 300\Omega$, $G_R = -1.2$ dB	33 33			dBC dBC
SFD _X	Single Frequency Distortion, Transmit				-46	dB
SFD _R	Single Frequency Distortion, Receive				-46	dB
IMD	Intermodulation Distortion	Transmit or Receive Two Frequencies in the Range 300 Hz–3400 Hz			-41	dB

Transmission Characteristics (Continued)

Unless otherwise noted, limits printed in **BOLD** characters are guaranteed for $V_{CC} = +5V \pm 5\%$, $V_{BB} = -5V \pm 5\%$; $T_A = 0^\circ C$ to $+70^\circ C$ ($-40^\circ C$ to $+85^\circ C$ for TP3070-X) by correlation with 100% electrical testing at $T_A = 25^\circ C$. $f = 1015.625$ Hz, $V_{FXI} = 0$ dBm0, D_{R0} or $D_{R1} = 0$ dBm0 PCM code. Transmit and receive gains programmed for maximum 0 dBm0 test levels (0 dB gain), hybrid balance filter disabled. All other limits are assured by correlation with other production tests and/or product design and characterization. All signals referenced to GND. Typical values specified at $V_{CC} = +5V$, $V_{BB} = -5V$, $T_A = 25^\circ C$.

Symbol	Parameter	Conditions	Min	Typ	Max	Units
CROSSTALK						
CT_{X-R}	Transmit to Receive Crosstalk, 0 dBm0 Transmit Level	$f = 300$ Hz–3400 Hz $D_R =$ Idle Code		-90	-75	dB
CT_{R-X}	Receive to Transmit Crosstalk, 0 dBm0 Receive Level	$f = 300$ Hz–3400 Hz (Note 13)		-90	-70	dB

Note 12: Measured by grounded input at VF_{XI} .

Note 13: $PPSR_X$, $NPSR_X$, and CT_{R-X} are measured with a -50 dBm0 activation signal applied to VF_{XI} .

Note 14: A signal is Valid if it is above V_{IH} or below V_{IL} and Invalid if it is between V_{IL} and V_{IH} . For the purposes of this specification the following conditions apply:

- All input signals are defined as: $V_{IL} = 0.4V$, $V_{IH} = 2.7V$, $t_R < 10$ ns, $t_F < 10$ ns.
- t_R is measured from V_{IL} to V_{IH} . t_F is measured from V_{IH} to V_{IL} .
- Delay Times are measured from the input signal Valid to the output signal Valid.
- Setup Times are measured from the data input Valid to the clock input Invalid.
- Hold Times are measured from the clock signal Valid to the data input Invalid.
- Pulse widths are measured from V_{IL} to V_{IL} or from V_{IH} to V_{IH} .

Note 15: A multi-tone test technique is used.

EEPW 电子产品世界 .com.cn

Definitions and Timing Conventions

DEFINITIONS

V_{IH}	V_{IH} is the D.C. input level above which an input level is guaranteed to appear as a logical one. This parameter is to be measured by performing a functional test at reduced clock speeds and nominal timing, (i.e., not minimum setup and hold times or output strobes), with the high level of all driving signals set to V_{IH} and maximum supply voltages applied to the device.
V_{IL}	V_{IL} is the D.C. input level below which an input level is guaranteed to appear as a logical zero to the device. This parameter is measured in the same manner as V_{IH} but with all driving signal low levels set to V_{IL} and minimum supply voltages applied to the device.
V_{OH}	V_{OH} is the minimum D.C. output level to which an output placed in a logical one state will converge when loaded at the maximum specified load current.
V_{OL}	V_{OL} is the maximum D.C. output level to which an output placed in a logical zero state will converge when loaded at the maximum specified load current.
Threshold Region	The threshold region is the range of input voltages between V_{IL} and V_{IH} .
Valid Signal	A signal is Valid if it is in one of the valid logic states, (i.e., above V_{IH} or below V_{IL}). In timing specifications, a signal is deemed valid at the instant it enters a valid state.
Invalid signal	A signal is invalid if it is not in a valid logic state, i.e., when it is in the threshold region between V_{IL} and V_{IH} . In timing specifications, a signal is deemed Invalid at the instant it enters the threshold region.

TIMING CONVENTIONS

For the purposes of this timing specification the following conventions apply.

Input Signals	All input signals may be characterized as: $V_L = 0.4V$, $V_H = 2.4V$, $t_R < 10$ ns, $t_F < 10$ ns.
Period	The period of the clock signal is designated as t_{Pxx} where xx represents the mnemonic of the clock signal being specified.
Rise Time	Rise times are designated as t_{Ryy} , where yy represents a mnemonic of the signal whose rise time is being specified. t_{Ryy} is measured from V_{IL} to V_{IH} .
Fall Time	Fall times are designated as t_{Fyy} , where yy represents a mnemonic of the signal whose fall time is being specified. t_{Fyy} is measured from V_{IH} to V_{IL} .
Pulse Width High	The high pulse width width is designated as t_{WzzH} , where zz represents the mnemonic of the input or output signal whose pulse width is being specified. High

pulse widths are measured from V_{IH} to V_{IH} .

Pulse Width Low	The low pulse width is designated as t_{WzzL} , where zz represents the mnemonic of the input or output signal whose pulse width is being specified. Low pulse widths are measured from V_{IL} to V_{IL} .
Setup Time	Setup times are designated as t_{Swwxx} , where ww represents the mnemonic of the input signal whose setup time is being specified relative to a clock or strobe input represented by mnemonic xx . Setup times are measured from the ww Valid to xx Invalid.
Hold Time	Hold times are designated as T_{Hwwxx} , where ww represents the mnemonic of the input signal whose hold time is being specified relative to a clock or strobe input represented by the mnemonic xx . Hold times are measured from xx Valid to ww Invalid.
Delay Time	Delay times are designated as $T_{Dxxyy}[IHIL]$, where xx represents the mnemonic of the input reference signal and yy represents the mnemonic of the output signal whose timing is being specified relative to xx . The mnemonic may optionally be terminated by an H or L to specify the high going or low going transition of the output signal. Maximum delay times are measured from xx Valid to yy Valid. Minimum delay times are measured from xx Valid to yy Invalid. This parameter is tested under the load conditions specified in the Conditions column of the Timing Specifications section of this datasheet.

EEPW 电子产品世界
.com.cn

Physical Dimensions inches (millimeters) unless otherwise noted

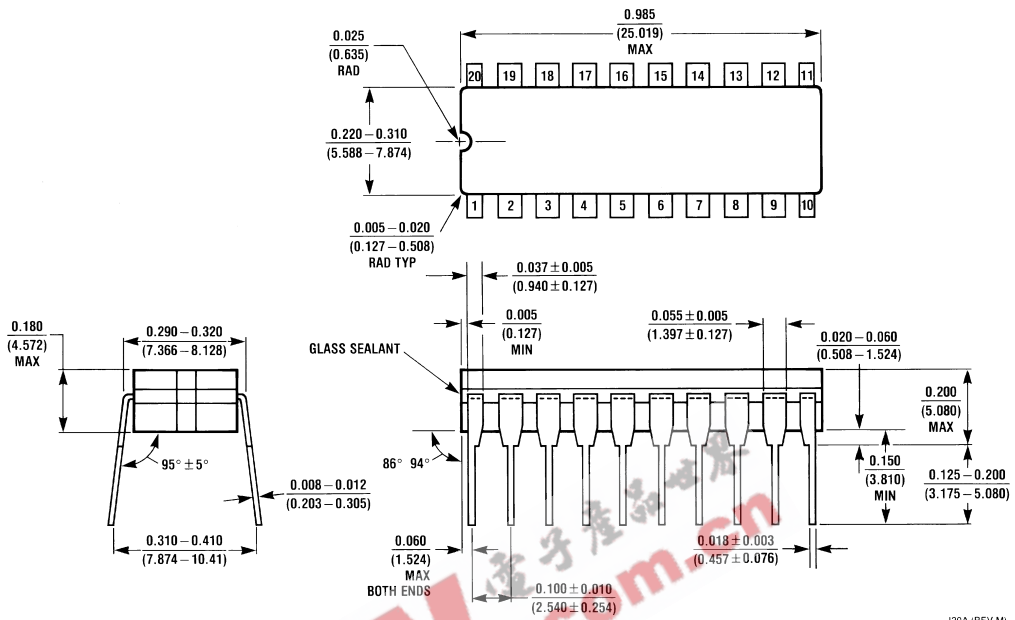

J20A (REV M)

Ceramic Dual-In-Line Package (J)
Order Number TP3071J
NS Package Number J20A

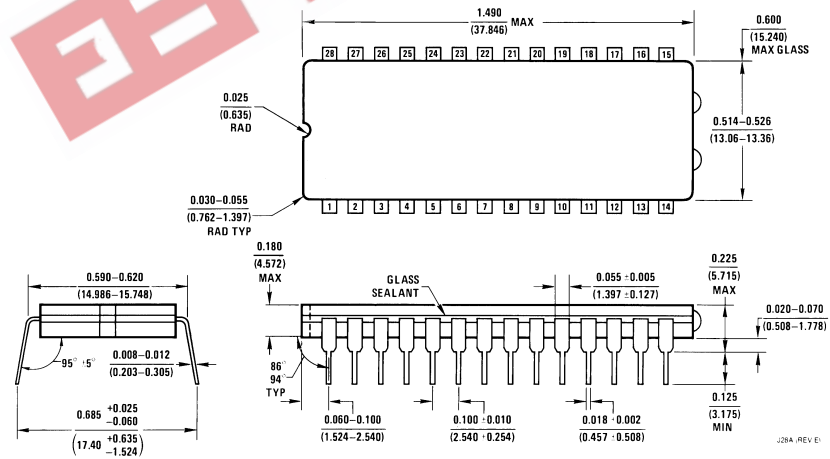

J28A (REV E)

Ceramic Dual-In-Line Package (J)
Order Number TP3070J
NS Package Number J28A

Physical Dimensions inches (millimeters) unless otherwise noted (Continued)

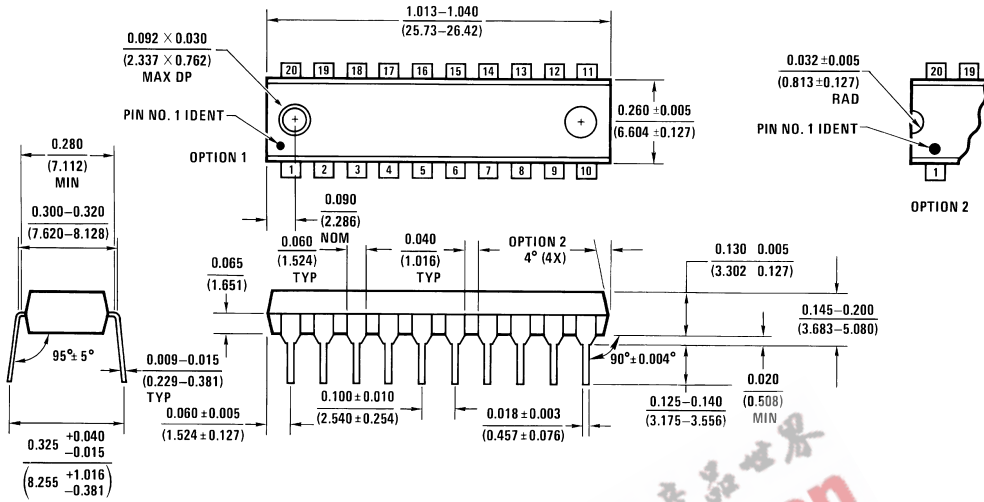

Molded Dual-In-Line Package (N)
 Order Number TP3071N
 NS Package Number N20A

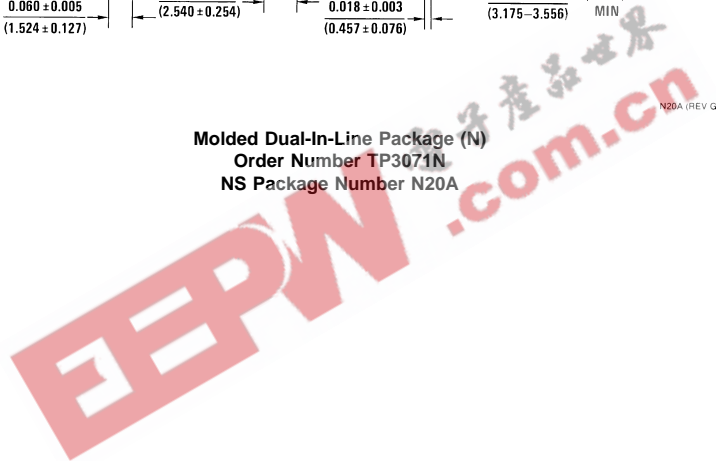

N20A (REV G)

Physical Dimensions inches (millimeters) unless otherwise noted (Continued)

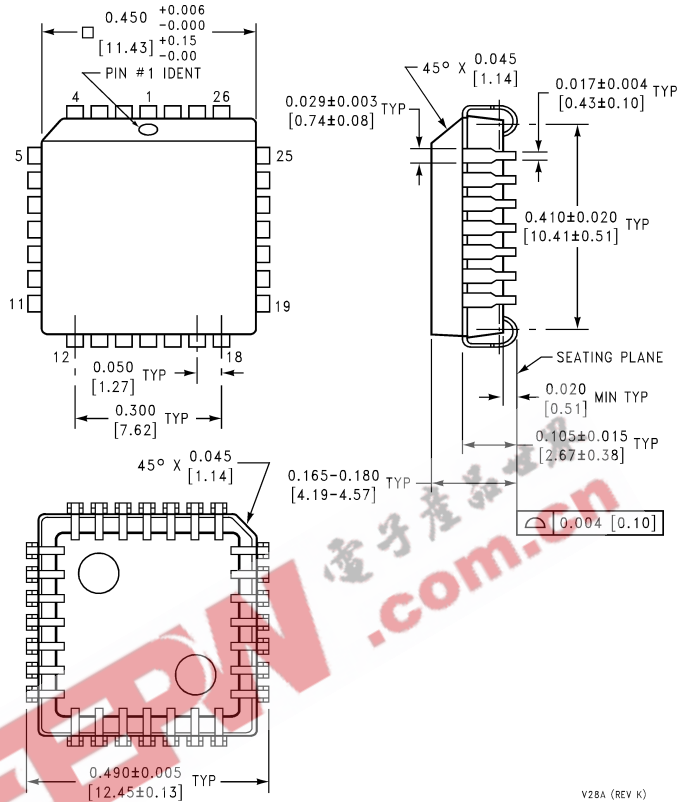

Plastic Leaded Chip Carrier (V)
Order Number TP3070V or TP3070V-X
NS Package Number V28A

V28A (REV K)

LIFE SUPPORT POLICY

NATIONAL'S PRODUCTS ARE NOT AUTHORIZED FOR USE AS CRITICAL COMPONENTS IN LIFE SUPPORT DEVICES OR SYSTEMS WITHOUT THE EXPRESS WRITTEN APPROVAL OF THE PRESIDENT OF NATIONAL SEMICONDUCTOR CORPORATION. As used herein:

1. Life support devices or systems are devices or systems which, (a) are intended for surgical implant into the body, or (b) support or sustain life, and whose failure to perform when properly used in accordance with instructions for use provided in the labeling can be reasonably expected to result in a significant injury to the user.
2. A critical component is any component of a life support device or system whose failure to perform can be reasonably expected to cause the failure of the life support device or system, or to affect its safety or effectiveness.



National Semiconductor Corporation
 Americas
 Tel: 1-800-272-9959
 Fax: 1-800-737-7018
 Email: support@nsc.com

National Semiconductor Europe
 Fax: +49 (0) 1 80-530 85 86
 Email: europe.support@nsc.com
 Deutsch Tel: +49 (0) 1 80-530 85 85
 English Tel: +49 (0) 1 80-532 78 32
 Français Tel: +49 (0) 1 80-532 93 58
 Italiano Tel: +49 (0) 1 80-534 16 80

National Semiconductor Asia Pacific Customer Response Group
 Tel: 65-2544466
 Fax: 65-2504466
 Email: sea.support@nsc.com

National Semiconductor Japan Ltd.
 Tel: 81-3-5639-7560
 Fax: 81-3-5639-7507

www.national.com