

## TP3040, TP3040A PCM Monolithic Filter

### General Description

The TP3040/TP3040A filter is a monolithic circuit containing both transmit and receive filters specifically designed for PCM CODEC filtering applications in 8 kHz sampled systems.

The filter is manufactured using microCMOS technology and switched capacitor integrators are used to simulate classical LC ladder filters which exhibit low component sensitivity.

#### TRANSMIT FILTER STAGE

The transmit filter is a fifth order elliptic low pass filter in series with a fourth order Chebyshev high pass filter. It provides a flat response in the passband and rejection of signals below 200 Hz and above 3.4 kHz.

#### RECEIVE FILTER STAGE

The receive filter is a fifth order elliptic low pass filter designed to reconstruct the voice signal from the decoded/demultiplexed signal which, as a result of the sampling process, is a stair-step signal having the inherent  $\sin x/x$  frequency response. The receive filter approximates the function required to compensate for the degraded frequency response and restore the flat passband response.

### Features

- Designed for D3/D4 and CCITT applications
- +5V, -5V power supplies
- Low power consumption:
  - 45 mW (0 dBm0 into 600 $\Omega$ )
  - 30 mW (power amps disabled)
- Power down mode: 0.5 mW
- 20 dB gain adjust range
- No external anti-aliasing components
- Sin  $x/x$  correction in receive filter
- 50/60 Hz rejection in transmit filter
- TTL and CMOS compatible logic
- All inputs protected against static discharge due to handling

### Block Diagram

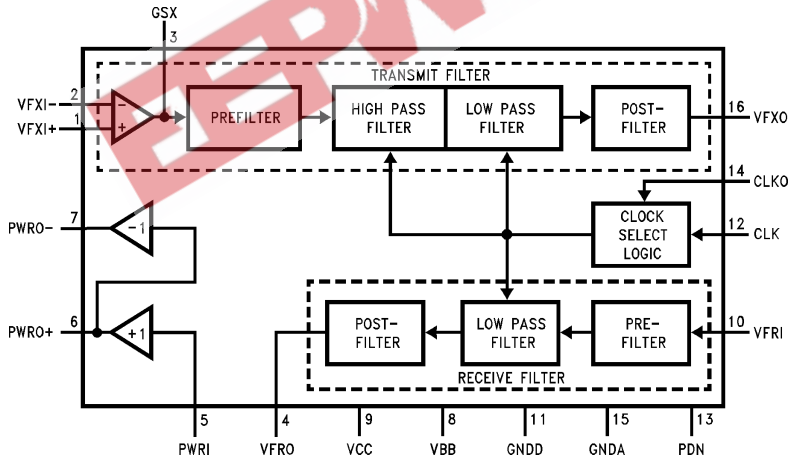

FIGURE 1

TL/H/6660-1

## Absolute Maximum Ratings

If Military/Aerospace specified devices are required, please contact the National Semiconductor Sales Office/Distributors for availability and specifications.

Supply Voltages	±7V
Power Dissipation	1 W/Package
Input Voltage	±7V
Voltage at Any Input or Output	$V_{CC} + 0.3V$ to $V_{BBV} - 0.3V$

Output Short-Circuit Duration	Continuous
Operating Temperature Range	-25°C to +125°C
Storage Temperature	-65°C to +150°C
Lead Temperature (Soldering, 10 seconds)	300°C
ESD Rating to be determined	

## DC Electrical Characteristics

Unless otherwise noted, limits printed in **BOLD** characters are guaranteed for  $V_{CC} = +5.0V \pm 5\%$ ,  $V_{BB} = -5.0V \pm 5\%$ ;  $T_A = 0^\circ C$  to  $70^\circ C$  by correlation with 100% electrical testing at  $T_A = 25^\circ C$ . All other limits are assured by correlation with other production tests and/or product design and characterization. Typicals specified at  $V_{CC} = +5.0V$ ,  $V_{BB} = -5.0V$ ,  $T_A = 25^\circ C$ . Clock frequency is 2.048 MHz. Digital interface voltages measured with respect to digital ground, GNDD. Analog voltages measured with respect to analog ground, GNDA.

Symbol	Parameter	Conditions	Min	Typ	Max	Units
<b>POWER DISSIPATION</b>						
$I_{CC0}$	$V_{CC}$ Standby Current	$V_{CC} = 5.25V$ , $V_{BB} = -5.25V$ , CLK0 and PWRI = $-5.25V$ (Note 6) All other pins at GND (0V) TP3040, TP3040A		50	<b>100</b>	$\mu A$
$I_{BB0}$	$V_{BB}$ Standby Current	$V_{CC} = 5.25V$ , $V_{BB} = -5.25V$ , CLK0 and PWRI = $-5.25V$ (Note 6) All other pins at GND (0V) TP3040, TP3040A		50	<b>100</b>	$\mu A$
$I_{CC1}$	$V_{CC}$ Operating Current	PWRI = $V_{BB}$ , Power Amp Inactive		3.0	<b>4.0</b>	mA
$I_{BB1}$	$V_{BB}$ Operating Current	PWRI = $V_{BB}$ , Power Amp Inactive		3.0	<b>4.0</b>	mA
$I_{CC2}$	$V_{CC}$ Operating Current	(Note 1)		4.6	<b>6.4</b>	mA
$I_{BB2}$	$V_{BB}$ Operating Current	(Note 1)		4.6	<b>6.4</b>	mA
<b>DIGITAL INTERFACE</b>						
$I_{INC}$	Input Current, CLK	$V_{BB} \leq V_{IN} \leq V_{CC}$	<b>-10</b>		<b>10</b>	$\mu A$
$I_{INP}$	Input Current, PDN	$V_{BB} \leq V_{IN} \leq V_{CC}$	<b>-100</b>			$\mu A$
$I_{IN0}$	Input Current, CLK0	$V_{BB} \leq V_{IN} \leq V_{CC} - 0.5V$	<b>-10</b>		<b>-0.1</b>	$\mu A$
$V_{IL}$	Input Low Voltage, CLK, PDN		0		<b>0.8</b>	V
$V_{IH}$	Input High Voltage, CLK, PDN		<b>2.2</b>		$V_{CC}$	V
$V_{ILO}$	Input Low Voltage, CLK0		$V_{BB}$		$V_{BB} + 0.5$	V
$V_{II0}$	Input Intermediate Voltage, CLK0		-0.8		0.8	V
$V_{IH0}$	Input High Voltage, CLK0		$V_{CC} - 0.5$		$V_{CC}$	V
<b>TRANSMIT INPUT OP AMP</b>						
$I_{BxI}$	Input Leakage Current, $V_{FxI}$	$-3.2V \leq V_{IN} \leq +3.2V$	<b>-100</b>		<b>100</b>	nA
$R_{IxI}$	Input Resistance, $V_{FxI}$	$V_{BB} \leq V_{FxI} \leq V_{CC}$	10			M $\Omega$
$V_{OSxI}$	Input Offset Voltage, $V_{FxI}$	$-2.5V \leq V_{IN} \leq +2.5V$	<b>-20</b>		<b>20</b>	mV
$V_{CM}$	Common-Mode Range, $V_{FxI}$		<b>-2.5</b>		<b>2.5</b>	V
CMRR	Common-Mode Rejection Ratio	$-2.5V \leq V_{IN} \leq 2.5V$	<b>60</b>			dB
PSRR	Power Supply Rejection of $V_{CC}$ or $V_{BB}$		<b>60</b>			dB
$R_{OL}$	Open Loop Output Resistance, $GS_x$			1		k $\Omega$
$R_L$	Minimum Load Resistance, $GS_x$		10			k $\Omega$
$C_L$	Maximum Load Capacitance, $GS_x$				100	pF
$VO_{xI}$	Output Voltage Swing, $GS_x$	$R_L \geq 10k$	<b>±2.5</b>			V
$A_{VOL}$	Open Loop Voltage Gain, $GS_x$	$R_L \geq 10k$	<b>5,000</b>			V/V
$F_c$	Open Loop Unity Gain Bandwidth, $GS_x$			2		MHz

## AC Electrical Characteristics

Unless otherwise specified,  $T_A = 25^\circ\text{C}$ . All parameters are specified for a signal level of 0 dBm0 at 1 kHz. The 0 dBm0 level is assumed to be 1.54 Vrms measured at the output of the transmit or receive filter. Limits printed in **BOLD** characters are guaranteed for  $V_{CC} = +5.0\text{V} \pm 5\%$ ,  $V_{BB} = -5.0\text{V} \pm 5\%$ ;  $T_A = 0^\circ\text{C}$  to  $70^\circ\text{C}$  by correlation with 100% electrical testing at  $T_A = 25^\circ\text{C}$ . All other limits are assured by correlation with other production tests and/or product design and characterization. Typicals specified at  $V_{CC} = +5.0\text{V}$ ,  $V_{BB} = -5.0\text{V}$ ,  $T_A = 25^\circ\text{C}$ .

Symbol	Parameter	Conditions	Min	Typ	Max	Units
<b>TRANSMIT FILTER (Transmit filter input op amp set to the non-inverting unity gain mode, with <math>V_{F_xI} = 1.09</math> Vrms unless otherwise noted.)</b>						
$RL_x$	Minimum Load Resistance, $V_{F_xO}$	$-2.5\text{V} < V_{OUT} < 2.5\text{V}$ $-3.2\text{V} < V_{OUT} < 3.2\text{V}$	3 10			k $\Omega$ k $\Omega$
$CL_x$	Load Capacitance, $V_{F_xO}$				100	pF
$RO_x$	Output Resistance, $V_{F_xO}$			1	3	$\Omega$
PSRR1	$V_{CC}$ Power Supply Rejection, $V_{F_xO}$	$f = 1$ kHz, $V_{F_xI} = 0$ Vrms	<b>30</b>			dB
PSRR2	$V_{BB}$ Power Supply Rejection, $V_{F_xO}$	Same as Above	<b>35</b>			dB
$GA_x$	Absolute Gain	$f = 1$ kHz (TP3040A) $f = 1$ kHz (TP3040)	<b>2.9</b> <b>2.875</b>	3.0 3.0	<b>3.1</b> <b>3.125</b>	dB dB
$GR_x$	Gain Relative to $GA_x$	Below 50 Hz 50 Hz 60 Hz 200 Hz (TP3040A) 200 Hz (TP3040) 300 Hz to 3 kHz (TP3040A) 300 Hz to 3 kHz (TP3040) 3.3 kHz 3.4 kHz 4.0 kHz 4.6 kHz and Above			-35 -35 -30 0 <b>0.05</b> <b>0.15</b> <b>0.03</b> -0.1 -14 -32	dB dB dB dB dB dB dB dB dB dB
$DA_x$	Absolute Delay at 1 kHz				250	$\mu\text{s}$
$DD_x$	Differential Envelope Delay from 1 kHz to 2.6 kHz				60	$\mu\text{s}$
$DP_{x1}$	Single Frequency Distortion Products				-48	dB
$DP_{x2}$	Distortion at Maximum Signal Level	0.16 Vrms, 1 kHz Signal Applied to $V_{F_xI}$ , Gain = 20 dB, $R_L = 10\text{k}$			-45	dB
$NC_{x1}$	Total C Message Noise at $V_{F_xO}$	TP3040, TP3040A		2	<b>5</b>	dBm0
$NC_{x2}$	Total C Message Noise at $V_{F_xO}$	Gain Setting Op Amp at 20 dB, Non-Inverting (Note 3) $T_A = 0^\circ\text{C}$ to $70^\circ\text{C}$ TP3040, TP3040A		3	<b>6</b>	dBm0
$GA_{xT}$	Temperature Coefficient of 1 kHz Gain			0.0004		dB/ $^\circ\text{C}$
$GA_{xS}$	Supply Voltage Coefficient of 1 kHz Gain	$V_{CC} = 5.0\text{V} \pm 5\%$ $V_{BB} = -5.0\text{V} \pm 5\%$		0.01		dB/V
$CT_{RX}$	Crosstalk, Receive to Transmit $20 \log \frac{V_{F_xO}}{V_{F_xO}}$	Receive Filter Output = 2.2 Vrms $V_{F_xI} = 0$ Vrms, $f = 0.2$ kHz to 3.4 kHz Measure $V_{F_xO}$			-70	dB
$GR_{xL}$	Gaintracking Relative to $GA_x$	Output Level = +3 dBm0 +2 dBm0 to -40 dBm0 -40 dBm0 to -55 dBm0	-0.1 -0.05 -0.1		0.1 0.05 0.1	dB dB dB

## AC Electrical Characteristics (Continued)

Unless otherwise specified,  $T_A = 25^\circ\text{C}$ . All parameters are specified for a signal level of 0 dBm0 at 1 kHz. The 0 dBm0 level is assumed to be 1.54 Vrms measured at the output of the transmit or receive filter. Limits printed in **BOLD** characters are guaranteed for  $V_{CC} = +5.0\text{V} \pm 5\%$ ,  $V_{BB} = -5.0\text{V} \pm 5\%$ ;  $T_A = 0^\circ\text{C}$  to  $70^\circ\text{C}$  by correlation with 100% electrical testing at  $T_A = 25^\circ\text{C}$ . All other limits are assured by correlation with other production tests and/or product design and characterization. Typicals specified at  $V_{CC} = +5.0\text{V}$ ,  $V_{BB} = -5.0\text{V}$ ,  $T_A = 25^\circ\text{C}$ .

Symbol	Parameter	Conditions	Min	Typ	Max	Units
<b>RECEIVE FILTER (Unless otherwise noted, the receive filter is preceded by a sin x/x filter with an input signal level of 1.54 Vrms.)</b>						
$IB_R$	Input Leakage Current, $VF_{RI}$	$-3.2\text{V} \leq V_{IN} \leq 3.2\text{V}$	<b>-100</b>		<b>100</b>	nA
$RI_R$	Input Resistance, $VF_{RI}$		10			$M\Omega$
$RO_R$	Output Resistance, $VF_{RO}$			1	3	$\Omega$
$CL_R$	Load Capacitance, $VF_{RO}$				100	pF
$RL_R$	Load Resistance, $VF_{RO}$		10			$k\Omega$
PSRR3	Power Supply Rejection of $V_{CC}$ or $V_{BB}$ , $VF_{RO}$	$VF_{RI}$ Connected to GNDA $f = 1$ kHz	<b>35</b>			dB
$VOS_{RO}$	Output DC Offset, $VF_{RO}$	$VF_{RI}$ Connected to GNDA	<b>-200</b>		<b>200</b>	mV
$GA_R$	Absolute Gain	$f = 1$ kHz (TP3040A) $f = 1$ kHz (TP3040)	<b>-0.1</b> <b>-0.125</b>	0 0	<b>0.1</b> <b>0.125</b>	dB dB
$GR_R$	Gain Relative to Gain at 1 kHz	Below 300 Hz 300 Hz to 3.0 kHz (TP3040A) 300 Hz to 3.0 kHz (TP3040) 3.3 kHz 3.4 kHz 4.0 kHz 4.6 kHz and Above	<b>-0.125</b> <b>-0.15</b> <b>-0.35</b> <b>-0.7</b>		<b>0.125</b> <b>0.125</b> <b>0.15</b> <b>0.03</b> <b>-0.1</b> <b>-14</b> <b>-32</b>	dB dB dB dB dB dB dB
$DA_R$	Absolute Delay at 1 kHz				140	$\mu\text{s}$
$DD_R$	Differential Envelope Delay 1 kHz to 2.6 kHz				100	$\mu\text{s}$
$DP_{R1}$	Single Frequency Distortion Products	$f = 1$ kHz			<b>-48</b>	dB
$DP_{R2}$	Distortion at Maximum Signal Level	2.2 Vrms Input to Sin x/x Filter, $f = 1$ kHz, $R_L = 10k$			-45	dB
$NC_R$	Total C-Message Noise at $VF_{RO}$	TP3040, TP3040A		3	<b>5</b>	dBmnc0
$GA_{RT}$	Temperature Coefficient of 1 kHz Gain			0.0004		dB/ $^\circ\text{C}$
$GA_{RS}$	Supply Voltage Coefficient of 1 kHz Gain			0.01		dB/V
$CT_{XR}$	Crosstalk, Transmit to Receive $20 \log \frac{VF_{RO}}{VF_{XO}}$	Transmit Filter Output = 2.2 Vrms $VF_{RI} = 0$ Vrms, $f = 0.3$ kHz to 3.4 kHz Measure $VF_{RO}$			<b>-70</b>	dB
$GR_{RL}$	Gaintracking Relative to $GA_R$	Output Level = +3 dBm0 +2 dBm0 to -40 dBm0 -40 dBm0 to -55 dBm0 (Note 5)	<b>-0.1</b> <b>-0.05</b> <b>-0.1</b>		<b>0.1</b> <b>0.05</b> <b>0.1</b>	dB dB dB

## AC Electrical Characteristics (Continued)

Unless otherwise specified,  $T_A = 25^\circ\text{C}$ . All parameters are specified for a signal level of 0 dBm0 at 1 kHz. The 0 dBm0 level is assumed to be 1.54 Vrms measured at the output of the transmit or receive filter. Limits printed in **BOLD** characters are guaranteed for  $V_{CC} = +5.0\text{V} \pm 5\%$ ,  $V_{BB} = -5.0\text{V} \pm 5\%$ ;  $T_A = 0^\circ\text{C}$  to  $70^\circ\text{C}$  by correlation with 100% electrical testing at  $T_A = 25^\circ\text{C}$ . All other limits are assured by correlation with other production tests and/or product design and characterization. Typicals specified at  $V_{CC} = +5.0\text{V}$ ,  $V_{BB} = -5.0\text{V}$ ,  $T_A = 25^\circ\text{C}$ .

Symbol	Parameter	Conditions	Min	Typ	Max	Units
<b>RECEIVE OUTPUT POWER AMPLIFIER</b>						
IBP	Input Leakage Current, PWRI	$-3.2\text{V} \leq V_{IN} \leq 3.2\text{V}$	<b>0.1</b>		<b>3</b>	$\mu\text{A}$
RIP	Input Resistance, PWRI		10			$\text{M}\Omega$
ROP1	Output Resistance, PWRO+, PWRO-	Amplifiers Active		1		$\Omega$
CLP	Load Capacitance, PWRO+, PWRO-				500	pF
$\text{GA}_{p+}$ $\text{GA}_{p-}$	Gain, PWRI to PWRO+ Gain, PWRI to PWRO-	$R_L = 600\Omega$ Connected Between PWRO+ and PWRO-, Input Level = 0 dBm0 (Note 4)		1 -1		V/V V/V
$\text{GR}_{pL}$	Gaintracking Relative to 0 dBm0 Output Level, Including Receive Filter	$V = 2.05\text{ Vrms}$ , $R_L = 600\Omega$ (Notes 4, 5) $V = 1.75\text{ Vrms}$ , $R_L = 300\Omega$	<b>-0.1</b> <b>-0.1</b>		<b>0.1</b> 0.1	dB dB
S/D <sub>p</sub>	Signal/Distortion	$V = 2.05\text{ Vrms}$ , $R_L = 600\Omega$ (Notes 4, 5) $V = 1.75\text{ Vrms}$ , $R_L = 300\Omega$			<b>-45</b> <b>-45</b>	dB dB
VOSP	Output DC Offset, PWRO+, PWRO-	PWRI Connected to GNDA	<b>-50</b>		<b>50</b>	mV
PSRR5	Power Supply Rejection of $V_{CC}$ or $V_{BB}$	PWRI Connected to GNDA	45			dB

**Note 1:** Maximum power consumption will depend on the load impedance connected to the power amplifier. This specification listed assumes 0 dBm is delivered to  $600\Omega$  connected from PWRO+ to PWRO-.

**Note 2:** Voltage input to receive filter at 0V,  $V_{FRO}$  connected to PWRI,  $600\Omega$  from PWRO+ to PWRO-. Output measured from PWRO+ to PWRO-.

**Note 3:** The 0 dBm0 level for the filter is assumed to be 1.54 Vrms measured at the output of the XMT or RCV filter.

**Note 4:** The 0 dBm0 level for the power amplifiers is load dependent. For  $R_L = 600\Omega$  to GNDA, the 0 dBm0 level is 1.43 Vrms measured at the amplifier output. For  $R_L = 300\Omega$  the 0 dBm0 level is 1.22 Vrms.

**Note 5:**  $V_{FRO}$  connected to PWRI, input signal applied to  $V_{FRI}$ .

**Note 6:** Previous revisions of the datasheet did not clearly indicate this specification requires power amps in powerdown (PWRI = -5.25V).

## Typical Application

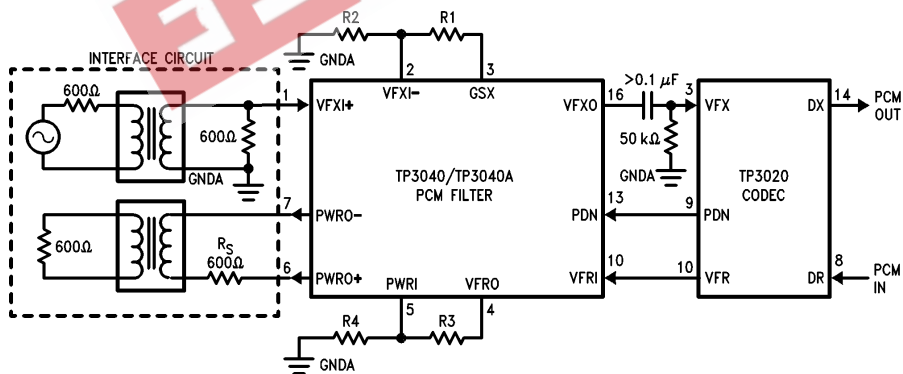

TL/H/6660-2

**Note 1:** Transmit voltage gain =  $\frac{R1 + R2}{R2} \times \sqrt{2}$  (The filter itself introduces a 3 dB gain), ( $R1 + R2 \geq 10k$ )

**Note 2:** Receive gain =  $\frac{R4}{R3 + R4}$   
( $R3 + R4 \geq 10k$ )

**Note:** In the configuration shown, the receive filter power amplifiers will drive a  $600\Omega$  T to R termination to a maximum signal level of 8.5 dBm. An alternative arrangement, using a transformer winding ratio equivalent to 1.414:1 and  $300\Omega$  resistor,  $R_S$ , will provide a maximum signal level of 10.1 dBm across a  $600\Omega$  termination impedance.

FIGURE 2

## Connection Diagrams

Dual-In-Line Package

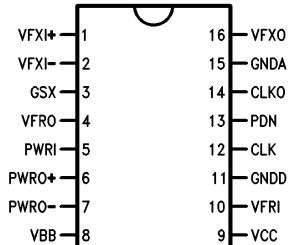

Top View

Order Number TP3040J or TP3040AJ  
See NS Package J16A  
or  
TP3040N or TP3040AN  
See NS Package N16A

TL/H/6660-3

Plastic Lead Chip Carrier

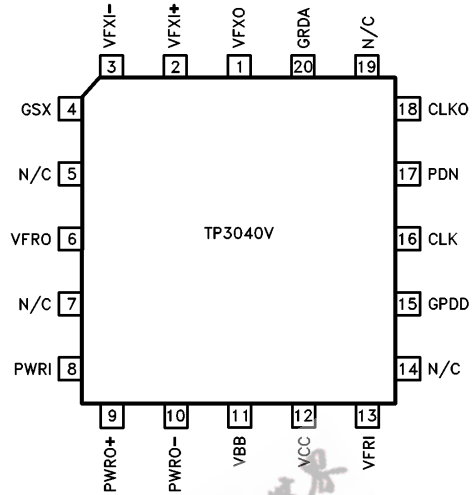

Order Number TP3040V or TP3040AV  
See NS Package V20A

TL/H/6660-4

## Description of Pin Functions

Symbol	Function	Symbol	Function
VFXI+	The non-inverting input to the transmit filter stage.	GNDD	Digital ground input pin. All digital signals are referenced to this pin.
VFXI-	The inverting input to the transmit filter stage.	CLK	Master input clock. Input frequency can be selected as 2.048 MHz, 1.544 MHz or 1.536 MHz.
GSX	The output used for gain adjustments of the transmit filter.	PDN	The input pin used to power down the TP3040/TP3040A during idle periods. Logic 1 (VCC) input voltage causes a power down condition. An internal pull-up is provided.
VFRO	The low power receive filter output. This pin can directly drive the receive port of an electronic hybrid.	CLK0	This input pin selects internal counters in accordance with the CLK input clock frequency:
PWRI	The input to the receive filter differential power amplifier.		
PWRO+	The non-inverting output of the receive filter power amplifier. This output can directly interface conventional transformer hybrids.		
PWRO-	The inverting output of the receive filter power amplifier. This output can be used with PWRO+ to differentially drive a transformer hybrid.		
VBB	The negative power supply pin. Recommended input is -5V.		
VCC	The positive power supply pin. The recommended input is 5V.		
VFRI	The input pin for the receive filter stage.		

## Functional Description

The TP3040/TP3040A monolithic filter contains four main sections; Transmit Filter, Receive Filter, Receive Filter Power Amplifier, and Frequency Divider/Select Logic (*Figure 1*). A brief description of the circuit operation for each section is provided below.

### TRANSMIT FILTER

The input stage of the transmit filter is a CMOS operational amplifier which provides an input resistance of greater than 10 M $\Omega$ , a voltage gain of greater than 5,000, low power consumption (less than 3 mW), high power supply rejection, and is capable of driving a 10 k $\Omega$  load in parallel with up to 25 pF. The inputs and output of the amplifier are accessible for added flexibility. Non-inverting mode, inverting mode, or differential amplifier mode operation can be implemented with external resistors. It can also be connected to provide a gain of up to 20 dB without degrading the overall filter performance.

The input stage is followed by a prefilter which is a two-pole RC active low pass filter designed to attenuate high frequency noise before the input signal enters the switched-capacitor high pass and low pass filters.

A high pass filter is provided to reject 200 Hz or lower noise which may exist in the signal path. The low pass portion of the switched-capacitor filter provides stopband attenuation which exceeds the D3 and D4 specifications as well as the CCITT G712 recommendations (*Figure 3*).

The output stage of the transmit filter, the postfilter, is also a two-pole RC active low pass filter which attenuates clock frequency noise by at least 40 dB. The output of the transmit filter is capable of driving a  $\pm 3.2$ V peak to peak signal into a 10 k $\Omega$  load in parallel with up to 25 pF.

### RECEIVE FILTER

The input stage of the receive filter is a prefilter which is similar to the transmit prefilter. The prefilter attenuates high frequency noise that may be present on the receive input signal. A switched capacitor low pass filter follows the prefilter to provide the necessary passband flatness, stopband rejection and sin x/x gain correction. A postfilter which is similar to the transmit postfilter follows the low pass stage. It attenuates clock frequency noise and provides a low output impedance capable of directly driving an electronic subscriber-line-interface circuit (*Figure 3*).

### RECEIVE FILTER POWER AMPLIFIERS

Two power amplifiers are also provided to interface to transformer coupled line circuits. These two amplifiers are driven by the output of the receive postfilter through gain setting resistors, R3, R4 (*Figure 2*). The power amplifiers can be deactivated, when not required, by connecting the power amplifier input (pin 5) to the negative power supply V<sub>BB</sub>. This reduces the total filter power consumption by approximately 10 mW–20 mW depending on output signal amplitude.

### POWER DOWN CONTROL

A power down mode is also provided. A logic 1 power down command applied on the PDN pin (pin 13) will reduce the total filter power consumption to less than 1 mW. Connect PDN to GNDD for normal operation.

### FREQUENCY DIVIDER AND SELECT LOGIC CIRCUIT

This circuit divides the external clock frequency down to the switching frequency of the low pass and high pass switched capacitor filters. The divider also contains a TTL-CMOS interface circuit which converts the external TTL clock level to the CMOS logic level required for the divider logic. This interface circuit can also be directly driven by CMOS logic. A frequency select circuit is provided to allow the filter to operate with 2.048 MHz, 1.544 MHz or 1.536 MHz clock frequencies. By connecting the frequency select pin CLK0 (pin 14) to V<sub>CC</sub>, a 2.048 MHz clock input frequency is selected. Digital ground selects 1.544 MHz and V<sub>BB</sub> selects 1.536 MHz.

## Applications Information

### GAIN ADJUST

*Figure 2* shows the signal path interconnections between the TP3040/TP3040A and the TP3020 signal-channel CODEC. The transmit RC coupling components have been chosen both for minimum passband droop and to present the correct impedance to the CODEC during sampling.

Optimum noise and distortion performance will be obtained from the TP3040/TP3040A filter when operated with system peak overload voltages of  $\pm 2.5$ V to  $\pm 3.2$ V at V<sub>F<sub>X</sub>O</sub> and V<sub>F<sub>R</sub>O</sub>. When interfacing to a PCM CODEC with a peak overload voltage outside this range, further gain or attenuation may be required.

### BOARD LAYOUT

Care must be taken in PCB layout to minimize power supply and ground noise. Analog ground (GNDA) of each filter should be connected to digital ground (GNDD) at a single point, which should be bypassed to both power supplies. Further power supply decoupling adjacent to each filter and CODEC is recommended. Ground loops should be avoided, both between GNDA and GNDD and between the GNDA traces of adjacent filters and CODECs.

## Typical Performance Characteristics

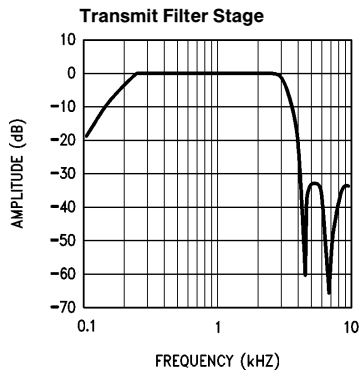

TL/H/6660-5

FIGURE 3

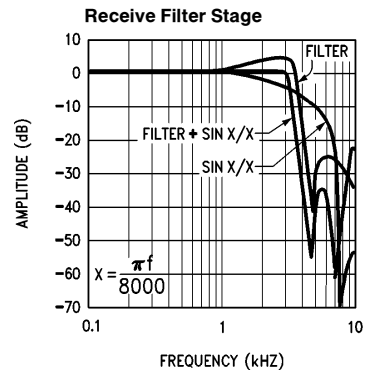

TL/H/6660-6

EEPW 电子产品世界 .com.cn



## Physical Dimensions

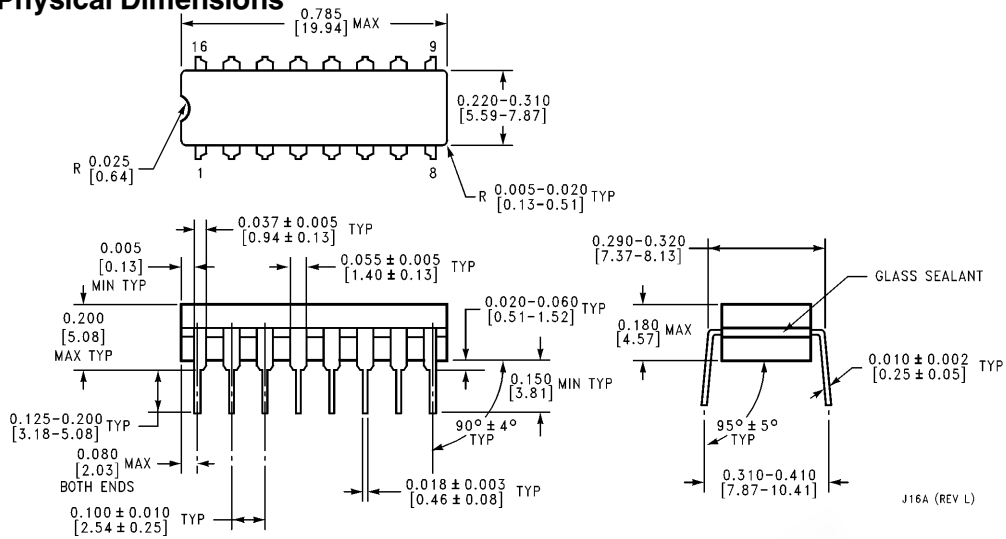

**Ceramic Dual-In-Line Package (J)**  
**Order Number TP3040J or TP3040AJ**  
**NS Package Number J16A**

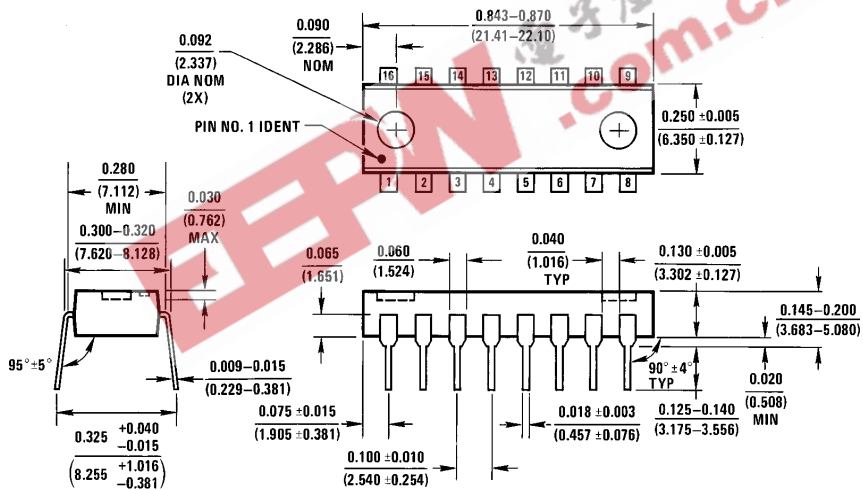

**Molded Dual-In-Line Package (M)**  
**Order Number TP3040N or TP3040AN**  
**NS Package Number N16A**

Physical Dimensions (Continued)

Lit. # 113919

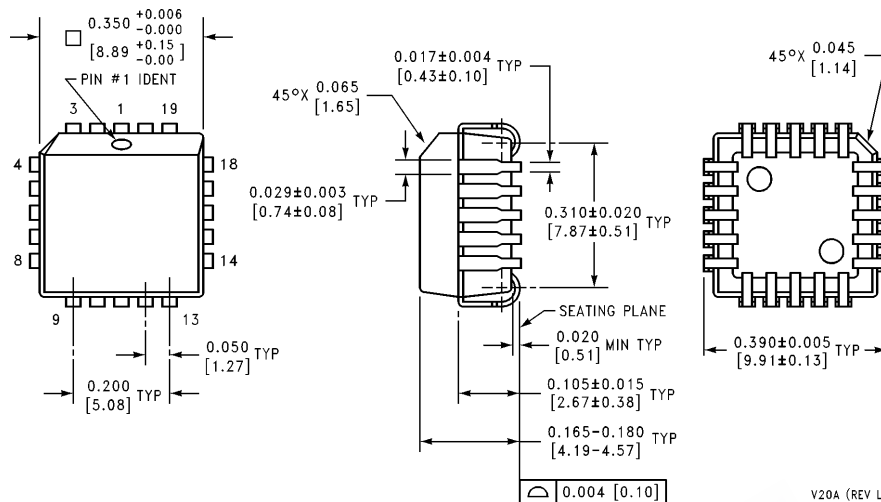

20-Lead Plastic Chip Carrier  
 Order Number TP3040V or TP3040AV  
 NS Package Number V20A

V20A (REV L)



LIFE SUPPORT POLICY

NATIONAL'S PRODUCTS ARE NOT AUTHORIZED FOR USE AS CRITICAL COMPONENTS IN LIFE SUPPORT DEVICES OR SYSTEMS WITHOUT THE EXPRESS WRITTEN APPROVAL OF THE PRESIDENT OF NATIONAL SEMICONDUCTOR CORPORATION. As used herein:

1. Life support devices or systems are devices or systems which, (a) are intended for surgical implant into the body, or (b) support or sustain life, and whose failure to perform, when properly used in accordance with instructions for use provided in the labeling, can be reasonably expected to result in a significant injury to the user.
2. A critical component is any component of a life support device or system whose failure to perform can be reasonably expected to cause the failure of the life support device or system, or to affect its safety or effectiveness.



**National Semiconductor Corporation**  
 1111 West Bardin Road  
 Arlington, TX 76017  
 Tel: 1(800) 272-9959  
 Fax: 1(800) 737-7018

**National Semiconductor Europe**  
 Fax: (+49) 0-180-530 85 86  
 Email: cnjwge@levm2.nsc.com  
 Deutsch Tel: (+49) 0-180-530 85 85  
 English Tel: (+49) 0-180-532 78 32  
 Français Tel: (+49) 0-180-532 93 58  
 Italiano Tel: (+49) 0-180-534 16 80

**National Semiconductor Hong Kong Ltd.**  
 13th Floor, Straight Block,  
 Ocean Centre, 5 Canton Rd.  
 Tsimshatsui, Kowloon  
 Hong Kong  
 Tel: (852) 2737-1600  
 Fax: (852) 2736-9960

**National Semiconductor Japan Ltd.**  
 Tel: 81-043-299-2309  
 Fax: 81-043-299-2408