



**TS951
TS952
TS954**

INPUT/OUTPUT RAIL TO RAIL LOW POWER OPERATIONAL AMPLIFIERS

- RAIL TO RAIL **INPUT** COMMON-MODE VOLTAGE RANGE
- RAIL TO RAIL **OUTPUT** VOLTAGE SWING
- OPERATING FROM **2.7V to 12V**
- HIGH SPEED (**3MHz, 1V/μs**)
- LOW CONSUMPTION (**0.9mA @ 3V**)
- SUPPLY VOLTAGE REJECTION RATIO : **80dB**
- ESD PROTECTION (**2kV**)
- LATCH-UP IMMUNITY
- AVAILABLE IN **SOT23-5 MICROPACKAGE**

DESCRIPTION

The TS95x family are RAIL TO RAIL BiCMOS operational amplifiers optimized and fully specified for 3V and 5V operation.

The TS951 is housed in the space-saving 5 pins SOT23 package that makes it well suited for battery-powered systems. This micropackage simplifies the PC board design because of its ability to be placed in tight spaces (outside dimensions are : 2.8mm x 2.9mm)

APPLICATIONS

- Set-top boxes
- Laptop/Notebook computers
- Transformer/Line drivers
- Personal entertainments (CD players)
- Portable communication (cell phones, pagers)
- Instrumentation & sensing
- Digital to Analog converter buffers
- Portable headphone speaker drivers

ORDER CODES

| Part Number | Temperature Range | Package | | | | SOT23 Marking |
|-------------|-------------------|---------|---|---|---|---------------|
| | | N | D | P | L | |
| TS951I | -40, +125°C | | • | | • | K101 |
| TS952I | -40, +125°C | • | • | • | | |
| TS954I | -40, +125°C | • | • | • | | |

N = Dual in Line Package (DIP)

D = Small Outline Package (SO) - also available in Tape & Reel

P = Thin Shrink Small Outline Package (TSSOP) - only available in Tape & Reel (PT)

L = Tiny Package (SOT23-5) - only available in Tape & Reel (LT)

PIN CONNECTIONS (top view)

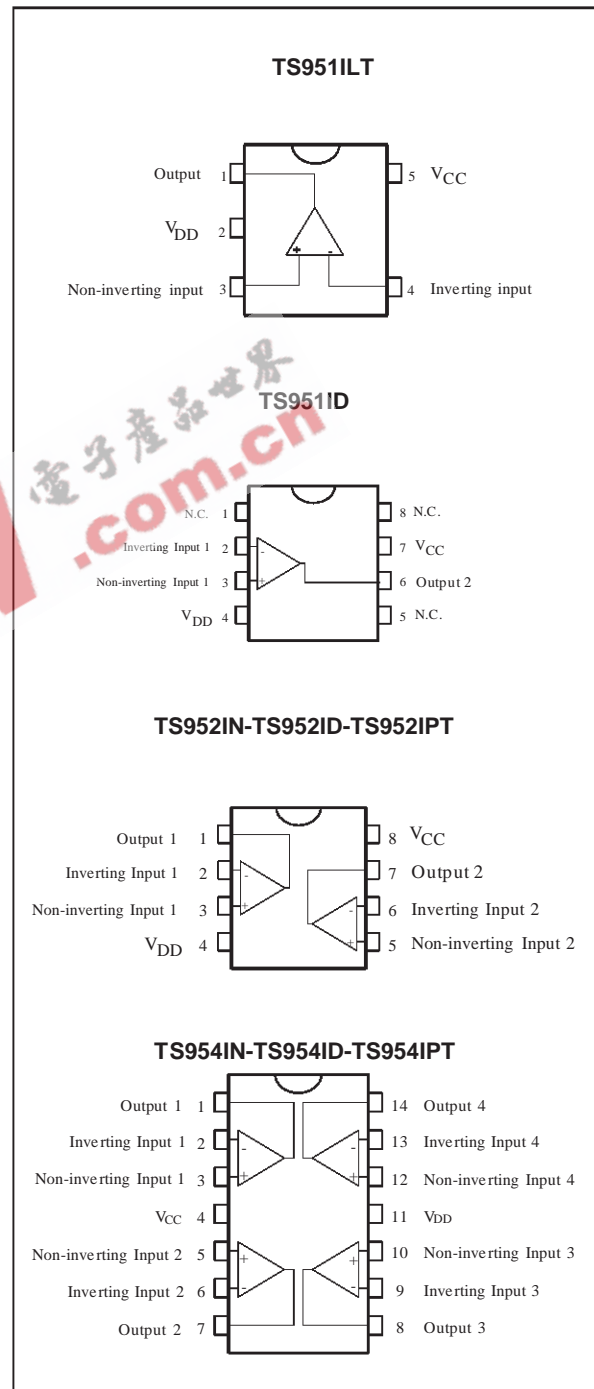

ABSOLUTE MAXIMUM RATINGS

| Symbol | Parameter | Value | Unit |
|-------------------|---|----------------------------|------|
| V _{CC} | Supply Voltage - note 1 | 12 | V |
| V _{id} | Differential Input Voltage - note 2 | ±1 | V |
| V _{in} | Input Voltage Range - note 3 | -0.3 to 12.3 | V |
| T _{oper} | Operating Free Air Temperature Range | -40 to +125 | °C |
| T _{stg} | Storage Temperature Range | -65 to +150 | °C |
| T _j | Maximum Junction Temperature | 150 | °C |
| R _{thjc} | Thermal Resistance Junction to Case - note 4 SOT23-5 SO8 SO14 TSSOP8 TSSOP14 | 81 28 22 26 21 | °C/W |
| R _{thja} | Thermal Resistance Junction to Ambient - SOT23-5 | 256 | °C/W |
| ESD | Human Body Model | 2 | kV |
| | Lead Temperature (soldering, 10sec) | 260 | °C |

- Notes:**
1. All voltages values, except differential voltage are with respect to network ground terminal.
 2. Differential voltages are non-inverting input terminal with respect to the inverting input terminal.
 3. The magnitude of input and output voltages must never exceed V_{CC} +0.3V.
 4. Short-circuits can cause excessive heating and destructive dissipation.

OPERATING CONDITIONS

| Symbol | Parameter | Value | Unit |
|------------------|---------------------------------|--|------|
| V _{CC} | Supply Voltage Range | 2.7 to 12 | V |
| V _{icm} | Common Mode Input Voltage Range | V _{DD} - 0.2 to V _{CC} + 0.2 | V |

ELECTRICAL CHARACTERISTICS

$V_{CC} = +3V$, $V_{DD} = 0V$, $T_{amb} = 25^{\circ}C$ (unless otherwise specified)

| Symbol | Parameter | Min. | Typ. | Max. | Unit |
|-----------|---|----------------------------------|------|------------|------------------------|
| V_{io} | Input Offset Voltage $T_{min.} \leq T_{amb} \leq T_{max.}$ | | | 6 8 | mV |
| DV_{io} | Input Offset Voltage Drift | | 2 | | $\mu V/^{\circ}C$ |
| I_{io} | Input Offset Current $T_{min.} \leq T_{amb} \leq T_{max.}$ | | 1 | 30 80 | nA |
| I_{ib} | Input Bias Current $V_{icm} = 1.5V$ $T_{min.} \leq T_{amb} \leq T_{max.}$ | | 35 | 100 200 | nA |
| V_{icm} | Common Mode Input Voltage Range | $V_{DD} - 0.2$ to $V_{CC} + 0.2$ | | | V |
| CMR | Common Mode Rejection Ratio | 50 | 80 | | dB |
| SVR | Supply Voltage Rejection Ratio $V_{CC} = 2.7V$ to $3.3V$ | 60 | 80 | | dB |
| A_{vd} | Large Signal Voltage Gain $V_o = 2V_{pk-pk}$ $R_L = 600\Omega$ | | 80 | | dB |
| V_{OH} | High Level Output Voltage $R_L = 600\Omega$ | 2.8 | 2.9 | | V |
| V_{OL} | Low Level Output Voltage $R_L = 600\Omega$ | | 80 | 250 | mV |
| I_{sc} | Output Short Circuit Current | 10 | | | mA |
| I_{CC} | Supply Current (per amplifier) No load, $V_o = V_{CC}/2$ | | 0.9 | 1.3 | mA |
| GBP | Gain Bandwidth Product $R_L = 2k\Omega$ | | 3 | | MHz |
| SR | Slew Rate | | 1 | | V/ μs |
| ϕ_m | Phase Margin at Unity Gain $R_L = 600\Omega$, $C_L = 100pF$ | | 60 | | Degrees |
| G_m | Gain Margin $R_L = 600\Omega$, $C_L = 100pF$ | | 10 | | dB |
| e_n | Equivalent Input Noise Voltage $f = 1kHz$ | | 25 | | $\frac{nV}{\sqrt{Hz}}$ |
| THD | Total Harmonic Distortion $V_o = 4V_{pk-pk}$, $f = 10kHz$, $A_V = 2$, $R_L = 10k\Omega$ | | 0.01 | | % |

ELECTRICAL CHARACTERISTICS

V_{CC} = +5V, V_{DD} = 0V, T_{amb} = 25°C (unless otherwise specified)

| Symbol | Parameter | Min. | Typ. | Max. | Unit |
|------------------|--|--|------|------------|------------------------|
| V _{io} | Input Offset Voltage T _{min.} ≤ T _{amb} ≤ T _{max.} | | | 6 8 | mV |
| DV _{io} | Input Offset Voltage Drift | | 2 | | μV/°C |
| I _{io} | Input Offset Current T _{min.} ≤ T _{amb} ≤ T _{max.} | | 1 | 30 80 | nA |
| I _{ib} | Input Bias Current V _{icm} = 1.5V T _{min.} ≤ T _{amb} ≤ T _{max.} | | 35 | 100 200 | nA |
| V _{icm} | Common Mode Input Voltage Range | V _{DD} - 0.2 to V _{CC} + 0.2 | | | V |
| CMR | Common Mode Rejection Ratio | 50 | 80 | | dB |
| SVR | Supply Voltage Rejection Ratio V _{CC} = 2.7V to 3.3V | 60 | 80 | | dB |
| A _{vd} | Large Signal Voltage Gain V _o = 2V _{pk-pk} R _L = 600Ω | | 86 | | dB |
| V _{OH} | High Level Output Voltage R _L = 600Ω | 4.7 | 4.8 | | V |
| V _{OL} | Low Level Output Voltage R _L = 600Ω | | 80 | 300 | mV |
| I _{sc} | Output Short Circuit Current | 10 | | | mA |
| I _{CC} | Supply Current (per amplifier) No load, V _o = V _{CC} /2 | | 0.95 | 1.4 | mA |
| GBP | Gain Bandwidth Product R _L = 2kΩ | | 3 | | MHz |
| SR | Slew Rate | | 1 | | V/μs |
| ∅ _m | Phase Margin at Unity Gain R _L = 600Ω, C _L = 100pF | | 60 | | Degrees |
| G _m | Gain Margin R _L = 600Ω, C _L = 100pF | | 10 | | dB |
| e _n | Equivalent Input Noise Voltage f = 1kHz | | 25 | | $\frac{nV}{\sqrt{Hz}}$ |
| THD | Total Harmonic Distortion V _o = 4V _{pk-pk} , f = 10kHz, A _v = 2, R _L = 10kΩ | | 0.01 | | % |

SUPPLY CURRENT VERSUS SUPPLY VOLTAGE

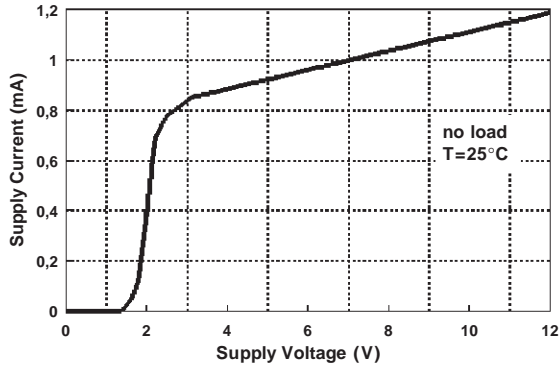

SUPPLY CURRENT VERSUS TEMPERATURE

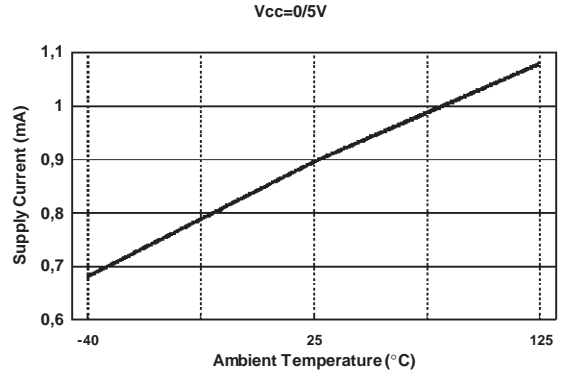

OUTPUT SHORT CIRCUIT CURRENT VERSUS OUTPUT VOLTAGE

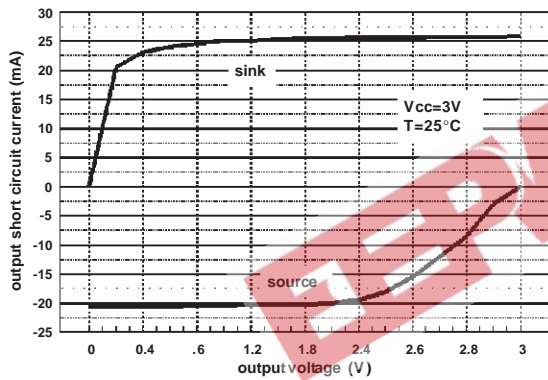

OUTPUT SHORT CIRCUIT CURRENT VERSUS TEMPERATURE

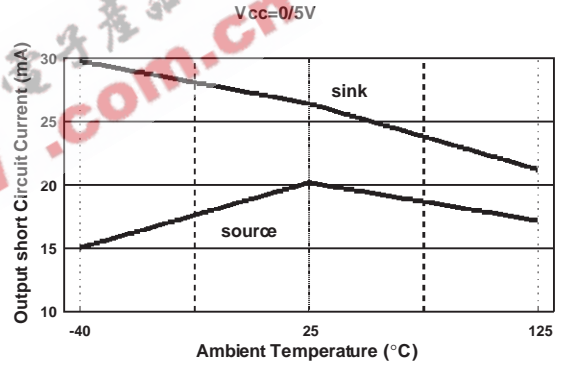

VOLTAGE GAIN AND PHASE VERSUS FREQUENCY

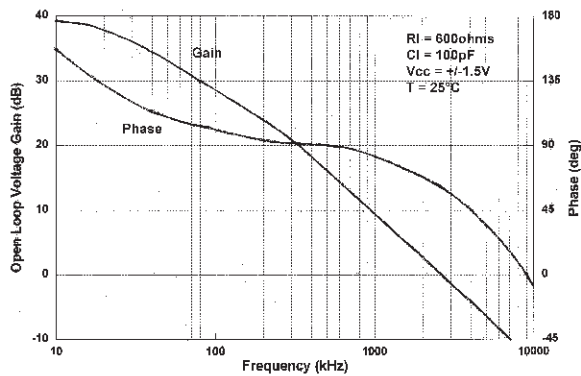

SLEW RATE VERSUS TEMPERATURE

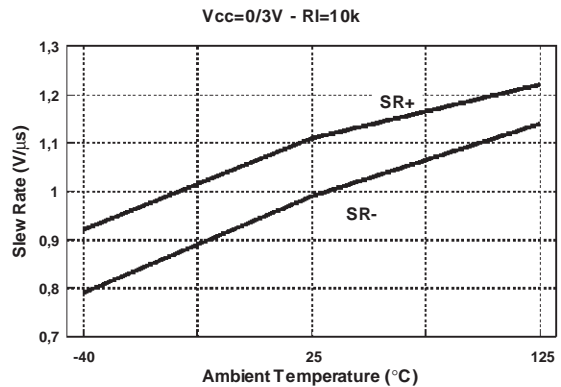

THD + NOISE VERSUS V_{out}

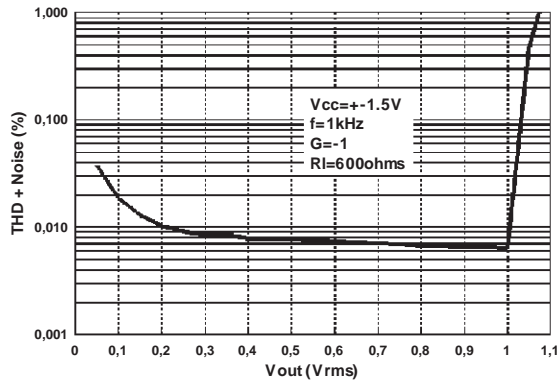

THD + NOISE VERSUS V_{out}

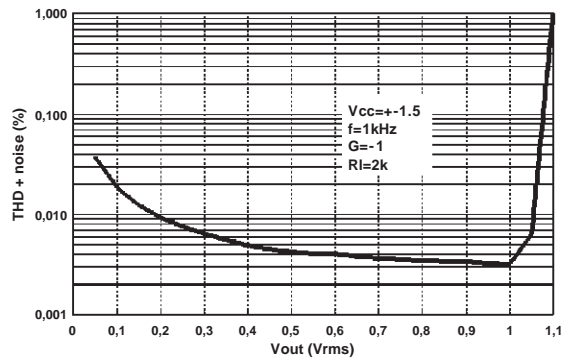

THD + NOISE VERSUS FREQUENCY

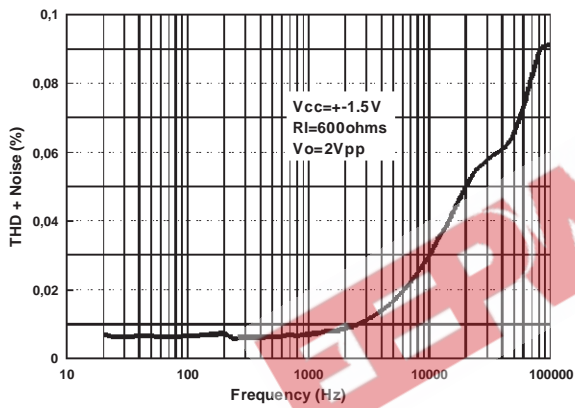

EQUIVALENT INPUT NOISE VOLTAGE VERSUS FREQUENCY

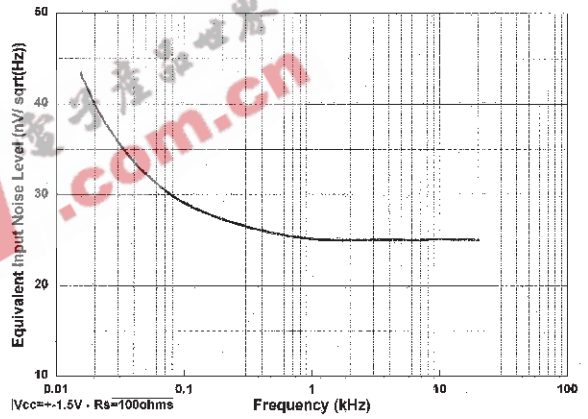

TS952IN

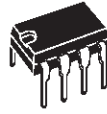

PACKAGE MECHANICAL DATA
8 PINS - PLASTIC PACKAGE

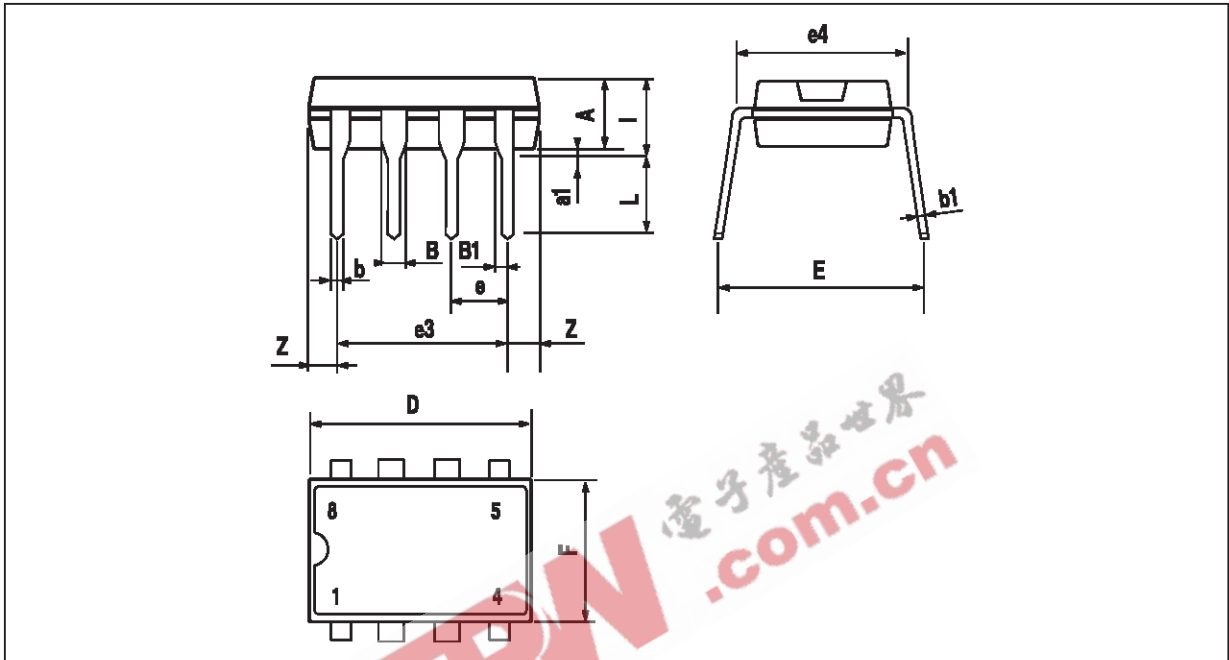

| Dimensions | Millimeters | | | Inches | | |
|------------|-------------|------|-------|--------|-------|-------|
| | Min. | Typ. | Max. | Min. | Typ. | Max. |
| A | | 3.32 | | | 0.131 | |
| a1 | 0.51 | | | 0.020 | | |
| B | 1.15 | | 1.65 | 0.045 | | 0.065 |
| b | 0.356 | | 0.55 | 0.014 | | 0.022 |
| b1 | 0.204 | | 0.304 | 0.008 | | 0.012 |
| D | | | 10.92 | | | 0.430 |
| E | 7.95 | | 9.75 | 0.313 | | 0.384 |
| e | | 2.54 | | | 0.100 | |
| e3 | | 7.62 | | | 0.300 | |
| e4 | | 7.62 | | | 0.300 | |
| F | | | 6.6 | | | 0.260 |
| i | | | 5.08 | | | 0.200 |
| L | 3.18 | | 3.81 | 0.125 | | 0.150 |
| Z | | | 1.52 | | | 0.060 |

TS951-TS952-TS954

TS951ID-TS952ID



PACKAGE MECHANICAL DATA
8 PINS - PLASTIC MICROPACKAGE (SO)

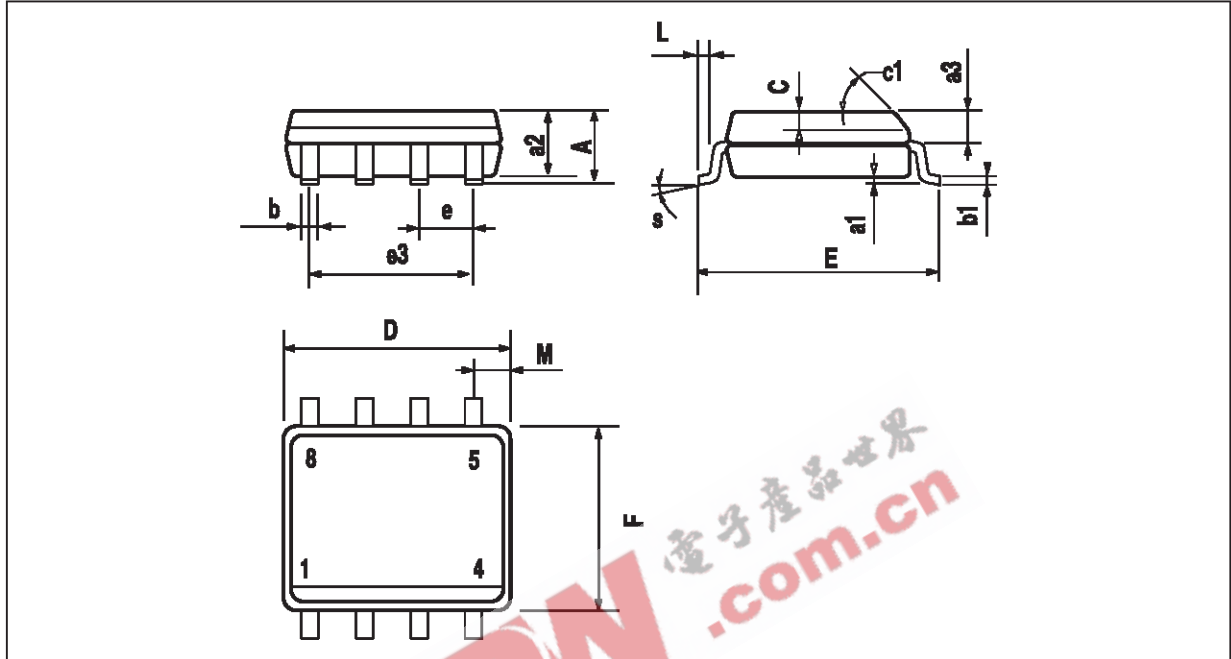

| Dim. | Millimeters | | | Inches | | |
|------|-------------|------|------|--------|-------|-------|
| | Min. | Typ. | Max. | Min. | Typ. | Max. |
| A | | | 1.75 | | | 0.069 |
| a1 | 0.1 | | 0.25 | 0.004 | | 0.010 |
| a2 | | | 1.65 | | | 0.065 |
| a3 | 0.65 | | 0.85 | 0.026 | | 0.033 |
| b | 0.35 | | 0.48 | 0.014 | | 0.019 |
| b1 | 0.19 | | 0.25 | 0.007 | | 0.010 |
| C | 0.25 | | 0.5 | 0.010 | | 0.020 |
| c1 | 45° (typ.) | | | | | |
| D | 4.8 | | 5.0 | 0.189 | | 0.197 |
| E | 5.8 | | 6.2 | 0.228 | | 0.244 |
| e | | 1.27 | | | 0.050 | |
| e3 | | 3.81 | | | 0.150 | |
| F | 3.8 | | 4.0 | 0.150 | | 0.157 |
| L | 0.4 | | 1.27 | 0.016 | | 0.050 |
| M | | | 0.6 | | | 0.024 |
| S | 8° (max.) | | | | | |

TS952IPT



PACKAGE MECHANICAL DATA
8 PINS - THIN SHRINK SMALL OUTLINE PACKAGE

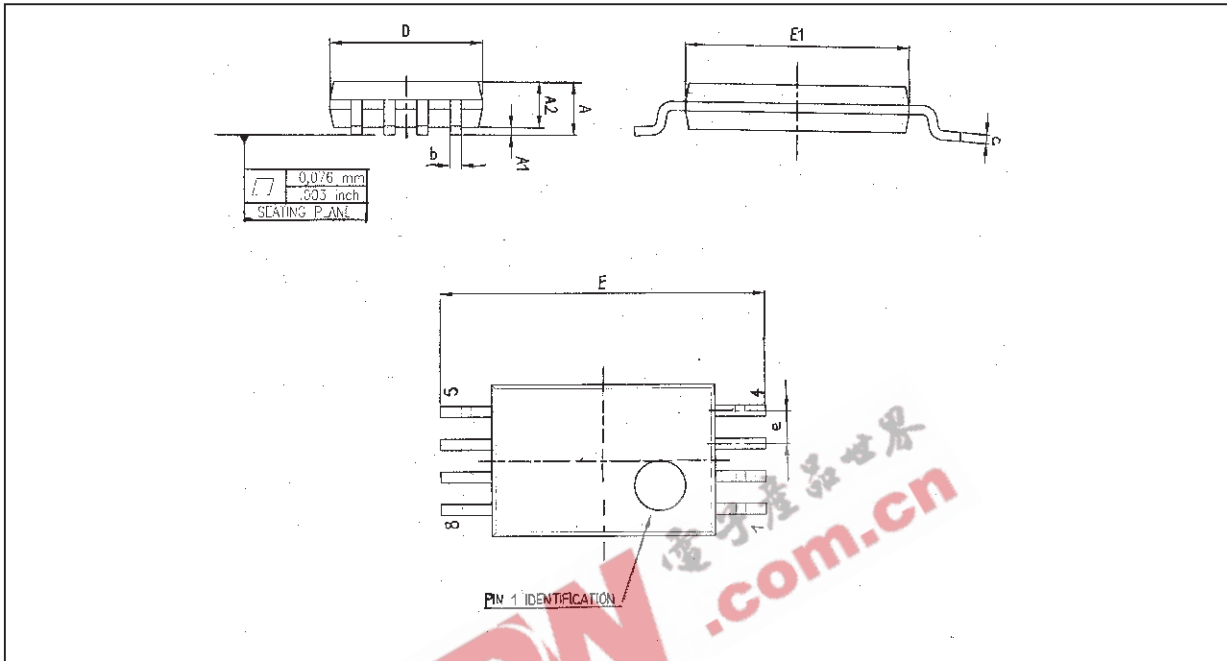

| Dim. | Millimeters | | | Inches | | |
|------|-------------|------|------|--------|--------|-------|
| | Min. | Typ. | Max. | Min. | Typ. | Max. |
| A | | | 1.20 | | | 0.05 |
| A1 | 0.05 | | 0.15 | 0.01 | | 0.006 |
| A2 | 0.80 | 1.00 | 1.05 | 0.031 | 0.039 | 0.041 |
| b | 0.19 | | 0.30 | 0.007 | | 0.15 |
| c | 0.09 | | 0.20 | 0.003 | | 0.012 |
| D | 2.90 | 3.00 | 3.10 | 0.114 | 0.118 | 0.122 |
| E | | 6.40 | | | 0.252 | |
| E1 | 4.30 | 4.40 | 4.50 | 0.169 | 0.173 | 0.177 |
| e | | 0.65 | | | 0.025 | |
| k | 0° | | 8° | 0° | | 8° |
| l | 0.50 | 0.60 | 0.75 | 0.09 | 0.0236 | 0.030 |

TS951-TS952-TS954

TS954IN

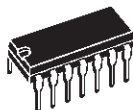

PACKAGE MECHANICAL DATA 14 PINS - PLASTIC PACKAGE

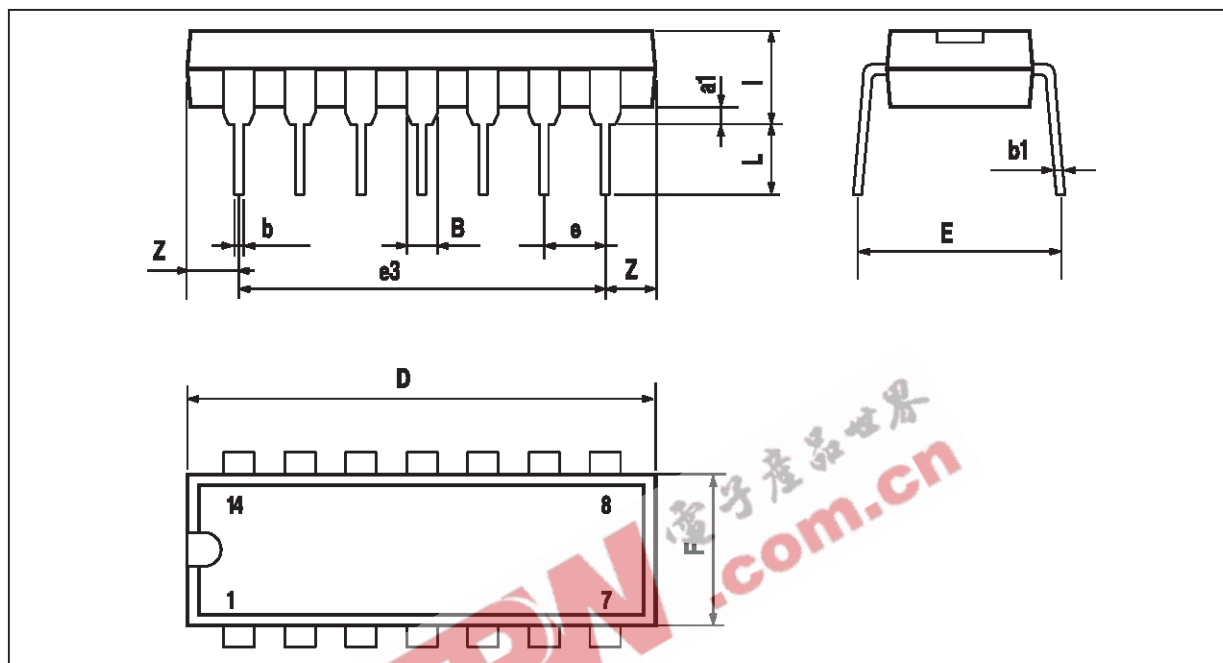

| Dim. | Millimeters | | | Inches | | |
|------|-------------|-------|------|--------|-------|-------|
| | Min. | Typ. | Max. | Min. | Typ. | Max. |
| a1 | 0.51 | | | 0.020 | | |
| B | 1.39 | | 1.65 | 0.055 | | 0.065 |
| b | | 0.5 | | | 0.020 | |
| b1 | | 0.25 | | | 0.010 | |
| D | | | 20 | | | 0.787 |
| E | | 8.5 | | | 0.335 | |
| e | | 2.54 | | | 0.100 | |
| e3 | | 15.24 | | | 0.600 | |
| F | | | 7.1 | | | 0.280 |
| i | | | 5.1 | | | 0.201 |
| L | | 3.3 | | | 0.130 | |
| Z | 1.27 | | 2.54 | 0.050 | | 0.100 |

TS954ID

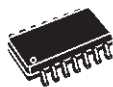

PACKAGE MECHANICAL DATA
14 PINS - PLASTIC MICROPACKAGE (SO)

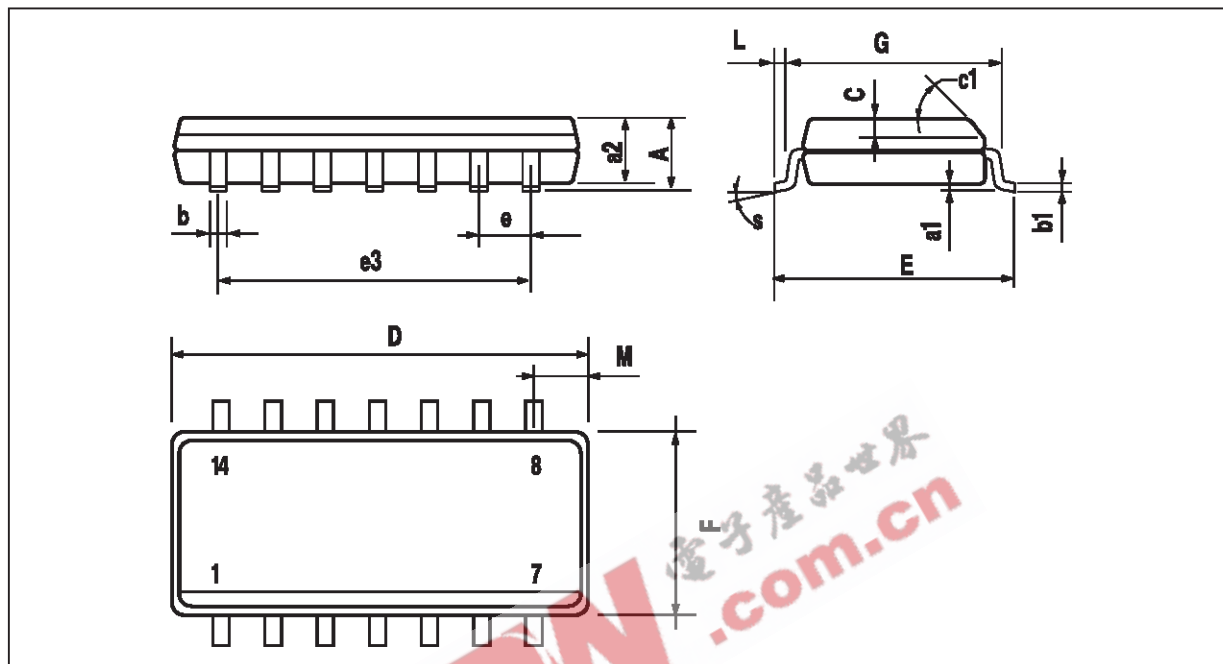

| Dim. | Millimeters | | | Inches | | |
|------|-------------|------|------|--------|-------|-------|
| | Min. | Typ. | Max. | Min. | Typ. | Max. |
| A | | | 1.75 | | | 0.069 |
| a1 | 0.1 | | 0.2 | 0.004 | | 0.008 |
| a2 | | | 1.6 | | | 0.063 |
| b | 0.35 | | 0.46 | 0.014 | | 0.018 |
| b1 | 0.19 | | 0.25 | 0.007 | | 0.010 |
| C | | 0.5 | | | 0.020 | |
| c1 | 45° (typ.) | | | | | |
| D | 8.55 | | 8.75 | 0.336 | | 0.334 |
| E | 5.8 | | 6.2 | 0.228 | | 0.244 |
| e | | 1.27 | | | 0.050 | |
| e3 | | 7.62 | | | 0.300 | |
| F | 3.8 | | 4.0 | 0.150 | | 0.157 |
| G | 4.6 | | 5.3 | 0.181 | | 0.208 |
| L | 0.5 | | 1.27 | 0.020 | | 0.050 |
| M | | | 0.68 | | | 0.027 |
| S | 8° (max.) | | | | | |

TS951-TS952-TS954

TS954IPT

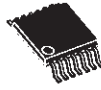

PACKAGE MECHANICAL DATA
14 PINS - THIN SHRINK SMALL OUTLINE PACKAGE

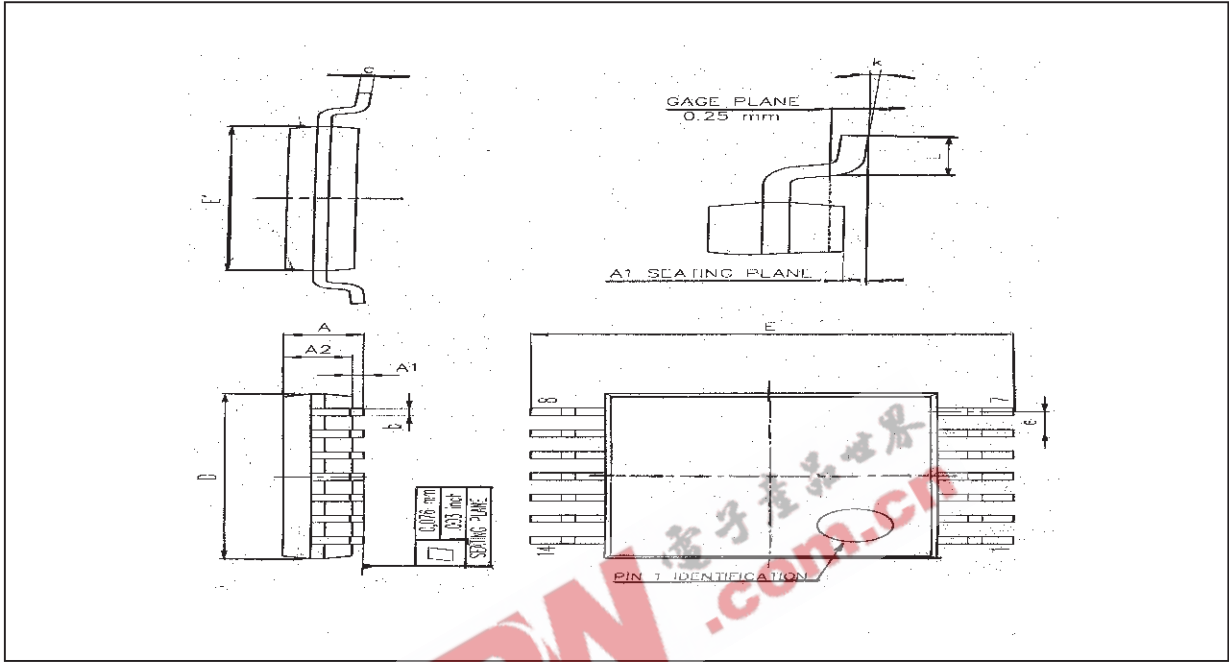

| Dim. | Millimeters | | | Inches | | |
|------|-------------|------|------|--------|--------|-------|
| | Min. | Typ. | Max. | Min. | Typ. | Max. |
| A | | | 1.20 | | | 0.05 |
| A1 | 0.05 | | 0.15 | 0.01 | | 0.006 |
| A2 | 0.80 | 1.00 | 1.05 | 0.031 | 0.039 | 0.041 |
| b | 0.19 | | 0.30 | 0.007 | | 0.15 |
| c | 0.09 | | 0.20 | 0.003 | | 0.012 |
| D | 4.90 | 5.00 | 5.10 | 0.192 | 0.196 | 0.20 |
| E | | 6.40 | | | 0.252 | |
| E1 | 4.30 | 4.40 | 4.50 | 0.169 | 0.173 | 0.177 |
| e | | 0.65 | | | 0.025 | |
| k | 0° | | 8° | 0° | | 8° |
| l | 0.50 | 0.60 | 0.75 | 0.09 | 0.0236 | 0.030 |

TS951ILT



PACKAGE MECHANICAL DATA
5 PINS -TINY PACKAGE (SOT23)

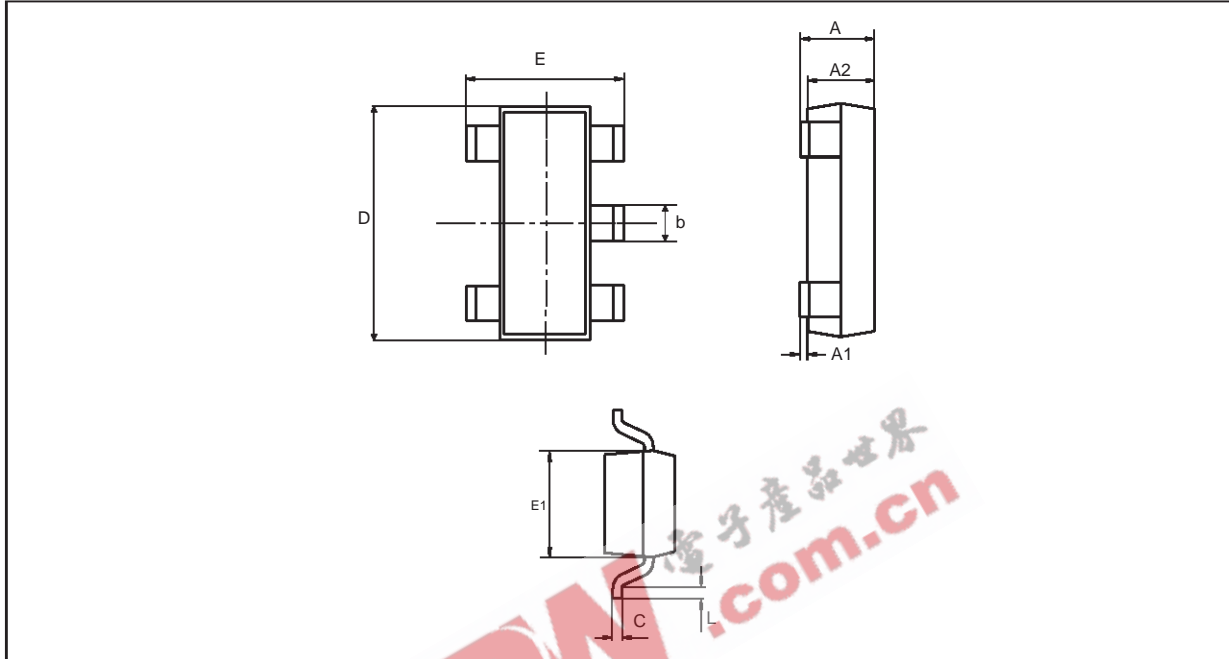

| Dim. | Millimeters | | Inches | |
|------|-------------|------|--------|-------|
| | Min. | Max. | Min. | Max. |
| A | 0.90 | 1.45 | 0.034 | 0.057 |
| A1 | 0 | 0.15 | | 0.006 |
| A2 | 0.90 | 1.30 | 0.034 | 0.051 |
| b | 0.35 | 0.50 | 0.013 | 0.020 |
| C | 0.09 | 0.20 | 0.003 | 0.008 |
| D | 2.80 | 3.00 | 0.110 | 0.118 |
| E | 2.60 | 3.00 | 0.102 | 0.118 |
| E1 | 1.50 | 1.75 | 0.059 | 0.069 |
| L | 0.10 | 0.60 | 0.003 | 0.024 |

Information furnished is believed to be accurate and reliable. However, STMicroelectronics assumes no responsibility for the consequences of use of such information nor for any infringement of patents or other rights of third parties which may result from its use. No license is granted by implication or otherwise under any patent or patent rights of STMicroelectronics. Specifications mentioned in this publication are subject to change without notice. This publication supersedes and replaces all information previously supplied. STMicroelectronics products are not authorized for use as critical components in life support devices or systems without express written approval of STMicroelectronics.

© The ST logo is a trademark of STMicroelectronics

© 1999 STMicroelectronics – Printed in Italy – All Rights Reserved

STMicroelectronics GROUP OF COMPANIES

Australia - Brazil - China - Finland - France - Germany - Hong Kong - India - Italy - Japan - Malaysia - Malta - Morocco
Singapore - Spain - Sweden - Switzerland - United Kingdom - U.S.A.

© <http://www.st.com>

