



TS1431/1431A/1431B

Adjustable Precision Shunt Regulator

TO-92



SOT-23



Pin Assignment:

1. Cathode
2. Reference
3. Anode

Sink Current Capability up to 100mA

General Description

The TS1431/1431A/1431B integrated circuits are three-terminal programmable shunt regulator diodes. These monolithic IC voltage references operate as a low temperature coefficient zener which is programmable from Vref to 36 volts with two external resistors. These devices exhibit a wide operating current range of 1.0 to 100mA with a typical dynamic impedance of 0.22Ω. The characteristics of these references make them excellent replacements for zener diodes in many applications such as digital voltmeters, power supplies, and op amp circuitry. The 2.5volt reference makes it convenient to obtain a stable reference from 5.0volt logic supplies, and since The TS1431/1431A/1431B operates as a shunt regulator, it can be used as either a positive or negative stage reference.

This series is offered in 3-pin TO-92 and SOT-23 package.

Features

- ◇ Precision Reference Voltage
 - TS1431 2.495V±2%
 - TS1431A 2.495V±1%
 - TS1431B 2.495V±0.5%
- ◇ Equivalent Full Range Temp. Coefficient: 50ppm/°C
- ◇ Programmable Output Voltage up to 36V
- ◇ Fast Turn-On Response
- ◇ Sink Current Capability of 1.0 to 100 mA
- ◇ Low Dynamic Output Impedance: 0.22Ω
- ◇ Low Output Noise

Standard Application

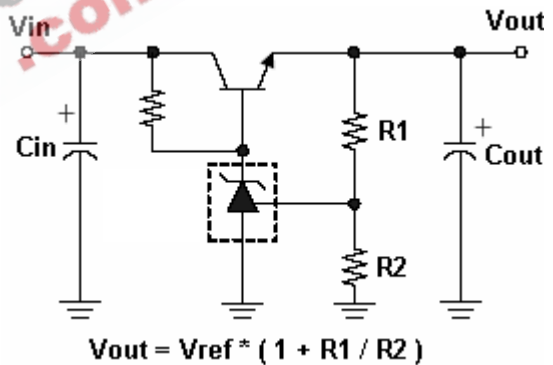

Block Diagram

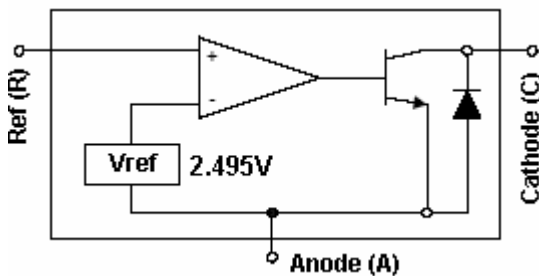

Ordering Information

Part No.	Operating Temp. (Ambient)	Package
TS1431 _x CT	-20 ~ +85 °C	TO-92
TS1431 _x CX		SOT-23

Note: Where x denotes voltage tolerance.

- Blank: ±2%
- A: ±1%
- B: ±0.5%



Absolute Maximum Rating			
Cathode Voltage (Note 1)	Vka	37	V
Continuous Cathode Current Range	I _k	-100 ~ +150	mA
Reference Input Current Range	I _{ref}	-0.05 ~ +10	mA
Power Dissipation (Note 2, 3)	Pd	TO-92	0.625
		SOT-23	0.3
Operating Junction Temperature Range	T _j	-25 ~ +125	°C
Storage Temperature Range	T _{STG}	-65 ~ +150	°C

Note 1: Voltage values are with respect to the anode terminal unless otherwise noted.

Note 2: T_j Max = 125°C

Note 3: Rating apply to ambient temperature at 25°C

Recommend Operating Condition

Cathode Voltage Range	Vka	Ref ~ 36	V
Cathode Current Range (for regulation)	I _k	1 ~ 100	mA

Electrical Characteristics

(T_a=25°C, unless otherwise specified.)

Parameter	Symbol	Test Conditions	Min	Typ	Max	Unit
Reference voltage	TS1431	V _{ref} Vka = V _{ref} , I _k =10mA (Figure 1)	2.446	2.495	2.545	V
	TS1431A		2.470		2.520	
	TS1431B		2.483		2.507	
Deviation of reference input voltage, over temp. (Note 4)	ΔV _{ref}	T _a = full range Vka = V _{ref} , I _k =10mA (Figure 1)	--	3	17	mV
Reference Input current	I _{ref}	R1=10KΩ, R2=∞, Ika=10mA (Figure 2)	--	0.7	4.0	uA
Ratio of change in V _{ref} to change in cathode Voltage	ΔV _{ref} / ΔVka	Ika=10mA, Vka = 10V to V _{ref} , Vka = 36V to 10V (Figure 2)	--	-1.4 -1.0	-2.7 -2.0	mV/V
Deviation of reference input current, over temp.	I _{ref} (DEV)	T _a = full range R1=10KΩ, R2=∞, Ika=10mA (Figure 2)	--	0.4	1.2	uA
Minimum operating cathode current	Ika(min)	Vka=V _{ref} (Figure 1)	--	0.4	0.6	mA
Off-state Cathode Current	I _{off}	V _{ref} =0V (Figure 3) Vka=36V	--	--	1.0	uA
Dynamic Output Impedance	Zka	f<1KHz, Vka=V _{ref} Ika=1mA to 100mA (Figure 1)	--	0.22	0.5	Ω

Electrical Characteristics (continued) (Ta=25 °C, unless otherwise specified.)

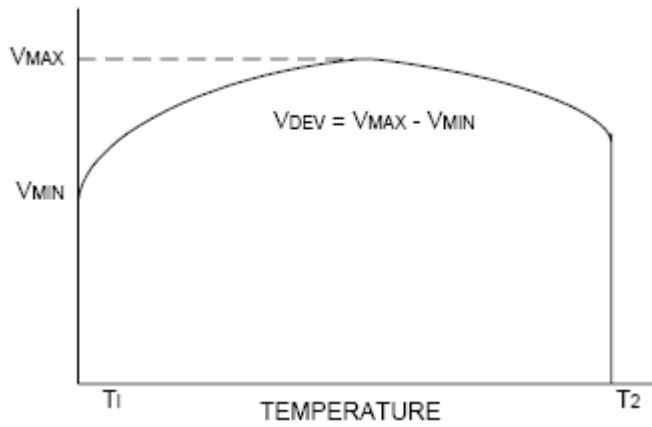

Note 4. Deviation of reference input voltage, VDEV, is defined as the maximum deviation of the reference over the full temperature range.

The average temperature coefficient of the reference input voltage αV_{ref} is defined as:

$$|\alpha V_{ref}| = [V_{DEV} / V_{ref}(25^\circ\text{C})] * 10^6 / T_2 - T_1 \dots\dots\dots (\text{PPM}/^\circ\text{C})$$

Where: **T2-T1** = full temperature change.

αV_{ref} can be positive or negative depending on whether the slope is positive or negative.

Example: Maximum Vref=2.496V at 30°C, minimum Vref=2.492V at 0°C, Vref=2.495V at 25°C, $\Delta T=70^\circ\text{C}$

$$|\alpha V_{ref}| = [4\text{mV} / 2495\text{mV}] * 10^6 / 70^\circ\text{C} \approx 23\text{ppm}/^\circ\text{C}$$

Note 5. The dynamic output impedance, R_z, is defined as:

$$|Z_{ka}| = \Delta V_{ka} / \Delta I_{ka}$$

When the device is programmed with two external resistors R1 and R2 (see Figure 2). The dynamic output impedance of the overall circuit, is defined as :

$$|Z_{ka}| = \Delta v / \Delta i \approx Z_{ka} | * (1 + R1 / R2)$$

Test Circuits

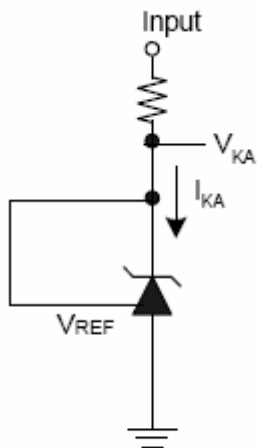
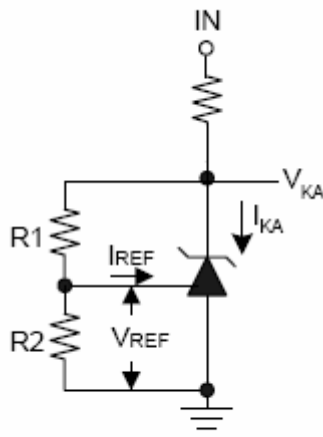

Figure 1. $V_{ka} = V_{ref}$



$$V_{ka} = V_{ref}(1+R1/R2)+I_{ref} * R1$$

Figure 2. $V_{ka} > V_{ref}$

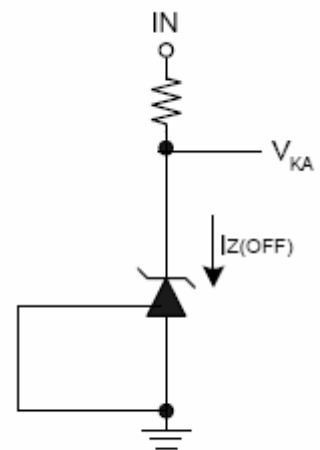
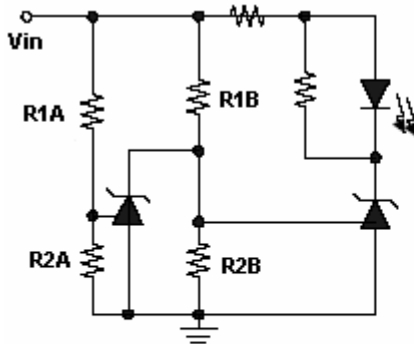

Figure 3. Off-state Current

Application Examples



LED on when low limit < Vin < high limit
 low limit = $V_{ref} (1 + R1B / R2B)$
 high limit = $V_{ref} (1 + R1A / R2A)$

Figure 4. Voltage Monitor

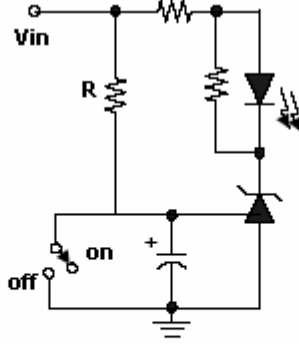

Delay = $RC \ln (V_{in} / (V_{in} - V_{ref}))$

Figure 5. Delay Timer

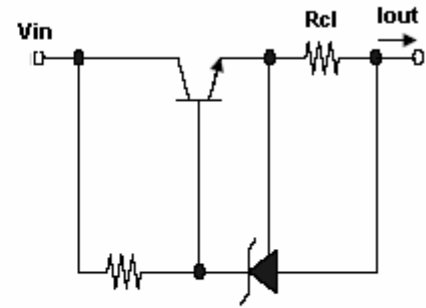

$I_{out} = V_{ref} / R_{cl}$

Figure 6. Current limiter or Current Source

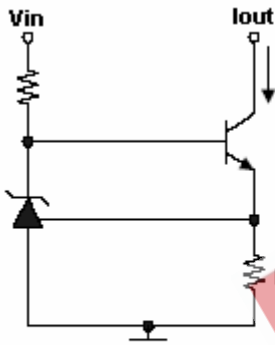

$I_{out} = V_{ref} / R_s$

Figure 7. Constant Current Sink

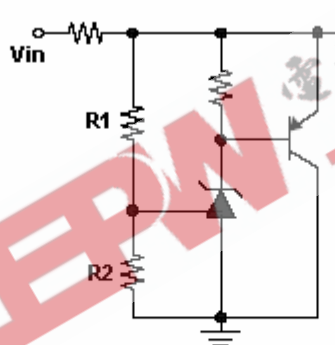

$V_{out} = V_{ref} * (1 + R1 / R2)$

Figure 8. Higher Current Shunt

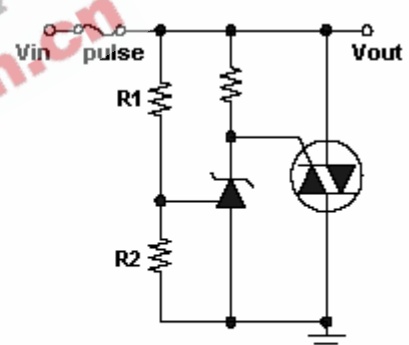

Limit = $V_{ref} * (1 + R1 / R2)$

Figure 9. Crow Bar

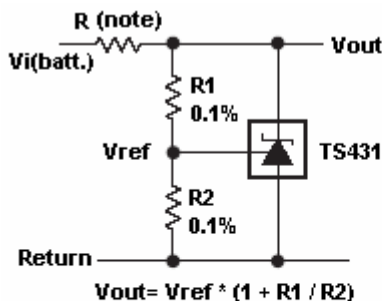

$V_{out} = V_{ref} * (1 + R1 / R2)$

note: R should provide cathode current > 1mA to the TS431 at minimum Vi(batt.)

Figure 10. Shunt Regulator

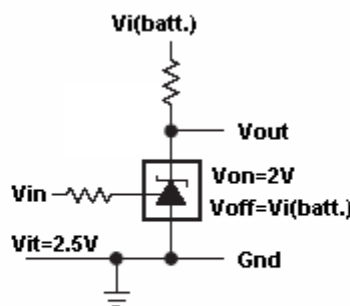
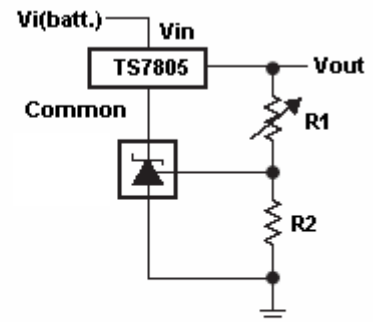

Figure 11. Single Supply Comparator v.s. Temp.-Compensated Threshold



$V_{out} = V_{ref} * (1 + R1 / R2)$
 minimum $V_{out} = V_{ref} + 5V$

Figure 12. Output Control of a Three-Terminal Fixed Regulator

Application Examples

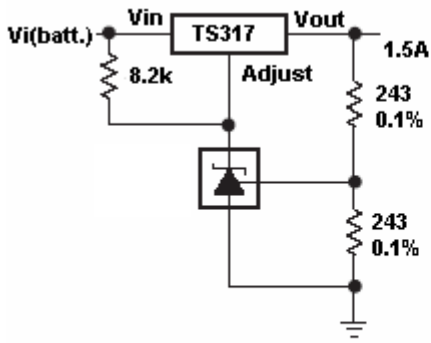
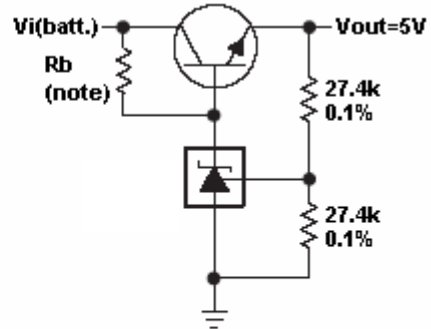
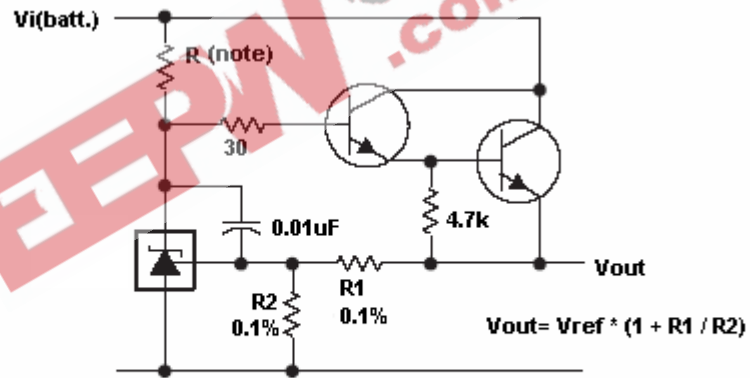

Figure 13. Precision 5V/1.5A regulator



note: Rb should provide cathode current >1mA to the TS431

Figure 14. Efficient 5V Precision Regulator



note: R should provide cathode current >1mA to the TS431 at minimum Vi(batt.)

Figure 15. Precision High Current Series Regulator

Typical Performance Characteristics

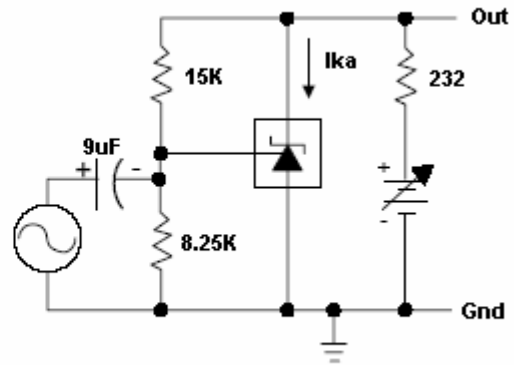
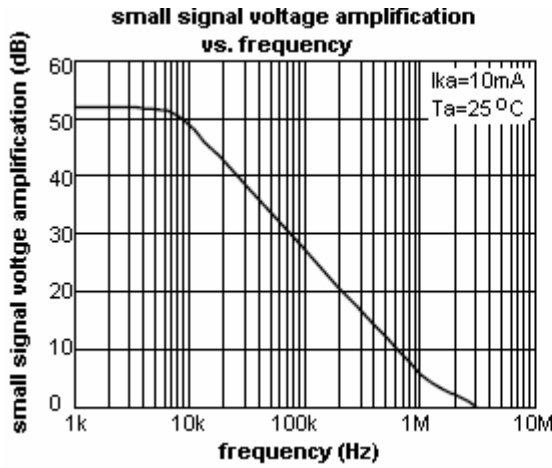

test circuit for voltage amplification

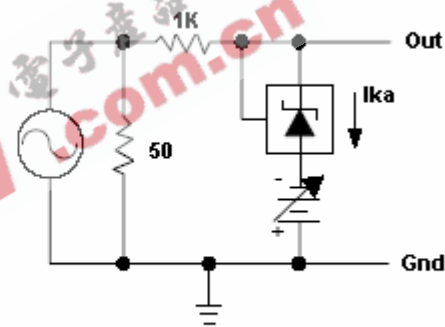
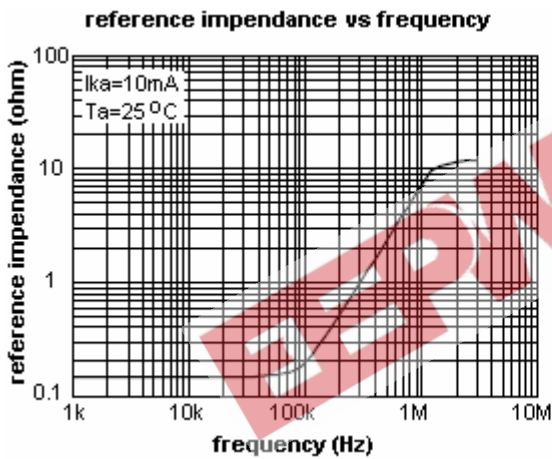

test circuit for reference impedance

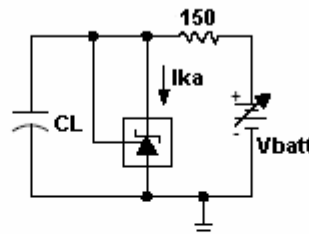
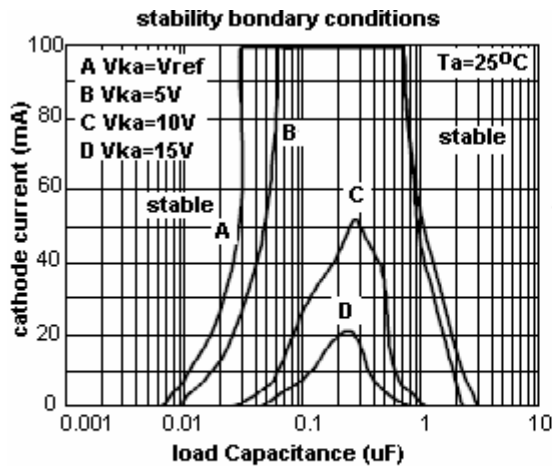

test circuit for curve A

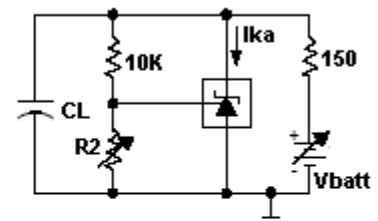

test circuit for curve B, C, D

the area under the curves represent conditions that may cause the device to oscillate. for curves B, C and D, R2 and V+ were adjusted to establish the initial V_{ka} and I_{ka} conditions with $CL=0$. V_{batt} and CL were then adjusted to determine the ranges of stability.

TO-92 Mechanical Drawing

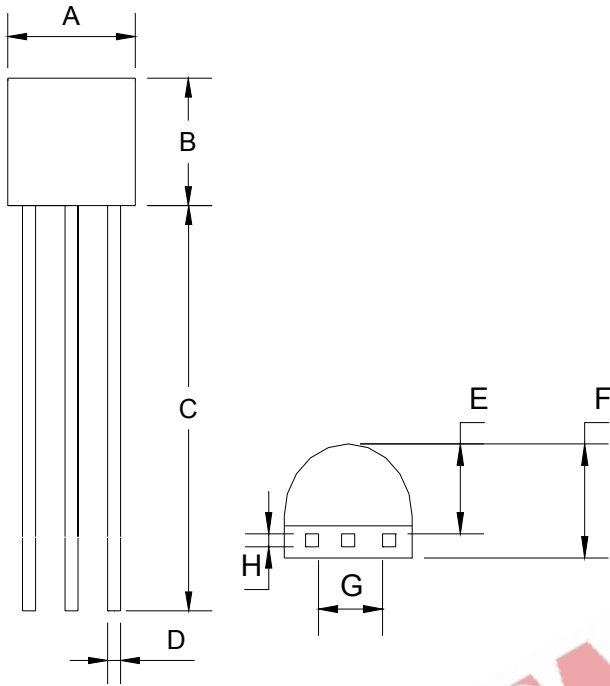

TO-92 DIMENSION				
DIM	MILLIMETERS		INCHES	
	MIN	MAX	MIN	MAX
A	4.30	4.70	0.169	0.185
B	4.30	4.70	0.169	0.185
C	14.30(typ)		0.563(typ)	
D	0.43	0.49	0.017	0.019
E	2.19	2.81	0.086	0.111
F	3.30	3.70	0.130	0.146
G	2.42	2.66	0.095	0.105
H	0.37	0.43	0.015	0.017

SOT-23 Mechanical Drawing

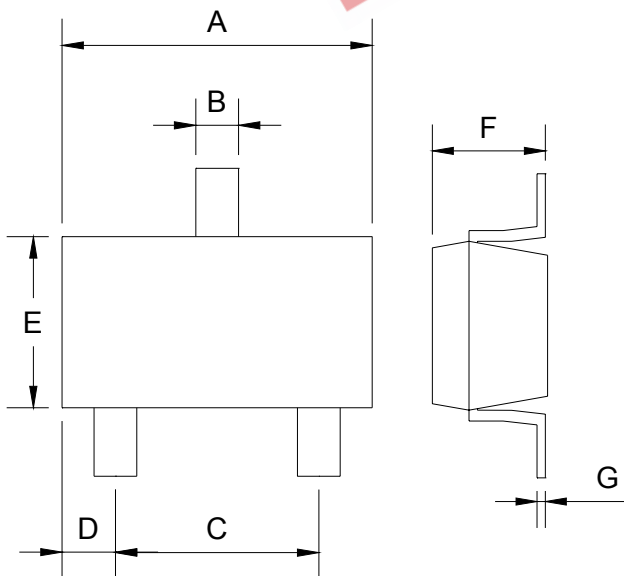

SOT-23 DIMENSION				
DIM	MILLIMETERS		INCHES	
	MIN	MAX	MIN	MAX
A	2.88	2.91	0.113	0.115
B	0.39	0.42	0.015	0.017
C	1.78	2.03	0.070	0.080
D	0.51	0.61	0.020	0.024
E	1.59	1.66	0.063	0.065
F	1.04	1.08	0.041	0.043
G	0.07	0.09	0.003	0.004