





TS9000/TS9000A

300mA CMOS Low Dropout Voltage Regulator

TO-92	Pin assignment	SOT-89	Pin assignment	SOT-23	Pin assignment
	TS9000		TS9000		TS9000
	1. Gnd 2. Input 3. Output		1. Gnd 2. Input 3. Output		1. Input 2. Output 3. Gnd
	TS9000A		TS9000A		TS9000A
1 2 3	1. Input 2. Gnd 3. Output	1 2 3	1. Output 2. Gnd 3. Input	1 2	1. Gnd 2. Output 3. Input

General Description

The TS9000/TS9000A series is a positive voltage regulator developed utilizing CMOS technology featured low quiescent current, low dropout voltage and high output voltage accuracy. Built in low on-resistor provides low dropout voltage and large output current. A 2.2uF or greater can be used as an output capacitor.

The TS9000/TS9000A series are prevented device failure under the worst operation condition with both thermal shutdown and current fold-back. These series are recommended for configuring portable devices and large current application, respectively.

This series are offered in 3-pin TO-92, SOT-89 and SOT-23 package.

Features

- ◇ Dropout voltage typically 0.4V @Io=300mA
- ◇ Output current up to 300mA
- ◇ Low quiescent current
- ◇ Output voltage trimmed before assembly
- ◇ Internal current limit
- ◇ Thermal shutdown protection

Applications

- ◇ Battery power equipment
- ◇ Personal communication devices
- ◇ Home electronic appliances
- ◇ PC peripherals
- ◇ CD-ROM
- ◇ Digital signal camera

Ordering Information

Part No.	Operating Temp. (Ambient)	Package
TS9000xCT	-40 ~ +85 °C	TO-92
TS9000xCX		SOT-23
TS9000xCY		SOT-89
TS9000AxCT		TO-92
TS9000AxCX		SOT-23
TS9000AxCY		SOT-89

Note: Where **x** denotes voltage option, available are
K=2.5V, **M**=2.7V, **N**=2.8V, **P**=3.0V,
S=3.3V, **U**=3.5V, **V**=3.6V, **X**=3.8V.
 Contact factory for additional voltage options.

Block Diagram

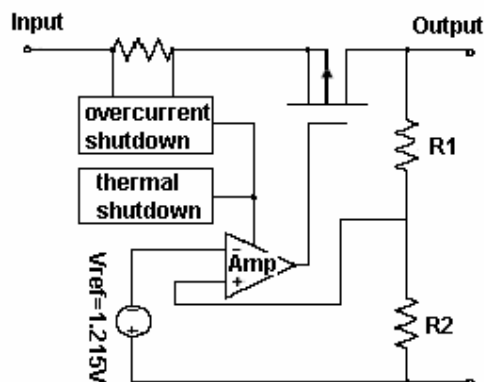

Typical Application Circuit

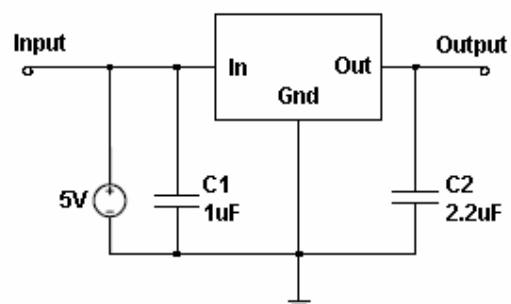



Absolute Maximum Rating

Input Supply Voltage	V _{in}	+7	V
Output Current	I _o	P _D / (V _{in} – V _o)	V
Power Dissipation	SOT-23	0.3	W
	SOT-89	0.5	
	TO-92	0.65	
Thermal Resistance	SOT-23	325	°C/W
	SOT-89	180	
	TO-92	160	
Operating Junction Temperature Range	T _j	-40 ~ +150	°C
Storage Temperature Range	T _{STG}	-65 ~ +150	°C
Lead Soldering Temperature (260 °C)		10	S

Caution: Stress above the listed absolute rating may cause permanent damage to the device.

Electrical Characteristics

T_a = 25 °C unless otherwise specified.

Parameter	Conditions	Min	Typ	Max	Unit
Output Voltage	V _{in} =V _o + 0.3V, 1mA ≤ I _o ≤ 300mA,	0.985 V _o		1.015 V _o	
Input Supply Voltage		V _o +0.3V	--	7	V
Output Voltage Temperature Coefficient		--	40	--	ppm/°C
Line Regulation	V _o +1V ≤ V _{in} ≤ V _o +2V, I _o =5mA	--	0.02	0.1	%
Load Regulation	1mA ≤ I _L ≤ 300mA	--	0.2	1.0	%
Dropout Voltage	I _o =300mA, V _o =V _o -2%	--	--	400	mV
Quiescent Current	V _{in} =5V, I _o =0A	--	30	50	μA
Short Circuit Current	V _{out} < 0.4V	--	300	400	mA
Output Noise		--	20	--	μV _{rms}
Power Supply Rejection Ratio	At 1KHz	--	55	--	dB

Detail Description

The TS9000/TS9000A series of CMOS regulators contain a P-MOS pass transistor, voltage reference, error amplifier, over current protection and thermal shutdown.

The TS9000/TS9000A series switches from voltage mode to current mode when the load exceeds the rated output current. This prevents over stress. The TS9000 also incorporates current fold-back to reduce power dissipation when the output is short circuit. This feature becomes active when the output drops below 0.8V, and reduces the current flow by 65%. Full current is restored when the voltage exceeds 0.8V.

The internal P-channel pass transistor receives data from the error amplifier, over current shutdown and thermal protection circuits. During normal operation, the error amplifier compares the output voltage to a precision reference. Over current and thermal shutdown circuits become active when the junction temperature exceeds 150 °C, or the current exceeds 300mA. During thermal shutdown, the output voltage remains low. Normal operation is restored when the junction temperature drops below 110 °C.

SOT-89 Mechanical Drawing

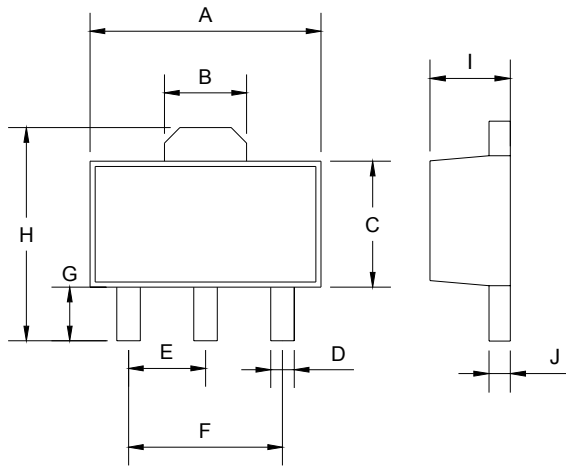

DIM	SOT-89 DIMENSION			
	MILLIMETERS		INCHES	
	MIN	MAX	MIN	MAX
A	4.40	4.60	0.173	0.181
B	1.50	1.7	0.059	0.070
C	2.30	2.60	0.090	0.102
D	0.40	0.52	0.016	0.020
E	1.50	1.50	0.059	0.059
F	3.00	3.00	0.118	0.118
G	0.89	1.20	0.035	0.047
H	4.05	4.25	0.159	0.167
I	1.4	1.6	0.055	0.068
J	0.35	0.44	0.014	0.017

SOT-23 Mechanical Drawing

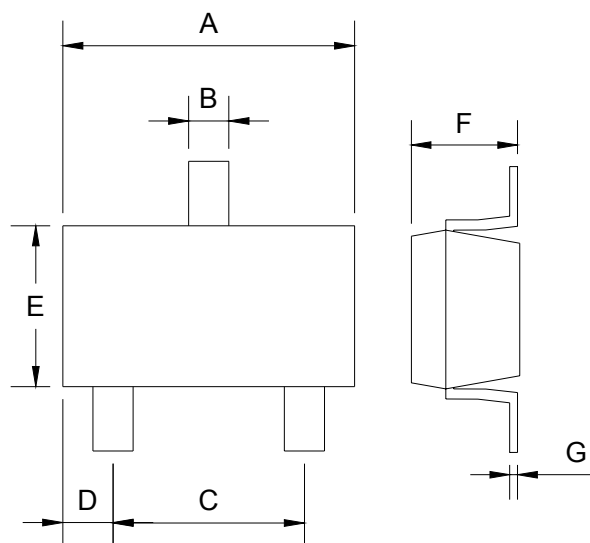

DIM	SOT-23 DIMENSION			
	MILLIMETERS		INCHES	
	MIN	MAX	MIN	MAX
A	2.88	2.91	0.113	0.115
B	0.39	0.42	0.015	0.017
C	1.78	2.03	0.070	0.080
D	0.51	0.61	0.020	0.024
E	1.50	1.70	0.059	0.067
F	1.04	1.08	0.041	0.043
G	0.07	0.09	0.003	0.004

TO-92 Mechanical Drawing

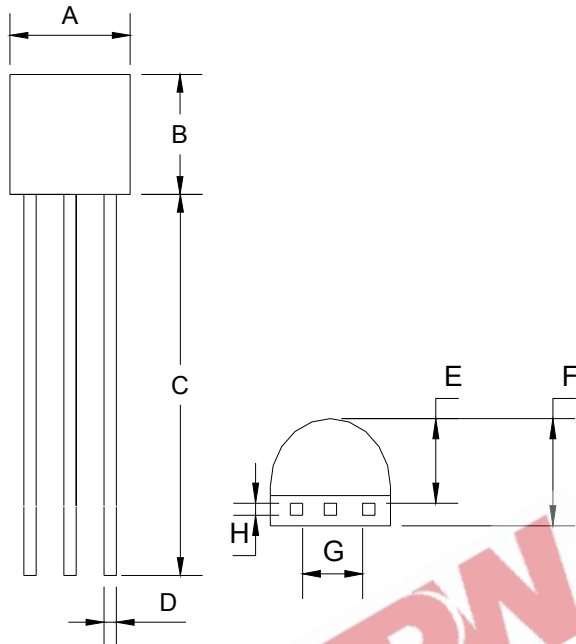

TO-92 DIMENSION				
DIM	MILLIMETERS		INCHES	
	MIN	MAX	MIN	MAX
A	4.30	4.70	0.169	0.185
B	4.30	4.70	0.169	0.185
C	14.30(typ)		0.563(typ)	
D	0.43	0.49	0.017	0.019
E	2.19	2.81	0.086	0.111
F	3.30	3.70	0.130	0.146
G	2.42	2.66	0.095	0.105
H	0.37	0.43	0.015	0.017

EEPW.com.cn 电子产品世界