



# TS278R00

## 2A Ultra Low Dropout Voltage Regulator w/Disable

ITO-220-4L



ITO-220-4SL



Pin assignment:

1. Input
2. Output
3. Gnd
4. Enable

**Low Dropout Voltage 0.5V max.**

### General Description

The TS278R00 Series is a low-dropout voltage regulator suitable for various electronic equipments. It provides constant voltage power source with ITO-220 4 lead full mold package.

Dropout voltage of TS278R00 Series is below 0.5V in full rated current (2A). This regulator has various functions such as a peak current protection, thermal shut down, over voltage protection and an output disable function.

### Features

- ✧ Ultra Low Dropout performance 0.5Vmax. 2A
- ✧ Over Current Protection, Thermal Shutdown
- ✧ Over Voltage Protection, Short Circuit Protection
- ✧ With Output Disable Function
- ✧  $\pm 2.4\%$  Typical Total output
- ✧ TO-220 Full-Mold Package (4Pin)

### Ordering Information

Part No.	Operating Temp.	Package
TS278RxxCI4	-40 ~ 125 °C	ITO-220-4L
TS278RxxCI4S		ITO-220-4SL

Note: Where xx denotes voltage option,  
33=3.3V, 05=5.0V, 08=8.0V, 09=9.0V, 12=12V

### Block Diagram

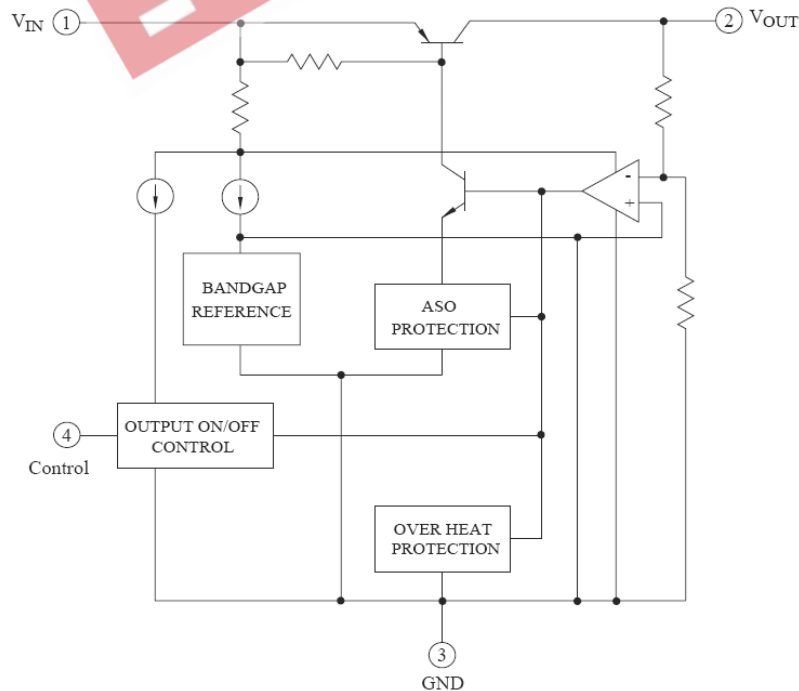



Absolute Maximum Ratings							
Parameter		Symbol	Value	Unit	Remark		
Input Voltage		Vin	30	V	--		
Disable Voltage		Vdis	30	V	--		
Output Current		Io	2.0	A	--		
Power Dissipation 1		Pd1	1.5	W	No heat sink		
Power Dissipation 2		Pd2	15	W	With heat sink		
Junction Temperature		Tj	-40~+125	°C	--		
Thermal Resistance, Junction-to Case(Note2)		Rθjc	4.31	°C / W	--		
Thermal Resistance, Junction-to Air(Note2)		Rθja	48.83	°C / W	--		
Thermal Shutdown Temperature		Ttsd	150	°C	--		
Electrical Characteristics							
TS278R00 Series (Vin=Note 6, Io=1.0A, Ta=25°C , unless otherwise specified).							
Parameter		Symbol	Conditions	Min.	Typ.	Max.	Unit
Output Voltage	TS278R33	Vo		3.22	3.3	3.38	V
	TS278R05			4.88	5.0	5.12	
	TS278R08			7.80	8.0	8.20	
	TS278R09			8.78	9.0	9.22	
	TS278R12			11.7	12	12.3	
Load Regulation		REGload	5mA<Io<2A	--	0.1	2.0	%
Line Regulation		REGline	Note 7	--	0.5	2.5	%
Ripple Rejection Ratio		RR	Note1	45	55	--	dB
Dropout Voltage		Vdrop	Io=2A	--	--	0.5	V
Disable Voltage High		VdisH	Output Active	2.0	--	--	V
Disable Voltage Low		VdisL	Output Disabled	--	--	0.8	V
Disable Bias Current High		IdisH	Vdis=2.7V	--	--	20	uA
Disable Bias Current Low		IdisL	Vdis=0.4V	--	--	-0.4	mA
Quiescent Current		Iq	Io=0A	--	--	10	mA
<p><b>Note:</b> 1. These parameters, although guaranteed, are not 100% tested in production.</p> <p>2. Junction -to -case thermal resistance test environments.</p> <p>3. Pneumatic heat sink fixture.</p> <p>4. Clamping pressure 60psi through 12mm diameter cylinder.</p> <p>5. Thermal grease applied between PKG and heat sink fixture</p> <p>6. TS278R33: Vin=5V, TS278R05: Vin=7V, TS278R08: Vin=10V, TS278R09: Vin=11V, TS278R12: Vin=15V</p> <p>7. TS278R33: Vin=4~10V, TS278R05: Vin=6~12V, TS278R08: Vin=9~25V, TS278R09: Vin=10~25V, TS278R12: Vin=13~29V</p>							

### Standard Test Circuit

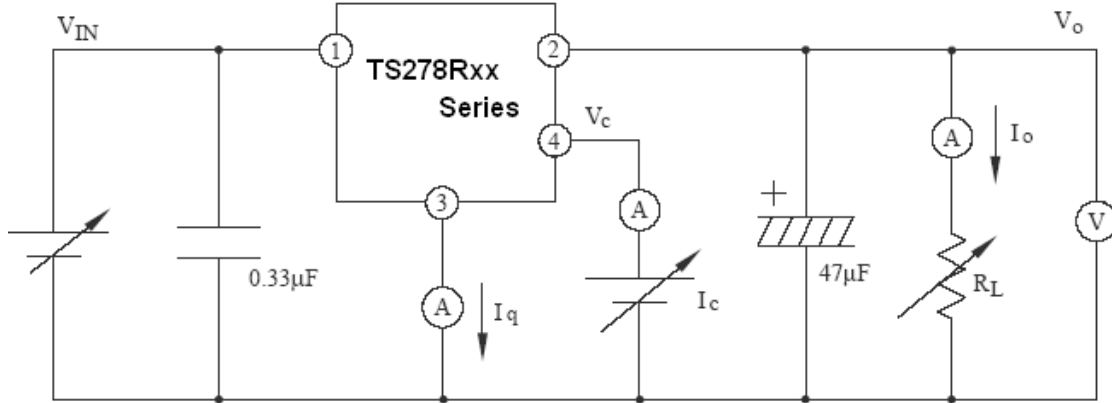

### Ripple Rejection Test Circuit

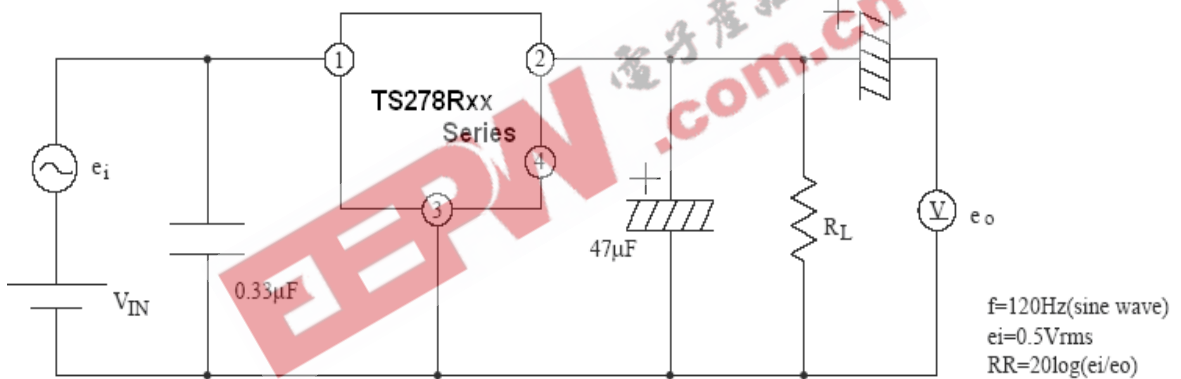

### Standard Application Circuit

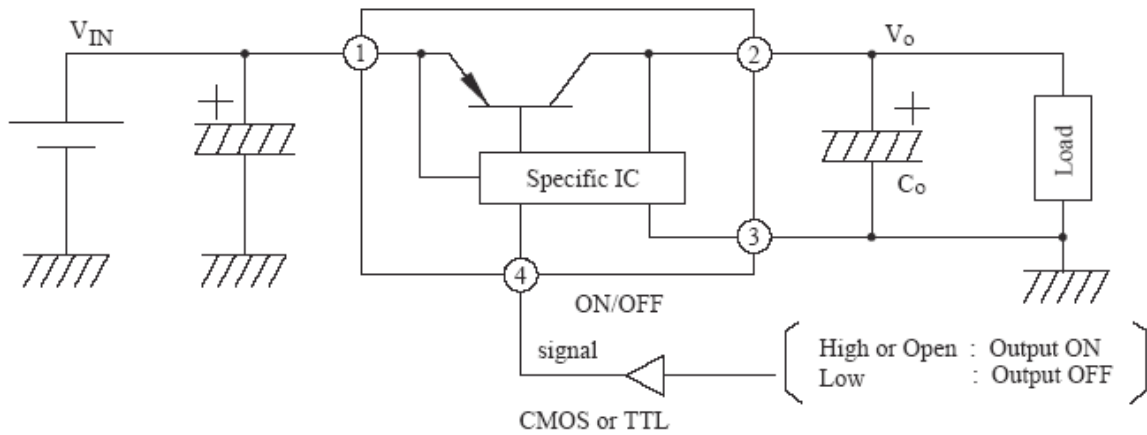

### ITO-220-4L Mechanical Drawing

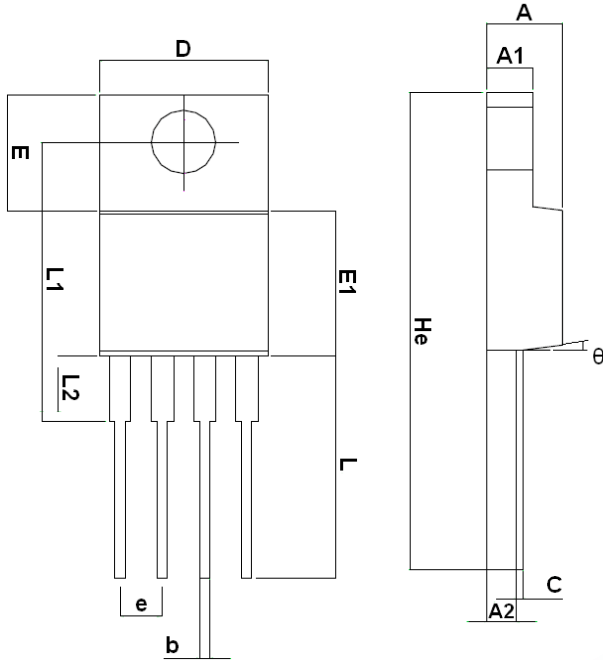

ITO-220-4L DIMENSION				
DIM	MILLIMETERS		INCHES	
	MIN	MAX	MIN	MAX
A	4.42	4.72	0.174	0.186
A1	2.69	2.89	0.136	0.114
A2	1.68	1.88	0.066	0.074
D	10.00	10.20	0.394	0.402
E	6.85	7.05	0.269	0.278
E1	8.54	8.74	0.336	0.344
L	13.15	13.55	0.518	0.533
L2	16.56	16.76	0.652	0.660
L2	3.60	3.80	0.142	0.150
He	28.44	28.92	1.119	1.159
C	0.48		0.019	
E	2.54(TYP)		0.1(TYP)	
b	0.635(TYP)		0.025(TYP)	
$\theta$	4°	7°	4°	7°

### ITO-220-4SL Mechanical Drawing

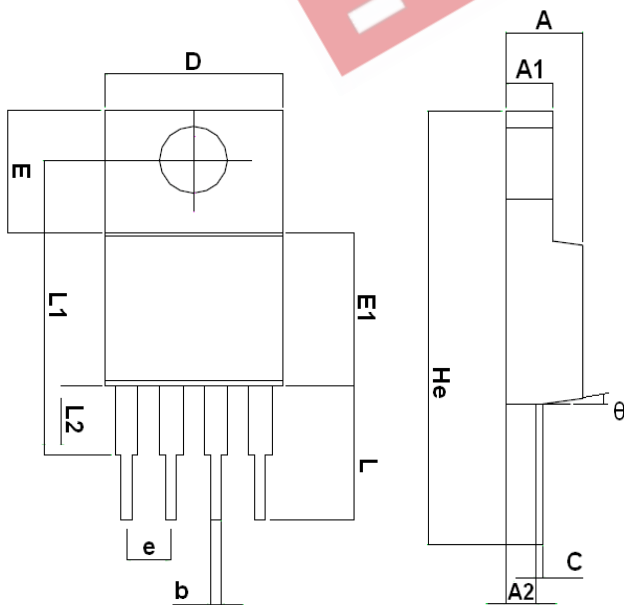

ITO-220-4SL DIMENSION				
DIM	MILLIMETERS		INCHES	
	MIN	MAX	MIN	MAX
A	4.42	4.72	0.174	0.186
A1	2.69	2.89	0.136	0.114
A2	1.68	1.88	0.066	0.074
D	10.00	10.20	0.394	0.402
E	6.85	7.05	0.269	0.278
E1	8.54	8.74	0.336	0.344
L	8.32	8.72	0.328	0.343
L2	16.56	16.76	0.652	0.660
L2	3.60	3.80	0.142	0.150
He	23.72	24.72	0.934	0.973
C	0.48		0.019	
E	2.54(TYP)		0.1(TYP)	
b	0.635(TYP)		0.025(TYP)	
$\theta$	4°	7°	4°	7°