

**TO-92**



**Pin Definition:**

- 1. Cathode
- 2. Anode
- 3. Reference

**SOT-23**



**Pin Definition:**

- 1. Cathode
- 2. Reference
- 3. Anode

**General Description**

TS1431 series integrated circuits are three-terminal programmable shunt regulator diodes. These monolithic IC voltage references operate as a low temperature coefficient zener which is programmable from Vref to 36 volts with two external resistors. These devices exhibit a wide operating current range of 1.0 to 100mA with a typical dynamic impedance of 0.22Ω. The characteristics of these references make them excellent replacements for zener diodes in many applications such as digital voltmeters, power supplies, and op amp circuitry. The 2.5V reference makes it convenient to obtain a stable reference from 5.0V logic supplies, and since The TS1431 series operates as a shunt regulator, it can be used as either a positive or negative stage reference.

**Features**

- Precision Reference Voltage  
 TS1431 – 2.495V±2%  
 TS1431A – 2.495V±1%  
 TS1431B – 2.495V±0.5%
- Equivalent Full Range Temp. Coefficient: 50ppm/°C
- Programmable Output Voltage up to 36V
- Fast Turn-On Response
- Sink Current Capability of 1~100mA
- Low Dynamic Output Impedance: 0.2Ω
- Low Output Noise

**Ordering Information**

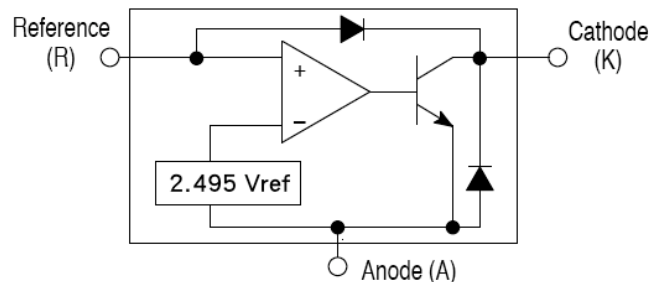
Part No.	Package	Packing
TS1431xCT B0	TO-92	1Kpcs / Bulk
TS1431xCT A3	TO-92	2Kpcs / Ammo
TS1431xCX RF	SOT-23	3Kpcs / 7" Reel
TS1431xCT B0G	TO-92	1Kpcs / Bulk
TS1431xCT A3G	TO-92	2Kpcs / Ammo
TS1431xCX RFG	SOT-23	3Kpcs / 7" Reel

Note: "G" denote for Green Product  
 Where **xx** denotes voltage tolerance  
**Blank:** ±2%, **A:** ±1%, **B:** ±0.5%

**Application**

- Voltage Monitor
- Delay Timmer
- Constant –Current Source/Sink
- High-Current Shunt Regulator
- Crow Bar
- Over-Voltage / Under-Voltage Protection

**Block Diagram**



**Absolute Maximum Rating** (Ta = 25°C unless otherwise noted)

Parameter	Symbol	Limit	Unit
Cathode Voltage	Vka	36	V
Continuous Cathode Current Range	Ik	1 ~ +100	mA
Reference Input Current Range	Iref	-0.05 ~ +10	mA
Power Dissipation	Pd	TO-92	0.625
		SOT-23	0.30
Junction Temperature	Tj	+150	°C
Operating Temperature Range	Toper	0 ~ +70	°C
Storage Temperature Range	Tstg	-65 ~ +150	°C

### Recommend Operating Condition

Parameter	Symbol	Limit	Unit
Cathode Voltage (Note 1)	$V_{KA}$	Ref ~ 36	V
Continuous Cathode Current Range	$I_K$	1 ~ 100	mA

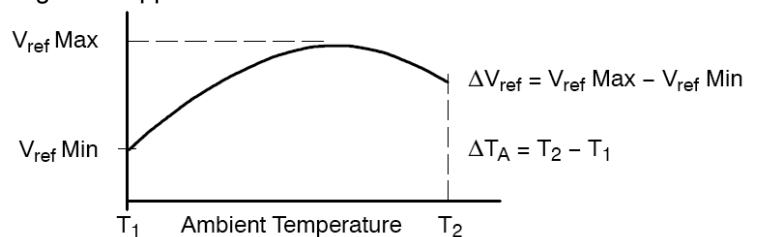
### Recommend Operating Condition

Parameter	Symbol	Test Conditions	Min	Typ	Max	Unit
Reference voltage	$V_{REF}$	$V_{KA} = V_{REF}$ , $I_K = 10\text{mA}$ (Figure 1) $T_a = 25^\circ\text{C}$	2.450	2.495	2.550	V
			2.475		2.525	
			2.487		2.513	
Deviation of reference input voltage	$\Delta V_{REF}$	$V_{KA} = V_{REF}$ , $I_K = 10\text{mA}$ (Figure 1) $T_a = \text{full range}$	--	3	17	mV
Radio of change in Vref to change in cathode Voltage	$\Delta V_{REF} / \Delta V_{KA}$	$I_{KA} = 10\text{mA}$ , $V_{KA} = 10\text{V to } V_{REF}$ $V_{KA} = 36\text{V to } 10\text{V}$ (Figure 2)	--	-1.4 -1.0	-2.7 -2.0	mV/V
Reference Input current	$I_{REF}$	$R1=10\text{K}\Omega$ , $R2 = \infty$ , $I_{KA} = 10\text{mA}$ $T_a = \text{full range}$ (Figure 2)	--	0.7	4.0	$\mu\text{A}$
Deviation of reference input current, over temp.	$\Delta I_{REF}$	$R1=10\text{K}\Omega$ , $R2 = \infty$ , $I_{KA} = 10\text{mA}$ $T_a = \text{full range}$ (Figure 2)	--	0.4	1.2	$\mu\text{A}$
Off-state Cathode Current	$I_{KA} (\text{off})$	$V_{REF} = 0\text{V}$ (Figure 3), $V_{KA} = 36\text{V}$	--	--	1.0	$\mu\text{A}$
Dynamic Output Impedance	$ Z_{KA} $	$f < 1\text{KHz}$ , $V_{KA} = V_{REF}$ $I_{KA} = 1\text{mA to } 100\text{mA}$ (Figure 1)	--	0.22	0.5	$\Omega$
Minimum operating cathode current	$I_{KA} (\text{min})$	$V_{KA} = V_{REF}$ (Figure 1)	--	0.4	0.6	mA

\* The deviation parameters  $\Delta V_{REF}$  and  $\Delta I_{REF}$  are defined as difference between the maximum value and minimum value obtained over the full operating ambient temperature range that applied.

\* The average temperature coefficient of the reference input voltage,  $\alpha V_{REF}$  is defined as:

$$\alpha V_{REF} \left( \frac{\text{ppm}}{^\circ\text{C}} \right) = \frac{\left( \frac{\Delta V_{REF}}{V_{REF}} \right) \times 10^6}{\Delta T_A} \quad \left( T_A = 25^\circ\text{C} \right)$$



Where:  $T_2 - T_1$  = full temperature change.

$\alpha V_{REF}$  can be positive or negative depending on whether the slope is positive or negative.

Example: Maximum  $V_{REF} = 2.496\text{V}$  at  $30^\circ\text{C}$ , minimum  $V_{REF} = 2.492\text{V}$  at  $0^\circ\text{C}$ ,  $V_{REF} = 2.495\text{V}$  at  $25^\circ\text{C}$ ,  $\Delta T = 70^\circ\text{C}$

$$\alpha V_{REF} = [4\text{mV} / 2495\text{mV}] * 10^6 / 70^\circ\text{C} \approx 23\text{ppm}/^\circ\text{C}$$

Because minimum  $V_{REF}$  occurs at the lower temperature, the coefficient is positive.

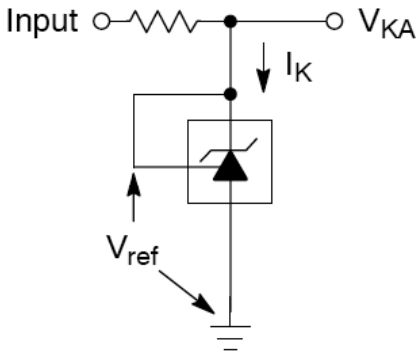
\* The dynamic impedance  $Z_{KA}$  is defined as:

$$|Z_{KA}| = \Delta V_{KA} / \Delta I_{KA}$$

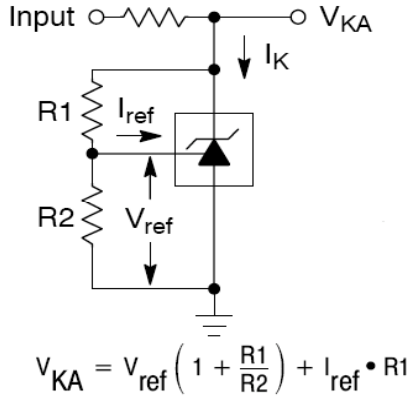
\* When the device operating with two external resistors,  $R_1$  and  $R_2$ , (refer to Figure 2) the total dynamic impedance of the circuit is given by:

$$|Z_{KA}| = \Delta V / \Delta I \approx Z_{KA} * (1 + R_1 / R_2)$$

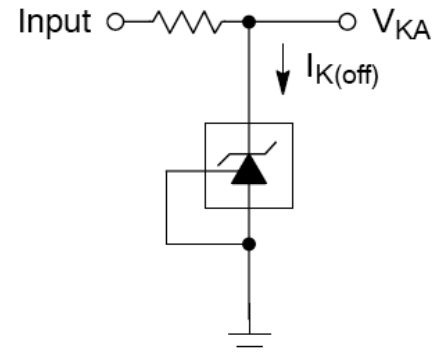
### Test Circuits



**Figure 1:  $V_{KA} = V_{REF}$**



**Figure 2:  $V_{KA} > V_{REF}$**



**Figure 3: Off-State Current**

### Additional Information – Stability

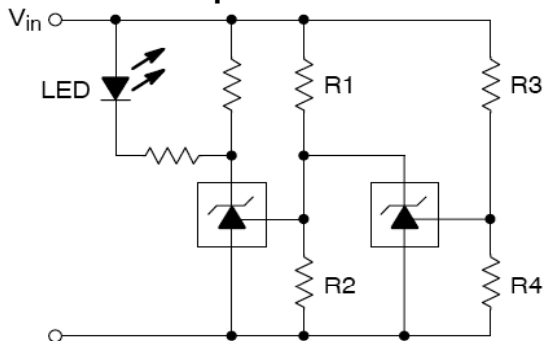
When The TS1431/1431A/1431B is used as a shunt regulator, there are two options for selection of  $C_L$ , are recommended for optional stability:

- A) No load capacitance across the device, decouple at the load.
- B) Large capacitance across the device, optional decoupling at the load.

The reason for this is that TS1431/1431A/1431B exhibits instability with capacitances in the range of 10nF to 1uF (approx.) at light cathode current up to 3mA (typ). The device is less stable the lower the cathode voltage has been set for. Therefore while the device will be perfectly stable operating at a cathode current of 10mA (approx.) with a 0.1uF capacitor across it, it will oscillate transiently during start up as the cathode current passes through the instability region. Select a very low capacitance, or alternatively a high capacitance (10uF) will avoid this issue altogether. Since the user will probably wish to have local decoupling at the load anyway, the most cost effective method is to use no capacitance at all directly across the device. PCB trace/via resistance and inductance prevent the local load decoupling from causing the oscillation during the transient start up phase.

Note: if the TS1431/1431A/1431B is located right at the load, so the load decoupling capacitor is directly across it, then this capacitor will have to be  $\leq 1nF$  or  $\geq 10uF$ .

### Applications Examples

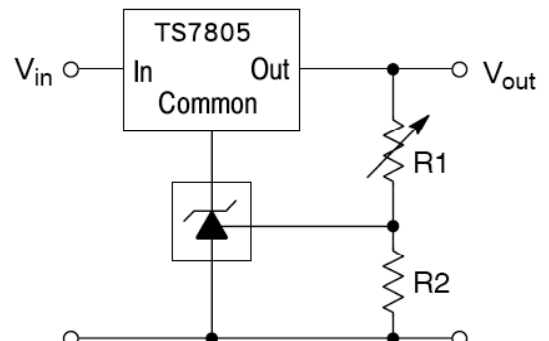


L.E.D. indicator is 'ON' when  $V_{in}$  is between the upper and lower limits,

$$\text{Lower limit} = \left(1 + \frac{R1}{R2}\right) V_{ref}$$

$$\text{Upper limit} = \left(1 + \frac{R3}{R4}\right) V_{ref}$$

**Figure 4: Voltage Monitor**

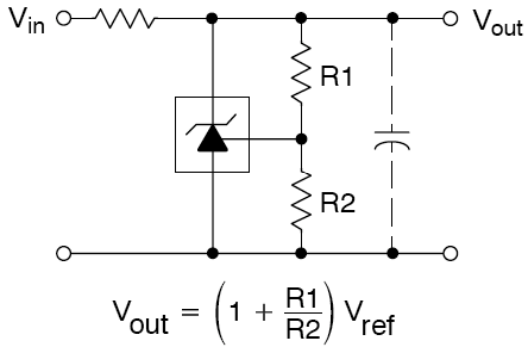


$$V_{out} = \left(1 + \frac{R1}{R2}\right) V_{ref}$$

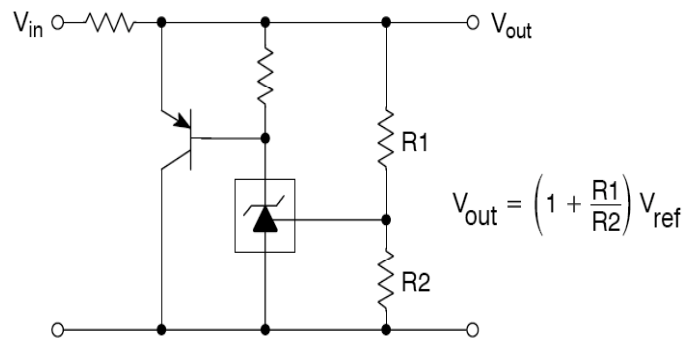
$$V_{out(min)} = V_{ref} + 5.0 V$$

**Figure 5: Output Control for Three Terminal Fixed Regulator**

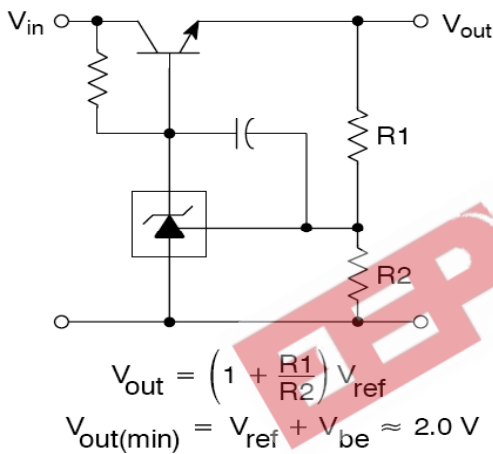
**Applications Examples (Continue)**



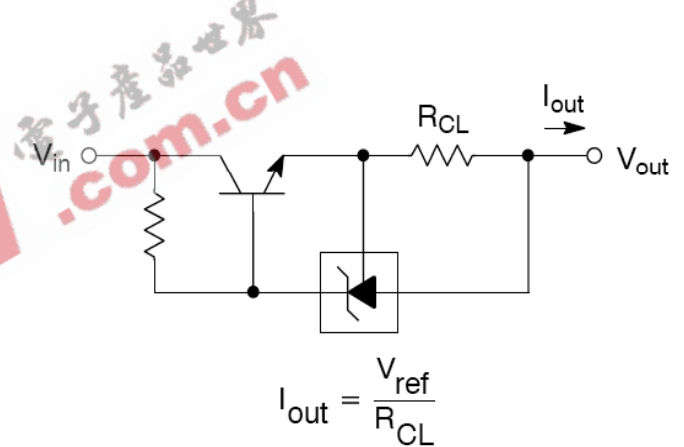
**Figure 6: Shunt Regulator**



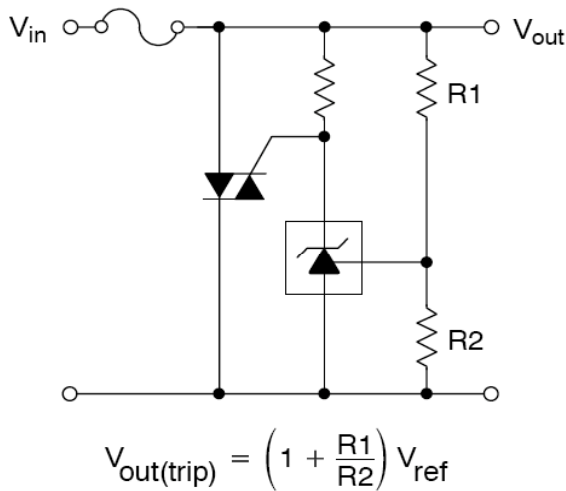
**Figure 7: High Current Shunt Regulator**



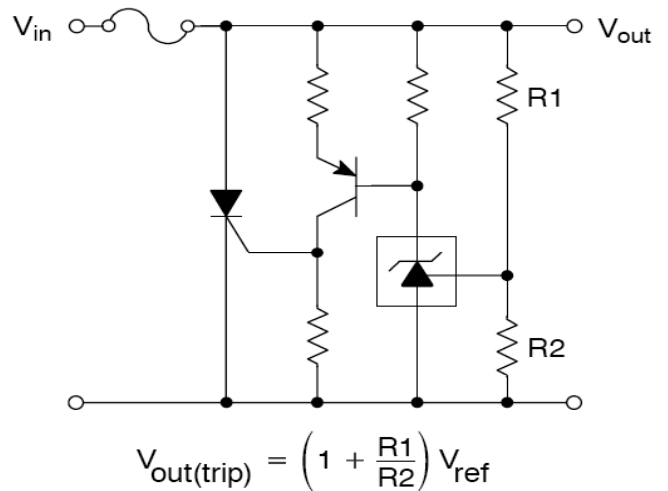
**Figure 8: Series Pass Regulator**



**Figure 9: Constant Current Source**

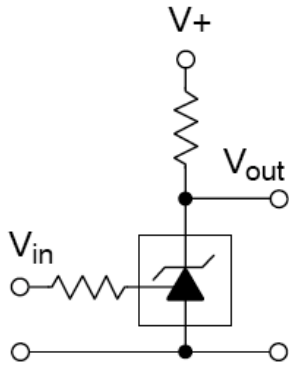


**Figure 10: TRIAC Crowbar**



**Figure 11: SCR Crowbar**

Applications Examples (Continue)



V <sub>in</sub>	V <sub>out</sub>
<V <sub>ref</sub>	V <sub>+</sub>
>V <sub>ref</sub>	≈0.74V

Figure 12: Single-Supply Comparator with Temperature-Compensated Threshold

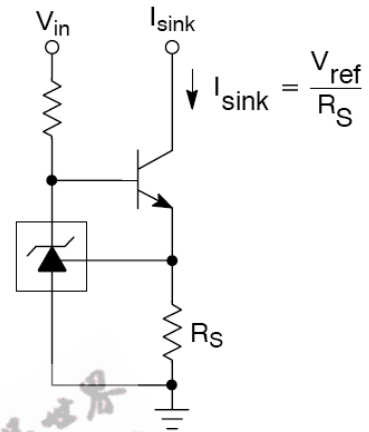
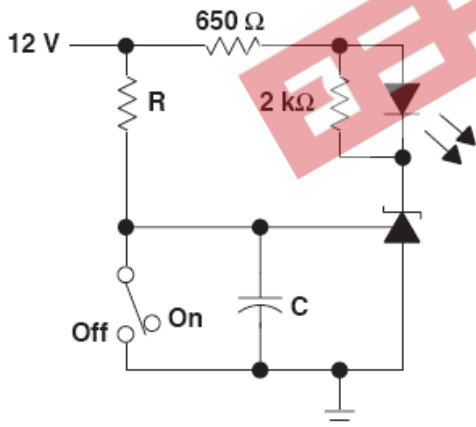


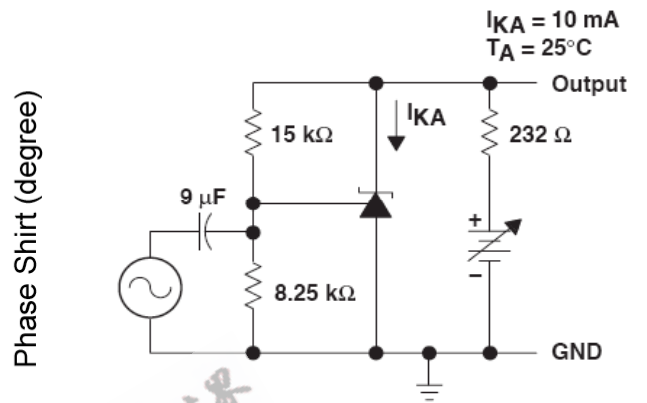
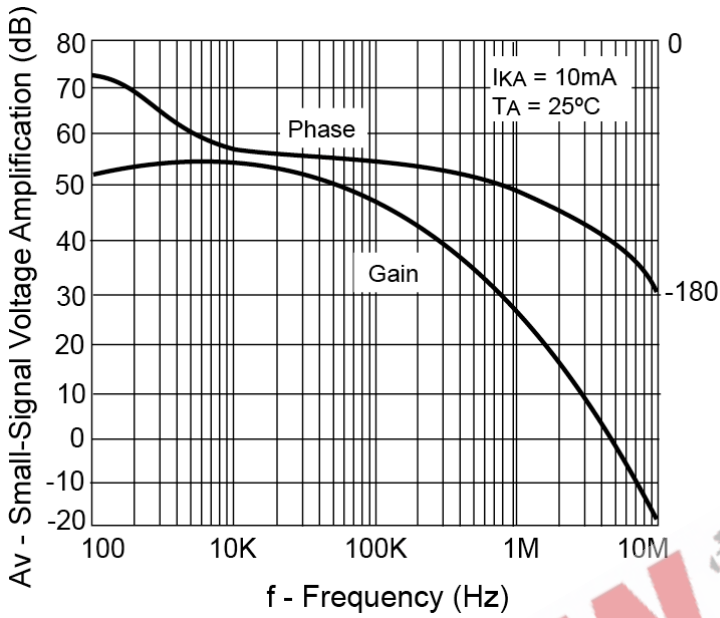
Figure 13: Constant Current Sink



$$\text{Delay} = R \times C \times I_n \left( \frac{12 \text{ V}}{12 \text{ V} - V_{\text{ref}}} \right)$$

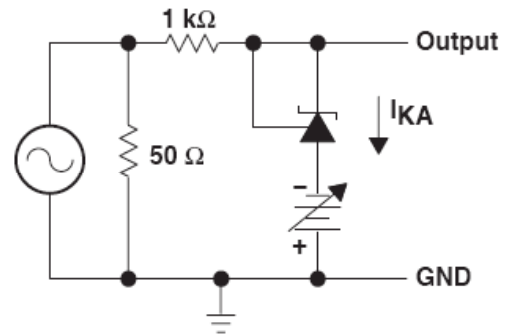
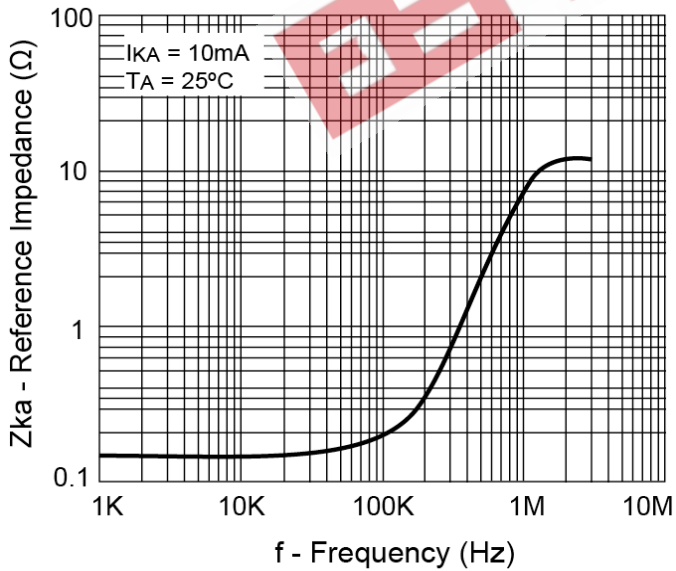
Figure 14: Delay Timer

**Typical Performance Characteristics**



Test Circuit for Voltage Amplification

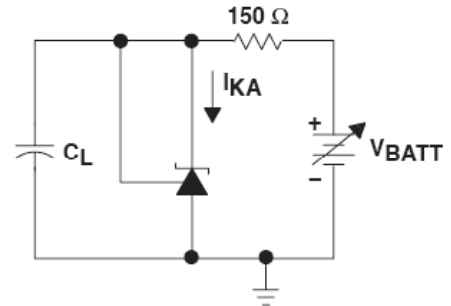
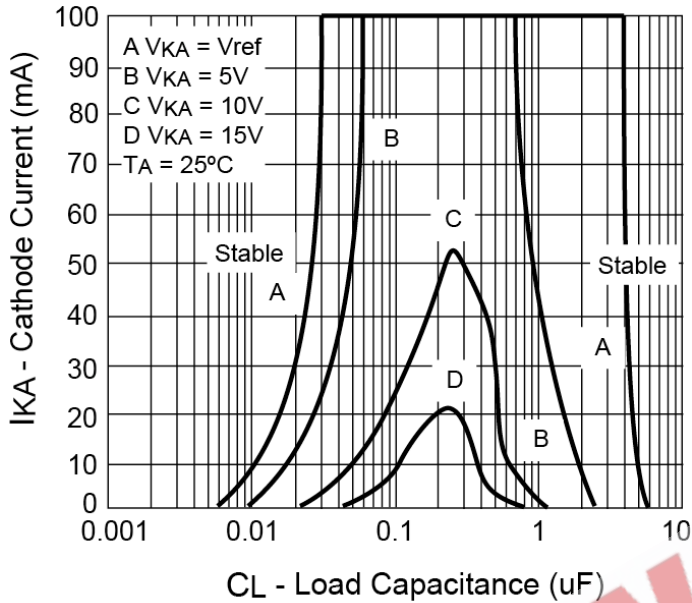
**Figure 14: Small-Signal Voltage Gain and Phase Shift vs. Frequency**



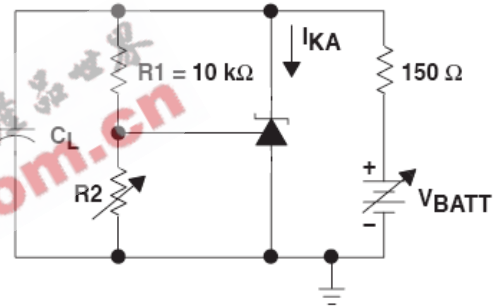
Test Circuit for Reference Impedance

**Figure 15: Reference Impedance vs. Frequency**

### Typical Performance Characteristics (Continue)



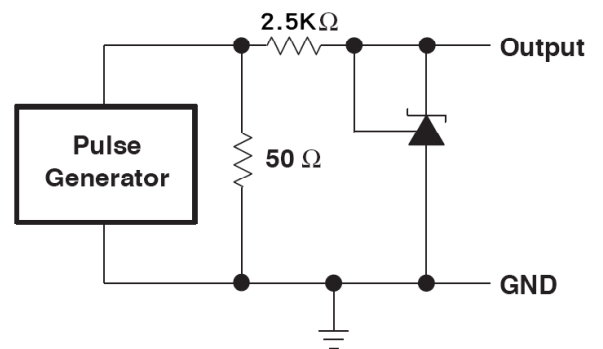
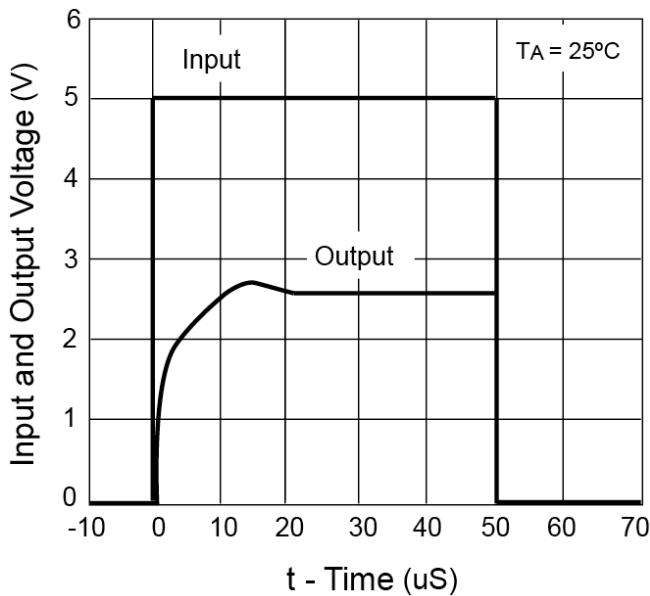
Test Circuit for Curve A



Test Circuit for Curve B, C and D

The areas under the curves represent conditions that may cause the device to oscillate. For curves B, C, and D,  $R_2$  and  $V_+$  were adjusted to establish the initial  $V_{KA}$  and  $I_{KA}$  conditions with  $C_L=0$ .  $V_{BATT}$  and  $C_L$  then were adjusted to determine the ranges of stability.

Figure 16: Stability Boundary Condition



Test Circuit for Pulse Response,  $I_k=1mA$

Figure 17: Pulse Response

### Electrical Characteristics

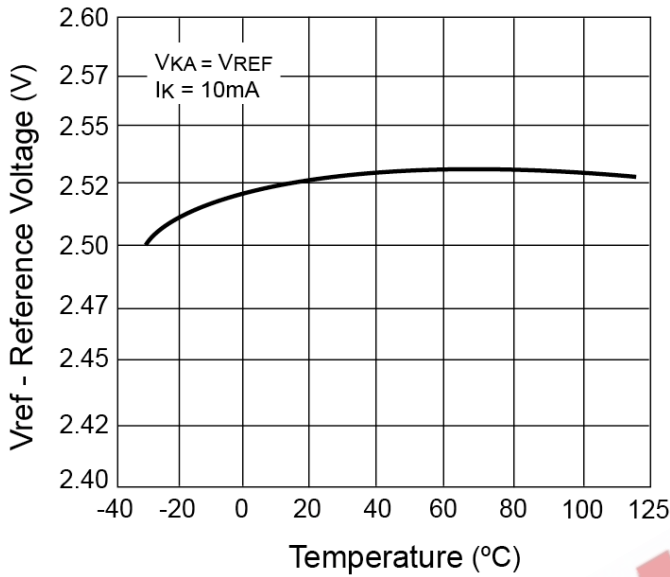


Figure 18: Reference Voltage vs. Temperature

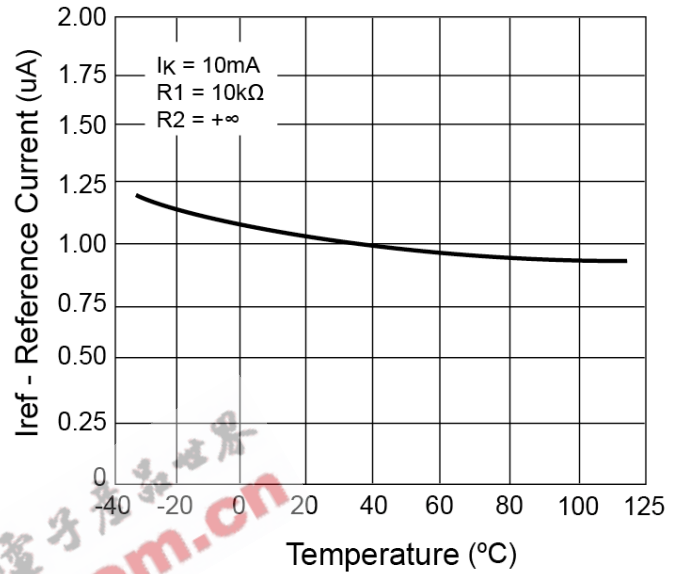


Figure 19: Reference Current vs. Temperature

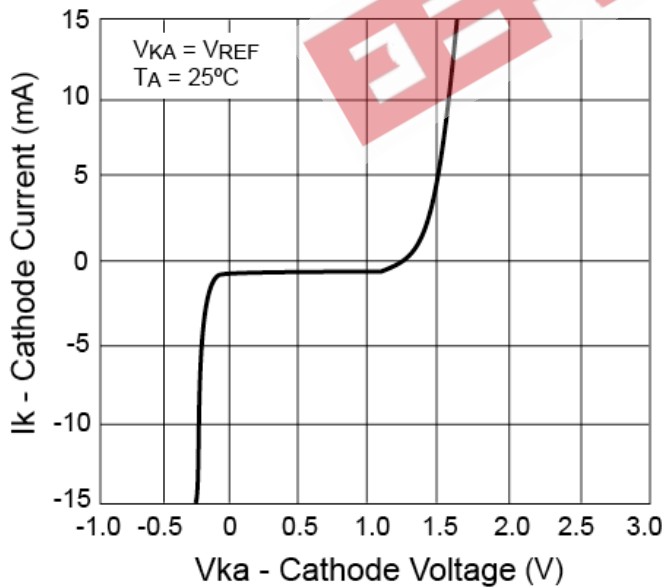
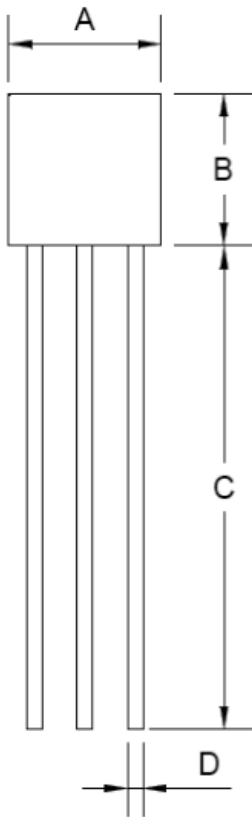


Figure 20: Cathode Current vs. Cathode Voltage

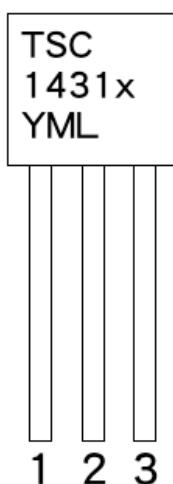


### TO-92 Mechanical Drawing



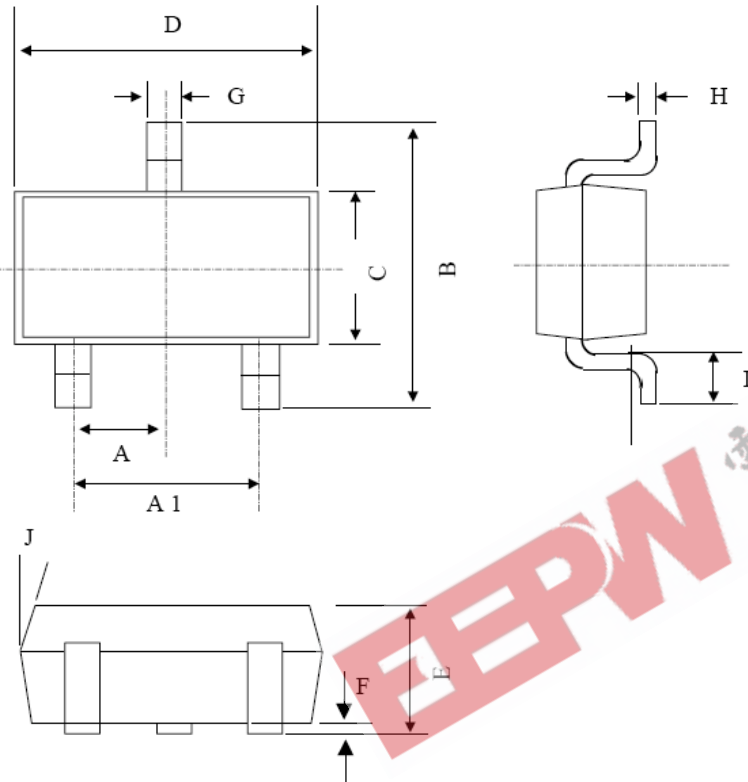
DIM	MILLIMETERS		INCHES	
	MIN	MAX	MIN	MAX
A	4.30	4.70	0.169	0.185
B	4.30	4.70	0.169	0.185
C	14.30(typ)		0.563(typ)	
D	0.43	0.49	0.017	0.019
E	2.19	2.81	0.086	0.111
F	3.30	3.70	0.130	0.146
G	2.42	2.66	0.095	0.105
H	0.37	0.43	0.015	0.017

### Marking Diagram



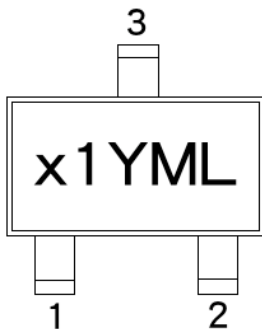
- X** = Tolerance Code  
(**A** = ±1%, **B** = ±0.5%, **Blank** = ±2%,)
- Y** = Year Code
- M** = Month Code  
(**A**=Jan, **B**=Feb, **C**=Mar, **D**=Apr, **E**=May, **F**=Jun, **G**=Jul, **H**=Aug, **I**=Sep, **J**=Oct, **K**=Nov, **L**=Dec)
- L** = Lot Code

**SOT-23 Mechanical Drawing**



DIM	SOT-23 DIMENSION			
	MILLIMETERS		INCHES	
	MIN	MAX	MIN	MAX.
A	0.95 BSC		0.037 BSC	
A1	1.9 BSC		0.074 BSC	
B	2.60	3.00	0.102	0.118
C	1.40	1.70	0.055	0.067
D	2.80	3.10	0.110	0.122
E	1.00	1.30	0.039	0.051
F	0.00	0.10	0.000	0.004
G	0.35	0.50	0.014	0.020
H	0.10	0.20	0.004	0.008
I	0.30	0.60	0.012	0.024
J	5°	10°	5°	10°

**Marking Diagram**



- 1** = Device Code
- X** = Tolerance Code  
(A = ±1%, B = ±0.5%, C = ±2%,)
- Y** = Year Code
- M** = Month Code  
(A=Jan, B=Feb, C=Mar, D=Apl, E=May, F=Jun, G=Jul, H=Aug, I=Sep, J=Oct, K=Nov, L=Dec)
- L** = Lot Code

EEPW 电子产品世界  
.com.cn

### Notice

Specifications of the products displayed herein are subject to change without notice. TSC or anyone on its behalf, assumes no responsibility or liability for any errors or inaccuracies.

Information contained herein is intended to provide a product description only. No license, express or implied, to any intellectual property rights is granted by this document. Except as provided in TSC's terms and conditions of sale for such products, TSC assumes no liability whatsoever, and disclaims any express or implied warranty, relating to sale and/or use of TSC products including liability or warranties relating to fitness for a particular purpose, merchantability, or infringement of any patent, copyright, or other intellectual property right.

The products shown herein are not designed for use in medical, life-saving, or life-sustaining applications. Customers using or selling these products for use in such applications do so at their own risk and agree to fully indemnify TSC for any damages resulting from such improper use or sale.