



This paper describes STMicroelectronics ADSL analog line interface solutions.

After a short overview of the ADSL application environment, this article focuses on the implementation of line drivers. Magnetic circuits such as hybrid or line transformer circuits will not be described in detail.

The ADSL concept

Asymmetric Digital Subscriber Line (ADSL) is a modem technology, which converts existing twisted-pair telephone lines into access paths for multimedia and high speed data communications.

An ADSL modem is connected to a twisted-pair telephone line, creating three information channels: a high-speed downstream channel (up to 1.1MHz and 2.2MHz for ADSL2+) depending on the implementation of the ADSL architecture, a medium-speed upstream channel (up to 135kHz or 230kHz) and a POTS (Plain Old Telephone Service), split off from the modem by filters.

Figure 1: Typical spectral representation of a DMT ADSL signal (subscriber side)

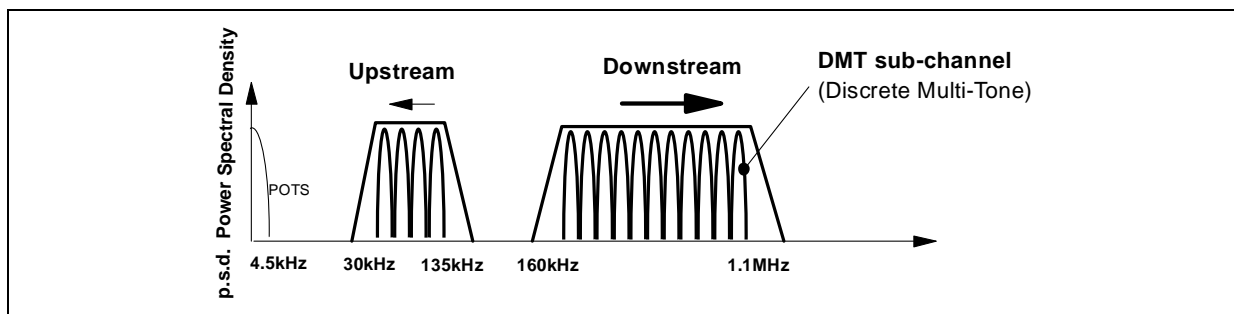

ADSL allows the wide-band access necessary to transmit media such as movies, television, remote CD-ROMs via LANs and the Internet into individual workplaces and homes.

The line interface - ADSL remote terminal (RT)

Figure 2 shows a typical analog line interface used for ADSL. The upstream and downstream signals are separated from the telephone line by using a hybrid circuit and a line transformer. On this note, emphasis will be placed on the emission path.

Figure 2: Typical ADSL Line Interface

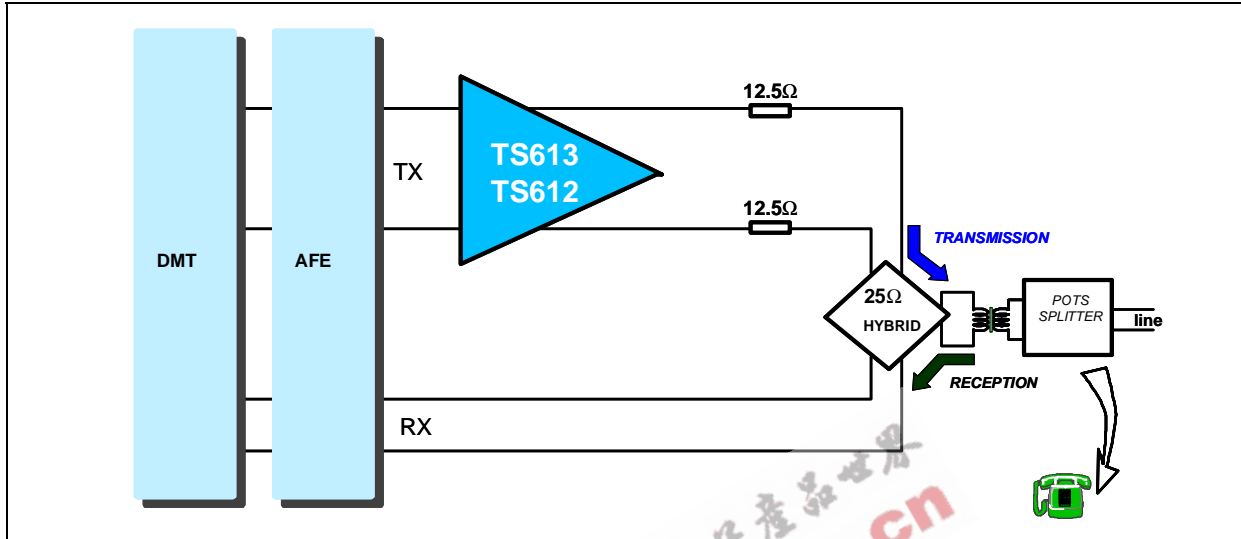

The emission path

The features of the TS613 and TS612 drivers are shown in Table 1 below.

Table 1: Features of drivers

		GBP (MHz)	BW Gain=4 (MHz)	SR (V/μs)	I _{out} typ. (mA)	Noise (nV/√Hz)	I _{cc} per op. (mA)	HD2/HD3 ¹ (dBc)	V _{out} diff. (V _{pp} min)	Packages
TS613	VFA	130	34	40	320	3	11	74/79	18	SO8 SO8 Exposed Pad
TS612	VFA	130	34	40	320	3	14	74/79	18	SO20 Batwing

1) Single ended 4V_{pp}/100kHz on 25Ω//15pF

In order to shrink the line interface size, the TS613 comes in the classic SO8 plastic package as well as the SO8 ExposedPAD plastic package, capable of dissipating 1.7W at room temperature. While this circuit does not feature a power-down function, it does have the advantage of featuring a standard pin-out.

Figure 3: Thermal considerations: power dissipation of the drivers vs. room temperature

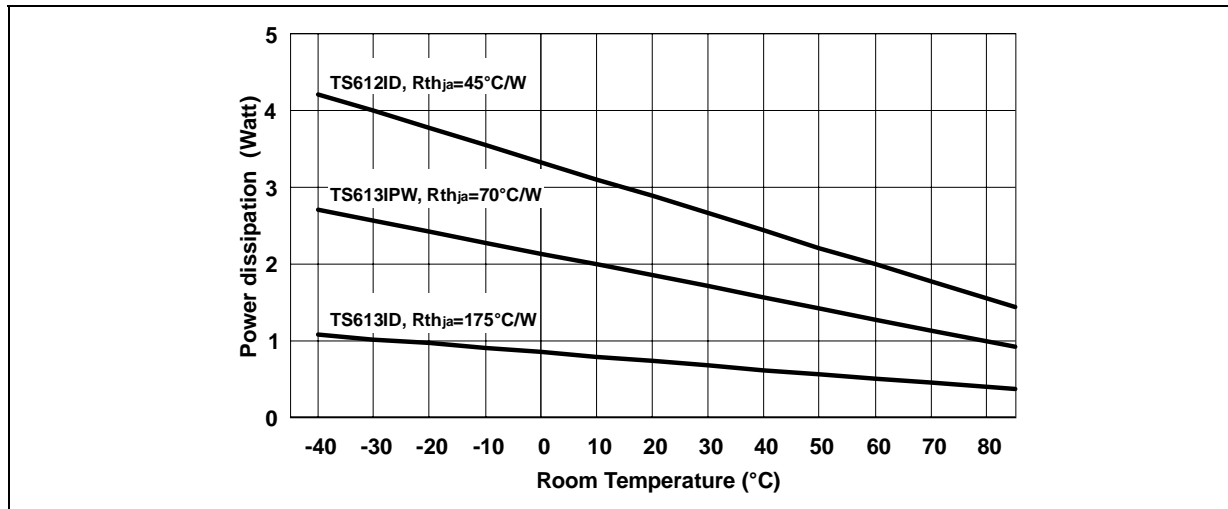

The TS612 comes in SO20 plastic batwing package which increases its power dissipation capability to 2.7W at room temperature. It features a power-down or stand-by function in order to minimize the consumption when the modem is not in communication.

Power Supply

Remote ADSL modem terminals must be designed to be easily connected to a PC. For such applications, the driver should use a +12V single power supply, which is available via standard PCI connectors. Note that the TS613 and TS612 can also be powered by a dual power supply at +/-6V.

Figure 4 shows a single +12V supply circuit with the TS613 as a remote terminal transmitter in differential mode. Note that one could also use the TS612 in exactly the same schema.

Figure 4: Implementation of the TS613 as a differential line driver with a +12V single supply

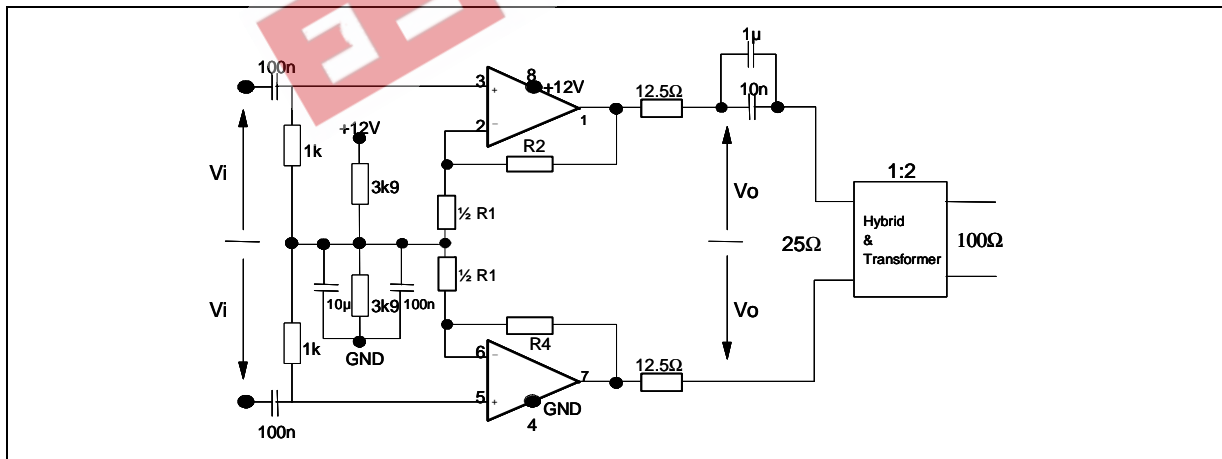

The driver is biased with a mid-supply (nominally +6V) in order to maintain the DC component of the signal at +6V. This allows a maximum dynamic range between 0 and +12 V. Several options are possible in order to provide this bias supply—such as for example, a virtual ground using an operational amplifier, or, the cheapest solution, a two-resistor divider. A high resistance value is required to limit the current consumption. On the other hand, the current must be high enough to bias the inverting input of the driver. If we consider the positive input's bias current (15µA max) as 1% of the current through the resistance divider (1.5mA), two 3.9kΩ resistors are sufficient to keep a stable mid-supply .

The input provides two high-pass filters with a break frequency of about 1.6kHz which is necessary to remove the DC component of the input signal. To avoid DC current flowing into the primary side of the transformer, an output capacitor is used. The $1\mu\text{F}$ capacitance provides a path for low frequencies, the 10nF capacitance provides a path for high end of the spectrum.

Filtering

As the hybrid circuit cannot perfectly separate the upstream signal and the downstream signal, any distortion from the upstream signal could affect the downstream signal. For the upstream path, a low-pass filter becomes absolutely necessary in order to cut off the higher frequencies from the DAC analog output and the driver distortions. In this simple non-inverting amplification configuration, it is easy to implement a Sallen-Key low-pass filter by using the TS613 or TS612.

Figure 5: Transmission path filtering

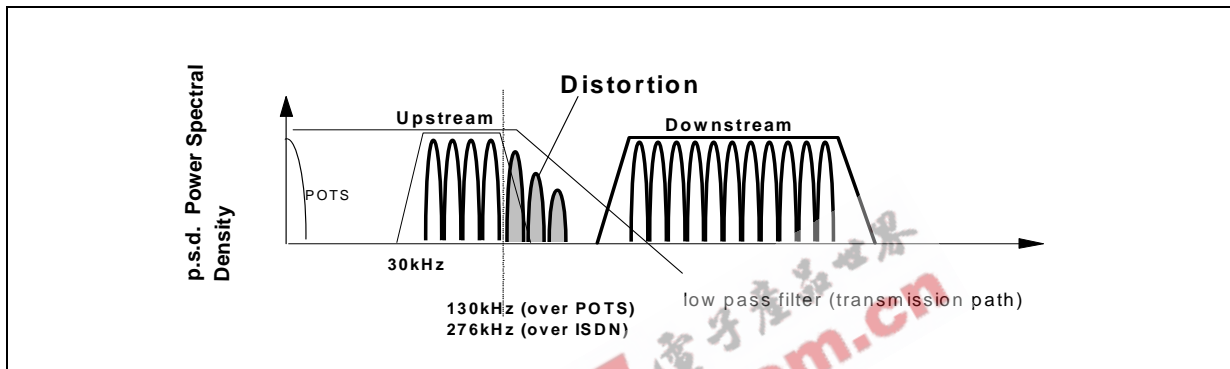

A first solution is to use a LC cell before the driver to provide the low-pass filtering. Nevertheless, as shown in [Figure 6](#), using 2nd order active filtering is a good solution especially as regards cost and space-saving considerations.

Figure 6: TS613 line driver with 2nd order active filtering

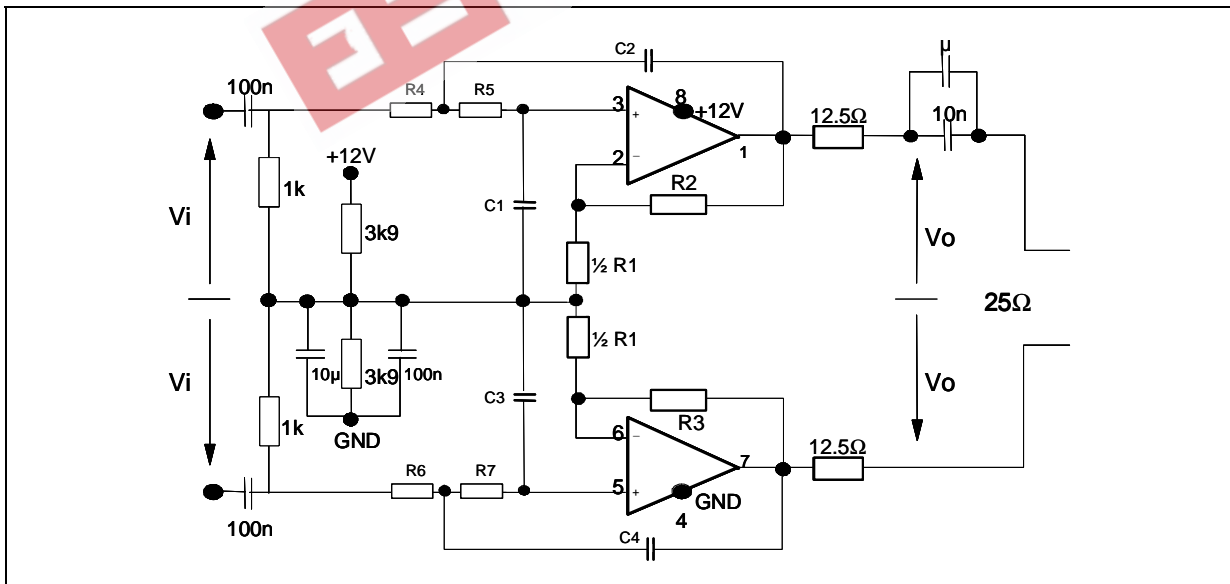

In the configuration shown in [Figure 6](#), we assume $R4=R6$, $R5=R7$, $C1=C3$ and $C2=C4$.

The resistances R1, R2 and R3 allow us to calculate the gain of the structure as follows:

$$\text{Gain} = 1 + \frac{2R2}{R1} = 1 + \frac{2R3}{R1}$$

The damping factor can be derived from these resistances and the capacitances C1, C2, C3 and C4:

$$\zeta = \frac{2C1 - \alpha C2}{2\sqrt{C1C2}} = \frac{2C3 - \alpha C4}{2\sqrt{C3C4}}$$

with:

$$\alpha = \frac{2R2}{R1} = \frac{2R3}{R1}$$

The higher the gain, the more sensitive the damping factor is. When the gain is higher than 1 it is preferable to use very stable resistance and capacitance values.

The value of the gain does not affect the cut-off frequency, f_c , which is derived as follows:

$$f_c = \frac{1}{2\pi\sqrt{R4R5C1C2}} = \frac{1}{2\pi\sqrt{R6R7C3C4}}$$

Moreover this expression shows that it is possible to shift the cut-off frequency by simply changing the values of the resistances R4, R5 or R6, R7 — with neither a change of capacitance nor of the damping factor.

The following table shows a calculations of components for a cut-off frequency around 130kHz for the ADSL over POTS and 270kHz for the ADSL over ISDN. The final, accurate settings are made by compromising between the attenuation of the highest frequencies of the upstream signal and the impact of the distortion on the downstream signal. This is best done directly in the application. Nevertheless we can start with the following initial values:

R1 (Ω)	R2 R3 (Ω)	R4 R6 (Ω)	R5 R7 (Ω)	C1 C3 (nF)	C2 C4 (nF)	Gain (dB)	f_c (kHz)	ζ
180	536	261	261	10	2.2	16.8	130	0.73
180	536	127	127	10	2.2	16.8	270	0.73

Transformation ratio

In differential mode, the TS613 and TS612 are able to deliver a typical amplitude signal of 18V peak to peak.

The dynamic line impedance is 100 Ω . The typical value of the amplitude signal required on the line is up to 12.4V peak to peak. By using a 1:2 transformer ratio the reflected impedance back to the primary will be a quarter (25 Ω) and therefore the amplitude of the signal required with this impedance will be halved (6.2 V peak to peak). Assuming a 25 Ω series resistance (12.5 Ω for both outputs) is necessary for impedance matching, the output signal amplitude required is 12.4V peak to peak. This value is acceptable for both TS613 and TS612. In this case, the load impedance is 25 Ω for each driver in single ended.

Increasing the line level by using an active impedance matching

With passive matching, the output signal amplitude of the driver must be twice the amplitude on the load. To go beyond this limitation an active matching impedance can be used. With this technique it is possible to maintain good impedance matching with an amplitude on the load higher than half of the output driver amplitude. This concept is shown in *Figure 7* for a differential line.

Figure 7: TS613 as a differential line driver with an active impedance matching

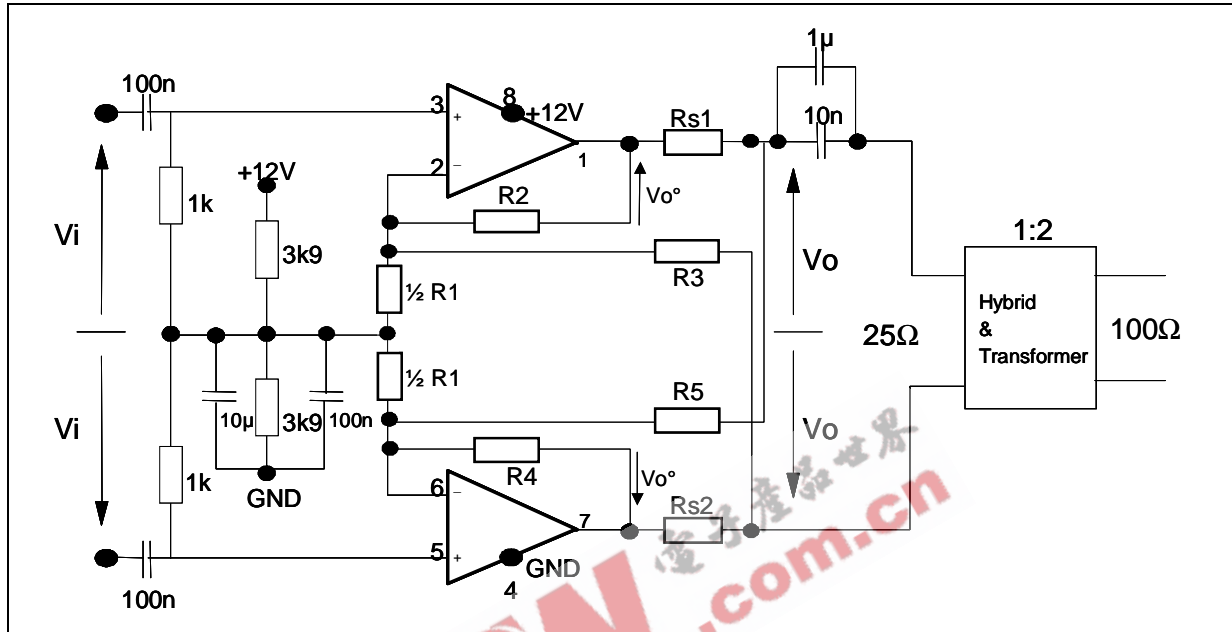

Component calculation

Let us consider the equivalent circuit for a single-ended configuration, as shown in *Figure 8*.

Figure 8: Single ended equivalent circuit

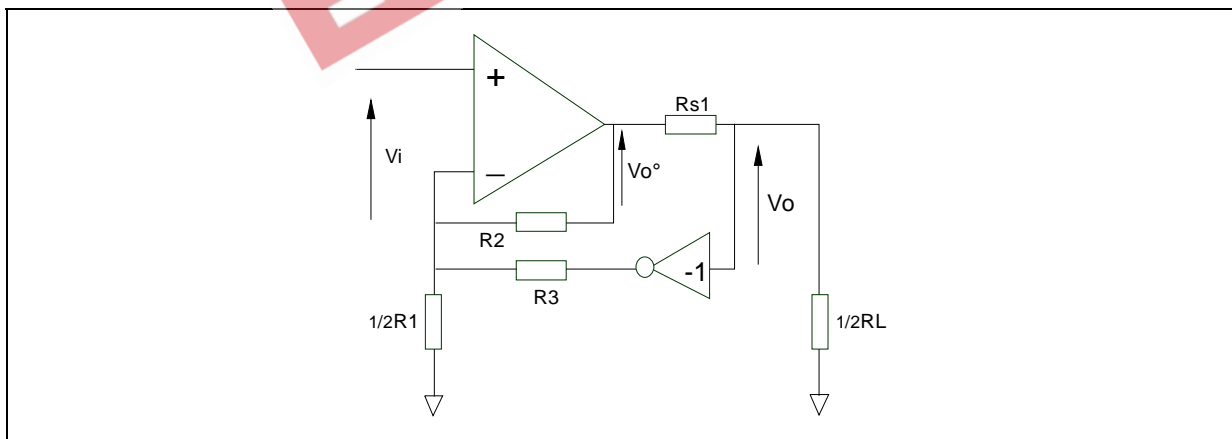

For unloaded system, we can assume that currents through R1, R2 and R3 are respectively:

$$\frac{2 Vi}{R1}, \frac{(Vi - Vo^o)}{R2} \text{ and } \frac{(Vi + Vo)}{R3}$$

As V_o° equals V_o without loading, the gain in this case becomes:

$$G = \frac{V_o(\text{no load})}{V_i} = \frac{1 + \frac{2R_2}{R_1} + \frac{R_2}{R_3}}{1 - \frac{R_2}{R_3}}$$

The gain for the loaded system will be:

Equation 1

$$G_L = \frac{V_o(\text{with load})}{V_i} = \frac{1}{2} \frac{1 + \frac{2R_2}{R_1} + \frac{R_2}{R_3}}{1 - \frac{R_2}{R_3}}$$

As shown in [Figure 9](#), this system is an ideal generator, with a synthesized impedance equal to the internal impedance of the system. Therefore, the output voltage becomes:

Equation 2

$$V_o = (V_i G) - (R_o I_{out})$$

with R_o the synthesized impedance and I_{out} the output current. On the other hand V_o can be expressed as:

Equation 3

$$V_o = \frac{V_i \left(1 + \frac{2R_2}{R_1} + \frac{R_2}{R_3}\right) \frac{R_{s1} I_{out}}{1 - \frac{R_2}{R_3}}}{1 - \frac{R_2}{R_3}}$$

Figure 9: Equivalent schematic, where R_o is the synthesized impedance

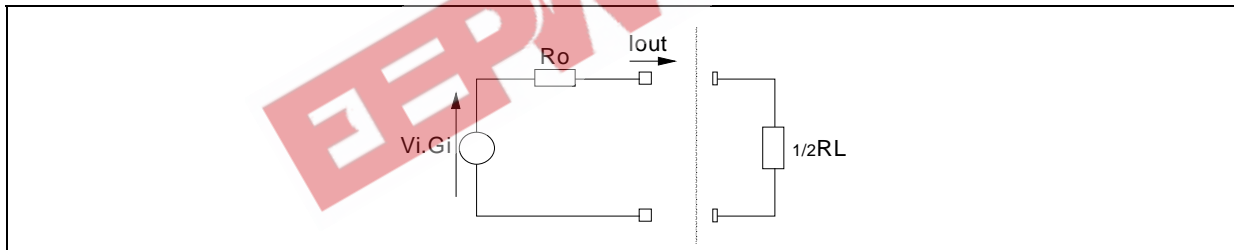

By identifying of both [Equation 2](#) and [Equation 3](#), the synthesized impedance is, with $R_{s1}=R_{s2}=R_s$:

Equation 4

$$R_o = \frac{R_s}{1 - \frac{R_2}{R_3}}$$

Unlike the level of V_o° required for passive impedance, V_o° will be smaller than $2V_o$ in this case. Let us write $V_o^\circ = kV_o$ with k the matching factor varying between 1 and 2. Assuming that the current through R_3 is negligible, the resistance divider becomes:

$$R_o = \frac{kV_o R_L}{R_L + 2R_{s1}}$$

After choosing the k factor, R_s will equal to $1/2RL(k-1)$.

A good impedance matching assumes:

$$\text{Equation 5} \quad R_o = \frac{1}{2}RL$$

From [Equation 3](#) and [Equation 5](#) we derive:

$$\text{Equation 6} \quad \frac{R_2}{R_3} = 1 - \frac{2R_s}{RL}$$

By fixing an arbitrary value for R2 in [Equation 6](#), we arrive at:

$$R_3 = \frac{R_2}{1 - \frac{2R_s}{RL}}$$

Finally, the values of R2 and R3 allow us to extract R1 from [Equation 1](#) so that:

$$\text{Equation 7} \quad R_1 = \frac{2R_2}{2\left(1 - \frac{R_2}{R_3}\right)G_L - 1 - \frac{R_2}{R_3}}$$

with G_L the required gain.

G_L (gain for the loaded system)	G_L is fixed for the application requirements $G_L = V_o/V_i = 0.5(1 + 2R_2/R_1 + R_2/R_3)/(1 - R_2/R_3)$
R1	$2R_2/[2(1 - R_2/R_3)G_L - 1 - R_2/R_3]$
R2 (=R4)	Arbitrarily fixed
R3 (=R5)	$R_2/(1 - R_s/0.5RL)$
R_s	$0.5RL(k-1)$

Capabilities

The table below shows the calculated components for different values of k for a differential load of 25Ω. In all cases, R2=1000Ω and the gain=16dB. The last column displays the maximum amplitude level on the line regarding the TS613 maximum output capabilities (18Vp-p diff.) and a 1:2 line transformer ratio.

Active matching				TS613 Output Level to get 12.4Vpp on the line with a turn ratio of 2. (Vp-p diff)	Maximum Line Level (Vp-p diff)
k	R1 (Ω)	R3 (Ω)	R _s (Ω)		
1.3	953	1400	3.75 (3.9//100)	8.06	27.5
1.4	590	1620	5 (10//10)	8.68	25.7
1.5	422	2000	6.36 (6.8//100)	9.35	25.3
1.6	316	2490	7.57 (8.2//100)	9.95	23.7
1.7	261	3300	8.71 (10//68)	10.52	22.3
Passive matching				12.4	18

Measurement of power consumption in application

Conditions:

- Passive impedance matching
- Transformer turns ratio: 2
- Maximum level required on the line: 12.4Vpp
- Maximum output level of the driver: 12.4Vpp

- Crest factor: 5.3 (Vp/Vrms)
- Power Supply: 12V

Power consumption of the driver during emission on 900 and 4550 meter twisted pair telephone lines:

- TS613: **360mW**
- TS612: **450mW**

EEPW 电子产品世界
.com.cn

Information furnished is believed to be accurate and reliable. However, STMicroelectronics assumes no responsibility for the consequences of use of such information nor for any infringement of patents or other rights of third parties which may result from its use. No license is granted by implication or otherwise under any patent or patent rights of STMicroelectronics. Specifications mentioned in this publication are subject to change without notice. This publication supersedes and replaces all information previously supplied. STMicroelectronics products are not authorized for use as critical components in life support devices or systems without express written approval of STMicroelectronics.

The ST logo is a registered trademark of STMicroelectronics
All other names are the property of their respective owners

© 2004 STMicroelectronics - All rights reserved

STMicroelectronics group of companies

Australia - Belgium - Brazil - Canada - China - Czech Republic - Finland - France - Germany - Hong Kong - India - Israel - Italy - Japan - Malaysia - Malta - Morocco - Singapore - Spain - Sweden - Switzerland - United Kingdom - United States of America

www.st.com