



TS1118

500mA Low Dropout Positive Voltage Regulator

TO-92



SOT-223



SOT-89



Pin assignment:
 1. Ground / Adj
 2. Output
 3. Input

Low Dropout Voltage 1.3V max.

General Description

The TS1118 Series are high performance positive voltage regulators are designed for use in applications requiring low dropout performance at full rated current, Additionally, the TS1118 Series provides excellent regulation over variations due to changes in line, load and temperature. Outstanding features include low dropout performance at rated current, fast transient response, internal current limiting and thermal shutdown protection of the output device. The TS1118 Series are three terminal regulators with fixed and adjustable voltage options available in popular packages.

This series is offered in 3-pin TO-263, TO-220, TO-252 and SOT-223 package.

Features

- ◇ Low dropout performance 1.3V max.
- ◇ Full current rating over line and temperature.
- ◇ Fast transient response
- ◇ ±2% Total output regulation over line, load and temperature
- ◇ Adjust pin current max 90 μ A over temperature
- ◇ Line regulation typical 0.015%.
- ◇ Load regulation typical 0.05%.
- ◇ Fixed/adjustable output voltage
- ◇ TO-92, SOT-89 and SOT-223 package

Block Diagram

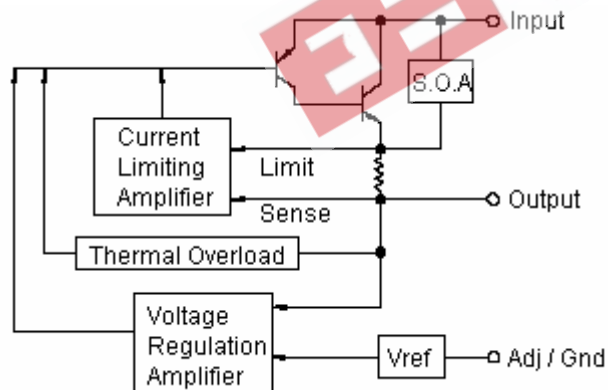

Ordering Information

Part No.	Operating Temp. (Ambient)	Package
TS1118CT-xx	-20 ~ +85 °C	TO-220
TS1118CY-xx		SOT-89
TS1118CW-xx		SOT-223

Note: Where xx denotes voltage option, available are 5.0V, 3.3V, 2.5V and 1.8V. Leave blank for adjustable version. Contact factory for additional voltage options.

Absolute Maximum Rating

Input Supply Voltage	V _{in}	12	V
Operation Input Supply Voltage	V _{in (operate)}	7	V
Power Dissipation	P _D	Internally Limited	W
Operating Junction Temperature Range	T _J	-25 ~ +150	°C
Storage Temperature Range	T _{STG}	-65 ~ +150	°C
Lead Soldering Temperature (260 °C) TO-92 / SOT-89 / SOT-223 Package		5	S



Electrical Characteristics					
Ta = 25 °C, unless otherwise specified. Adjustable version test with Vout = 2.5V.					
Parameter	Conditions	Min	Typ	Max	Unit
Output Voltage	Vout+1.5V ≤ Vin ≤ 7V, Io=10mA	0.990 Vo	5.0 / 3.3	1.010 Vo	V
	Vout+1.5V ≤ Vin ≤ 7V, Io=800mA	0.980 Vo	2.5 / 1.8	1.020 Vo	V
Reference Voltage	(Vin-out) = 1.5V, Io=10mA	0.990 Vo	1.25	1.010 Vo	V
	(Vin-out) = 1.5V, Io=800mA	0.980 Vo		1.020 Vo	V
Input Supply Voltage		--	--	7	V
Line Regulation	Vout+1.5V ≤ Vin ≤ 7V, Io=10mA	--	0.015	0.2	%
Load Regulation (note 1,2)	Vin=Vout+1.5V, 10mA ≤ Io ≤ 800mA	--	0.05	1.0	%
					%
Dropout Voltage	Io=1A, ΔVout=1%Vout	--	1.3	1.4	V
Minimum Load Current	Vin=5V	--	8	10	mA
Adjustable Pin Current		--	90	--	uA
Current Limit	Vin - Vout=3V	1.1	--	--	A
Temperature Stability	Io=10mA	--	0.5	--	%
Ripple Rejection	F = 120Hz, Io=1A Cout=25uF, Vin=Vout + 3V	--	60	70	dB

Thermal Performance			
Condition	Package type	Typ	Unit
Thermal Resistance Junction to Ambient	TO-92	160	°C/W
	SOT-89	180	
	SOT-223	110	

Note 1: See thermal regulation specification for changes in output voltage due to heating effects. Line and load regulation are measured at a constant junction temperature by low duty cycle pulse testing. Load regulation is measured at the output lead = 1/18" from the package.

Note 2: Line and load regulation are guaranteed up to the maximum power dissipation of 15W. Power dissipation is determined by the input / output voltage difference and the output current. Guaranteed maximum power dissipation will not be available over the full input / output voltage range.

Note 3: Quiescent current is defined as the minimum output current required to maintain the regulation.

Typical Application Circuit

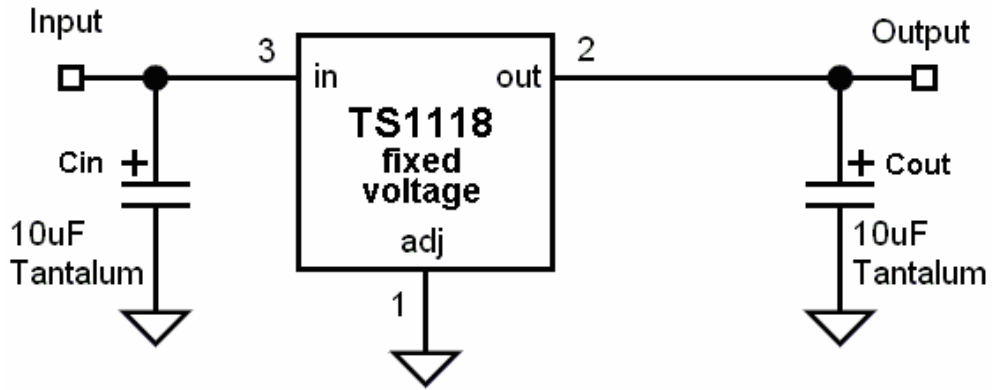

Fixed output voltage version

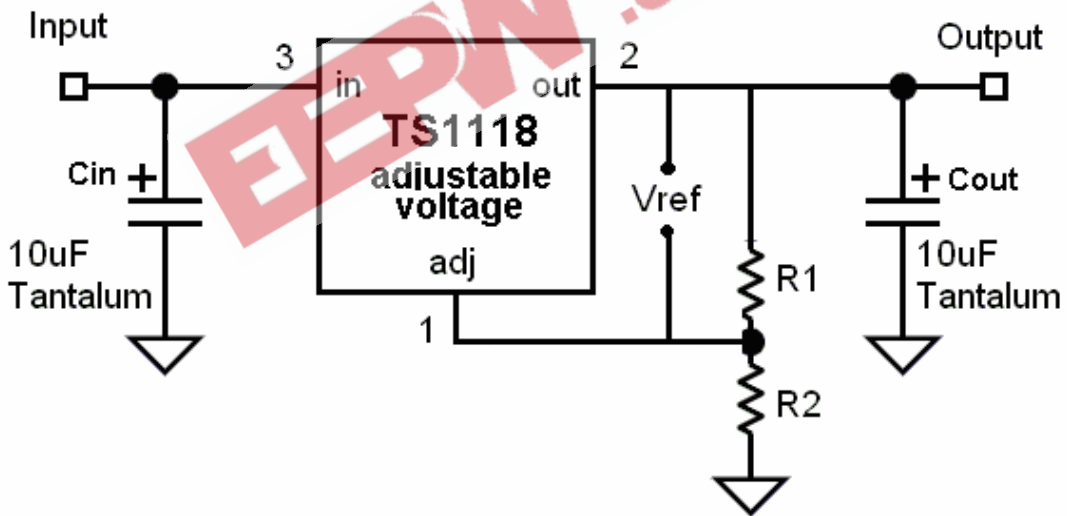

$$V_{out} = V_{ref} * (1 + R2 / R1)$$

* Cin is requested if regulator is located

Far from power supply filter

** Design Cout as close to Vout pin as possible

Adjustable output voltage version

Electrical Characteristics Curve

Figure 1: load transient response

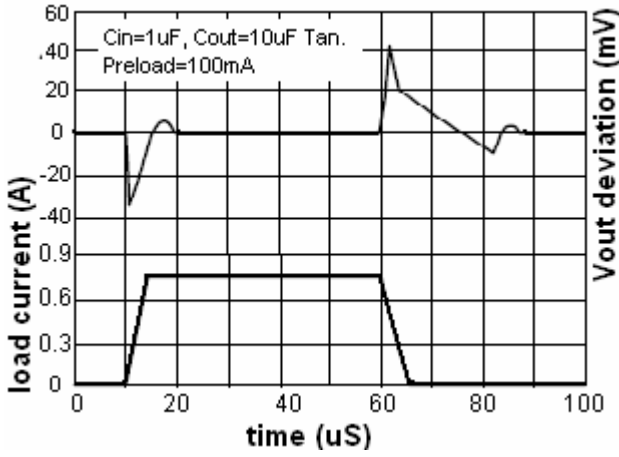

Figure 2: load regulation v.s. temp.

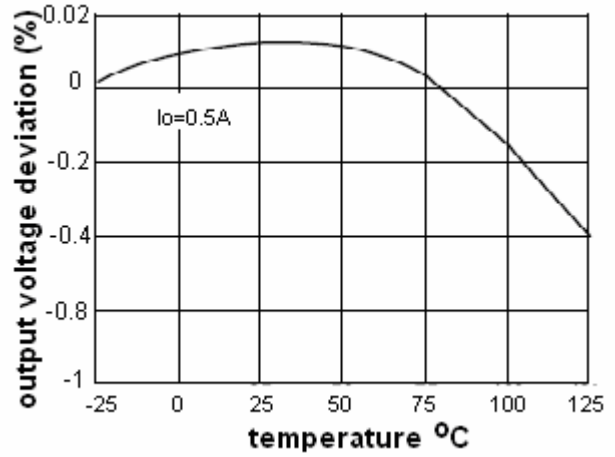

Figure 3: output change v.s. temp.

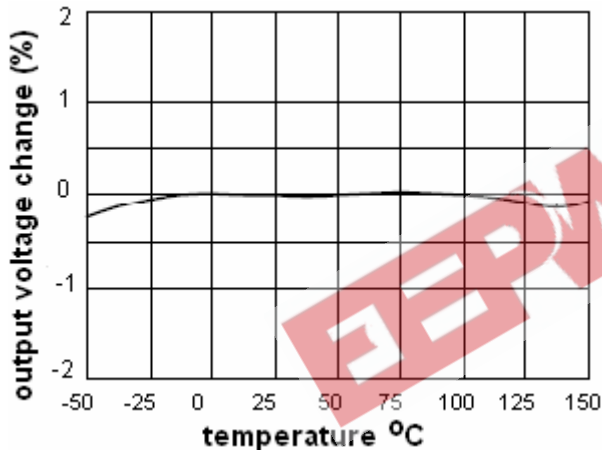

Figure 4: line regulation

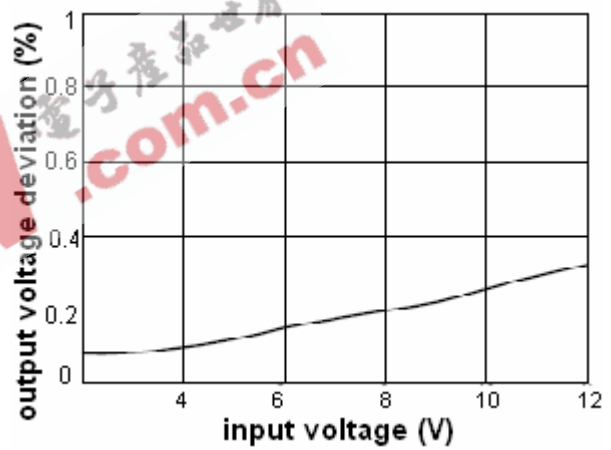
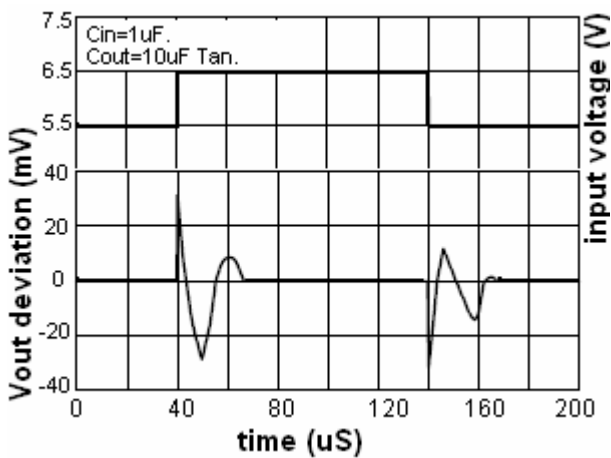
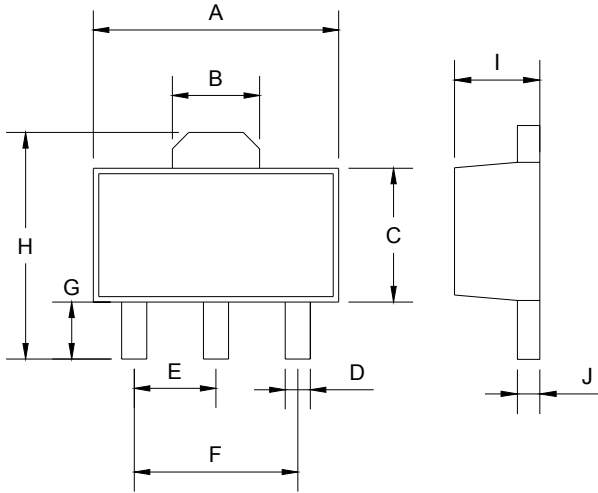

Figure 5: line transient response



SOT-89 Mechanical Drawing



SOT-89 DIMENSION				
DIM	MILLIMETERS		INCHES	
	MIN	MAX	MIN	MAX
A	4.40	4.60	0.173	0.181
B	1.50	1.7	0.059	0.070
C	2.30	2.60	0.090	0.102
D	0.40	0.52	0.016	0.020
E	1.50	1.50	0.059	0.059
F	3.00	3.00	0.118	0.118
G	0.89	1.20	0.035	0.047
H	4.05	4.25	0.159	0.167
I	1.4	1.6	0.055	0.068
J	0.35	0.44	0.014	0.017

TO-92 Mechanical Drawing

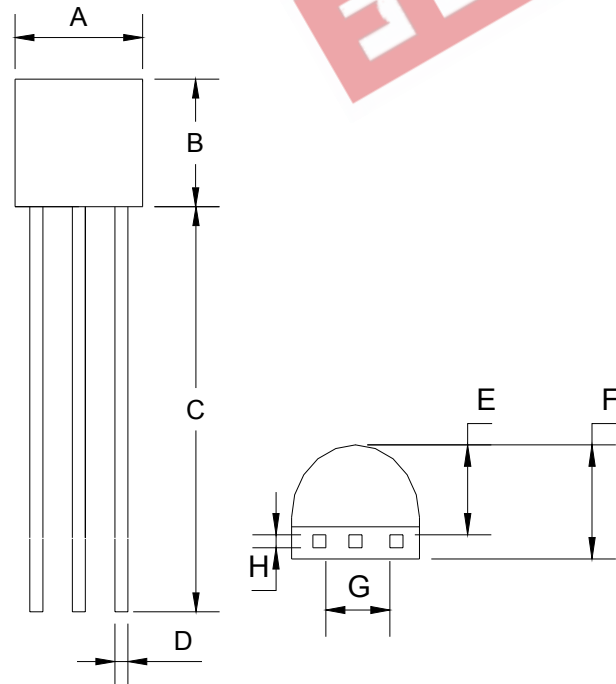

TO-92 DIMENSION				
DIM	MILLIMETERS		INCHES	
	MIN	MAX	MIN	MAX
A	4.30	4.70	0.169	0.185
B	4.30	4.70	0.169	0.185
C	14.30(typ)		0.563(typ)	
D	0.43	0.49	0.017	0.019
E	2.19	2.81	0.086	0.111
F	3.30	3.70	0.130	0.146
G	2.42	2.66	0.095	0.105
H	0.37	0.43	0.015	0.017

SOT-223 Mechanical Drawing

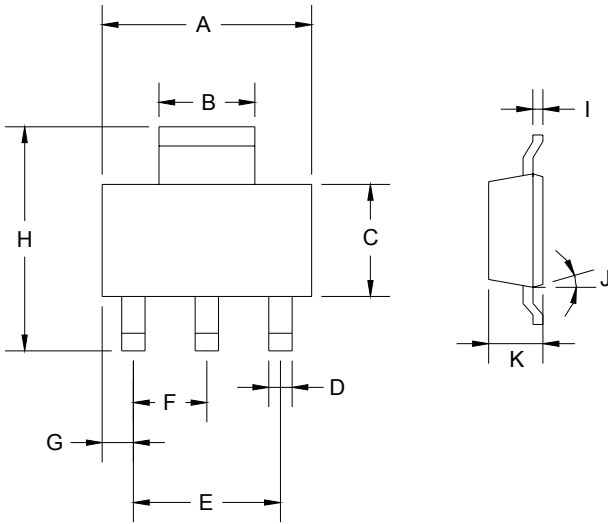

SOT-223 DIMENSION				
DIM	MILLIMETERS		INCHES	
	MIN	MAX	MIN	MAX
A	6.350	6.850	0.250	0.270
B	2.900	3.100	0.114	0.122
C	3.450	3.750	0.136	0.148
D	0.595	0.635	0.023	0.025
E	4.550	4.650	0.179	0.183
F	2.250	2.350	0.088	0.093
G	0.835	1.035	0.032	0.041
H	6.700	7.300	0.263	0.287
I	0.250	0.355	0.010	0.014
J	10°	16°	10°	16°
K	1.550	1.800	0.061	0.071

EEPW.com.cn 电子产业网