



TS9002

300mA CMOS LDO with Enable & Power Good

SOT-25



Pin assignment

- 1. Input
- 2. Ground
- 3. Enable
- 4. Power Good
- 5. Output

Low Drop Out Voltage 0.4V
Enable Shutdown
Power Good

General Description

The TS9002 series is a positive voltage linear regulator developed utilizing CMOS technology featured low quiescent current (30uA typ.), low dropout voltage, and high output voltage accuracy, making them ideal for battery applications. The Chip Enable (CE) includes a CMOS or TTL compatible input allows the output to be turned off to prolong battery life. The TS9002 series is included a precision voltage reference, error correction circuit, a current limited output driver, over temperature shutdown, and a "Power Good" detector, which pulls low when the output is out of regulation. This series are offered in 5-pin SOT-25 package.

Features

- ✧ Dropout voltage typically 0.4V@Io=300mA (Vo>2.5V)
- ✧ Low power consumption
- ✧ Output voltage +/-2%, +/-3% (1.2V)
- ✧ Internal current limit and thermal shutdown
- ✧ Short circuit current fold-back
- ✧ Power saving shutdown mode
- ✧ Power good output function

Ordering Information

Part No.	Operating Temp. (Ambient)	Package
TS9002xCX5	-40 ~ +85 °C	SOT-25

Note: Where **x** denotes voltage option, available are
 1=1.2V
 A=1.5V
 K=2.5V,
 S=3.3V,
 Contact factory for additional voltage options.

Applications

- ✧ Palmtops
- ✧ Video recorders
- ✧ Battery powered equipment
- ✧ PC peripherals
- ✧ High-efficiency linear power supplies
- ✧ Digital signal camera

Typical Application Circuit

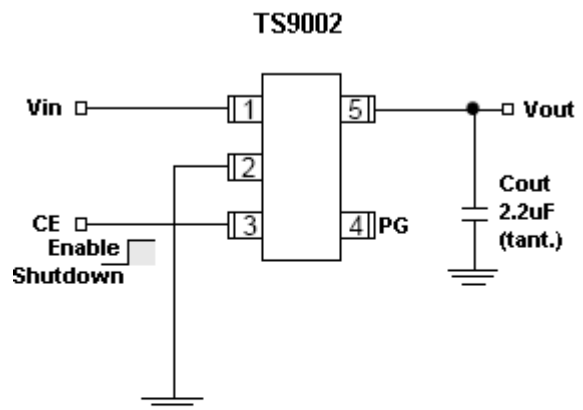

CE (pin 3) may be connected directly to Vin (pin 1)
 PG (pin 4) can occur under the following conditions:
 1. input voltage too low.
 2. during over-temperature
 3. during over-current.
 4. if output is pulled up.
 (note: PG pin is an open-drain output.)

Block Diagram

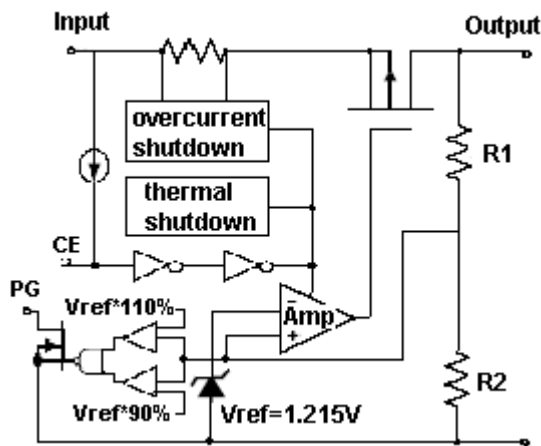



Absolute Maximum Rating			
Input Supply Voltage	V _{in}	+7	V
Enable Input Voltage	V _{ce}	Gnd-0.3 ~ Vin+0.3	V
Output Current	I _o	P _d / (V _{in} - V _{out})	
Power Dissipation	P _D	380	mW
Thermal Resistance	θ _{ja}	260	°C/W
Operating Junction Temperature Range	T _j	-40 ~ +125	°C
Storage Temperature Range	T _{STG}	-65 ~ +150	°C
Lead Soldering Temperature (260 °C)		10	S

Caution: Stress above the listed absolute rating may cause permanent damage to the device.

Electrical Characteristics

(T_a = 25 °C, I_o=0.1mA, C_{out}=2.2uF, V_{ce}≥2V; V_{in} >2.7V & I_o<150mA for 1.2V output type, unless otherwise specified.)

Parameter	Conditions		Min	Typ	Max	Unit
Output Voltage	V _{in} =V _o + 1V	V _{out} > 1.5V	0.985 V _o		1.015 V _o	V
	V _{in} =2.7V	V _{out} <1.5V	0.970 V _o		1.030 V _o	
V _{out} Temperature Coefficient			--	30	--	ppm/°C
Maximum Output Current	V _{in} =V _o + 1V	V _{out} > 1.5V	300	--	--	mA
	V _{in} =2.7V	V _{out} <1.5V	150	--	--	
Line Regulation	V _o +1V ≤ V _{in} ≤ V _o +2V		--	--	0.3	%
Load Regulation	V _{in} =V _o +1V, 1mA≤I _L ≤300mA		--	0.2	1.0	%
Load Regulation (1.2V output)	V _{in} =2.7V, 1mA≤I _L ≤150mA		--	1	4.0	
Dropout Voltage	I _o =300mA, V _{out} =V _o - 2%	V _{out} ≥2.0V	--	300	400	mV
		V _{out} <2.0V	--	800	1300	
Quiescent Current	V _{in} ≤0.4V (shutdown)		--	1	2	uA
Quiescent Current	V _{out} ≥0.4V, I _o =0mA	V _{out} > 1.5V	--	30	50	uA
		V _{out} <1.5V	--	50	80	
Output Current Limit	V _{out} =0V	V _{out} > 1.5V	--	450	--	mA
		V _{out} <1.5V	--	350	--	
Power Supply Rejection Ratio	I _o =100mA,	At f=1kHz,	--	50	--	dB
		At f=10kHz,	--	20	--	
Output Noise	I _o =10mA, f=10Hz to 100kHz,		--	30	--	uVrms
Enable Input						
Enable Input Logic-Low Voltage	Regulation shutdown		--	--	0.4	V
Enable Input Logic-High Voltage	Regulation enable		2.0	--	--	V
Enable Input Current	V _{IL} ≤0.4V		--	--	0.5	uA
	V _{IL} ≥2.0V		--	--	0.1	



Electrical Characteristics (continued)						
Power Good						
Output under voltage	$1.5V \leq V_{O(NOM)}$	--	--	85	%	
	$V_{O(NOM)} < 1.5V$	--	--	75	$V_{O(NOM)}$	
Output over voltage	$2.5V \leq V_{O(NOM)} \leq 5.0V$	115	--	--	%	
	$1.2V \leq V_{O(NOM)} \leq 2.5V$	125	--	--	$V_{O(NOM)}$	
PG leakage current	$V_{PG} = 7V$	--	--	1	μA	
PG voltage rating	V_o in regulation	--	--	7	V	
PG voltage low	$I_{sink} = 0.4mA$	$V_o > 1.5V$	--	--	0.4	V
	$I_{sink} = 0.1mA$	$V_o < 1.5V$	--	--	0.1	
Detail Description						
Description						
<p>The TS9002 series of CMOS regulators contain a P-MOS pass transistor, voltage reference, error amplifier, over current protection, thermal shutdown and power good function.</p> <p>The TS9002 series switches from voltage mode to current mode when the load exceeds the rated output current. This prevents over stress. The TS9002 also incorporates current fold-back to reduce power dissipation when the output is short circuit. This feature becomes active when the output drops below 0.8V, and reduces the current flow by 65%. Full current is restored when the voltage exceeds 0.8V.</p> <p>The internal P-channel pass transistor receives data from the error amplifier, over current shutdown, short output protection and thermal protection circuits. During normal operation, the error amplifier compares the output voltage to a precision reference. Over current and thermal shutdown circuits become active when the junction temperature exceeds 150 °C, or the current exceeds 300mA. During thermal shutdown, the output voltage remains low. Normal operation is restored when the junction temperature drops below 120 °C.</p>						
Enable						
<p>The Chip Enable pin normally floats high. When actively, pulled low, the PMOS pass transistor shut off, and all internal circuits are powered down. In this state, the quiescent current is less than 1μA. This pin behaves much like an electronic switch.</p>						
External Capacitor						
<p>The TS9002series is stable with an output capacitor to ground of 2.2μF or greater. It can keep stable even with higher or poor ESR capacitors.</p> <p>A second capacitor is recommended between the input and ground to stabilize V_{in}. The input capacitor should be larger than 0.1μF to have a beneficial effect.</p> <p>All capacitors should be placed in close proximity to the pins. A “quiet” ground termination is desirable.</p>						
Power Good						
<p>The TS9002 includes the Power Good feature. When the output is not within $\pm 15\%$ of the specified voltage, it pulls low. This can occur on other condition – input voltage too low, during over-temperature, during over-current and output is pulled up.</p>						

Typical Electrical Characteristics

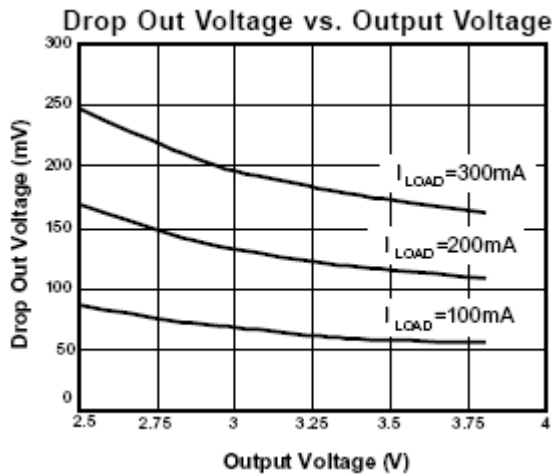
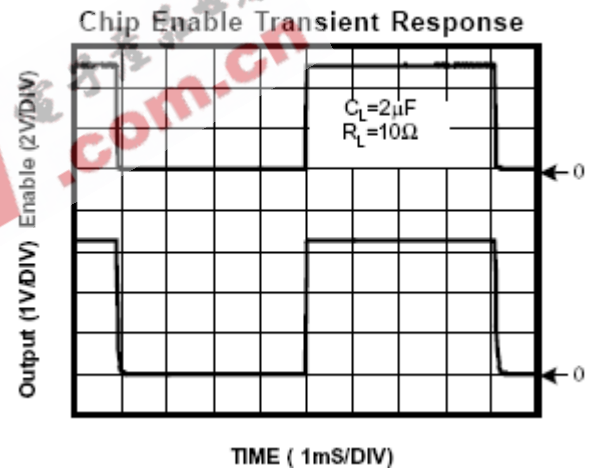
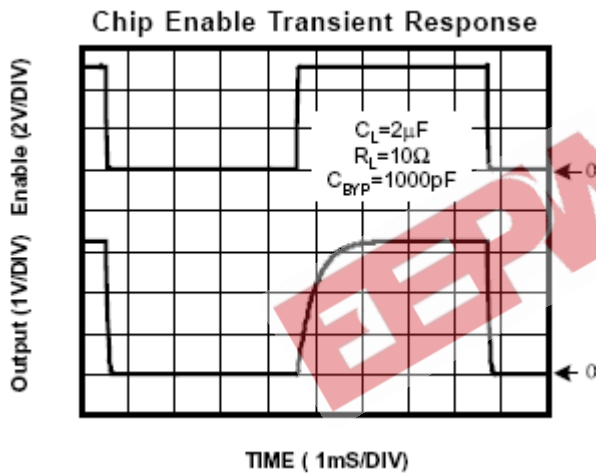
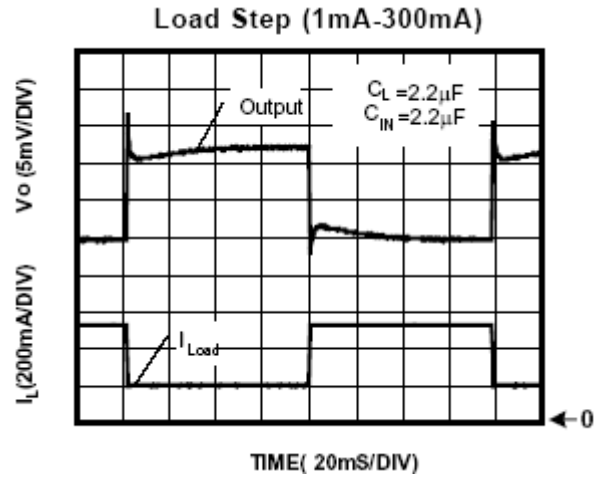
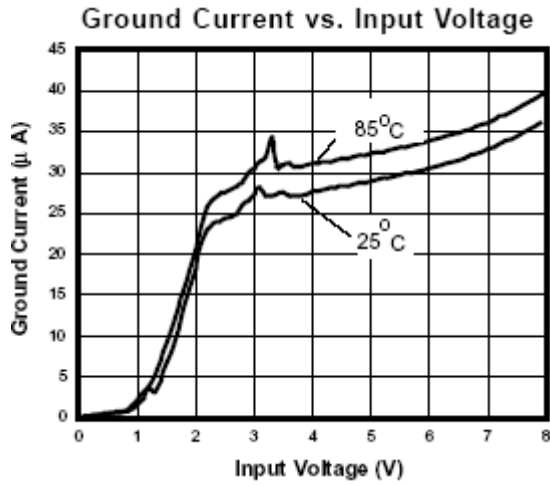

SOT-25 Mechanical Drawing

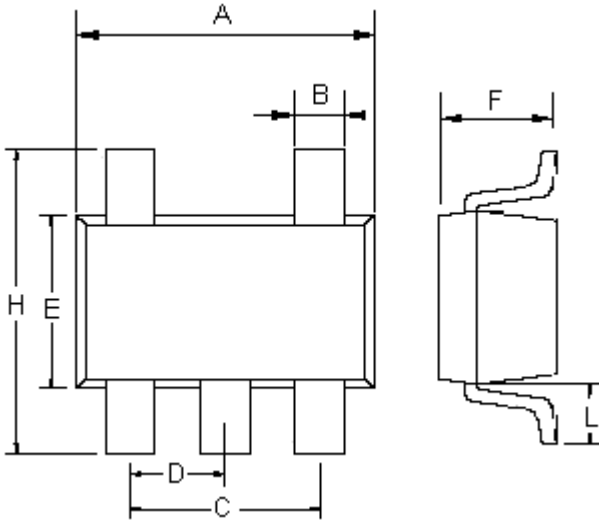

SOT-25 DIMENSION				
DIM	MILLIMETERS		INCHES	
	MIN	MAX	MIN	MAX
A	2.70	3.00	0.106	0.118
B	0.25	0.50	0.010	0.020
C	1.90(typ)		0.075(typ)	
D	0.95(typ)		0.037(typ)	
E	1.50	1.70	0.059	0.067
F	1.05	1.35	0.041	0.053
H	2.60	3.00	0.102	0.118
L	0.60(typ)		0.024(typ)	

EEPW 电子产品世界
 .com.cn