

NEW

Radiometrix

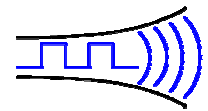

Hartcran House, 231 Kenton Lane, Harrow, HA3 8RP, England

Issue 3, 15 October 2007

Tel: +44 (0) 20 8909 9595, Fax: +44 (0) 20 8909 2233

TX2M/RX2M

UHF Narrow Band FM multi channel radio modules

UK Version: TX2M-458-5/RX2M-458-5 (100mW)

European version: TX2M-433-5/RX2M-433-5 (10mW)

The TX2M transmitter and RX2M receiver modules offer a low power, reliable data link in an industry-standard pin out and footprint. This makes the TX2M/RX2M pair ideally suited to those low power applications where existing wideband modules have insufficient range, or where multi-channel operation is needed. Two versions are available, covering the 458.5-459.1MHz UK band (at 100mW) and the European 433.05-434.79MHz band.



RX2M-458-5

TX2I-458-5

Features

- 433MHz version conforms to EN 300 220-3 and EN 301 489-3 and 458MHz version to MPT 1329 (UK specs)
- Any custom band between 420MHz and 480MHz with 5MHz (AR0) frequency range
- High performance double superhet, 128 channel PLL synthesizer with TCXO
- Data rates up to 5 kbps for standard module
- Usable range over 1km
- Fully screened. Low profile
- Feature-rich interface (RSSI, automatic noise squelch, analogue and digital baseband)
- Incorporate a 1200baud dumb modem
- Re-programmable via RS232 interface
- Low power requirements

Applications

- Handheld terminals
- EPOS equipment, barcode scanners
- Data loggers
- Industrial telemetry and telecommand
- In-building environmental monitoring and control
- High-end security and fire alarms
- Vehicle data up/download

Technical Summary

- Size: 59 x 38 x 7mm
- Operating frequency: 458.5-459.1MHz or 433.05-434.79MHz
- 23 channels in 458MHz band (128 channels max.)
- Transmit power: +20dBm (100mW) nominal
- Supply range: 4.5V - 16V
- Current consumption: 100mA transmit, 13mA receive
- Data bit rate: 5kbps max. (standard module)
- Receiver sensitivity: -118dBm (for 12 dB SINAD)

TX2M-433 or TX2M-458

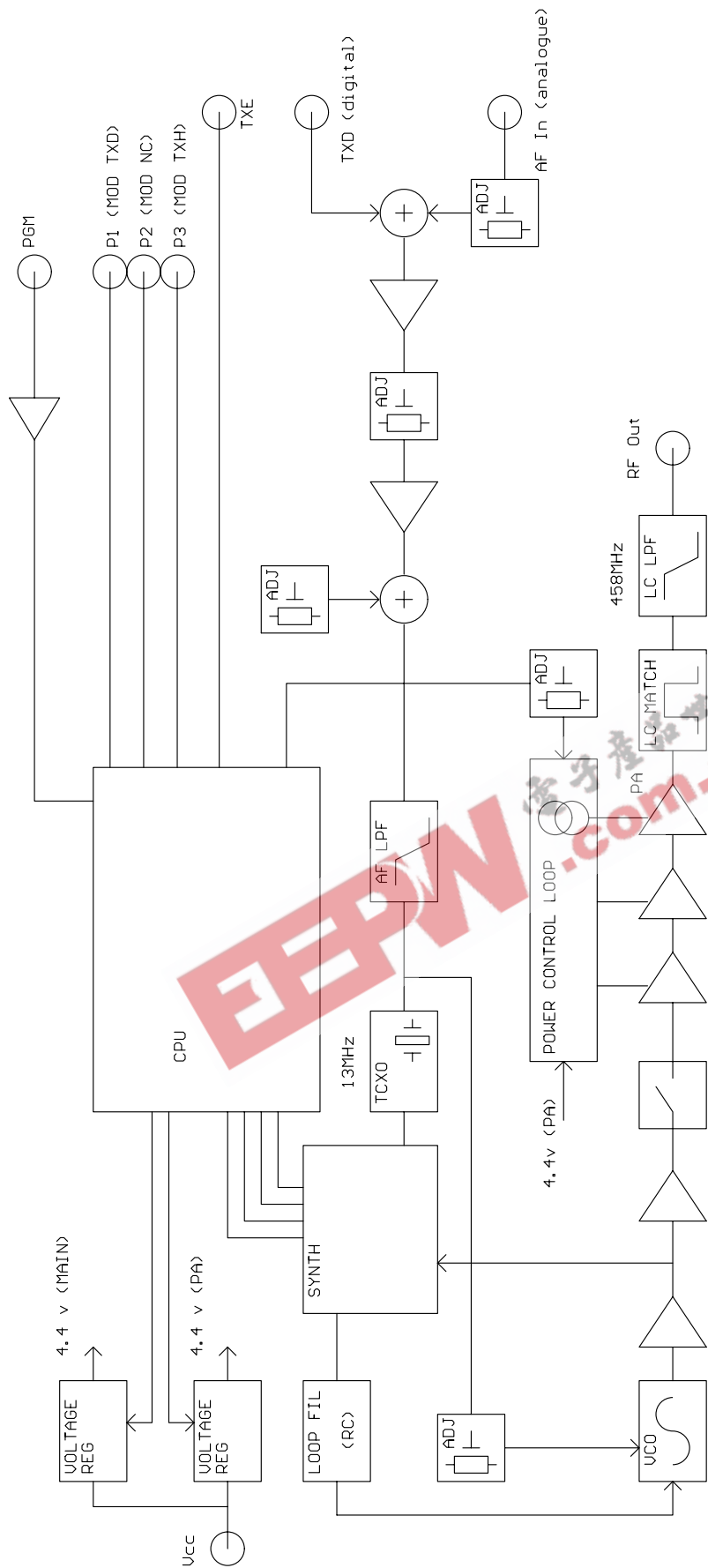

Figure 1: TX2M block diagram

RX2M-433 or RX2M-458

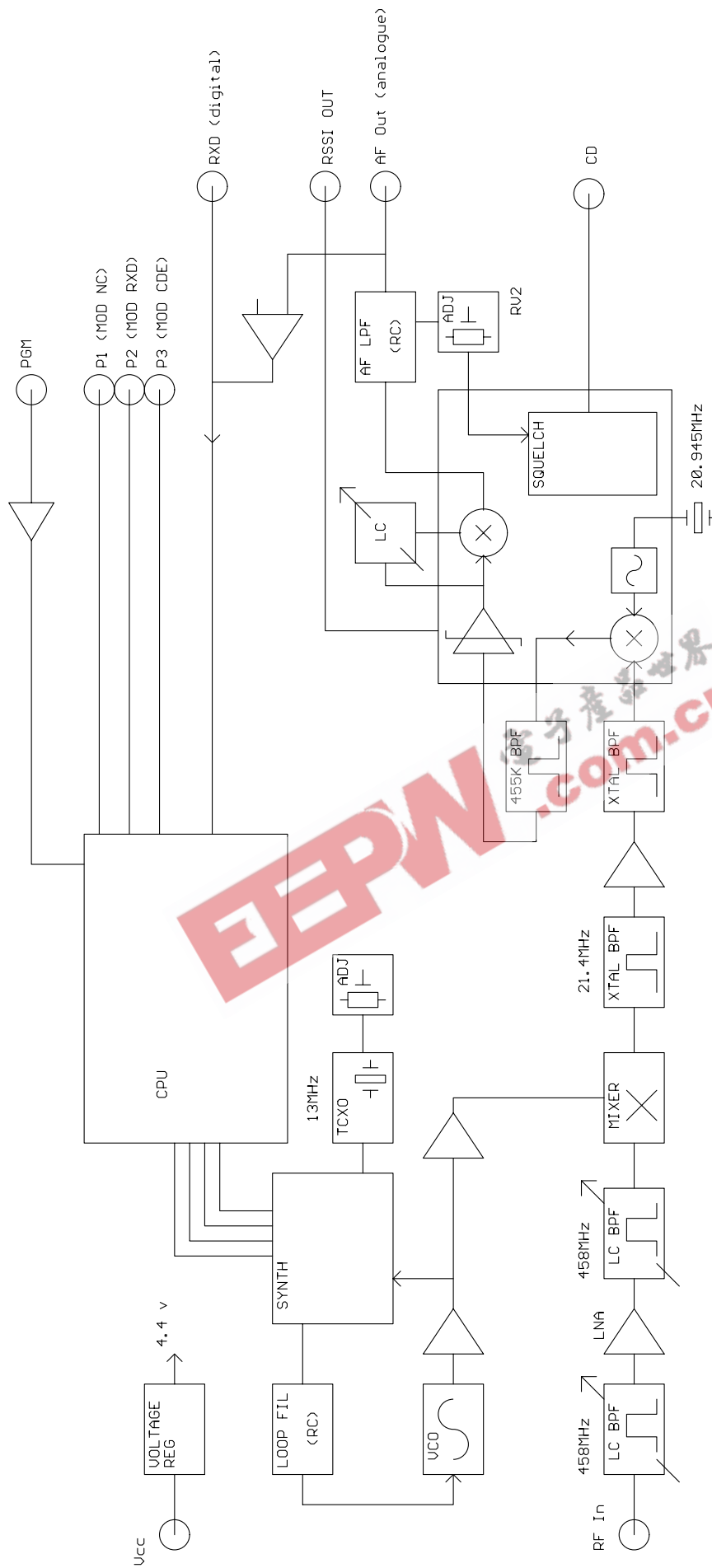

Figure 2: RX2M block diagram

Pin Description - TX2M

Pin: A	Name	Function
1	+Vin	+4.5-16V
2	Gnd	Ground

Pin: B	Name	Function
1	Gnd	RF ground
2	RF out	To the antenna
3	Gnd	RF ground

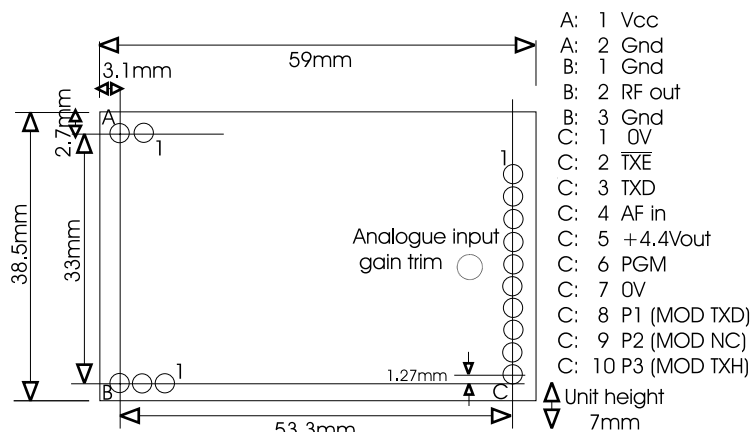

Figure 3: TX2M Footprint (Top) view

Pin: C	Name	Function
1	0V	Ground
2	TXE	Transmitter enable. Low = ON, open = off. 4k7 internal pullup to Vcc
3	TXD	DC coupled input for 3-12V CMOS logic. Leave open if unused
4	AF in	AC coupled Analogue Input. Limit to $1V_{pk-pk} \pm 10\%$ to keep distortion <1.5% and peak FM deviation >2.5kHz
5	+4.4Vout	DC supply. 75mA maximum drain. Only present when TXE is low
6	PGM	Serial programming/configuration input at RS232 level
7	0V	Ground
8	P1 (MOD TXD)	Parallel frequency select inputs. Inverted logic, 10k pullups to 4V
9	P2 (MOD NC)	
10	P3 (MOD TXH)	

Pin Description - RX2M

Pin A	Name	Function
1	+Vin	+4.5-16V
2	Gnd	Ground

Pin B	Name	Function
1	Gnd	RF ground
2	RF out	To the antenna
3	Gnd	RF ground

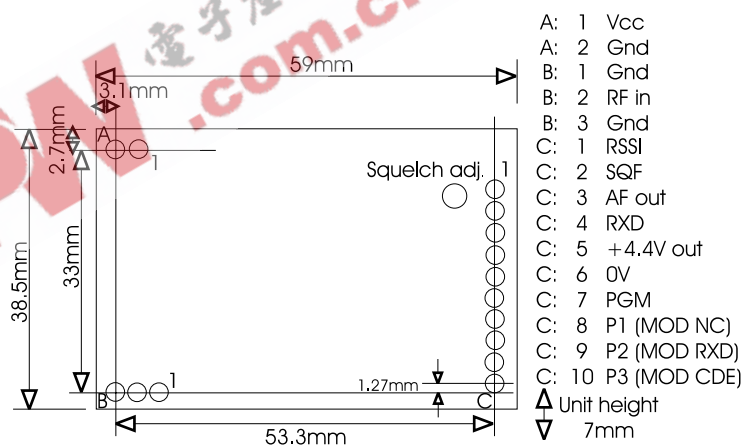

Figure 4: RX2M Footprint (Top) view

Pin C	Name	Function
1	RSSI	DC level between 0.5V and 2.5V. 60dB dynamic range
2	SQF	Noise operated carrier detect. Open collector. ON/low = no signal
3	AF out	200mV _{pk-pk} audio. DC coupled, approx 1V bias. Muted by squelch
4	RXD	Open collector output of data slicer. Need external pull-up
5	+4.4V out	DC supply. 75mA maximum drain. Present if unit is powered.
6	0V	Ground
7	PGM	Serial programming/configuration input at RS232 level
8	P1 (MOD NC)	Parallel frequency select inputs. Inverted logic, 10k pullups to 4V
9	P2 (MOD RXD)	
10	P3 (MOD CDE)	

NOTES:

1. Internal AF Input gain is factory set for $1V_{pk-pk}$ to produce 3kHz peak deviation and minimum distortion. Analogue gain may be set for an input level of $50mV - 2V_{pk-pk}$. This cannot be done without appropriate test equipment. Contact factory for details
2. Carrier detect on RX2M mutes the AF and DATA outputs when RF input signal is <-123dBm. This can be factory disabled if required.
3. There are no pullups on the open collector outputs. External pull-up resistor should be used.
4. With 1200baud modem mode enabled, parallel selection of channel is unavailable as the P1-P3 lines are used for input/output operations.

TX2M and RX2M serial interface commands

2400 baud at RS232 level. 8 bit data, no parity, 1 start bit, 1 or 2 stop bits, No flow control.
 Transmit (pin 3 on DB9) and Signal Ground (pin 5 on DB9) should be connected to PGM and 0V pin.

Command Format	Description
SINGLE nnnnn	Set value of N for single channel operation
GOCHAN xx	Serial select of channel xx (0 to 127)
LOADMX xx	Set highest permitted (serial selected) channel xx (others default to ch0)
LOADaa nnnnn	Set value of N for channel aa (channels 0 to 15)
LOADTB nnnnn	Set value of N for channel 16 (channels 17 to 127 then in sequence)
RVALUE rrrr	Enter value for R register
SETPAR	Channel selected by 3 bit parallel input (0 to 7). Disable modem
SETSER	Channel selected by most recent GOCHAN operation
SETMOD	Enable internal modem. Frequency selected by most recent GOCHAN or SINGLE
GOTEST	250Hz test tone modulated transmission
<CR>	Process entry (Carriage Return = 0D hex)
/	Clear all buffers

xx = channel number from 00 to 127
 aa = two digit channel number from 00 to 15
 nnnnn = synthesizer N register value, (up to 65535)
 rrrr = synthesizer R register value, (up to 16383)

$$N_{TX} = \frac{f_{RF}}{f_{Channelspacing}} = \frac{433.050MHz}{25kHz} = 17322 \quad R = \frac{f_{TCXO}}{f_{channelspacing}} = \frac{13MHz}{25kHz}, \text{ So } R=520$$

$$N_{RX} = \frac{f_{RF} - 21.4MHz}{f_{Channelspacing}} = \frac{433.050MHz - 21.4}{25kHz} = 16466$$

Channel Number	433MHz band	N value for TX	N value for RX	458MHz band	N value for TX	N value for RX
0	433.050	/LOAD00 17322	/LOAD00 16466	458.525	/LOAD00 18341	/LOAD00 17485
1	433.075	/LOAD01 17323	/LOAD01 16467	458.550	/LOAD01 18342	/LOAD01 17486
2	433.100	/LOAD02 17324	/LOAD02 16468	458.575	/LOAD02 18343	/LOAD02 17487
3	433.125	/LOAD03 17325	/LOAD03 16469	458.600	/LOAD03 18344	/LOAD03 17488
4	433.150	/LOAD04 17326	/LOAD04 16470	458.625	/LOAD04 18345	/LOAD04 17489
5	433.175	/LOAD05 17327	/LOAD05 16471	458.650	/LOAD05 18346	/LOAD05 17490
6	433.200	/LOAD06 17328	/LOAD06 16472	458.675	/LOAD06 18347	/LOAD06 17491
7	433.225	/LOAD07 17329	/LOAD07 16473	458.700	/LOAD07 18348	/LOAD07 17492
8	433.250	/LOAD08 17330	/LOAD08 16474	458.725	/LOAD08 18349	/LOAD08 17493
9	433.275	/LOAD09 17331	/LOAD09 16475	458.750	/LOAD09 18350	/LOAD09 17494
10	433.300	/LOAD10 17332	/LOAD10 16476	458.775	/LOAD10 18351	/LOAD10 17495
11	433.325	/LOAD11 17333	/LOAD11 16477	458.800	/LOAD11 18352	/LOAD11 17496
12	433.350	/LOAD12 17334	/LOAD12 16478	458.825	/LOAD12 18353	/LOAD12 17497
13	433.375	/LOAD13 17335	/LOAD13 16479	458.850	/LOAD13 18354	/LOAD13 17498
14	433.400	/LOAD14 17336	/LOAD14 16480	458.875	/LOAD14 18355	/LOAD14 17499
15	433.425	/LOAD15 17337	/LOAD15 16481	458.900	/LOAD15 18356	/LOAD15 17500
16	433.450	/LOADTB 17338	/LOADTB 16482	458.925	/LOADTB 18357	/LOADTB 17501
F max	434.775	/LOADMX 69	/LOADMX 69	459.100	/LOADMX 23	/LOADMX 23

Please observe the following ERC/REC 70-03 (April 2004) Annex 1 recommendation when using the Non-specific Short Range Device (SRD) band for Telemetry, Telecommand, Alarms, Data in general and other similar applications.

Frequency Band	ERP	Duty Cycle	Channel spacing	Notes
E (433.050 - 434.790MHz)	10mW	<10%	No spacing	Audio and voice signals should be avoided in the band 433.050MHz - 434.790MHz Power density limited to -13dBm/10 kHz for wideband channels with a bandwidth greater than 250 kHz
E1 (433.050 - 434.790MHz)	1mW	<100%	No spacing	
E2 (434.040 - 434.790MHz)	10mW	<100%	<25kHz	

```

tx2mrx2m - HyperTerminal
File Edit View Call Transfer Help
[Icons]
SETPAR          Set parallel frequency select mode
GOCHAN 3       Go to Channel 3 (458.600MHz)
GOCHAN 13      Go to Channel 13 (458.850MHz)
GOCHAN 23      Go to Channel 23 (459.100MHz maximum allowed Channel)
GOCHAN 22      Go to Channel 22 (459.075MHz)
GOCHAN 24      TX2M will wrap around to Ch0 if >Ch23 (459.100MHz)
/LOADMX 30     Increase highest channel to Ch30 (out of 458MHz band)
GOCHAN 30      Go to new maximum Channel 30 (459.275MHz)
/LOADMX 23     Reset the maximum Channel to regulatory band limit
/LOADTB 18360  Ch16 onwards changed from 458.925MHz to 459.000MHz
GOCHAN18       Go to new Ch18 frequency of 459.050MHz (not 458.975MHz)
GOCHAN23       Go to new maximum Ch23 frequency of 459.175MHz
/LOADTB 18357  Reset Ch16 onwards from 458.925MHz (within regulatory band)
/SETPAR       Clear buffer and return to parallel channel selection
/SETSER       Clear buffer and go to last serially selected Ch23 (458.925MHz)
GOCHAN 0       Return serially selected Channel to 0 (458.525MHz)
SETPAR        Return to channel selected by parallel pins (P1-P3) levels
SINGLE 18380   Jump to 459.500MHz without storing it on EEPROM
SETMOD        Enable internal 1200baud modem
GOTEST       Enable internal 250Hz square wave modulated test transmission
-
[Status Bar: Connected 01:00:25 Auto detect Auto detect SCROLL CAPS NUM Capture Print echo]

```

Figure 5: Serial configuration of TX2I-458-5 transmitter using HyperTerminal

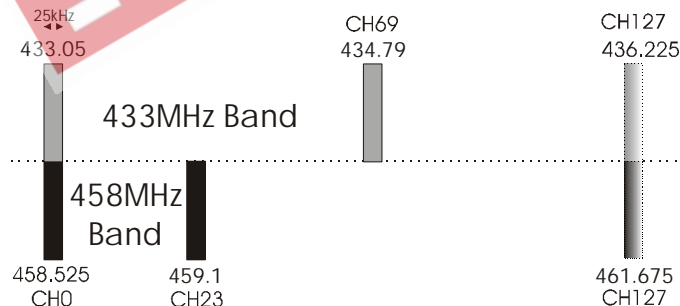

Figure 6: Maximum allowed and programmable channels

Notes:

1. A pause of at least 50ms must be allowed between command strings (EEPROM programming time) SINGLE mode does not store the N value in EEPROM. Therefore the unit is inoperative after a power down until either another valid SINGLE command is received, or mode is changed by a GOCHAN, SETPAR or SETSER command. SINGLE mode is intended for frequency agile applications.
2. /SETPAR command should be issued at the end of channel programming to put the module back into parallel frequency select mode
3. In 458MHz band, channel 12 (458.825MHz) and channel 15 (458.900MHz) are allocated specifically for fixed alarm and radio keys/vehicle paging applications respectively and should not be used for general purpose applications.

Pin description of TX2M/RX2M with Modem mode selected

The 'modem' mentioned is a 1200 baud RS232 semi-intelligent unit (Transmitter is enabled when valid serial data is present, so no separate Transmit Enable control is needed. Coding in the data stream also permits the receiver to ignore noise and only output valid serial data.

Pin Description - TX2M

Pin	Name	Function
1	0V	Ground
2	TXE	Must be tied to 0V
3	N/C	
4	N/C	
5	+4.4Vout	DC supply. 75mA maximum drain. Only present when TXE is low
6	PGM	Serial programming/configuration input at RS232 level
7	0V	Ground
8	MOD TXD (P1)	Serial data input at RS232 level
9	MOD N/C (P2)	
10	MOD TXH (P3)	Active Low Transmit Hold for continuous transmission (useful for test)

Pin Description - RX2M

Pin	Name	Function
1	RSSI	DC level between 0.5V and 2.5V. 60dB dynamic range (only valid during databursts)
2	N/C	
3	N/C	(modem tones or noise present)
4	N/C	(modem tones or noise present)
5	+4.4V out	DC supply. 75mA maximum drain. Present if unit is powered
6	0V	Ground
7	PGM	Serial programming/configuration input at RS232 level
8	MOD N/C (P1)	
9	MOD RXD (P2)	Modem Received Data at TTL level (requires RS232 driver)
10	MOD CDE (P3)	Pull low to enable Carrier Detect on modem operation (not recommended)

Both the TX2M and the RX2M should be configured to required operating frequency using GOCHAN command before starting to use the internal 1200 baud modem, because the P1-P3 pins will be used as Modem Data pins and the modem will operate on the last serially selected channel after SETMOD command is used to enable the Modem.

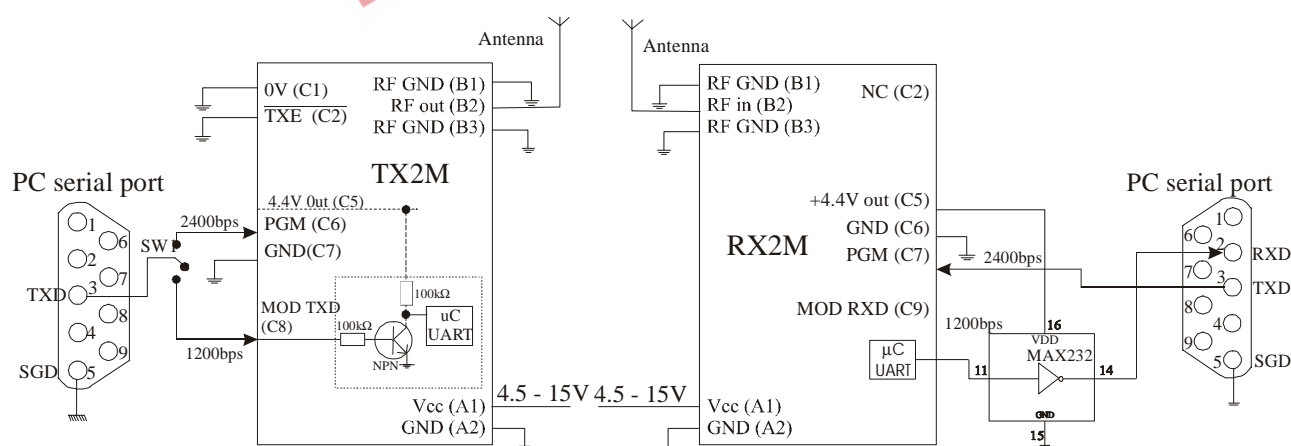

Figure 5: TX2M and RX2M interfaced to PC serial port in modem mode

Note: Baud rate used for Modem is half that of used for serial configuration. Attached RS232 devices should be set with the following: 1200bps, 8 Data bits, No Parity, 1/2 stop bits, no flow control

For TX2M, TXD (Pin 3) of a Serial Port can be switched from PGM (Pin C6) to MOD TXD (Pin C8) with no RS232 driver in between. However, in RX2M, MOD RXD (Pin C9) requires an RS232 line driver before it can be connected to RXD (pin 2) of a serial port. Some of the RS232 line drivers can be powered from the regulated +4.4V out (Pin C5).

Condensed specifications

Frequency		458.5-459.1MHz or 433-434MHz (any 5MHz band from 420-480MHz)
<i>Frequency stability</i>		+/- 1.5kHz
<i>Channel spacing</i>		25kHz (12.5kHz by special order)
<i>Number of channels</i>		128 channels controlled via RS232 interface (8 parallel selected)
Supply	<i>voltage</i>	4.5-16V
	<i>Current</i>	100mA nominal transmit 13mA receive
Operating temperature		-10 to +60 C (Storage -30 to +70 C)
Size		59 x 38 x 7 mm
Spurious radiations		Compliant with ETSI EN 300 220-3 and EN 301 489-3
Interface		
	<i>user</i>	8pin 0.1" pitch molex
	<i>Power</i>	2pin 0.1" pitch molex
	<i>RF</i>	3pin 0.1" pitch molex
Recommended PCB hole size		1.2mm (min.)
Intended approval		ETSI Radio standard EN 300 220-3 and EMC standard EN 301 489-3

Transmitter	
Output power	+20dBm(100mW) ± 1dB (factory adjustable 1 - 100mW)
TX on switching time	50 ms
Modulation type	FM, FSK (F1D, F3D)
TX modulation bandwidth	DC – 3kHz
Adjacent channel TX power	-37dBm
Inputs	analogue, data (CMOS/TTL compatible)
Receiver	
Sensitivity	-112dBm for 1 part per 1000 BER -118dBm for 12 dB SINAD
image / spurious	-70dB
Blocking	-85dB
adjacent channel	<-60dB (Tested per. ETSI EN 301 489-3)
Outputs	RSSI, carrier detect, audio, data
Power on to valid audio	28ms (no noise mute)
Power on to valid audio	45ms (with noise mute)
Power on to stable data out	50ms for 50:50 mark / space (with or without mute)

- Notes: 1. The data slicer cannot be depended upon for data waveform frequencies below 250Hz
2. When RX is on and a transmitter keys up, again a 50ms period is required to stabilise data output mark/space. i.e. allow at least 50ms of preamble

Typical current consumption of TX2M at various RF output power level is as follows:

RF output (mW)	Current (mA)
100	90
50	67
25	54
10	41
5	35
1	30

Note: These measurements taken at 433MHz (for 458MHz current consumption increases by about 5%).
RF power output can only be factory set.

Operating principle of internal modem

This device is a simplex link handling a 1200 baud asynchronous datastream (1 start, 8data, 1stop). Buffering in the transmit end handles TX startup timing requirements, while the presence of sync codes in the transmitted bursts prevents the receiver from outputting garbage in the presence of noise. No error correction or retransmission of lost packets is supported. To operate with proper +/-12V RS232 levels an external buffer (such as a MAX232) will be needed

Physically the modem code resides in the PIC microcontroller which controls the radio functions. The modem uses the internal hardware serial port of the processor.

Operation: Serial interface

Both transmit and receive modems implement a 32 byte software FIFO. At the transmit end this is used to allow for the TX2M transmitter start up time (about 32mS), while on receive it buffers arriving packets to the constant output data rate. All timing and data formatting tasks are handled by the software. The user need not worry about keying the transmitter before sending data: the link is entirely transparent.

For transmission across the link data is formatted into packets, each comprising 3 bytes of data and a sync code. If less than 3 bytes are in the transmit end FIFO then a packet is still sent, but idle state replaces the unused bytes. When the transmit end FIFO is completely emptied, then the transmitter is keyed off.

Operation: Radio interface

Raw data is not fed to the radios. A coding operation in the transmit software, and decoding in the receiver, isolate the AC coupled, potentially noisy baseband radio environment from the datastream.

The radio link is fed a continuous tone by the modem. As in biphasic codes, information is coded by varying the duration consecutive half-cycles of this tone. In our case half cycles of 500 μ s (a long, or L) and 250 μ s (a short, or S) are used.

In idle (or 'preamble') state, a sequence of Ls is sent (resembling a 1kHz tone).

A packet comprises the Synchronising (or address) part : LSSSSSSSSSSSL followed by the Data part, made up of twelve Groups (of four half cycles duration). Each Group encodes 2 data bits, so one byte is encoded by 4 Groups.

Although there are 16 possible states for a four half cycle group (from SSSS to LLLL), only four of the possible states are used for valid data:

All other possible group combinations (except LLLL) are void, and result in the entire packet being rejected by the receiver software as a noise artifact. Idle state tone (LLLL ...) is decoded as null data, but does not void the packet, as a packet containing less than 3 bytes still needs to be decoded.

The advantage of using the above coding technique:

1. Ease of decoding: Unlike biphasic, where a bit is coded as either a long half cycle or a short cycle, here all half cycles are detected separately.
2. Inherent error detection: Although only 14 sync/address 'bits' (halfcycles) are used, the following 48 'bits' (halfcycles) only code 24 real data bits, leading to enhanced noise/error discrimination (the equivalent of 5 more sync bits).
3. Comparable spectral efficiency: For a maximum transmitted baseband frequency of 2kHz, a 3 byte packet is sent in 22ms. An equivalent biphasic coded packet (comprising 19 sync + 24 data + 3 null flags) at 2kbits/sec takes 23ms

Transmitter variant

RX2M is designed to be pin and polarity compatible with existing industry standard modules. AF and Data Output are inverted relative to original transmitted signal.

The transmitter is available in two variants – TX2I and TX2M

The non-inverting transmitter called TX2M frequency modulates the carrier frequency in the normal sense whereby higher modulating voltage increases the carrier frequency and lower modulating voltage decreases the carrier frequency which results in an inverted AF and Data output on the receiver. This will be the standard module and exact plug-in replacement for existing industry standard modules.

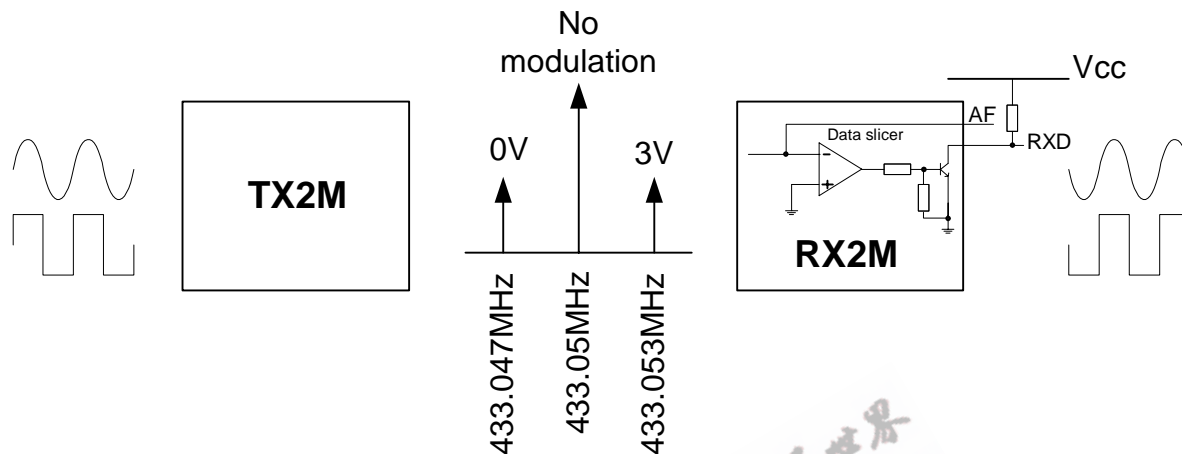

Figure 7: Data polarity change from TX2M (non-inverting) transmitter to RX2M receiver

The inverting transmitter called TX2I reverses the Frequency Modulating order whereby the higher modulating voltage decreases the carrier frequency and lower modulating voltage increases carrier frequency which results in non-inverting AF and Data output on the receiver. This variant can be used for applications where data inversion will be problematic.

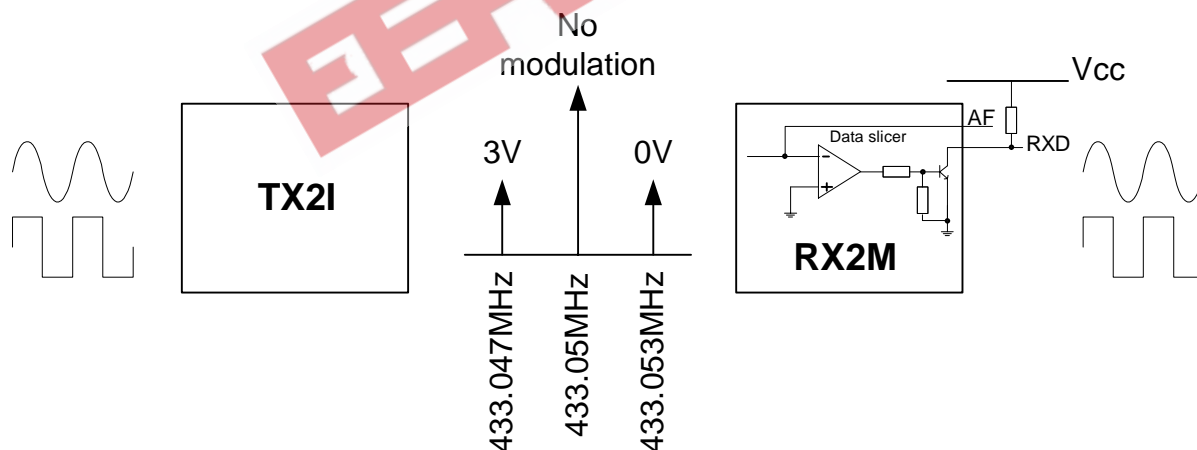

Figure 8: Data polarity change from TX2I (inverting) transmitter to RX2M receiver

Ordering information

Part Number	Description	Frequency band	Maximum data rate
TX2M-433-5	TX2M (non-inverting) transmitter	433.05MHz-434.790MHz	5kbps
TX2I-433-5	TX2I (inverting) transmitter	433.05MHz-434.790MHz	5kbps
RX2M-433-5	RX2M receiver	433.05MHz-434.790MHz	5kbps
TX2M-458-5	TX2M (non-inverting) transmitter	458.525MHz-459.100MHz	5kbps
TX2I-458-5	TX2I (inverting) transmitter	458.525MHz-459.100MHz	5kbps
RX2M-458-5	RX2M receiver	458.525MHz-459.100MHz	5kbps
TX2M-458-10	TX2M (non-inverting) transmitter	458.525MHz-459.100MHz	10kbps
TX2I-458-10	TX2I (inverting) transmitter	458.525MHz-459.100MHz	10kbps
RX2M-458-10	RX2M receiver	458.525MHz-459.100MHz	10kbps

Radiometrix Ltd
Hartcran House
231 Kenton Lane
Harrow, Middlesex
HA3 8RP
ENGLAND
Tel: +44 (0) 20 8909 9595
Fax: +44 (0) 20 8909 2233
sales@radiometrix.com
www.radiometrix.com

Copyright notice

This product data sheet is the original work and copyrighted property of Radiometrix Ltd. Reproduction in whole or in part must give clear acknowledgement to the copyright owner.

Limitation of liability

The information furnished by Radiometrix Ltd is believed to be accurate and reliable. Radiometrix Ltd reserves the right to make changes or improvements in the design, specification or manufacture of its subassembly products without notice. Radiometrix Ltd does not assume any liability arising from the application or use of any product or circuit described herein, nor for any infringements of patents or other rights of third parties which may result from the use of its products. This data sheet neither states nor implies warranty of any kind, including fitness for any particular application. These radio devices may be subject to radio interference and may not function as intended if interference is present. We do NOT recommend their use for life critical applications. The Intrastat commodity code for all our modules is: 8542 6000.

R&TTE Directive

After 7 April 2001 the manufacturer can only place finished product on the market under the provisions of the R&TTE Directive. Equipment within the scope of the R&TTE Directive may demonstrate compliance to the essential requirements specified in Article 3 of the Directive, as appropriate to the particular equipment. Further details are available on The Office of Communications (Ofcom) web site:

<http://www.ofcom.org.uk/radiocomms/ifi/>

Information Requests
Ofcom
Riverside House
2a Southwark Bridge Road
London SE1 9HA
Tel: +44 (0)845 456 3000 or 020 7981 3040
Fax: +44 (0)20 7783 4033
information.requests@ofcom.org.uk

European Radiocommunications Office (ERO)
Peblingehus
Nansensgade 19
DK 1366 Copenhagen
Tel. +45 33896300
Fax +45 33896330
ero@ero.dk
www.ero.dk