

BUCK CURRENT/VOLTAGE FED PUSH-PULL PWM CONTROLLERS

FEATURES

- Ideal for Multiple Output and/or High Voltage Output Voltage Converters
- Up to 500 kHz Operation
- High Voltage, High Current Floating Driver for Buck Converter Stage
- UC3827-1 Current Fed Controller has Push-Pull Drivers with Overlapping Conduction Periods
- UC3827-2 Voltage Fed Controller has Push-Pull Drivers with Nonoverlapping Conduction Periods
- Average Current Mode, Peak Current Mode or Voltage Mode with Input Voltage Feedforward Control for Buck Power Stage
- Wide Bandwidth, Low Offset, Differential Current Sense Amplifier
- Precise Short Circuit Current Control

DESCRIPTION

The UC3827 family of controller devices provides an integrated control solution for cascaded buck and push-pull converters. These converters are known as current fed or voltage fed push-pull converters and are ideally suited for multiple output and/or high voltage output applications. In both current fed and voltage fed modes, the push-pull switches are driven at 50% nominal duty cycles and at one half the switching frequency of the buck stage. In the current fed mode, the two switches are driven with a specified over-lap period to prevent ringing and voltage stress on the devices. In the voltage fed mode, the two switches are driven with a specified gap time between the switches to prevent shorting the transformer across the energy storage capacitor and to prohibit excessive currents flowing through the devices.

The converter's output voltage is regulated by pulse width modulation of the buck switch. The UC3827 contains complete protection and PWM control functions for the buck converter. Easy control of the floating switch is accomplished by the floating drive circuitry. The gate drive waveform is level shifted to support an input voltage up to 72 V_{DC}.

BLOCK DIAGRAM

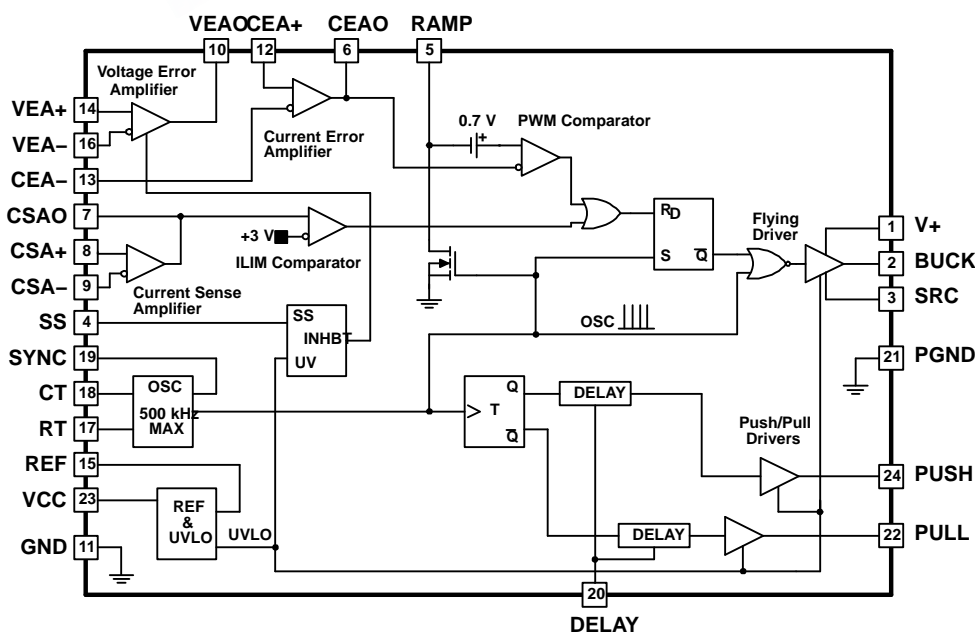

Please be aware that an important notice concerning availability, standard warranty, and use in critical applications of Texas Instruments semiconductor products and disclaimers thereto appears at the end of this data sheet.

DESCRIPTION (CONTINUED)

The UC3827 can be set up in traditional voltage mode control using input voltage feedforward technique or in current mode control. Using current mode control prevents potential core saturation of the push-pull transformer due to mismatches in timing and in component tolerances. With average current mode control, precise control of the inductor current feeding the push-pull stage is possible without the noise sensitivity associated with peak current mode control. The UC3827 average current mode loop can also be connected in parallel with the voltage regulation loop to assist only in fault conditions.

Other valuable features of the UC3827 include bidirectional synchronization capability, user programmable overlap time (UC3827-1), user programmable gap time (UC3827-2), a high bandwidth differential current sense amplifier, and soft start circuitry.

ORDERING INFORMATION⁽¹⁾

$T_A = T_J$	PUSH-PULL TOPOLOGY	PACKAGES		
		SOIC-24	PDIP-24	PLCC-28
-55°C to 125°C	Current Fed	UC1827J-1	UC1827J-1	
	Voltage Fed	UC1827J-2	UC1827J-2	
-40°C to 85°C	Current Fed	UC2827DW-1	UC2827N-1	-
	Voltage Fed	UC2827DW-2	UC2827N-2	-
0°C to 70°C	Current Fed	UC3827DW-1	UC3827N-1	UC3827Q-1
	Voltage Fed	UC3827DW-2	UC3827N-2	-

(1) The DW and Q packages are also available taped and reeled. Add a TR suffix to the device type (i.e., UC2827DWTR-1).

DISSIPATION RATINGS

PACKAGE	(θ_{JA}) JUNCTION-TO-AMBIENT TEMPERATURE (°C/W)	(θ_{JC}) JUNCTION-TO-WHAT? TEMPERATURE (°C/W)
24-pin (N)	60 ⁽¹⁾	30
24-pin (J)	70 to 90	28 ⁽²⁾
28-pin (DW)	71 to 83 ⁽³⁾	24 ⁽³⁾
28-pin (QLCC)	40-65 ⁽¹⁾	30

- (1) Specified θ_{JA} (junction-to-ambient) refers to devices mounted to 5-in² FR4 PC board with 1 oz. copper where noted. When a resistance range is given, the lower values refer to a 5-in² aluminum PC board. The test PWB is 0.062 inches thick and typically used 0.635 mm trace widths for power packages and 1.3 mm trace widths for non-power packages with a 100 x 100 mil probe land area at the end of each trace.
- (2) Specified θ_{JC} (junction-to-what?) data values stated were derived from MIL-STD-1835B which states "The baseline values shown are worst case (mean + 2s) for a 60 x 60 mil microcircuit device silicon die and applicable for devices with die sizes up to 14400 mils². For device sizes greater than 14400 mils² use the following values; dual-in-line, 11 °C/W; flat pack, 10 °C/W; pin grid array, 10 °C/W pin grid array, 10 °C/W."
- (3) Modeled data. If there is a value range given for θ_{JA} , the lower value refers to a 3 x 3 in., 1-oz, internal copper ground plane. The higher value refers to a 1 x 1 in. ground plane. All model data assumes only one trace for each non-fused lead.

ABSOLUTE MAXIMUM RATINGS⁽¹⁾

		UC2827-1 UC2827-2 UC3827-1 UC3827-2	UNITS
Supply voltage, VCC		20	
Input voltage range	CEAO, CEA+, CEA-, CSAO, CSA+, CSA-, CT, DELAY, PUSH, PULL, RAMP, RT, SS, SYNC, VEA+, VEAO,	-0.3 to 5	V
	V+ and BUCK	90	
	SRC	90-VCC	
BUCK driver	I/O continuous	±250	mA
	I/O peak	±1	A
PUSH/PULL driver	I/O continuous	±200	mA
	I/O peak	±0.8	A
Storage temperature		-65 to 150	°C
Junction temperature		-55 to 150	
Lead temperature (soldering, 10 sec)		300	

(1) Voltages are referenced to ground. Currents are positive into, negative out of the specified terminal. Consult *Packaging* section of databook for thermal limitations and considerations of packages.

CONNECTION DIAGRAMS

DIL-24 (N or J, DW PACKAGES)
(TOP VIEW)

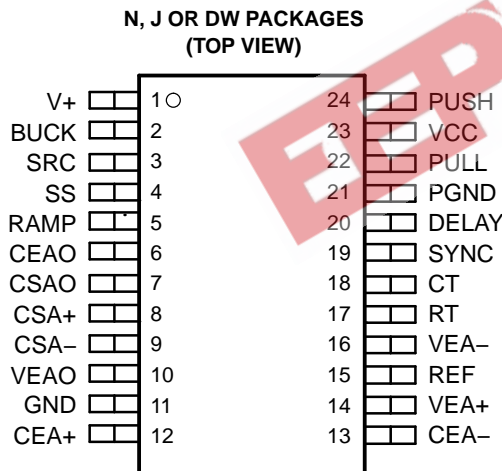

PLCC-28 (Q PACKAGE)
(TOP VIEW)

Q PACKAGE
(TOP VIEW)

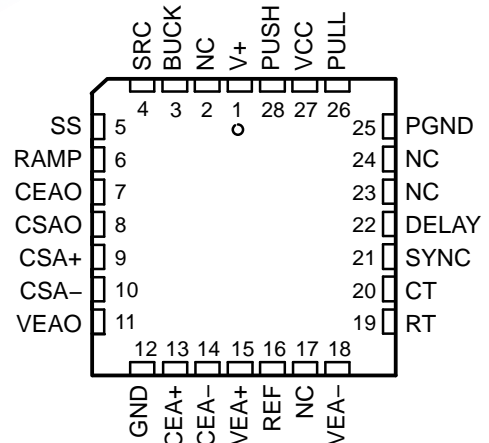

NC – No internal connection

Terminal Functions

TERMINAL			I/O	DESCRIPTION
NAME	N or DW	Q		
BUCK	2	3	O	Output of the buck PWM controller. The BUCK output is a floating driver, optimized for controlling the gate of an N-channel MOSFET. The peak sink and source currents are 1 A. V_{CC} undervoltage faults disables BUCK to an off condition (low).
CEA+	12	13	I	Non-inverting input of the current error amplifier.
CEA-	13	14	I	Inverting input of the current error amplifier
CEAO	6	7	O	Output of the current error amplifier and the inverting input of the PWM comparator of the buck converter.
CSA+	8	9	I	Noninverting input of the current sense amplifier.
CSA-	9	10	I	Inverting input of the current sense amplifier.
CSAO	7	8	O	Output of the current sense amplifier and the noninverting input of the current limit comparator. When the signal level on this pin exceeds the 3V threshold of the current limit comparator, the buck gate drive pulse is terminated. This feature is useful to implement cycle-by-cycle current limiting for the buck converter.
CT	18	20	I	Provides for the timing capacitor which is connected between CT and GND. The oscillator frequency is set by CT and a resistor R_T , connected between pin RT and GND. The CT discharge current is approximately 40 x the bias current through the resistor connected to RT. A practical maximum value for the discharge current is 20 mA. The frequency of the oscillator is given by equation ⁽¹⁾
DELAY	20	22	I	A resistor to GND programs the overlap time of the PUSH and PULL outputs of the UC3827-1 and the dead time of the PUSH and PULL outputs of the UC3827-2. The minimum value of the resistor, R_{DELAY} , is 18 k Ω . The delay or overlap time is given by equation ⁽²⁾
GND	11	12	-	Ground reference for all sensitive setup components not related to driving the outputs. They include all timing, voltage sense, current sense, and bypass components.
PGND	21	25	-	Ground connection for the PUSH and PULL outputs. PGND must be connected to GND at a single point on the printed circuit board. This is imperative to prevent large, high frequency switching currents flowing through the ground metalization inside the device.
PULL	22	26	O	Ground referenced output to drive an N-channel MOSFET. The PULL and the PUSH outputs are driving the two switches of the push-pull converter with complementary signals at close to a 50% duty cycle. Any undervoltage faults will disable PULL to an off condition (low).
PUSH	24	28	O	Ground referenced output to drive an N-channel MOSFET. The PULL and the PUSH outputs are driving the two switches of the push-pull converter with complementary signals at close to a 50% duty cycle. Any undervoltage faults disables PUSH to an off condition (low).
RAMP	5	6	I	The RAMP voltage, after a 700 mV internal level shift, is fed to the noninverting input of the buck PWM comparator. A resistor to V_{IN} and a capacitor to GND provide an input voltage feedforward signal for the buck controller in voltage mode control. In peak current mode control, the RAMP pin receives the current signal of the buck converter. In an average current mode setup, the RAMP pin has a linearly increasing ramp signal. This waveform may be generated either by connecting RAMP directly to CT, or by connecting both a resistor from V_{CC} to RAMP and a capacitor from RAMP to GND.
REF	15	16	O	The output of the +5V on board reference. Bypass this pin with a capacitor to GND. The reference is off when the chip is in undervoltage lockout mode.
RT	17	19	I	A resistor to GND programs the charge current of the timing capacitor connected to CT. The charge current approximately equals that shown in equation ⁽³⁾ . The charge current should be less than 500 μ A to keep CT's discharge peak current less than 20 mA, which is CT's maximum practical discharge value. The discharge time, which sets the maximum duty cycle, is set internally and is influenced by the charge current.
SRC	3	4	I	The source connection for the floating buck switch. The voltage on the SRC pin can exceed V_{CC} but must be lower than $90 V - V_{VCC}$. Also, during turn-off transients of the buck switch, the voltage at SRC can go to $-2V$.

$$(1) f_{OSC} = \frac{0.77}{R_{RT} \times C_{CT}} \text{ (Hz)}$$

$$(2) t_{DELAY} = \frac{R_{DELAY}}{200\Omega} \times 10^{-9} \text{ (s)}$$

$$(3) I_{RT} = \frac{2.5 V}{R_{RT}}$$

Terminal Functions (continued)

TERMINAL NAME	N or DW	Q	I/O	DESCRIPTION
SS	4	5	O	5Soft-start pin requires a capacitor to GND. During soft-start the output of the voltage error amplifier is clamped to the soft-start capacitor voltage which is slowly charged by an internal current source. In UVLO, SS is held low.
SYNC	19	21	I	A bidirectional pin for the oscillator., used to synchronize several chips to the fastest oscillator. Its input synchronization threshold is 1.4 V. The SYNC voltage is 3.6 V when the oscillator capacitor, CT, is discharged. Otherwise it is 0 V. If the recommended synchronization circuit is not used, a 1 kΩ or lower value resistor from SYNC to GND may be needed to increase the fall time of the signal at SYNC.
VCC	23	27	I	A voltage source connected to this pin supplies the power for the UC3827. It is recommended to bypass this pin to both GND and PGND ground connections with good quality high frequency capacitors
VEA+	14	15	I	Non-inverting input of the voltage error amplifier
VEA-	16	18	I	Inverting input of the voltage error amplifier
VEAO	10	11	O	Output of the voltage error amplifier
V+	1	1	I	Supply voltage for the buck output. The floating driver of the UC3827 uses the bootstrap technique which requires a reservoir capacitor to store the required energy for the on time of the buck switch. A diode must be connected from VCC to V+ to charge the reservoir capacitor. This diode must be able to withstand V _{IN} . The reservoir capacitor must be connected between V+ and SRC.

ELECTRICAL CHARACTERISTICS

Unless otherwise specified, V_{VCC} = 15 V, V_{V+} = 14.3 V, C_{CT} = 340 pF, R_{RT} = 10 kΩ, R_{DELAY} = 24.3 kΩ, V_{SRC} = V_{GND} = V_{BUCK} = V_{PUSH} = V_{PULL} outputs no load, T_J = T_A

PARAMETER		TEST CONDITIONS	MIN	TYP	MAX	UNIT
SUPPLY						
	VCC UVLO, Turn-on		8.3	8.8	9.5	V
	Hysteresis		0.9	1.2	1.5	V
I _{VCC}	Supply current start	V _{VCC} = 8 V			1000	μA
I _{VCC}	Supply current run			32	45	mA
	I _{V+} buck high		0.2	1	2	mA
VOLTAGE ERROR AMPLIFIER						
IB				0.5	3	μA
VIO					10	mV
AVOL			80	95		dB
GBW ⁽¹⁾	Gain bandwidth		1	4		MHz
V _{OL}	Low-level output voltage	I _{VEAO} = 0 μA (No load)		0.3	0.5	V
V _{OH}	High-level output voltage	I _{VEAO} = 0 μA (No load)	2.85	3	3.20	V
CURRENT SENSE AMPLIFIER						
IB				-1	-5	μA
VIO					5	mV
AVOL			80	110		dB
GBW ⁽¹⁾	Gain bandwidth		15	29		MHz
V _{OL}	Low-level output voltage	I _{CEAO} = 0 μA (No load)		0.25	0.5	V
V _{OH}	High-level output voltage	I _{CEAO} = 0 μA (No load)	3	3.3		V
CMRR	Common mode range ⁽¹⁾		-0.3		2	V
CURRENT ERROR AMPLIFIER						
IB				-1	-5	μA
VIO					10	mV
AVOL			80	110		dB

(1) Ensured by design. Not production tested.

ELECTRICAL CHARACTERISTICS (continued)

Unless otherwise specified, $V_{VCC} = 15\text{ V}$, $V_{V+} = 14.3\text{ V}$, $C_{CT} = 340\text{ pF}$, $R_{RT} = 10\text{ k}\Omega$, $R_{DELAY} = 24.3\text{ k}\Omega$, $V_{SRC} = V_{GND} = V_{BUCK} = V_{PUSH} = V_{PULL}$ outputs no load, $T_J = T_A$

PARAMETER		TEST CONDITIONS	MIN	TYP	MAX	UNIT
GBW ⁽¹⁾	Gain bandwidth	At 100 kHz, Measure Gain	2	4.5		MHz
V_{OL}		$I_{CEAO} = 0\text{ }\mu\text{A}$ (No Load)		0.25	0.5	V
V_{OH}		$I_{CEAO} = 0\text{ }\mu\text{A}$ (No Load)	3.3	3.5		V
CMRR	Common mode range ⁽¹⁾		-0.3		5	V
OSCILLATOR SECTION						
f_{OSC}	Frequency		180	220	250	kHz
$I_{CT(dsch)}$	CT discharge current	3.5V at CT when CT removed	5			mA
PWM COMPARATOR						
D_{MAX}	Minimum duty cycle	200 kHz			0%	
D_{MAX}	Maximum duty cycle	200 kHz	85%	91%	95%	
BUCK OUTPUT STAGE						
t_{RISE}	Rise time	1 nF Load ⁽²⁾		40	100	ns
t_{FALL}	Fall time	1 nF, Load		30	80	ns
V_{OH}	High-level output voltage	$I_{BUCK} = -15\text{ mA}$, $V+ -BUCK$ ⁽³⁾ $I_{BUCK} = -150\text{ mA}$, $V+ -BUCK$ ⁽³⁾		1.5	2.5	V
V_{OL}	Low-level output voltage	$I_{BUCK} = 15\text{ mA}$ ⁽⁴⁾ $I_{BUCK} = 150\text{ mA}$ ⁽⁴⁾		0.2	0.4	V
PUSH/PULL OUTPUT STAGES						
t_{RISE}	Rise time	1 nF load		50	100	ns
t_{FALL}	Fall time	1 nF load		35	100	ns
	Overlap time	UCx827-1	100	250	400	ns
	Nonoverlapping time ⁽⁶⁾	UCx827-2	100	250	500	ns
V_{OH}	High-level output voltage	$I_{PUSH/PULL} = -10\text{ mA}$, $VCC - PUSH$ ⁽⁷⁾ $I_{PUSH/PULL} = -100\text{ mA}$, $VCC - PUSH$ ⁽⁷⁾		2	3	V
V_{OL}	Low-level output voltage	$I_{PUSH/PULL} = 10\text{ mA}$ ⁽⁷⁾ $I_{PUSH/PULL} = 100\text{ mA}$ ⁽⁷⁾		0.2	0.8	V
REFERENCE						
	Reference voltage		4.8	5	5.2	V
I_{SC}	Short-circuit current	$V_{REF} = 0\text{ V}$	-35	-50	-65	mA
	Line regulation	$0.5\text{ V} < V_{VCC} < 20\text{ V}$		5	20	mV
	Load regulation	$0\text{ mA} < I_{IO} < 10\text{ mA}$		8	20	mV
SOFT START						
V_{OL}	Low-level output voltage saturation	$V_{VCC} = 7\text{ V}$		250	500	mV
I_{SS}	Soft-start current		-5	-12	-25	μA

(2) Measure the rise time from when BUCK crosses 1 V until it crosses 9 V.

(3) To force BUCK high, force $V_{CSAO} = 2.5\text{ V}$, $V_{CEAO} = 2.5\text{ V}$, a 25-k Ω pulldown resistor from RAMP to ground, and $V_{CT} = 0.5\text{ V}$.

(4) To force BUCK low, force $V_{CSAO} = 2.5\text{ V}$, $V_{CEAO} = 2.5\text{ V}$, a 10-k Ω pulldown resistor from RAMP to ground, and $V_{CT} = 3.5\text{ V}$.

(5) The overlap time is measured from the point at which the rising edge of PUSH/PULL crosses 5 V until the falling edge of PULL/PUSH crosses 5 V.

(6) The non-overlap time is measured from the point at which the falling edge of PUSH/PULL crosses 5 V until the rising edge of PULL/PUSH crosses 5 V.

(7) To toggle PUSH or PULL into a desired state, pulse CT from 0.5 V to 3.5 V. PUSH and PULL toggle on the rising edge of CT.

APPLICATION INFORMATION

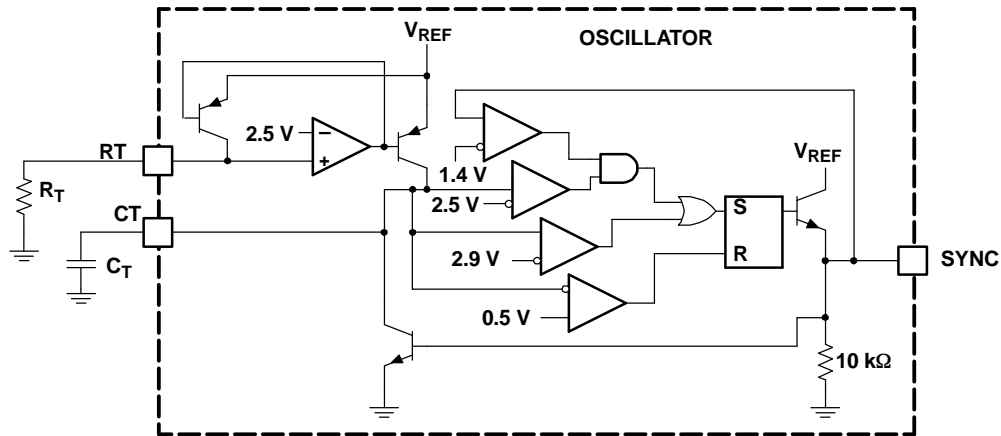

VDG-99086

Figure 1. Oscillator Block With External Connections

CIRCUIT BLOCK DESCRIPTION

PWM Oscillator

The oscillator block diagram with external connections is shown in Equation 1. A resistor (R_T) connected to pin RT sets the linear charge current:

$$I_{RT} \times \frac{2.5 \text{ V}}{R_{RT}} \quad (1)$$

The timing capacitor (C_{CT}) is linearly charged with the charge current forcing the OSC pin to charge to a 3.4 V threshold. After exceeding this threshold, the RS flip-flop is set driving CLKSYN high and R_{DEAD} low which discharges C_{CT} . C_T continues to discharge until it reaches a 0.5 V threshold and resets the RS flip-flop which repeats the charging sequence as shown in Figure 2

As shown in Figure 3, several oscillators are synchronized to the highest free running frequency by connecting 100 pF capacitors in series with each CLKSYN pin and connecting the other side of the capacitors together forming the CLKSYN bus. The CLKSYN bus is then pulled down to ground with a resistance of approximately 10k. Referring to Figure 1, the synchronization threshold is 1.4 V. The oscillator blanks any synchronization pulse that occurs when OSC is below 2.5 V. This allows units, once they discharge below 2.5 V, to continue through the current discharge and subsequent charge cycles whether or not other units on the CLKSYN bus are still synchronizing. This requires the frequency of all free running oscillators to be within 17% of each other to assure synchronization.

APPLICATION INFORMATION (continued)

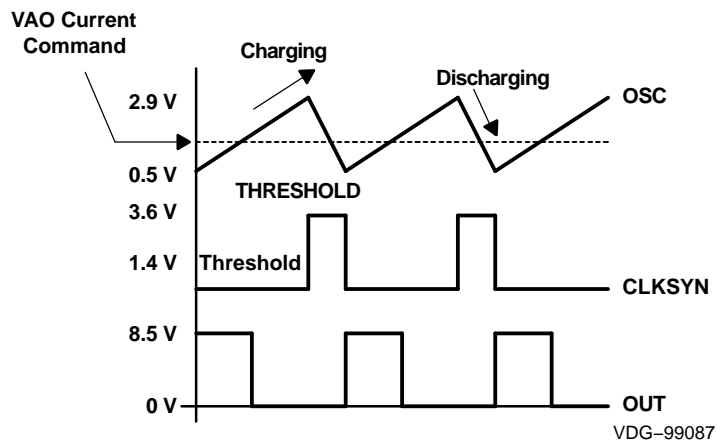

Figure 2. Oscillator and PWM Output Waveform

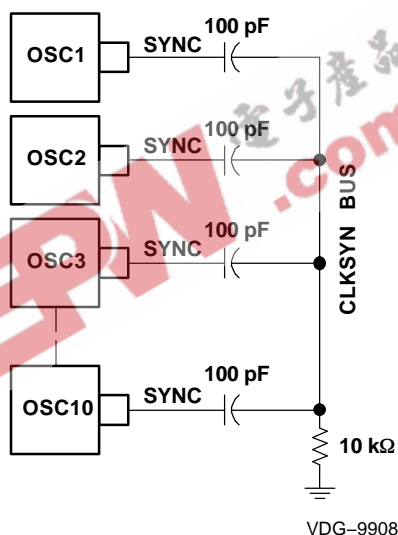

Figure 3. Oscillator Synchronization Connection Diagram

REVISION HISTORY

REVISION	DATE OF CHANGE	DESCRIPTION
SLUS365A	8/2005	Improved CMRR of CSA from (0 - 2 V) to (-0.3 - 2 V) Improved CMRR of CEA from (0 - 5 V) to (-0.3 - 5 V)

PACKAGING INFORMATION

Orderable Device	Status ⁽¹⁾	Package Type	Package Drawing	Pins	Package Qty	Eco Plan ⁽²⁾	Lead/Ball Finish	MSL Peak Temp ⁽³⁾
UC1827J-1	OBSOLETE	CDIP	J	24		TBD	Call TI	Call TI
UC1827L-1	OBSOLETE	TO/SOT	L	20		TBD	Call TI	Call TI
UC2827DW-1	ACTIVE	SOIC	DW	24	25	Green (RoHS & no Sb/Br)	CU NIPDAU	Level-3-260C-168 HR
UC2827DW-2	ACTIVE	SOIC	DW	24	25	Green (RoHS & no Sb/Br)	CU NIPDAU	Level-3-260C-168 HR
UC2827DW-2G4	ACTIVE	SOIC	DW	24	25	Green (RoHS & no Sb/Br)	CU NIPDAU	Level-3-260C-168 HR
UC2827DWTR-1	ACTIVE	SOIC	DW	24	2000	Green (RoHS & no Sb/Br)	CU NIPDAU	Level-3-260C-168 HR
UC2827DWTR-2	ACTIVE	SOIC	DW	24	2000	TBD	CU NIPDAU	Level-3-235C-168 HR
UC2827N-1	ACTIVE	PDIP	N	24	15	TBD	Call TI	Level-NA-NA-NA
UC2827N-2	ACTIVE	PDIP	N	24	15	TBD	Call TI	Level-NA-NA-NA
UC3827DW-1	ACTIVE	SOIC	DW	24	25	Green (RoHS & no Sb/Br)	CU NIPDAU	Level-3-260C-168 HR
UC3827DW-1G4	ACTIVE	SOIC	DW	24	25	Green (RoHS & no Sb/Br)	CU NIPDAU	Level-3-260C-168 HR
UC3827DW-2	ACTIVE	SOIC	DW	24	25	Green (RoHS & no Sb/Br)	CU NIPDAU	Level-3-260C-168 HR
UC3827DWTR-1	ACTIVE	SOIC	DW	24	2000	Green (RoHS & no Sb/Br)	CU NIPDAU	Level-3-260C-168 HR
UC3827DWTR-1G4	ACTIVE	SOIC	DW	24	2000	Green (RoHS & no Sb/Br)	CU NIPDAU	Level-3-260C-168 HR
UC3827DWTR-2	ACTIVE	SOIC	DW	24	2000	Green (RoHS & no Sb/Br)	CU NIPDAU	Level-3-260C-168 HR
UC3827DWTR-2G4	ACTIVE	SOIC	DW	24	2000	Green (RoHS & no Sb/Br)	CU NIPDAU	Level-3-260C-168 HR
UC3827N-1	ACTIVE	PDIP	N	24	15	TBD	Call TI	Level-NA-NA-NA
UC3827N-2	ACTIVE	PDIP	N	24	15	TBD	Call TI	Level-NA-NA-NA

⁽¹⁾ The marketing status values are defined as follows:

ACTIVE: Product device recommended for new designs.

LIFEBUY: TI has announced that the device will be discontinued, and a lifetime-buy period is in effect.

NRND: Not recommended for new designs. Device is in production to support existing customers, but TI does not recommend using this part in a new design.

PREVIEW: Device has been announced but is not in production. Samples may or may not be available.

OBSOLETE: TI has discontinued the production of the device.

⁽²⁾ Eco Plan - The planned eco-friendly classification: Pb-Free (RoHS) or Green (RoHS & no Sb/Br) - please check <http://www.ti.com/productcontent> for the latest availability information and additional product content details.

TBD: The Pb-Free/Green conversion plan has not been defined.

Pb-Free (RoHS): TI's terms "Lead-Free" or "Pb-Free" mean semiconductor products that are compatible with the current RoHS requirements for all 6 substances, including the requirement that lead not exceed 0.1% by weight in homogeneous materials. Where designed to be soldered at high temperatures, TI Pb-Free products are suitable for use in specified lead-free processes.

Green (RoHS & no Sb/Br): TI defines "Green" to mean Pb-Free (RoHS compatible), and free of Bromine (Br) and Antimony (Sb) based flame retardants (Br or Sb do not exceed 0.1% by weight in homogeneous material)

⁽³⁾ MSL, Peak Temp. -- The Moisture Sensitivity Level rating according to the JEDEC industry standard classifications, and peak solder temperature.

Important Information and Disclaimer:The information provided on this page represents TI's knowledge and belief as of the date that it is

provided. TI bases its knowledge and belief on information provided by third parties, and makes no representation or warranty as to the accuracy of such information. Efforts are underway to better integrate information from third parties. TI has taken and continues to take reasonable steps to provide representative and accurate information but may not have conducted destructive testing or chemical analysis on incoming materials and chemicals. TI and TI suppliers consider certain information to be proprietary, and thus CAS numbers and other limited information may not be available for release.

In no event shall TI's liability arising out of such information exceed the total purchase price of the TI part(s) at issue in this document sold by TI to Customer on an annual basis.

EEPW 电子產品世界
.com.cn

MECHANICAL DATA

MCDI004A – JANUARY 1995 – REVISED NOVEMBER 1997

J (R-GDIP-T**)

CERAMIC DUAL-IN-LINE PACKAGE

24 PINS SHOWN

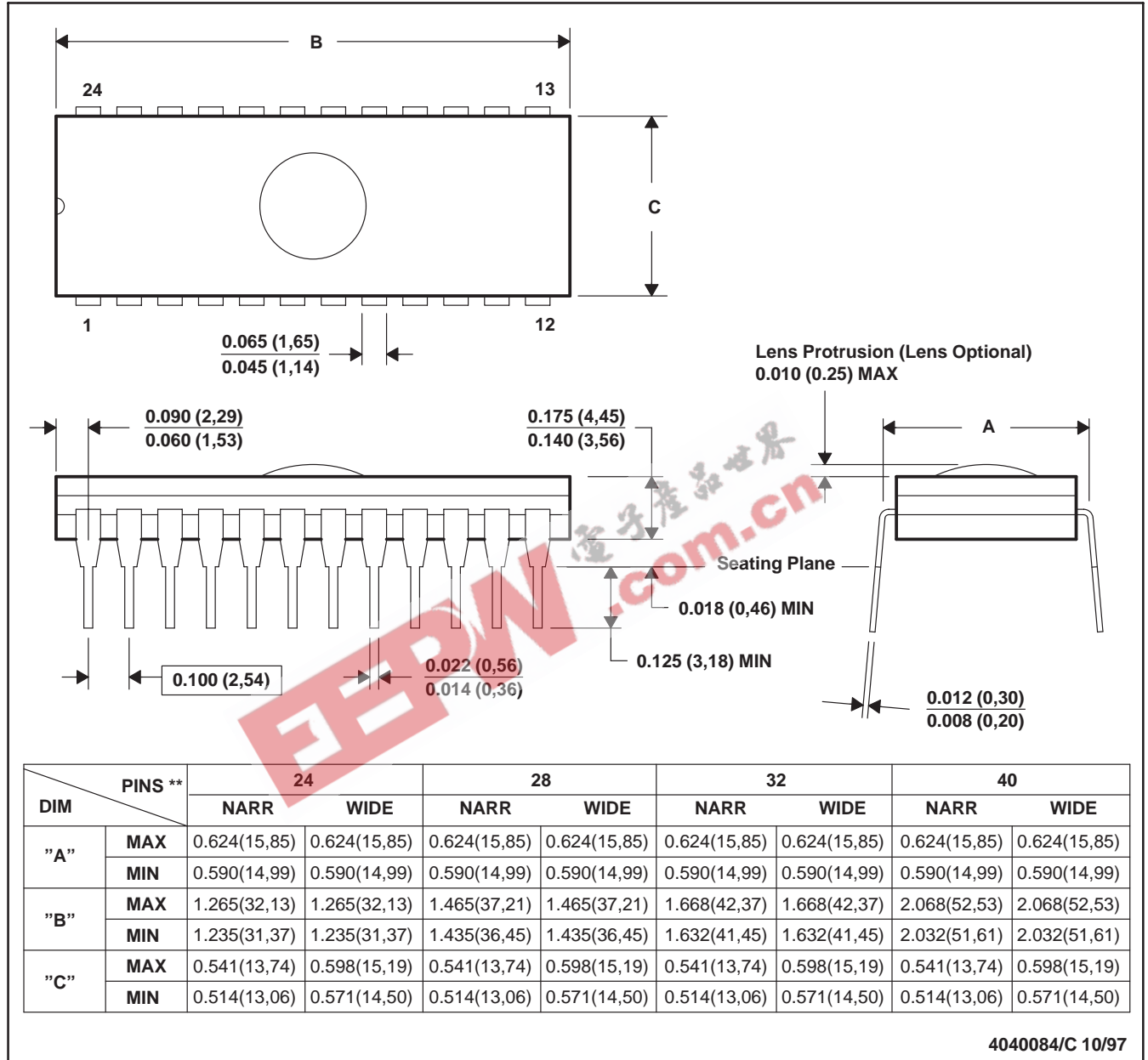

- NOTES: A. All linear dimensions are in inches (millimeters).
 B. This drawing is subject to change without notice.
 C. Window (lens) added to this group of packages (24-, 28-, 32-, 40-pin).
 D. This package can be hermetically sealed with a ceramic lid using glass frit.
 E. Index point is provided on cap for terminal identification.

MECHANICAL DATA

MPDI006B – SEPTEMBER 2001 – REVISED APRIL 2002

N (R-PDIP-T24)

PLASTIC DUAL-IN-LINE

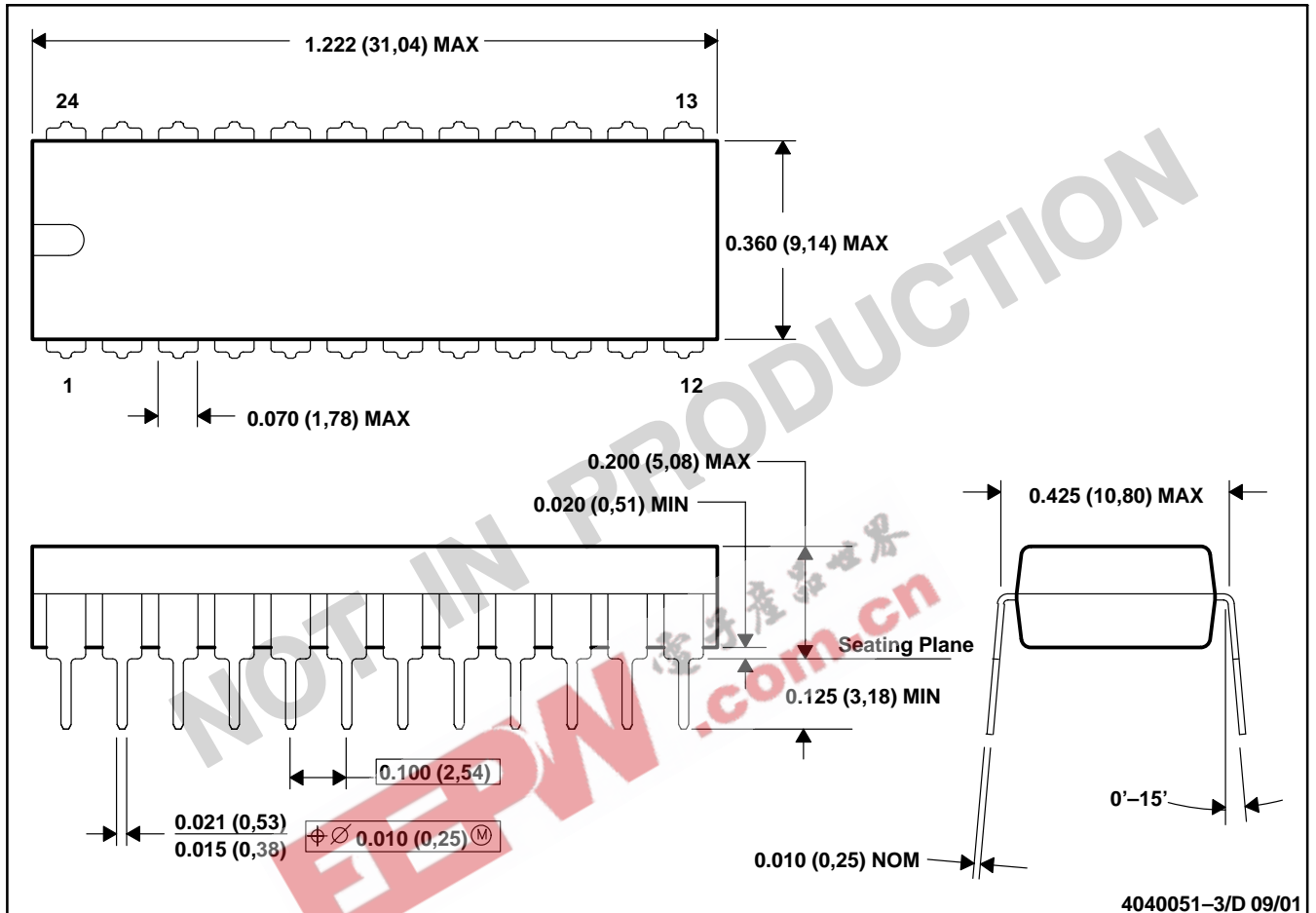

- NOTES:
- A. All linear dimensions are in inches (millimeters).
 - B. This drawing is subject to change without notice.
 - C. Falls within JEDEC MS-010

MECHANICAL DATA

MPDI008 – OCTOBER 1994

N (R-PDIP-T)**

PLASTIC DUAL-IN-LINE PACKAGE

24 PIN SHOWN

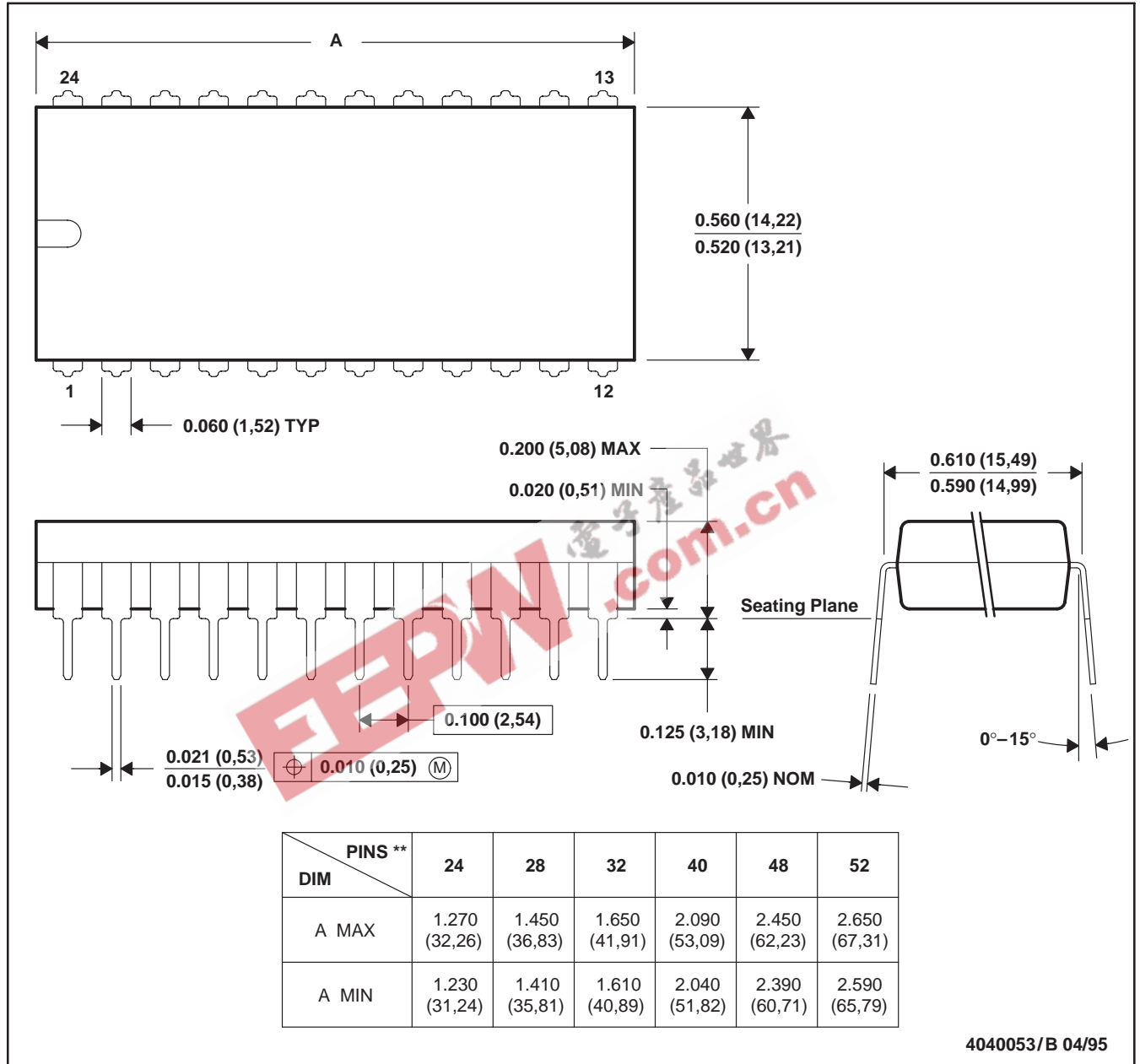

- NOTES: A. All linear dimensions are in inches (millimeters).
 B. This drawing is subject to change without notice.
 C. Falls within JEDEC MS-011
 D. Falls within JEDEC MS-015 (32 pin only)

MECHANICAL DATA

DW (R-PDSO-G24)

PLASTIC SMALL-OUTLINE PACKAGE

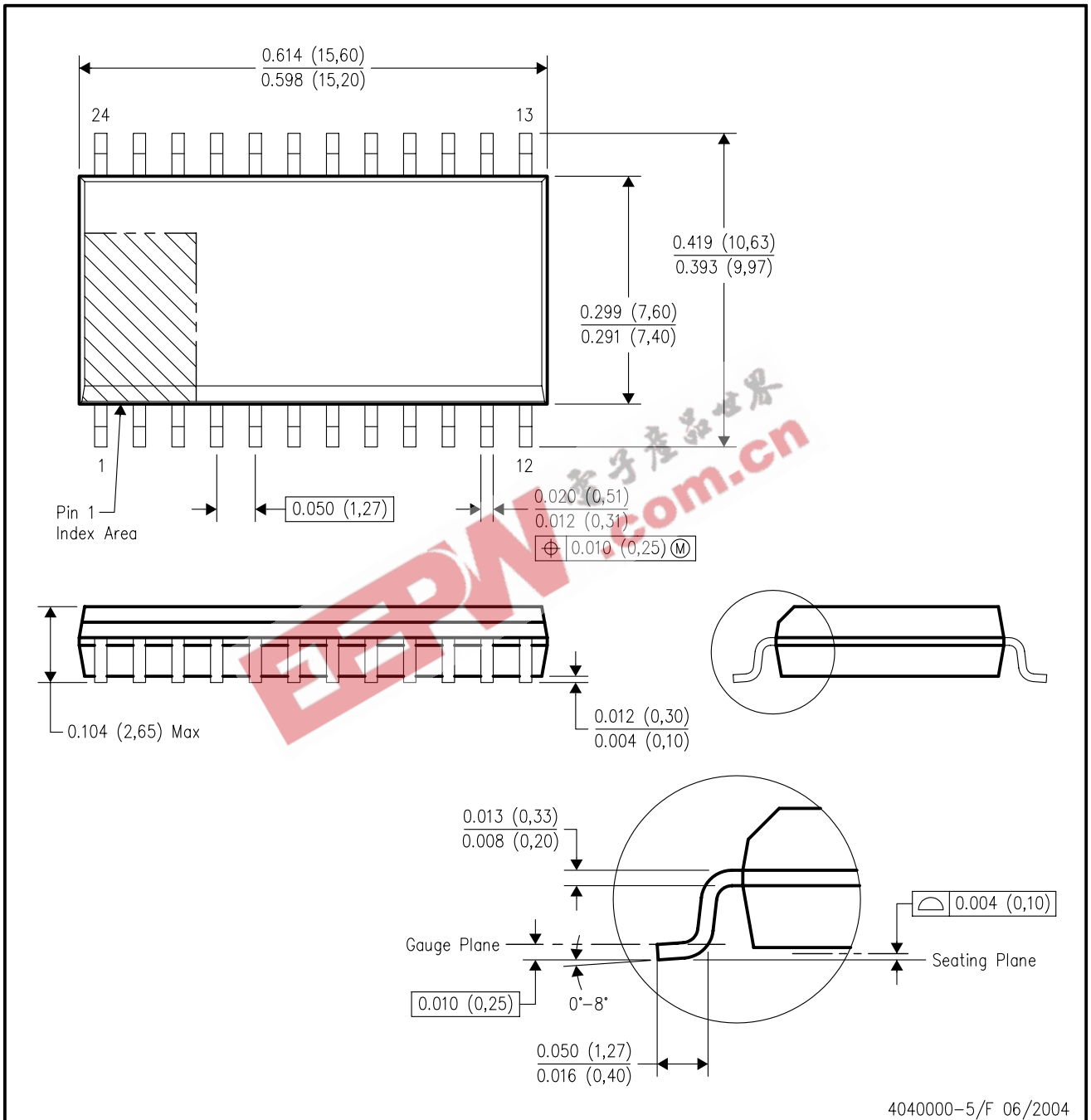

- NOTES:
- All linear dimensions are in inches (millimeters).
 - This drawing is subject to change without notice.
 - Body dimensions do not include mold flash or protrusion not to exceed 0.006 (0,15).
 - Falls within JEDEC MS-013 variation AD.

IMPORTANT NOTICE

Texas Instruments Incorporated and its subsidiaries (TI) reserve the right to make corrections, modifications, enhancements, improvements, and other changes to its products and services at any time and to discontinue any product or service without notice. Customers should obtain the latest relevant information before placing orders and should verify that such information is current and complete. All products are sold subject to TI's terms and conditions of sale supplied at the time of order acknowledgment.

TI warrants performance of its hardware products to the specifications applicable at the time of sale in accordance with TI's standard warranty. Testing and other quality control techniques are used to the extent TI deems necessary to support this warranty. Except where mandated by government requirements, testing of all parameters of each product is not necessarily performed.

TI assumes no liability for applications assistance or customer product design. Customers are responsible for their products and applications using TI components. To minimize the risks associated with customer products and applications, customers should provide adequate design and operating safeguards.

TI does not warrant or represent that any license, either express or implied, is granted under any TI patent right, copyright, mask work right, or other TI intellectual property right relating to any combination, machine, or process in which TI products or services are used. Information published by TI regarding third-party products or services does not constitute a license from TI to use such products or services or a warranty or endorsement thereof. Use of such information may require a license from a third party under the patents or other intellectual property of the third party, or a license from TI under the patents or other intellectual property of TI.

Reproduction of information in TI data books or data sheets is permissible only if reproduction is without alteration and is accompanied by all associated warranties, conditions, limitations, and notices. Reproduction of this information with alteration is an unfair and deceptive business practice. TI is not responsible or liable for such altered documentation.

Resale of TI products or services with statements different from or beyond the parameters stated by TI for that product or service voids all express and any implied warranties for the associated TI product or service and is an unfair and deceptive business practice. TI is not responsible or liable for any such statements.

Following are URLs where you can obtain information on other Texas Instruments products and application solutions:

Products		Applications	
Amplifiers	amplifier.ti.com	Audio	www.ti.com/audio
Data Converters	dataconverter.ti.com	Automotive	www.ti.com/automotive
DSP	dsp.ti.com	Broadband	www.ti.com/broadband
Interface	interface.ti.com	Digital Control	www.ti.com/digitalcontrol
Logic	logic.ti.com	Military	www.ti.com/military
Power Mgmt	power.ti.com	Optical Networking	www.ti.com/opticalnetwork
Microcontrollers	microcontroller.ti.com	Security	www.ti.com/security
		Telephony	www.ti.com/telephony
		Video & Imaging	www.ti.com/video
		Wireless	www.ti.com/wireless

Mailing Address: Texas Instruments
Post Office Box 655303 Dallas, Texas 75265