

7003

HIGH-VOLTAGE, HIGH-CURRENT DARLINGTON ARRAY

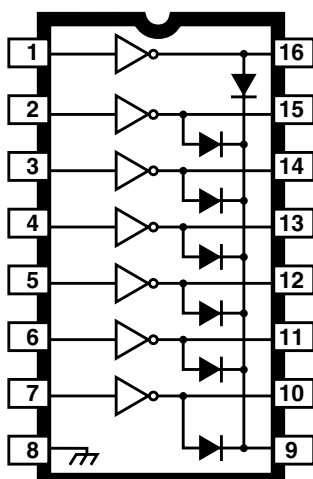

Dwg. No. A-9594

Note the ULN7003A (DIP) and the ULN7003LW (SOIC) are electrically identical and share a common terminal number assignment.

ABSOLUTE MAXIMUM RATINGS at $T_A = +25^\circ\text{C}$

Output Voltage, V_{CEX}	135 V
Output Sustaining Voltage, $V_{CE(sus)}$	90 V
Output Current, I_C	300 mA
Input Current, I_{IN}	25 mA
Package Power Dissipation, P_D	See Graph
Operating Temperature Range, T_A	-20°C to $+85^\circ\text{C}$
Storage Temperature Range, T_S	-55°C to $+150^\circ\text{C}$

Output current may be limited by duty cycle, number of drivers operating, ambient temperature, and heat sinking. Under any set of conditions, do not exceed the specified maximum current rating or a junction temperature of 150°C .

Integrating seven high-voltage, high-current npn Darlington into a monolithic power array, the ULN7003A AND ULN7003LW are designed for interfacing between TTL or CMOS logic and a variety of peripheral loads. The seven open-collector Darlington outputs are specified for 135 V minimum breakdown and 90 V minimum sustaining. Included are integral power diodes for switching inductive loads. Typical applications include relays, lamps, print heads and hammers, solenoids, and level shifting to power discretes.

The ULN7003A/LW include input current-limiting resistors compatible with the drive capabilities of TTL and (most) CMOS operating at a nominal logic supply of 5 V. Operation with 12 V CMOS may require additional input current limiting.

The high sustaining voltage rating of this power array makes it ideal for inductive load applications where Zener diode flyback techniques are used. The increased flyback voltage provides a much faster inductive load turn-off current decay that is especially useful with dc stepper motors, solenoids, and print heads.

Both devices are pinned with outputs opposite inputs to facilitate ease of circuit board layout. The ULN7003A is supplied in a 16-pin plastic dual in-line package with a copper lead frame to maximize device power dissipation capabilities. The ULN7003LW is furnished in a 16-lead small-outline wide-body package for surface-mount applications.

FEATURES

- 135 V Minimum Output Breakdown
- 90 V Minimum Sustaining Voltage
- 300 mA Output Current
- Internal High-Current Clamp Diodes
- Logic-Compatible Inputs

Always order by complete part number:

Part Number	Package
ULN7003A	16-Pin DIP
ULN7003LW	16-Lead SOIC

7003 HIGH-VOLTAGE, HIGH-CURRENT DARLINGTON ARRAY

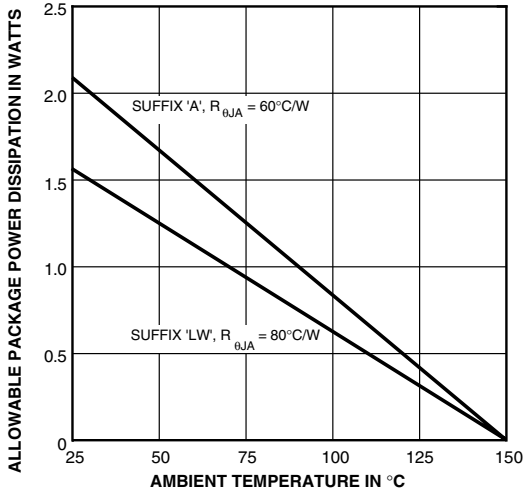

Dwg. GP-018B

A Zener diode can be used to increase the flyback voltage. This gives a much faster inductive load turn-OFF current decay. The maximum Zener voltage plus the load supply voltage plus the internal diode forward voltage must not exceed the device's rated sustaining voltage.

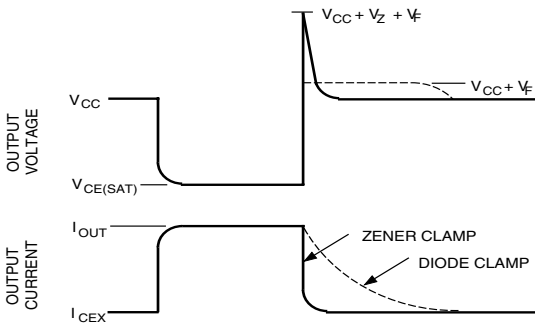

Dwg. WP-001

PARTIAL SCHEMATIC (one of seven drivers)

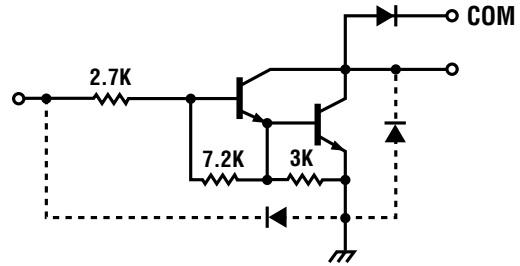

Dwg. No. A-9651

SWITCHING DELAY TEST CIRCUIT

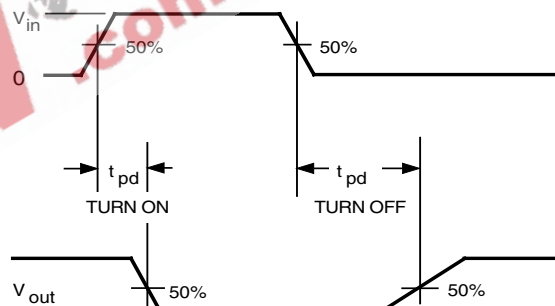

Dwg. WP-010

$V_{in} = 3.5\text{ V}$ for ULN7003A

Dwg. No. WP-010

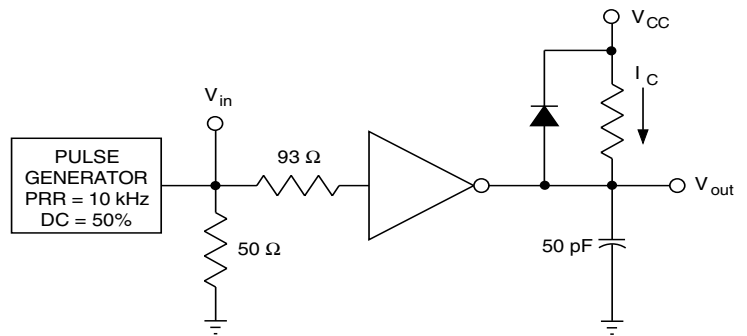

Dwg. EP-020

7003
HIGH-VOLTAGE,
HIGH-CURRENT
DARLINGTON ARRAY

ELECTRICAL CHARACTERISTICS at $T_A = +25^\circ\text{C}$ (unless otherwise noted).

Characteristic	Symbol	Test Conditions	Limits			Units
			Min.	Typ.	Max.	
Output Leakage Current	I_{CEX}	$V_{CE} = 135\text{ V}$	—	—	50	μA
		$V_{CE} = 135\text{ V}, T_A = +70^\circ\text{C}$	—	—	100	μA
Output Sustaining Voltage	$V_{CE(sus)}$	$I_C = 250\text{ mA}, L = 2\text{ mH}$	90	—	—	V
Output Saturation Voltage	$V_{CE(SAT)}$	$I_C = 100\text{ mA}, I_{IN} = 250\text{ }\mu\text{A}$	—	1.1	1.3	V
		$I_C = 250\text{ mA}, I_{IN} = 350\text{ }\mu\text{A}$	—	1.3	1.6	V
Input Current	$I_{IN(ON)}$	$V_{IN} = 3.85\text{ V}$	—	0.93	1.35	mA
	$I_{IN(OFF)}$	$I_C = 500\text{ }\mu\text{A}, T_A = +70^\circ\text{C}$	50	65	—	μA
Input Voltage	$V_{IN(ON)}$	$V_{CE} = 2.0\text{ V}, I_C = 200\text{ mA}$	—	—	2.4	V
		$V_{CE} = 2.0\text{ V}, I_C = 250\text{ mA}$	—	—	2.7	V
Input Capacitance	C_{IN}		—	15	25	pF
Switching Delay	t_{pd}	Turn On, $I_C = 250\text{ mA}$	—	0.05	1.0	μs
		Turn Off, $I_C = 250\text{ mA}$	—	0.5	1.0	μs
Clamp Diode Leakage Current	I_R	$V_R = 150\text{ V}$	—	—	50	μA
		$V_R = 150\text{ V}, T_A = +70^\circ\text{C}$	—	—	100	μA
Clamp Diode Forward Voltage	V_F	$I_F = 250\text{ mA}$	—	1.7	2.0	V

Typical Data is for design information only.

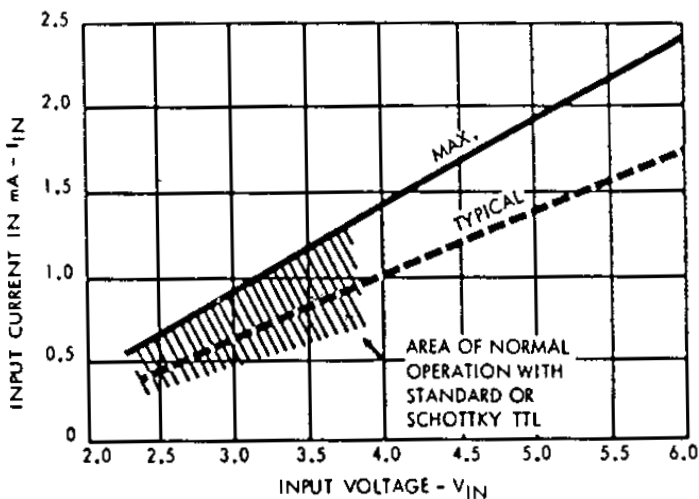

**TYPICAL INPUT CURRENT
AS A FUNCTION OF INPUT VOLTAGE**
at $T_A = +25^\circ\text{C}$

7003
HIGH-VOLTAGE,
HIGH-CURRENT
DARLINGTON ARRAY

**ALLOWABLE PEAK COLLECTOR CURRENT AS A
 FUNCTION OF DUTY CYCLE**

ULN7003A at $T_A = +50^\circ\text{C}$

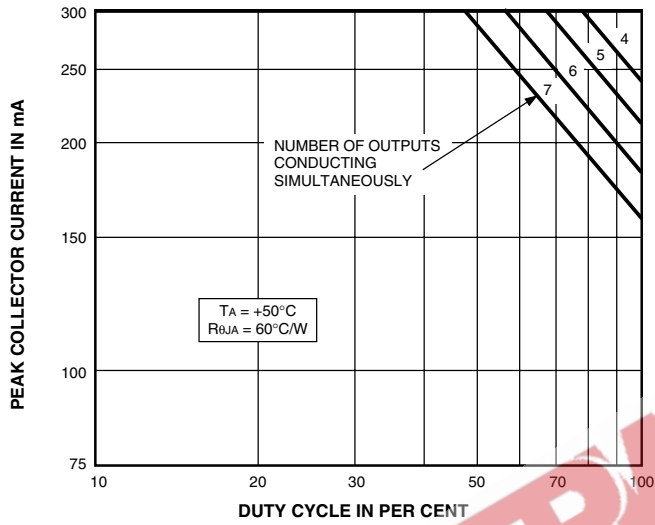

ULN7003A at $T_A = +70^\circ\text{C}$

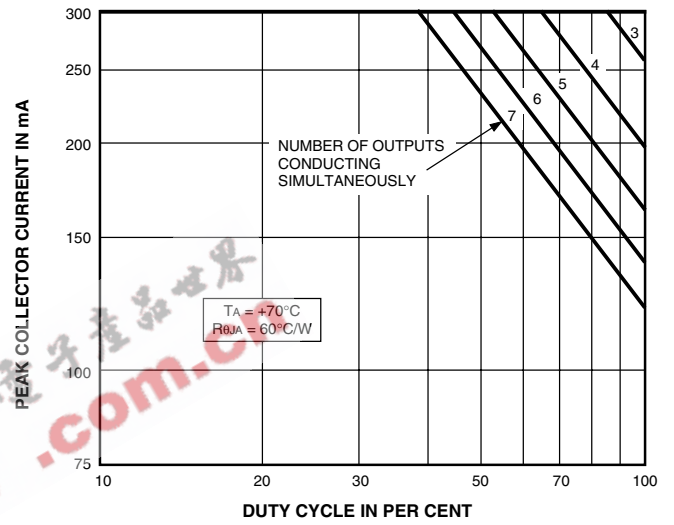

ULN7003LW at $T_A = +50^\circ\text{C}$

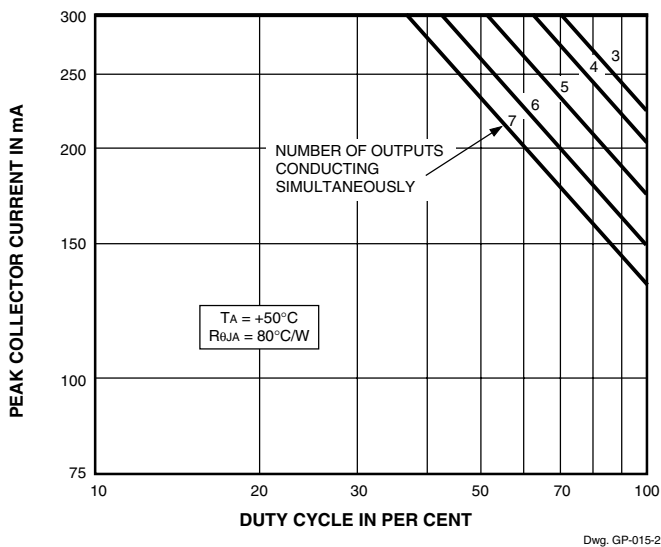

ULN7003LW at $T_A = +70^\circ\text{C}$

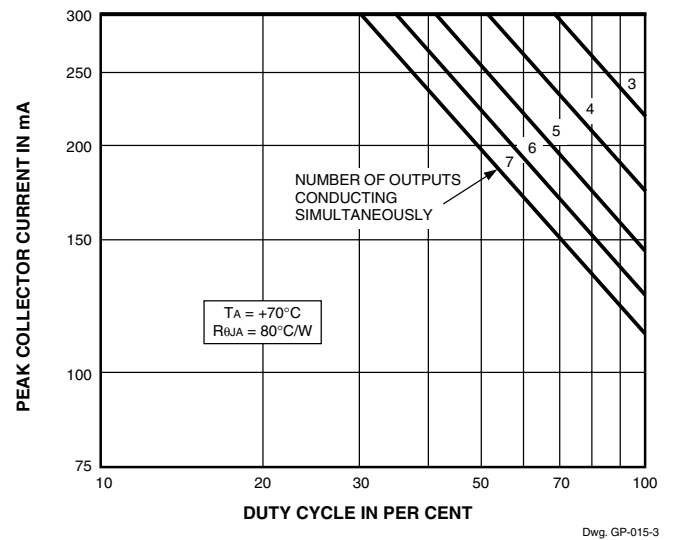

7003 HIGH-VOLTAGE, HIGH-CURRENT DARLINGTON ARRAY

ULN7003A Dimensions in Inches (controlling dimensions)

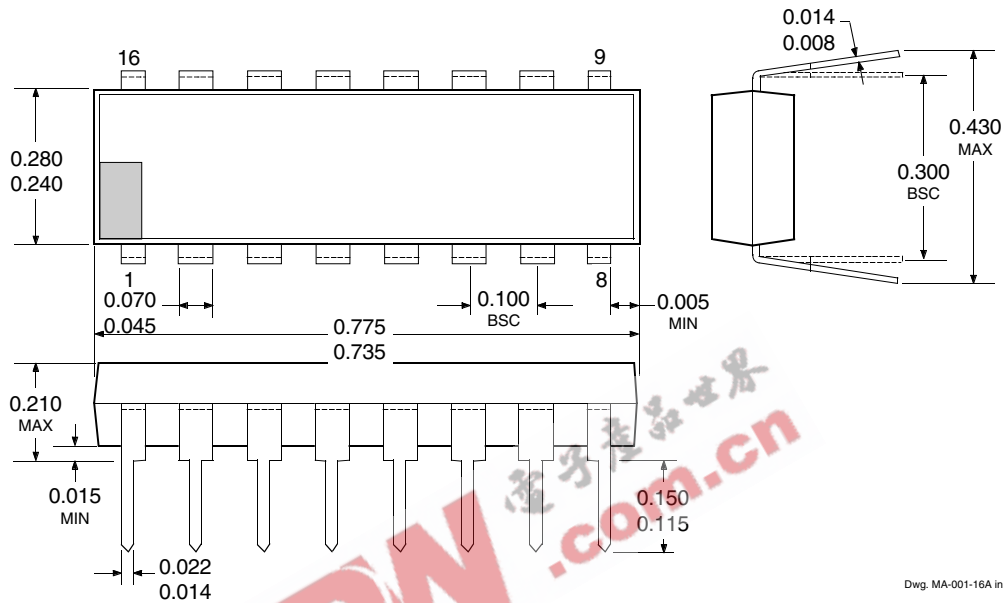

Dimensions in Millimeters (for reference only)

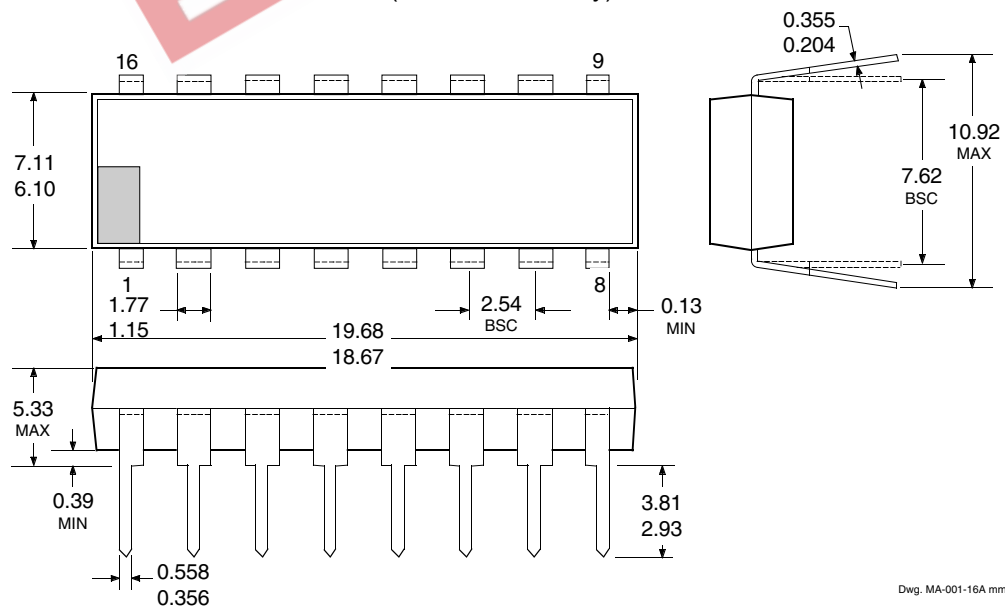

- NOTES:
1. Lead thickness is measured at seating plane or below.
 2. Lead spacing tolerance is non-cumulative.
 3. Exact body and lead configuration at vendor's option within limits shown.
 4. Supplied in standard sticks/tubes of 25 devices.

7003
HIGH-VOLTAGE,
HIGH-CURRENT
DARLINGTON ARRAY

ULN7003LW
 Dimensions in Inches
 (for reference only)

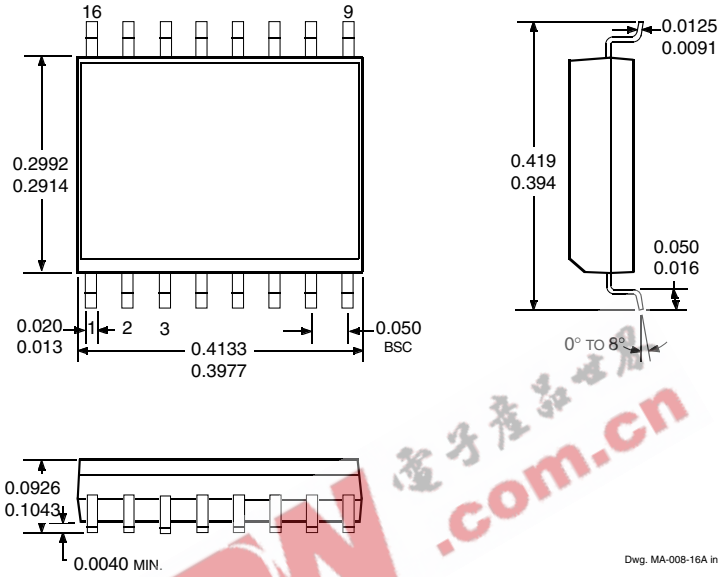

Dimensions in Millimeters
 (controlling dimensions)

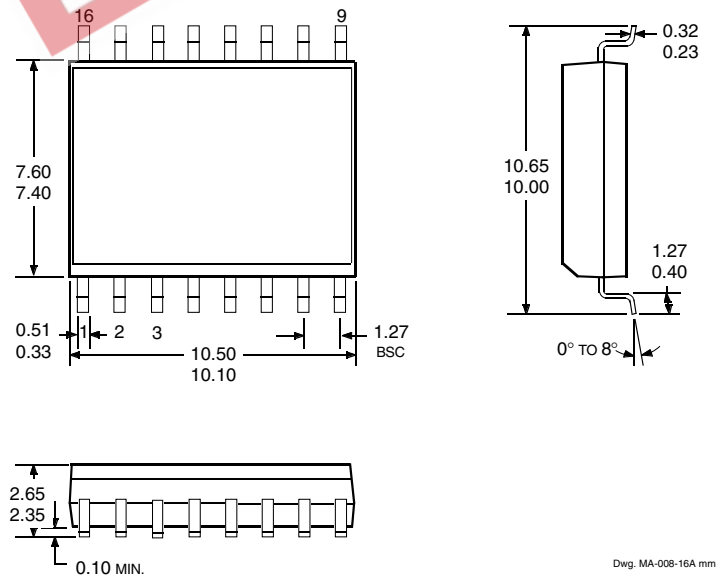

- NOTES: 1. Exact body and lead configuration at vendor's option within limits shown.
 2. Lead spacing tolerance is non-cumulative.
 3. Supplied in standard sticks/tubes of 47 devices or add "TR" to part number for tape and reel.

7003
HIGH-VOLTAGE,
HIGH-CURRENT
DARLINGTON ARRAY

EEPW 电子產品世界
.com.cn

The products described here are manufactured under one or more U.S. patents or U.S. patents pending.

Allegro MicroSystems, Inc. reserves the right to make, from time to time, such departures from the detail specifications as may be required to permit improvements in the performance, reliability, or manufacturability of its products. Before placing an order, the user is cautioned to verify that the information being relied upon is current.

Allegro products are not authorized for use as critical components in life-support devices or systems without express written approval.

The information included herein is believed to be accurate and reliable. However, Allegro MicroSystems, Inc. assumes no responsibility for its use; nor for any infringement of patents or other rights of third parties which may result from its use.

7003
HIGH-VOLTAGE,
HIGH-CURRENT
DARLINGTON ARRAY

**HIGH-VOLTAGE (≥ 60 V) PERIPHERAL POWER
AND DISPLAY DRIVERS**

IN ORDER OF 1) OUTPUT VOLTAGE, 2) OUTPUT CURRENT, 3) NUMBER OF DRIVERS

Output Ratings*			Features					Part Number †
V	mA	#	Serial Input	Latched Drivers	Diode Clamp	Saturated Outputs	Internal Protection	
60	-25	8	–	X	–	–	–	5815
	-25	10	X	X	Active Pull-Down	–	–	5810-F and 6809/10
	-25	12	X	X	Active Pull-Down	–	–	5811 and 6811
	-25	20	X	X	Active Pull-Down	–	–	5812-F and 6812
	-25	32	X	X	Active Pull-Down	–	–	5818-F and 6818
	300	4	–	–	X	X	X	2557
	600	4	–	–	–	X	X	2547
	600	4	–	–	X	X	X	2549
	700	4	–	–	X	X	X	2559
	700	4	–	–	X	X	X	2543
4000	4	–	–	X	–	–	2944	
80	-350	8	–	–	X	–	–	2983 and 2984
	350	8	X	X	–	–	–	5822
	350	8	X	X	X	–	–	5842
	-350	8	X	X	X	–	–	5890
	1500	4	–	–	–	–	–	2065 and 2069
	4000	4	–	–	X	–	–	2879
85	-25	8	–	–	–	–	–	6118
95	300	7	–	–	X	–	–	2023
	300	8	–	–	X	–	–	2823
	350	7	–	–	X	–	–	2024
	350	8	–	–	X	–	–	2824

* Current is maximum test condition; voltage is absolute maximum allowable.

Negative current is defined as coming out of (sourcing) the output.

† Complete part number includes additional characters to indicate operating temperature range and package style.