

## 16-BIT TO 8-BIT SPDT GIGABIT LAN SWITCH WITH LED SWITCH AND ENHANCED ESD PROTECTION

### FEATURES

- Wide Bandwidth (BW = 950 MHz Typ)
- Low Crosstalk ( $X_{TALK} = -37$  dB Typ)
- Low Bit-to-Bit Skew ( $t_{sk(o)} = 100$  ps Max)
- Low and Flat ON-State Resistance ( $r_{on} = 4 \Omega$  Typ,  $r_{on(Flat)} = 0.5 \Omega$  Typ)
- Low Input/Output Capacitance ( $C_{ON} = 8$  pF Typ)
- Rail-to-Rail Switching on Data I/O Ports (0 to 3.6 V)
- $V_{CC}$  Operating Range From 3 V to 3.6 V
- Latch-Up Performance Exceeds 100 mA Per JESD 78, Class II

### ESD Performance

- 8-kV IEC61000-4-2, Contact Discharge on Switch IOs
- 3-kV Human Body Model Per JESD22-A114E
- 14-kV Human Body Model (Switch Pins to GND)

### APPLICATIONS

- 10/100/1000 Base-T Signal Switching
- Differential (LVDS, LVPECL) Signal Switching
- Audio/Video Switching
- Hub and Router Signal Switching

RHU PACKAGE  
(TOP VIEW)

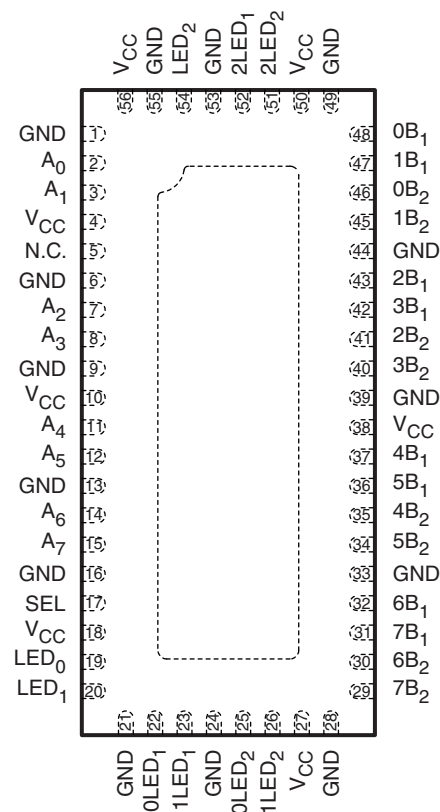

N.C. – Not internally connected



Please be aware that an important notice concerning availability, standard warranty, and use in critical applications of Texas Instruments semiconductor products and disclaimers thereto appears at the end of this data sheet.

## DESCRIPTION/ORDERING INFORMATION

The TS3L500AE is a 16-bit to 8-bit multiplexer/demultiplexer LAN switch with a single select (SEL) input. SEL controls the data path of the multiplexer/demultiplexer. The device provides additional I/Os for switching status indicating LED signals and includes high ESD protection.

The device provides a low and flat ON-state resistance ( $r_{on}$ ) and an excellent ON-state resistance match. Low input/output capacitance, high bandwidth, low skew, and low crosstalk among channels make this device suitable for various LAN applications, such as 10/100/1000 Base-T.

This device can be used to replace mechanical relays in LAN applications. It also can be used to route signals from a 10/100 Base-T ethernet transceiver to the RJ-45 LAN connectors in laptops or in docking stations.

## ORDERING INFORMATION

| $T_A$         | PACKAGE <sup>(1), (2)</sup> |               | ORDERABLE PART NUMBER | TOP-SIDE MARKING |
|---------------|-----------------------------|---------------|-----------------------|------------------|
| –40°C to 85°C | TQFN – RHU                  | Tape and reel | TS3L500AERHUR         | TK500AE          |

- (1) Package drawings, thermal data, and symbolization are available at [www.ti.com/packaging](http://www.ti.com/packaging).  
 (2) For the most current package and ordering information, see the Package Option Addendum at the end of this document, or see the TI website at [www.ti.com](http://www.ti.com).

## FUNCTION TABLE

| INPUT SEL | INPUT/OUTPUT $A_n$ | FUNCTION                        |
|-----------|--------------------|---------------------------------|
| L         | $nB_1$             | $A_n = nB_1$ , $LED_x = XLED_1$ |
| H         | $nB_2$             | $A_n = nB_2$ , $LED_x = XLED_2$ |

## PIN DESCRIPTION

| NAME     | DESCRIPTION  |
|----------|--------------|
| $A_n$    | Data I/Os    |
| $nB_m$   | Data I/Os    |
| SEL      | Select input |
| $LED_x$  | LED I/O port |
| $XLED_m$ | LED I/O port |

**LOGIC DIAGRAM (POSITIVE LOGIC)**

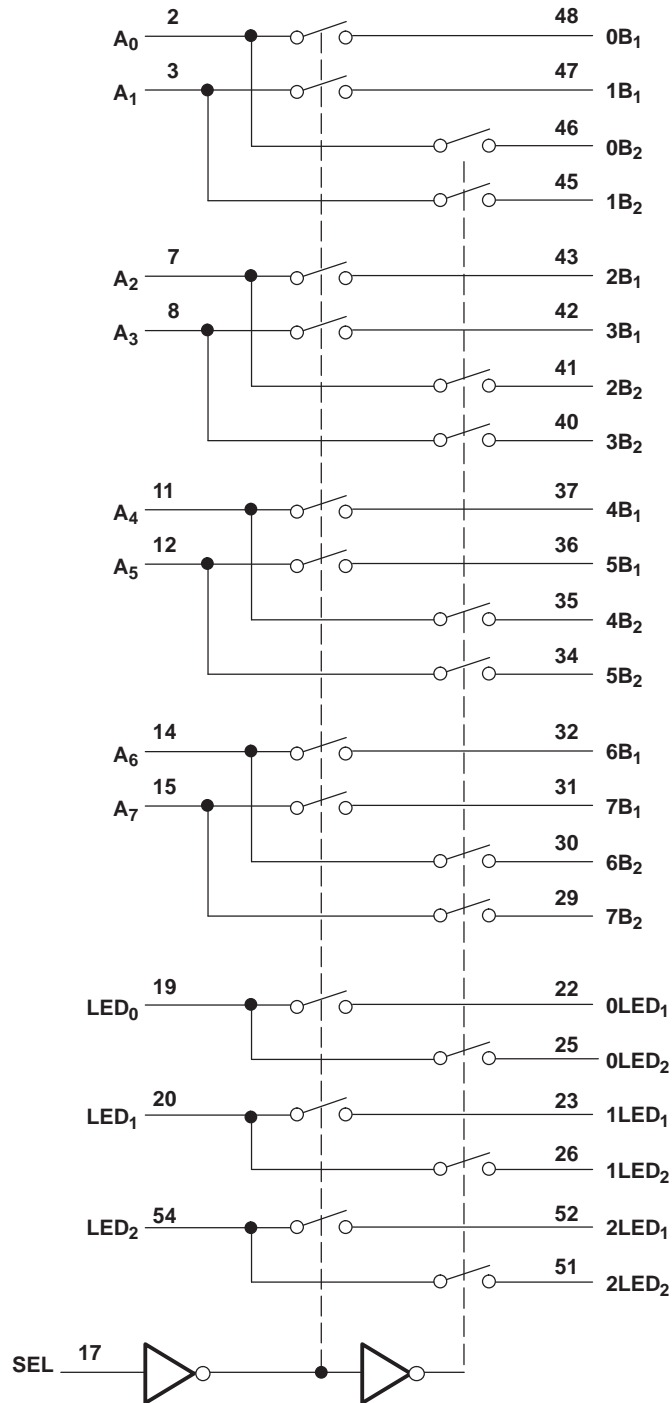

**ABSOLUTE MAXIMUM RATINGS<sup>(1)</sup>**

over operating free-air temperature range (unless otherwise noted)

|               |   | MIN           | MAX  | UNIT |
|---------------|---|---------------|------|------|
| $V_{CC}$      | Supply voltage range                          | -0.5          | 4.6  | V    |
| $V_{IN}$      | Control input voltage range <sup>(2)(3)</sup> | -0.5          | 7    | V    |
| $V_{I/O}$     | Switch I/O voltage range <sup>(2)(3)(4)</sup> | -0.5          | 7    | V    |
| $I_{IK}$      | Control input clamp current                   | $V_{IN} < 0$  | -50  | mA   |
| $I_{I/OK}$    | I/O port clamp current                        | $V_{I/O} < 0$ | -50  | mA   |
| $I_{I/O}$     | ON-state switch current <sup>(5)</sup>        |               | ±128 | mA   |
|               | Continuous current through $V_{DD}$ or GND    |               | ±100 | mA   |
| $\theta_{JA}$ | Package thermal impedance <sup>(6)</sup>      |               | 31.8 | °C/W |
| $T_{stg}$     | Storage temperature range                     | -65           | 150  | °C   |

- (1) Stresses beyond those listed under "absolute maximum ratings" may cause permanent damage to the device. These are stress ratings only, and functional operation of the device at these or any other conditions beyond those indicated under "recommended operating conditions" is not implied. Exposure to absolute-maximum-rated conditions for extended periods may affect device reliability.
- (2) All voltages are with respect to ground, unless otherwise specified.
- (3) The input and output voltage ratings may be exceeded if the input and output clamp-current ratings are observed.
- (4)  $V_I$  and  $V_O$  are used to denote specific conditions for  $V_{I/O}$ .
- (5)  $I_I$  and  $I_O$  are used to denote specific conditions for  $I_{I/O}$ .
- (6) The package thermal impedance is calculated in accordance with JESD 51-7.

**RECOMMENDED OPERATING CONDITIONS<sup>(1)</sup>**

|           |  | MIN | MAX      | UNIT |
|-----------|--|-----|----------|------|
| $V_{CC}$  | Supply voltage                         | 3   | 3.6      | V    |
| $V_{IH}$  | High-level control input voltage (SEL) | 2   | 5.5      | V    |
| $V_{IL}$  | Low-level control input voltage (SEL)  | 0   | 0.8      | V    |
| $V_I$     | Input voltage (SEL)                    | 0   | 5.5      | V    |
| $V_{I/O}$ | Input/output voltage                   | 0   | $V_{CC}$ | V    |
| $T_A$     | Operating free-air temperature         | -40 | 85       | °C   |

- (1) All unused control inputs of the device must be held at  $V_{DD}$  or GND to ensure proper device operation. Refer to the TI application report, *Implications of Slow or Floating CMOS Inputs*, literature number SCBA004.

## ELECTRICAL CHARACTERISTICS

for 1000 Base-T Ethernet switching over recommended operating free-air temperature range,  $V_{DD} = 3.3 \text{ V} \pm 0.3 \text{ V}$   
(unless otherwise noted)

| PARAMETER                            |        | TEST CONDITIONS <sup>(1)</sup> |  | MIN                    | TYP <sup>(2)</sup> | MAX     | UNIT          |
|--------------------------------------|--------|--------------------------------|--|------------------------|--------------------|---------|---------------|
| $V_{IK}$                             | SEL    | $V_{CC} = 3.6 \text{ V}$ ,     | $I_{IN} = -18 \text{ mA}$              | -0.7                   | -1.2               |         | V             |
| $I_{IH}$                             | SEL    | $V_{CC} = 3.6 \text{ V}$ ,     | $V_{IN} = V_{DD}$                      |                        |                    | $\pm 1$ | $\mu\text{A}$ |
| $I_{IL}$                             | SEL    | $V_{CC} = 3.6 \text{ V}$ ,     | $V_{IN} = \text{GND}$                  |                        |                    | $\pm 1$ | $\mu\text{A}$ |
| $I_{OFF}$                            | SEL    | $V_{CC} = 0 \text{ V}$ ,       | $V_{IN} = 0 \text{ to } 3.6 \text{ V}$ |                        |                    | $\pm 1$ | $\mu\text{A}$ |
| $I_{CC}$                             |        | $V_{CC} = 3.6 \text{ V}$ ,     | $I_{I/O} = 0$ ,                        | Switch ON or OFF       |                    | 250 600 | $\mu\text{A}$ |
| $C_{IN}$                             | SEL    | $f = 1 \text{ MHz}$ ,          | $V_{IN} = 0$                           |                        | 2 2.5              |         | pF            |
| $C_{OFF}$                            | B port | $V_I = 0$ ,                    | $f = 1 \text{ MHz}$ ,                  | Outputs open,          | Switch OFF         | 3 4     | pF            |
| $C_{ON}$                             |        | $V_I = 0$ ,                    | $f = 1 \text{ MHz}$ ,                  | Outputs open,          | Switch ON          | 9 9.8   | pF            |
| $r_{on}$                             |        | $V_{CC} = 3 \text{ V}$ ,       | $1.5 \text{ V} \leq V_I \leq V_{CC}$ , | $I_O = -40 \text{ mA}$ |                    | 4 8     | $\Omega$      |
| $r_{on(\text{flat})}$ <sup>(3)</sup> |        | $V_{CC} = 3 \text{ V}$ ,       | $V_I = 1.5 \text{ V}$ and $V_{CC}$ ,   | $I_O = -40 \text{ mA}$ |                    | 0.7     | $\Omega$      |
| $\Delta r_{on}$ <sup>(4)</sup>       |        | $V_{CC} = 3 \text{ V}$ ,       | $1.5 \text{ V} \leq V_I \leq V_{CC}$ , | $I_O = -40 \text{ mA}$ |                    | 0.2 1.2 | $\Omega$      |

- (1)  $V_I$ ,  $V_O$ ,  $I_I$ , and  $I_O$  refer to I/O pins.  $V_{IN}$  refers to the control inputs.  
 (2) All typical values are at  $V_{DD} = 3.3 \text{ V}$  (unless otherwise noted),  $T_A = 25^\circ\text{C}$ .  
 (3)  $r_{on(\text{flat})}$  is the difference of  $r_{on}$  in a given channel at specified voltages.  
 (4)  $\Delta r_{on}$  is the difference of  $r_{on}$  from center ( $A_4$ ,  $A_5$ ) ports to any other port.

## ELECTRICAL CHARACTERISTICS

for 10/100 Base-T Ethernet switching over recommended operating free-air temperature range,  $V_{DD} = 3.3 \text{ V} \pm 0.3 \text{ V}$   
(unless otherwise noted)

| PARAMETER                            |        | TEST CONDITIONS <sup>(1)</sup> |   | MIN                                       | TYP <sup>(2)</sup> | MAX     | UNIT          |
|--------------------------------------|--------|--------------------------------|---|---|--------------------|---------|---------------|
| $V_{IK}$                             | SEL    | $V_{CC} = 3.6 \text{ V}$ ,     | $I_{IN} = -18 \text{ mA}$               | -0.7                                      | -1.2               |         | V             |
| $I_{IH}$                             | SEL    | $V_{CC} = 3.6 \text{ V}$ ,     | $V_{IN} = V_{DD}$                       |   |                    | $\pm 1$ | $\mu\text{A}$ |
| $I_{IL}$                             | SEL    | $V_{CC} = 3.6 \text{ V}$ ,     | $V_{IN} = \text{GND}$                   |   |                    | $\pm 1$ | $\mu\text{A}$ |
| $I_{OFF}$                            | SEL    | $V_{CC} = 0 \text{ V}$ ,       | $V_{IN} = 0 \text{ to } 3.6 \text{ V}$  |   |                    | $\pm 1$ | $\mu\text{A}$ |
| $I_{CC}$                             |        | $V_{CC} = 3.6 \text{ V}$ ,     | $I_{I/O} = 0$ ,                         | Switch ON or OFF                          |                    | 250 600 | $\mu\text{A}$ |
| $C_{IN}$                             | SEL    | $f = 1 \text{ MHz}$ ,          | $V_{IN} = 0$                            |   | 2 2.5              |         | pF            |
| $C_{OFF}$                            | B port | $V_I = 0$ ,                    | $f = 1 \text{ MHz}$ ,                   | Outputs open,                             | Switch OFF         | 3 4     | pF            |
| $C_{ON}$                             |        | $V_I = 0$ ,                    | $f = 1 \text{ MHz}$ ,                   | Outputs open,                             | Switch ON          | 9 9.8   | pF            |
| $r_{on}$                             |        | $V_{CC} = 3 \text{ V}$ ,       | $1.25 \text{ V} \leq V_I \leq V_{CC}$ , | $I_O = -10 \text{ mA to } -30 \text{ mA}$ |                    | 4 6     | $\Omega$      |
| $r_{on(\text{flat})}$ <sup>(3)</sup> |        | $V_{CC} = 3 \text{ V}$ ,       | $V_I = 1.25 \text{ V}$ and $V_{CC}$ ,   | $I_O = -10 \text{ mA to } -30 \text{ mA}$ |                    | 0.5     | $\Omega$      |
| $\Delta r_{on}$ <sup>(4)</sup>       |        | $V_{CC} = 3 \text{ V}$ ,       | $1.25 \text{ V} \leq V_I \leq V_{CC}$ , | $I_O = -10 \text{ mA to } -30 \text{ mA}$ |                    | 0.4 1   | $\Omega$      |

- (1)  $V_I$ ,  $V_O$ ,  $I_I$ , and  $I_O$  refer to I/O pins.  $V_{IN}$  refers to the control inputs.  
 (2) All typical values are at  $V_{DD} = 3.3 \text{ V}$  (unless otherwise noted),  $T_A = 25^\circ\text{C}$ .  
 (3)  $r_{on(\text{flat})}$  is the difference of  $r_{on}$  in a given channel at specified voltages.  
 (4)  $\Delta r_{on}$  is the difference of  $r_{on}$  from center ( $A_4$ ,  $A_5$ ) ports to any other port.

## SWITCHING CHARACTERISTICS

over recommended operating free-air temperature range,  $V_{DD} = 3.3 \text{ V} \pm 0.3 \text{ V}$ ,  $R_L = 200 \ \Omega$ ,  $C_L = 10 \text{ pF}$   
(unless otherwise noted) (see Figures 4 and 5)

| PARAMETER                  | FROM<br>(INPUT) | TO<br>(OUTPUT) | MIN | TYP <sup>(1)</sup> | MAX | UNIT |
|----------------------------|-----------------|----------------|-----|--------------------|-----|------|
| $t_{pd}$ <sup>(2)</sup>    | A or B          | B or A         |     | 0.25               |     | ns   |
| $t_{PZH}$ , $t_{PZL}$      | SEL             | A or B         | 0.5 |                    | 15  | ns   |
| $t_{PHZ}$ , $t_{PLZ}$      | SEL             | A or B         | 0.9 |                    | 9   | ns   |
| $t_{sk(o)}$ <sup>(3)</sup> | A or B          | B or A         |     | 50                 | 100 | ps   |
| $t_{sk(p)}$ <sup>(4)</sup> |                 |                |     | 50                 | 100 | ps   |

- (1) All typical values are at  $V_{DD} = 3.3 \text{ V}$  (unless otherwise noted),  $T_A = 25^\circ\text{C}$ .
- (2) The propagation delay is the calculated RC time constant of the typical ON-state resistance of the switch and the specified load capacitance when driven by an ideal voltage source (zero output impedance).
- (3) Output skew between center port ( $A_4$  to  $A_5$ ) to any other port
- (4) Skew between opposite transitions of the same output in a given device  $|t_{PHL} - t_{PLH}|$

## DYNAMIC CHARACTERISTICS

over recommended operating free-air temperature range,  $V_{DD} = 3.3 \text{ V} \pm 0.3 \text{ V}$  (unless otherwise noted)

| PARAMETER  | TEST CONDITIONS        |                         |              | TYP <sup>(1)</sup> | UNIT |
|------------|------------------------|-------------------------|--------------|--------------------|------|
| $X_{TALK}$ | $R_L = 100 \ \Omega$ , | $f = 250 \text{ MHz}$ , | See Figure 8 | -37                | dB   |
| $O_{IRR}$  | $R_L = 100 \ \Omega$ , | $f = 250 \text{ MHz}$ , | See Figure 9 | -37                | dB   |
| BW         | $R_L = 100 \ \Omega$ , | See Figure 7            |              | 950                | MHz  |

- (1) All typical values are at  $V_{CC} = 3.3 \text{ V}$  (unless otherwise noted),  $T_A = 25^\circ\text{C}$ .

OPERATING CHARACTERISTICS

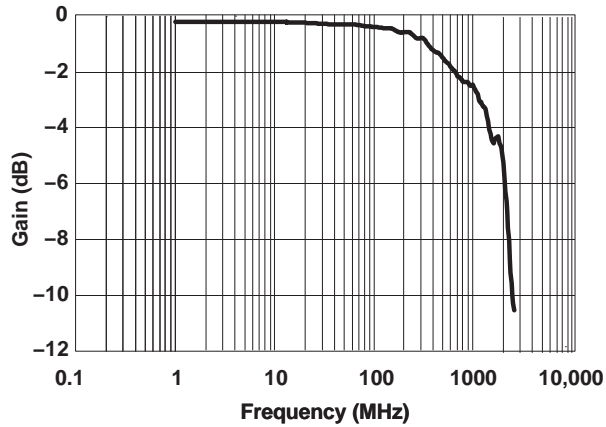

Figure 1. Gain vs Frequency

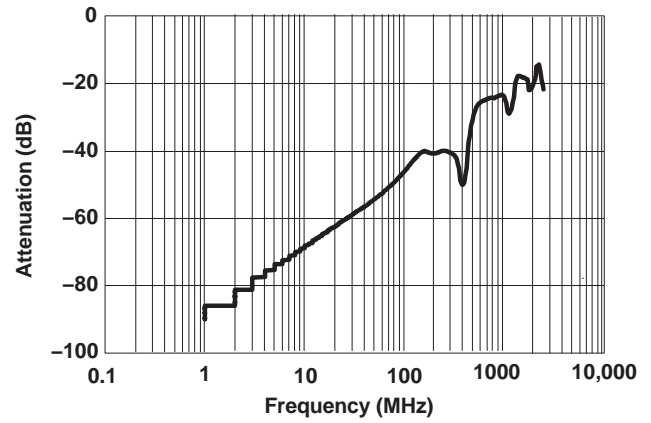

Figure 2. OFF Isolation vs Frequency

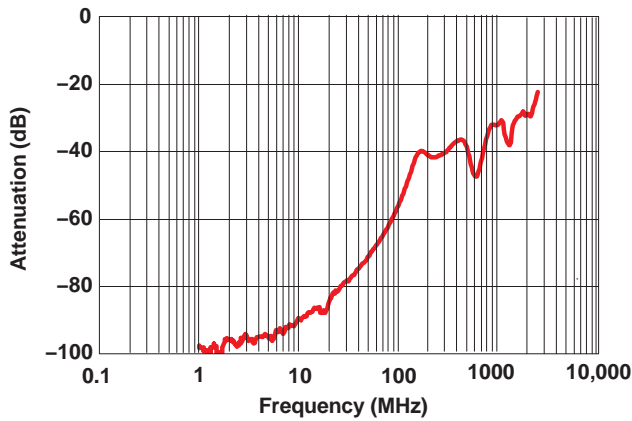

Figure 3. Crosstalk vs Frequency

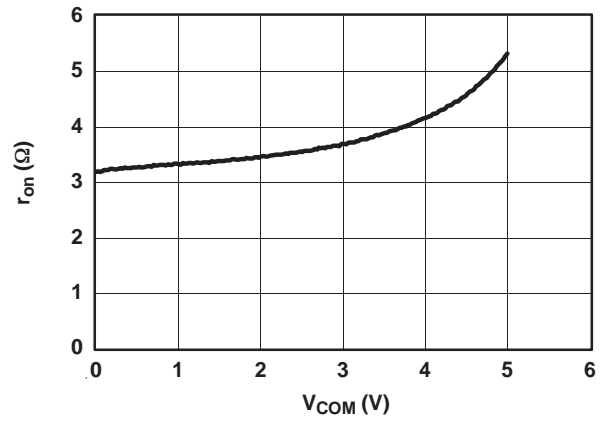
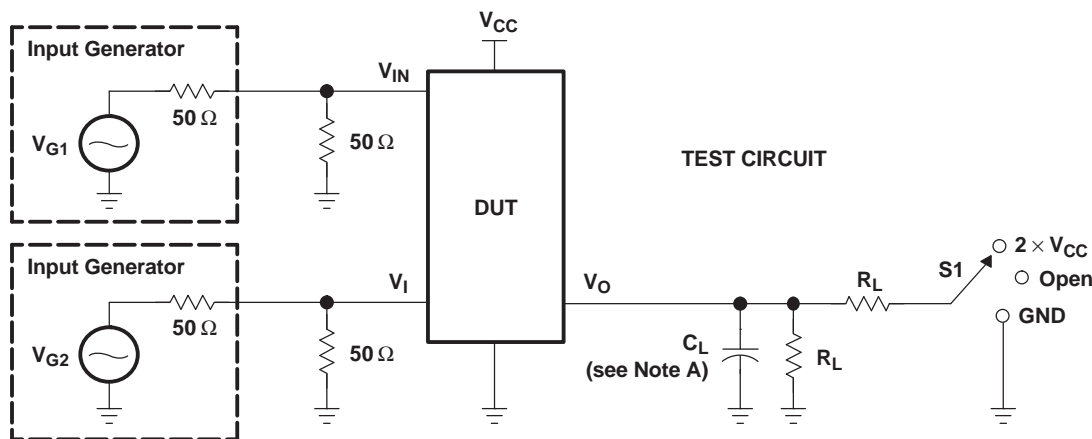
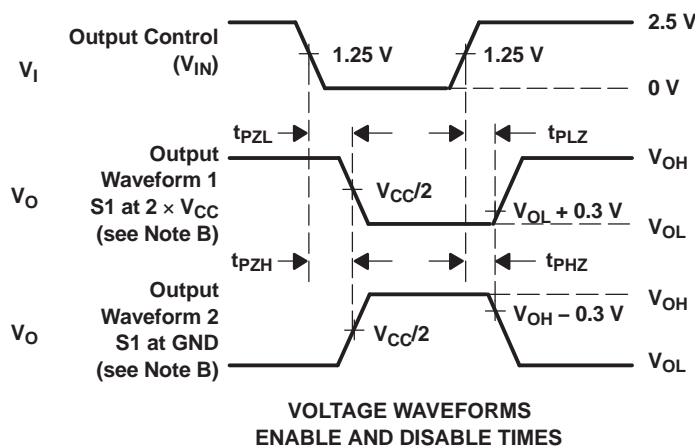

Figure 4. r<sub>on</sub> (Ω) vs V<sub>com</sub> (V)

### PARAMETER MEASUREMENT INFORMATION (Enable and Disable Times)



| TEST                               | V <sub>CC</sub> | S1                  | R <sub>L</sub> | V <sub>in</sub> | C <sub>L</sub> | V <sub>Δ</sub> |
|------------------------------------|-----------------|---------------------|----------------|-----------------|----------------|----------------|
| t <sub>PLZ</sub> /t <sub>PZL</sub> | 3.3 V ± 0.3 V   | 2 × V <sub>CC</sub> | 200 Ω          | GND             | 10 pF          | 0.3 V          |
| t <sub>PHZ</sub> /t <sub>PZH</sub> | 3.3 V ± 0.3 V   | GND                 | 200 Ω          | V <sub>CC</sub> | 10 pF          | 0.3 V          |



- NOTES: A. C<sub>L</sub> includes probe and jig capacitance.  
 B. Waveform 1 is for an output with internal conditions such that the output is low, except when disabled by the output control. Waveform 2 is for an output with internal conditions such that the output is high, except when disabled by the output control.  
 C. All input pulses are supplied by generators having the following characteristics: PRR ≤ 10 MHz, Z<sub>O</sub> = 50 Ω, t<sub>r</sub> ≤ 2.5 ns, t<sub>f</sub> ≤ 2.5 ns.  
 D. The outputs are measured one at a time, with one transition per measurement.  
 E. t<sub>PLZ</sub> and t<sub>PHZ</sub> are the same as t<sub>dis</sub>.  
 F. t<sub>PZL</sub> and t<sub>PZH</sub> are the same as t<sub>en</sub>.

Figure 5. Test Circuit and Voltage Waveforms



PARAMETER MEASUREMENT INFORMATION  
(Skew)

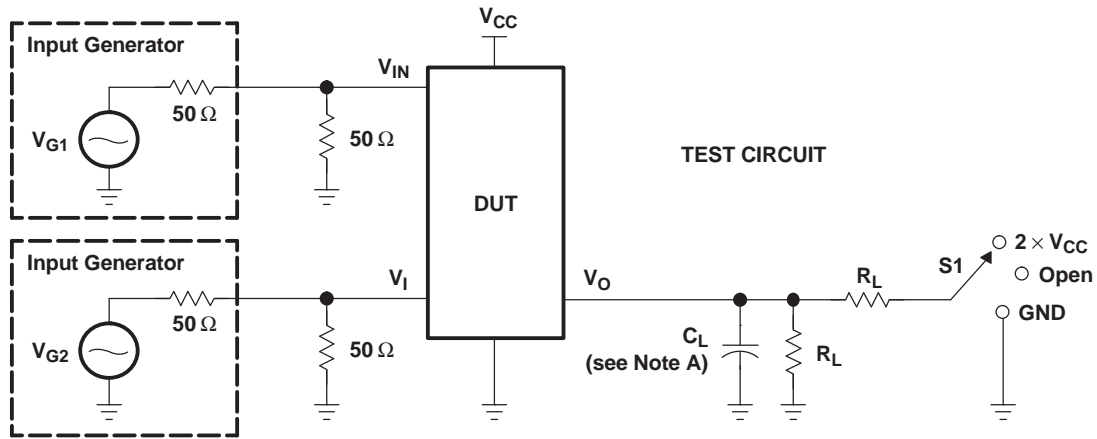

| TEST               | V <sub>CC</sub> | S1   | R <sub>L</sub> | V <sub>in</sub>        | C <sub>L</sub> |
|--------------------|-----------------|------|----------------|------------------------|----------------|
| t <sub>sk(o)</sub> | 3.3 V ± 0.3 V   | Open | 200 Ω          | V <sub>CC</sub> or GND | 10 pF          |
| t <sub>sk(p)</sub> | 3.3 V ± 0.3 V   | Open | 200 Ω          | V <sub>CC</sub> or GND | 10 pF          |

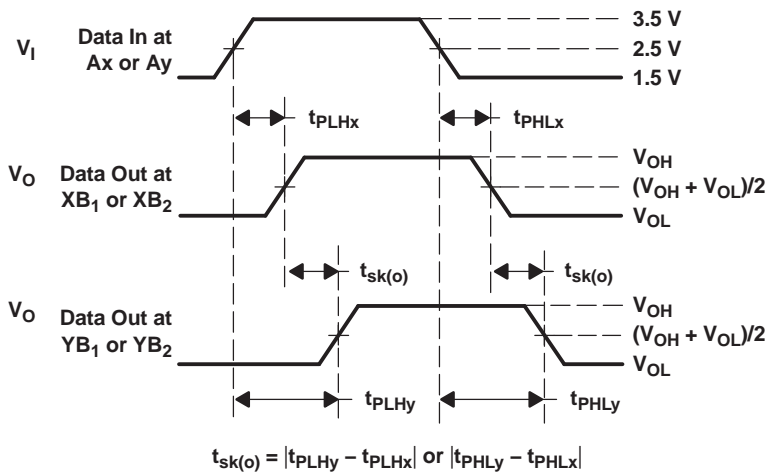

VOLTAGE WAVEFORMS  
OUTPUT SKEW [t<sub>sk(o)</sub>]

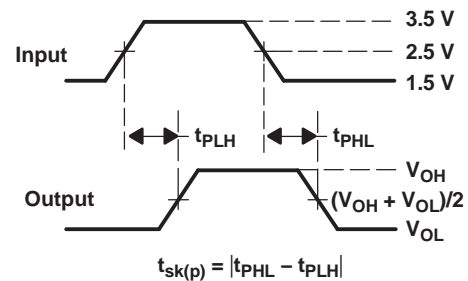

VOLTAGE WAVEFORMS  
PULSE SKEW [t<sub>sk(p)</sub>]

- NOTES: A. C<sub>L</sub> includes probe and jig capacitance.  
 B. Waveform 1 is for an output with internal conditions such that the output is low, except when disabled by the output control. Waveform 2 is for an output with internal conditions such that the output is high, except when disabled by the output control.  
 C. All input pulses are supplied by generators having the following characteristics: PRR ≤ 10 MHz, Z<sub>O</sub> = 50 Ω, t<sub>r</sub> ≤ 2.5 ns, t<sub>f</sub> ≤ 2.5 ns.  
 D. The outputs are measured one at a time, with one transition per measurement.

Figure 6. Test Circuit and Voltage Waveforms

## PARAMETER MEASUREMENT INFORMATION

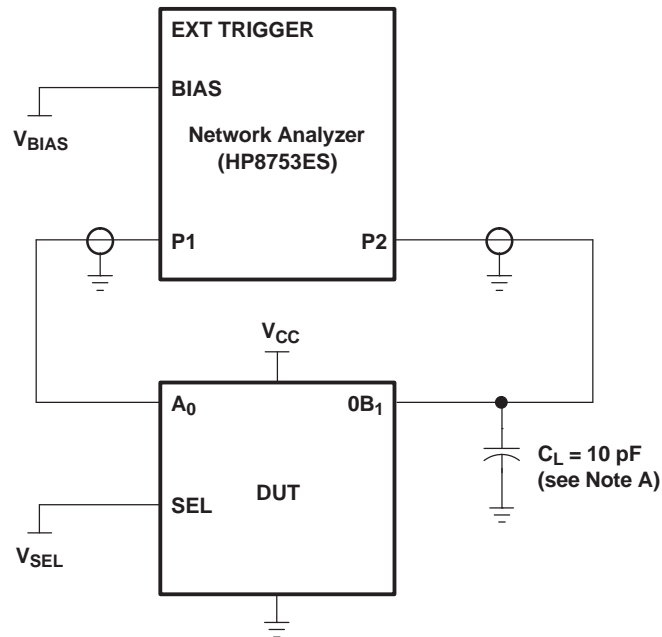

A. C<sub>L</sub> includes probe and jig capacitance.

**Figure 7. Test Circuit for Frequency Response (BW)**

Frequency response is measured at the output of the ON channel. For example, when V<sub>SEL</sub> = 0 and A<sub>0</sub> is the input, the output is measured at 0B<sub>1</sub>. All unused analog I/O ports are left open.

### HP8753ES Setup

Average = 4  
 RBW = 3 kHz  
 V<sub>BIAS</sub> = 0.35 V  
 ST = 2 s  
 P1 = 0 dBm

PARAMETER MEASUREMENT INFORMATION (continued)

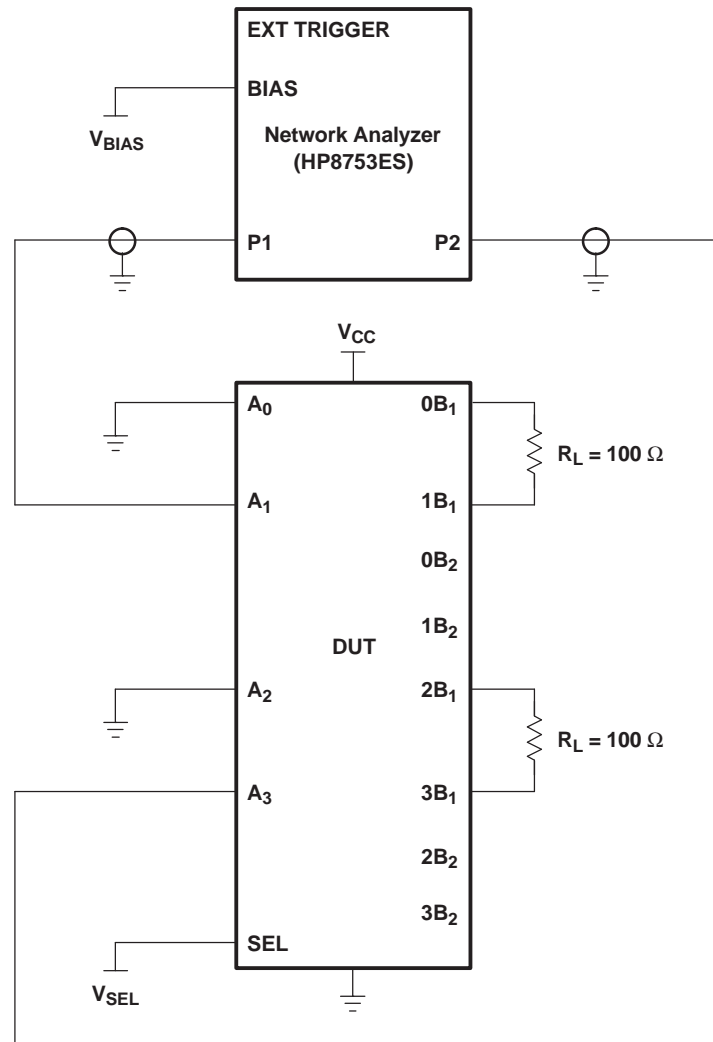

- A.  $C_L$  includes probe and jig capacitance.
- B. A 50- $\Omega$  termination resistor is needed to match the loading of the network analyzer.

**Figure 8. Test Circuit for Crosstalk ( $X_{TALK}$ )**

Crosstalk is measured at the output of the nonadjacent ON channel. For example, when  $V_{SEL} = 0$  and  $A_1$  is the input, the output is measured at  $A_3$ . All unused analog input (A) ports are connected to GND, and output (B) ports are left open.

**HP8753ES Setup**

Average = 4  
 RBW = 3 kHz  
 $V_{BIAS} = 0.35$  V  
 ST = 2 s  
 P1 = 0 dBm

## PARAMETER MEASUREMENT INFORMATION (continued)

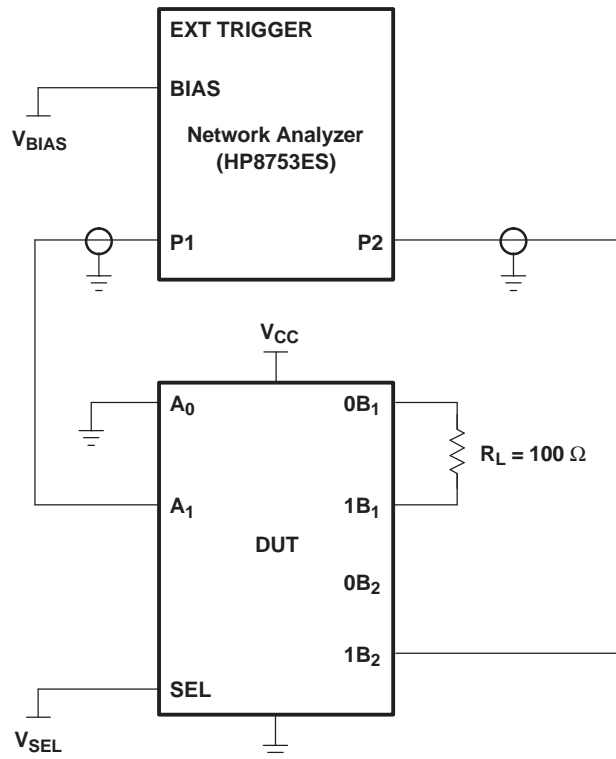

- A.  $C_L$  includes probe and jig capacitance.
- B. A 50- $\Omega$  termination resistor is needed to match the loading of the network analyzer.

**Figure 9. Test Circuit for OFF Isolation ( $O_{IRR}$ )**

OFF isolation is measured at the output of the OFF channel. For example, when  $V_{SEL} = GND$  and  $A_1$  is the input, the output is measured at  $1B_2$ . All unused analog input (A) ports are connected to ground, and output (B) ports are left open.

### HP8753ES Setup

Average = 4  
 RBW = 3 kHz  
 $V_{BIAS} = 0.35$  V  
 ST = 2 s  
 P1 = 0 dBm

**PACKAGING INFORMATION**

| Orderable Device | Status <sup>(1)</sup> | Package Type | Package Drawing | Pins | Package Qty | Eco Plan <sup>(2)</sup> | Lead/Ball Finish | MSL Peak Temp <sup>(3)</sup> | Samples<br>(Requires Login)          |
|------------------|-----------------------|--------------|-----------------|------|-------------|-------------------------|------------------|------------------------------|--------------------------------------|
| TS3L500AERHUR    | ACTIVE                | WQFN         | RHU             | 56   | 2000        | TBD                     | Call TI          | Call TI                      | <a href="#">Request Free Samples</a> |
| TS3L500AERHURG4  | ACTIVE                | WQFN         | RHU             | 56   | 2000        | TBD                     | Call TI          | Call TI                      | <a href="#">Request Free Samples</a> |

<sup>(1)</sup> The marketing status values are defined as follows:

**ACTIVE:** Product device recommended for new designs.

**LIFEBUY:** TI has announced that the device will be discontinued, and a lifetime-buy period is in effect.

**NRND:** Not recommended for new designs. Device is in production to support existing customers, but TI does not recommend using this part in a new design.

**PREVIEW:** Device has been announced but is not in production. Samples may or may not be available.

**OBSELETE:** TI has discontinued the production of the device.

<sup>(2)</sup> Eco Plan - The planned eco-friendly classification: Pb-Free (RoHS), Pb-Free (RoHS Exempt), or Green (RoHS & no Sb/Br) - please check <http://www.ti.com/productcontent> for the latest availability information and additional product content details.

**TBD:** The Pb-Free/Green conversion plan has not been defined.

**Pb-Free (RoHS):** TI's terms "Lead-Free" or "Pb-Free" mean semiconductor products that are compatible with the current RoHS requirements for all 6 substances, including the requirement that lead not exceed 0.1% by weight in homogeneous materials. Where designed to be soldered at high temperatures, TI Pb-Free products are suitable for use in specified lead-free processes.

**Pb-Free (RoHS Exempt):** This component has a RoHS exemption for either 1) lead-based flip-chip solder bumps used between the die and package, or 2) lead-based die adhesive used between the die and leadframe. The component is otherwise considered Pb-Free (RoHS compatible) as defined above.

**Green (RoHS & no Sb/Br):** TI defines "Green" to mean Pb-Free (RoHS compatible), and free of Bromine (Br) and Antimony (Sb) based flame retardants (Br or Sb do not exceed 0.1% by weight in homogeneous material)

<sup>(3)</sup> MSL, Peak Temp. -- The Moisture Sensitivity Level rating according to the JEDEC industry standard classifications, and peak solder temperature.

**Important Information and Disclaimer:** The information provided on this page represents TI's knowledge and belief as of the date that it is provided. TI bases its knowledge and belief on information provided by third parties, and makes no representation or warranty as to the accuracy of such information. Efforts are underway to better integrate information from third parties. TI has taken and continues to take reasonable steps to provide representative and accurate information but may not have conducted destructive testing or chemical analysis on incoming materials and chemicals. TI and TI suppliers consider certain information to be proprietary, and thus CAS numbers and other limited information may not be available for release.

In no event shall TI's liability arising out of such information exceed the total purchase price of the TI part(s) at issue in this document sold by TI to Customer on an annual basis.



**THERMAL INFORMATION**

This package incorporates an exposed thermal pad that is designed to be attached directly to an external heatsink. The thermal pad must be soldered directly to the printed circuit board (PCB). After soldering, the PCB can be used as a heatsink. In addition, through the use of thermal vias, the thermal pad can be attached directly to the appropriate copper plane shown in the electrical schematic for the device, or alternatively, can be attached to a special heatsink structure designed into the PCB. This design optimizes the heat transfer from the integrated circuit (IC).

For information on the Quad Flatpack No-Lead (QFN) package and its advantages, refer to Application Report, QFN/SON PCB Attachment, Texas Instruments Literature No. SLUA271. This document is available at [www.ti.com](http://www.ti.com).

The exposed thermal pad dimensions for this package are shown in the following illustration.

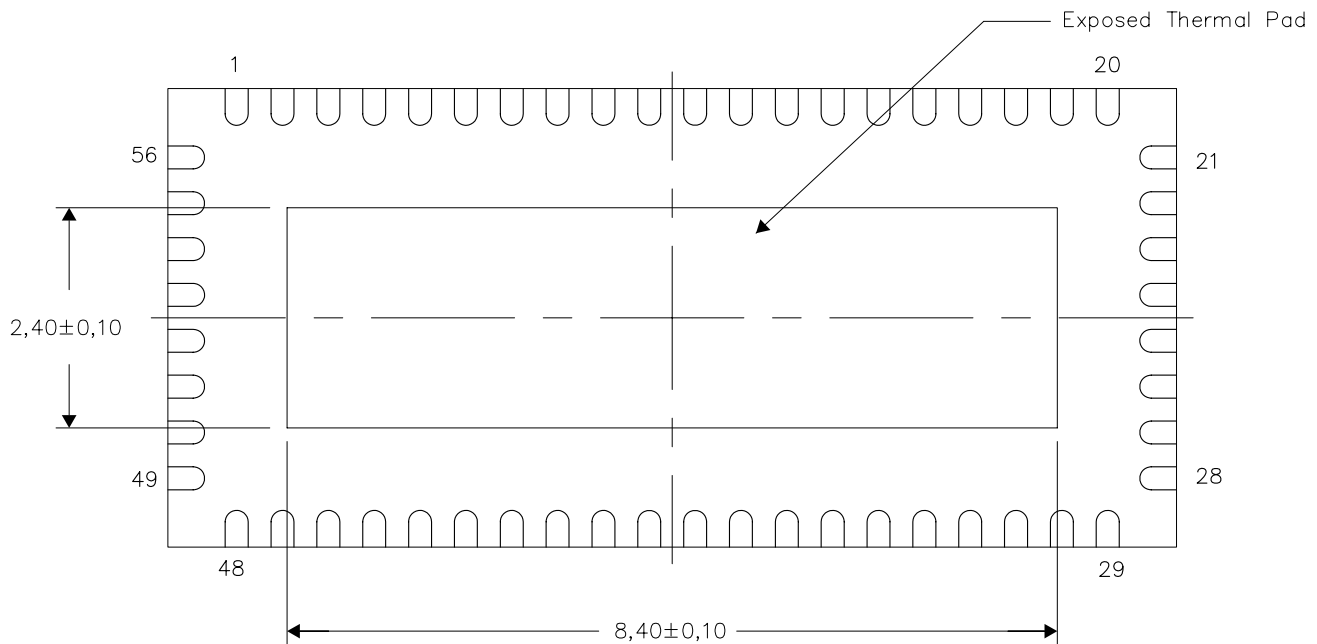

Bottom View

NOTE: All linear dimensions are in millimeters

Exposed Thermal Pad Dimensions

RHU (R-PWQFN-N56)

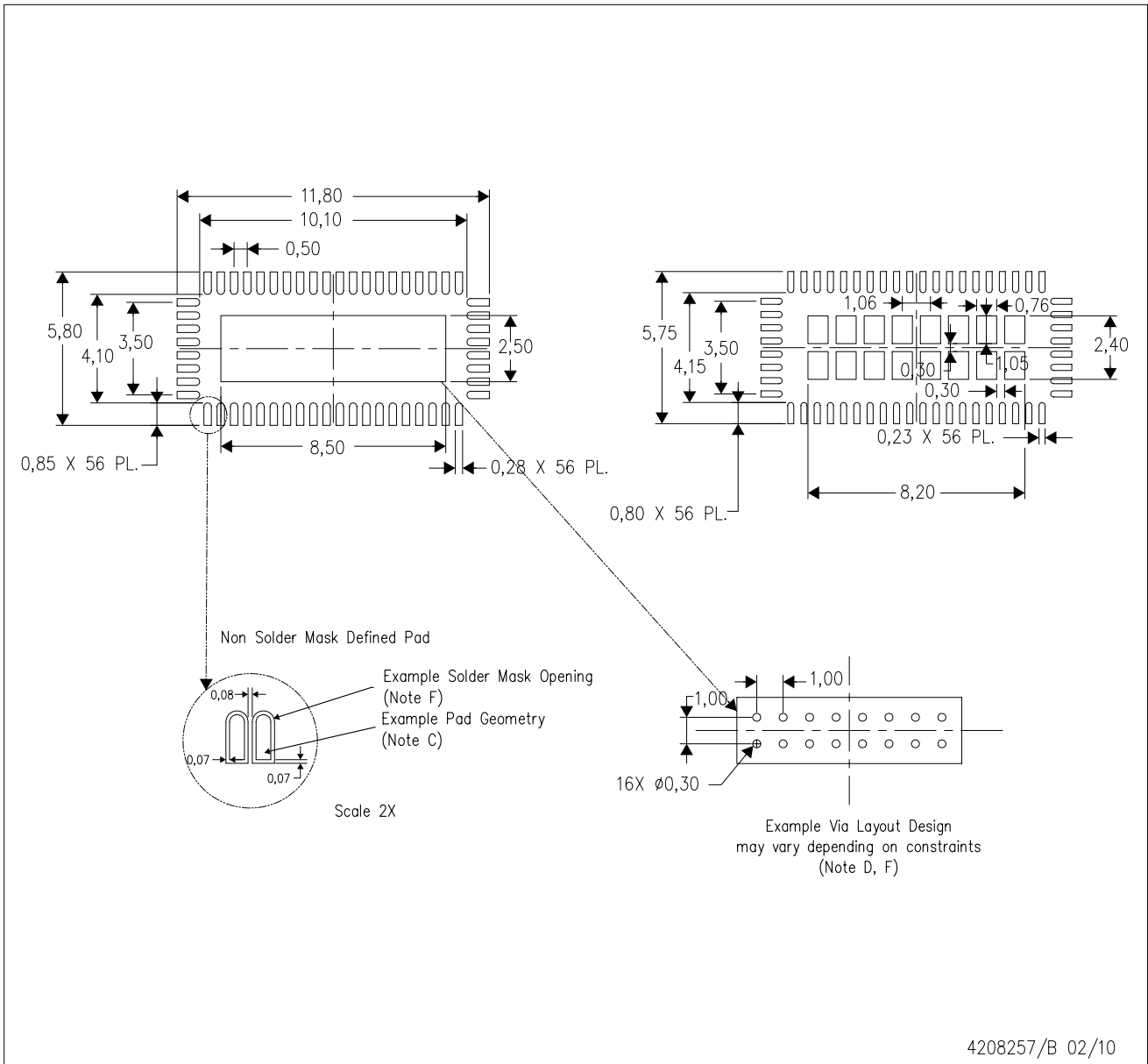

- NOTES:
- A. All linear dimensions are in millimeters.
  - B. This drawing is subject to change without notice.
  - C. Publication IPC-7351 is recommended for alternate designs.
  - D. This package is designed to be soldered to a thermal pad on the board. Refer to Application Note, Quad Flat-Pack Packages, Texas Instruments Literature No. SLUA271, and also the Product Data Sheets for specific thermal information, via requirements, and recommended board layout. These documents are available at [www.ti.com](http://www.ti.com) <<http://www.ti.com>>.
  - E. Laser cutting apertures with trapezoidal walls and also rounding corners will offer better paste release. Customers should contact their board assembly site for stencil design recommendations. Refer to IPC 7525 for stencil design considerations. Customers should contact their board fabrication site for minimum solder mask web tolerances between signal pads.



## IMPORTANT NOTICE

Texas Instruments Incorporated and its subsidiaries (TI) reserve the right to make corrections, modifications, enhancements, improvements, and other changes to its products and services at any time and to discontinue any product or service without notice. Customers should obtain the latest relevant information before placing orders and should verify that such information is current and complete. All products are sold subject to TI's terms and conditions of sale supplied at the time of order acknowledgment.

TI warrants performance of its hardware products to the specifications applicable at the time of sale in accordance with TI's standard warranty. Testing and other quality control techniques are used to the extent TI deems necessary to support this warranty. Except where mandated by government requirements, testing of all parameters of each product is not necessarily performed.

TI assumes no liability for applications assistance or customer product design. Customers are responsible for their products and applications using TI components. To minimize the risks associated with customer products and applications, customers should provide adequate design and operating safeguards.

TI does not warrant or represent that any license, either express or implied, is granted under any TI patent right, copyright, mask work right, or other TI intellectual property right relating to any combination, machine, or process in which TI products or services are used. Information published by TI regarding third-party products or services does not constitute a license from TI to use such products or services or a warranty or endorsement thereof. Use of such information may require a license from a third party under the patents or other intellectual property of the third party, or a license from TI under the patents or other intellectual property of TI.

Reproduction of TI information in TI data books or data sheets is permissible only if reproduction is without alteration and is accompanied by all associated warranties, conditions, limitations, and notices. Reproduction of this information with alteration is an unfair and deceptive business practice. TI is not responsible or liable for such altered documentation. Information of third parties may be subject to additional restrictions.

Resale of TI products or services with statements different from or beyond the parameters stated by TI for that product or service voids all express and any implied warranties for the associated TI product or service and is an unfair and deceptive business practice. TI is not responsible or liable for any such statements.

TI products are not authorized for use in safety-critical applications (such as life support) where a failure of the TI product would reasonably be expected to cause severe personal injury or death, unless officers of the parties have executed an agreement specifically governing such use. Buyers represent that they have all necessary expertise in the safety and regulatory ramifications of their applications, and acknowledge and agree that they are solely responsible for all legal, regulatory and safety-related requirements concerning their products and any use of TI products in such safety-critical applications, notwithstanding any applications-related information or support that may be provided by TI. Further, Buyers must fully indemnify TI and its representatives against any damages arising out of the use of TI products in such safety-critical applications.

TI products are neither designed nor intended for use in military/aerospace applications or environments unless the TI products are specifically designated by TI as military-grade or "enhanced plastic." Only products designated by TI as military-grade meet military specifications. Buyers acknowledge and agree that any such use of TI products which TI has not designated as military-grade is solely at the Buyer's risk, and that they are solely responsible for compliance with all legal and regulatory requirements in connection with such use.

TI products are neither designed nor intended for use in automotive applications or environments unless the specific TI products are designated by TI as compliant with ISO/TS 16949 requirements. Buyers acknowledge and agree that, if they use any non-designated products in automotive applications, TI will not be responsible for any failure to meet such requirements.

Following are URLs where you can obtain information on other Texas Instruments products and application solutions:

| <b>Products</b>             |  | <b>Applications</b>        |  |
|-----------------------------|--|----------------------------|--|
| Amplifiers                  | <a href="http://amplifier.ti.com">amplifier.ti.com</a>             | Audio                      | <a href="http://www.ti.com/audio">www.ti.com/audio</a>                                   |
| Data Converters             | <a href="http://dataconverter.ti.com">dataconverter.ti.com</a>     | Automotive                 | <a href="http://www.ti.com/automotive">www.ti.com/automotive</a>                         |
| DLP® Products               | <a href="http://www.dlp.com">www.dlp.com</a>                       | Communications and Telecom | <a href="http://www.ti.com/communications">www.ti.com/communications</a>                 |
| DSP                         | <a href="http://dsp.ti.com">dsp.ti.com</a>                         | Computers and Peripherals  | <a href="http://www.ti.com/computers">www.ti.com/computers</a>                           |
| Clocks and Timers           | <a href="http://www.ti.com/clocks">www.ti.com/clocks</a>           | Consumer Electronics       | <a href="http://www.ti.com/consumer-apps">www.ti.com/consumer-apps</a>                   |
| Interface                   | <a href="http://interface.ti.com">interface.ti.com</a>             | Energy                     | <a href="http://www.ti.com/energy">www.ti.com/energy</a>                                 |
| Logic                       | <a href="http://logic.ti.com">logic.ti.com</a>                     | Industrial                 | <a href="http://www.ti.com/industrial">www.ti.com/industrial</a>                         |
| Power Mgmt                  | <a href="http://power.ti.com">power.ti.com</a>                     | Medical                    | <a href="http://www.ti.com/medical">www.ti.com/medical</a>                               |
| Microcontrollers            | <a href="http://microcontroller.ti.com">microcontroller.ti.com</a> | Security                   | <a href="http://www.ti.com/security">www.ti.com/security</a>                             |
| RFID                        | <a href="http://www.ti-rfid.com">www.ti-rfid.com</a>               | Space, Avionics & Defense  | <a href="http://www.ti.com/space-avionics-defense">www.ti.com/space-avionics-defense</a> |
| RF/IF and ZigBee® Solutions | <a href="http://www.ti.com/lprf">www.ti.com/lprf</a>               | Video and Imaging          | <a href="http://www.ti.com/video">www.ti.com/video</a>                                   |
|                             |  | Wireless                   | <a href="http://www.ti.com/wireless-apps">www.ti.com/wireless-apps</a>                   |

Mailing Address: Texas Instruments, Post Office Box 655303, Dallas, Texas 75265  
Copyright © 2010, Texas Instruments Incorporated