

3 PIN

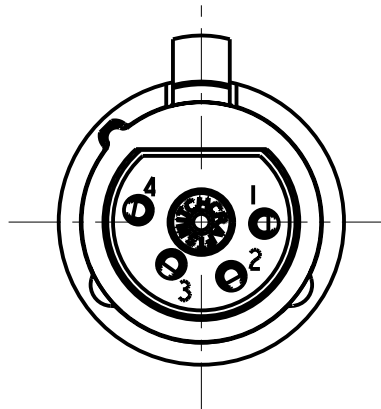

4 PIN

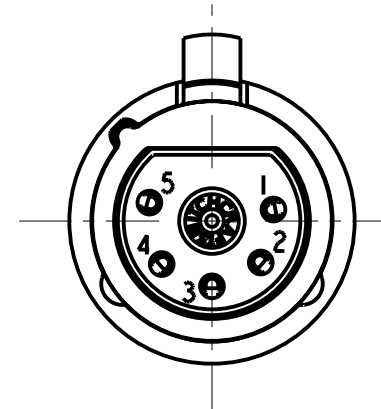

5 PIN

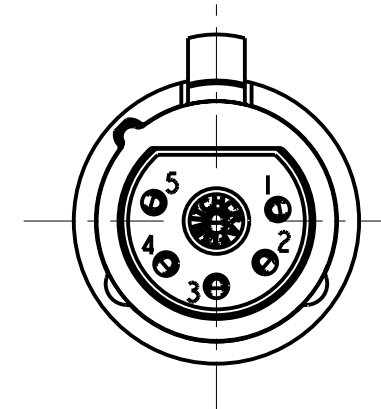

6 PIN

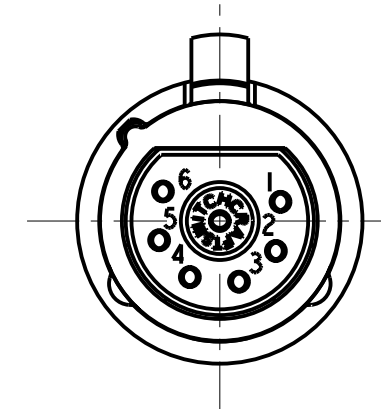

7 PIN

STANDARD SERIES

INSERT SCREW - STAINLESS STEEL
 FLEX SCREW - STEEL, NICKEL PLATED
 HOUSING - ZINC, NICKEL PLATED
 SHELL - STAINLESS STEEL
 LATCH BUTTON - ZINC, NICKEL PLATED
 LATCH SPRING - STAINLESS STEEL
 CONTACTOR - BERYLLIUM COPPER, NICKEL PLATE
 TUBULAR INSULATOR - MYLAR
 SOLDER TERMINAL - BRASS, ELECTRO TIN
 FLEX RELIEF - HI-FAX
 CLAMP PLATE - STAINLESS STEEL
 INSULATORS - POLYESTER, GREEN
 CONTACTS - BRASS, SILVER PLATED

- A COLOR OF FLEX RELIEF
 - 01 = BROWN
 - 02 = RED
 - 03 = ORANGE
 - 04 = YELLOW
 - 05 = GREEN
 - 06 = BLUE
 - 07 = VIOLET
 - 08 = GRAY
 - 09 = WHITE
 - 11 = TAN
 - 12 = PINK
 - 13 = DARK BLUE
- F CONTACT PLATING
 - BLANK = SILVER (STANDARD)
 - AU = GOLD
- HOUSING FINISH
 - BLANK = NICKEL PLATE (STANDARD)
 - B = BLACK
- LATCH TYPE
 - BLANK = STANDARD LATCHLOCK
 - D = FAS-DIS-CONNECT DETENT (SEE FIGURE 3)
- FLEX RELIEF SIZE
 - BLANK = STANDARD SIZE (0.210 TO 0.300)
 - L = LARGE CABLES (0.300 TO .0328)
 - S = SMALL CABLES (0.105 TO 0.205)
- NO. OF CONTACTS:
 - 3 = 3 CONTACTS
 - 4 = 4 CONTACTS
 - 5 = 5 CONTACTS
 - 6 = 6 CONTACTS
 - 7 = 7 CONTACTS

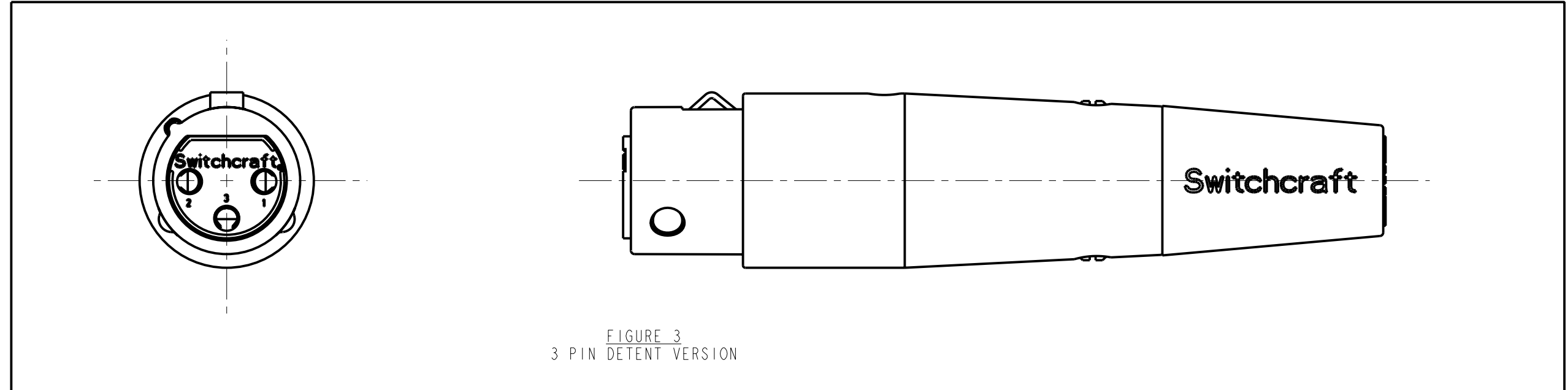
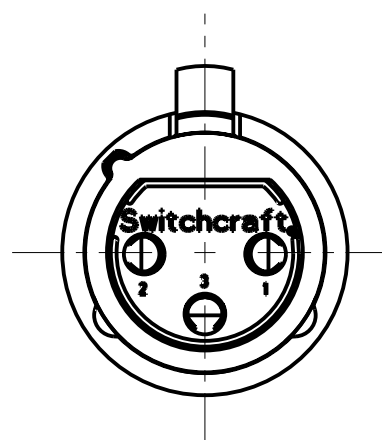
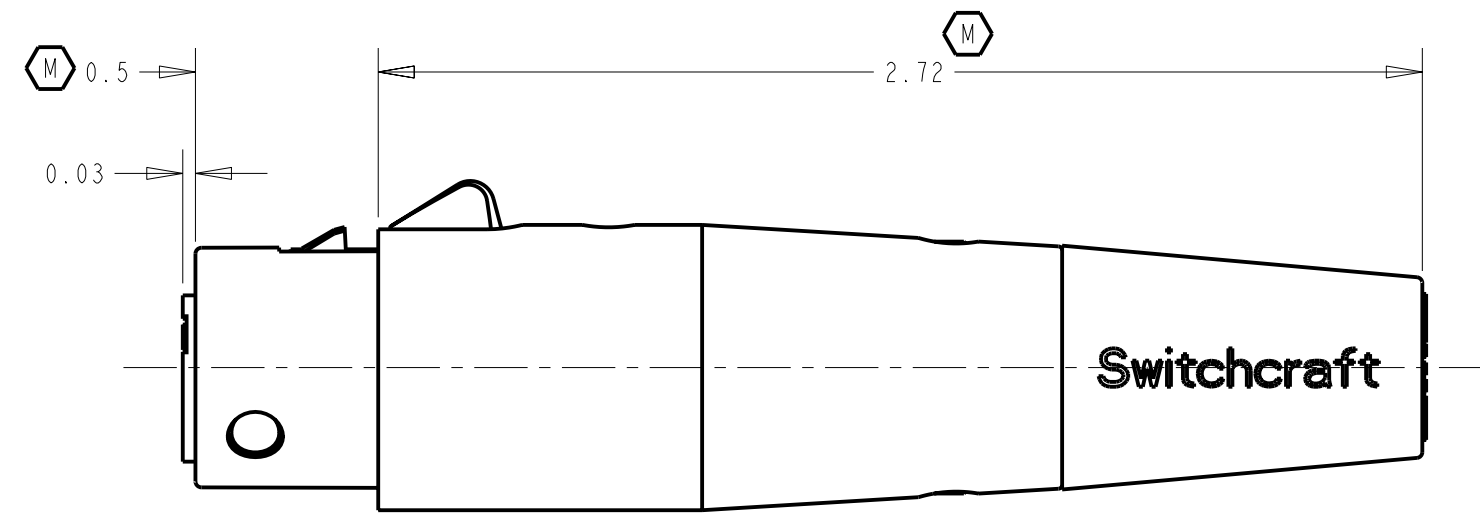
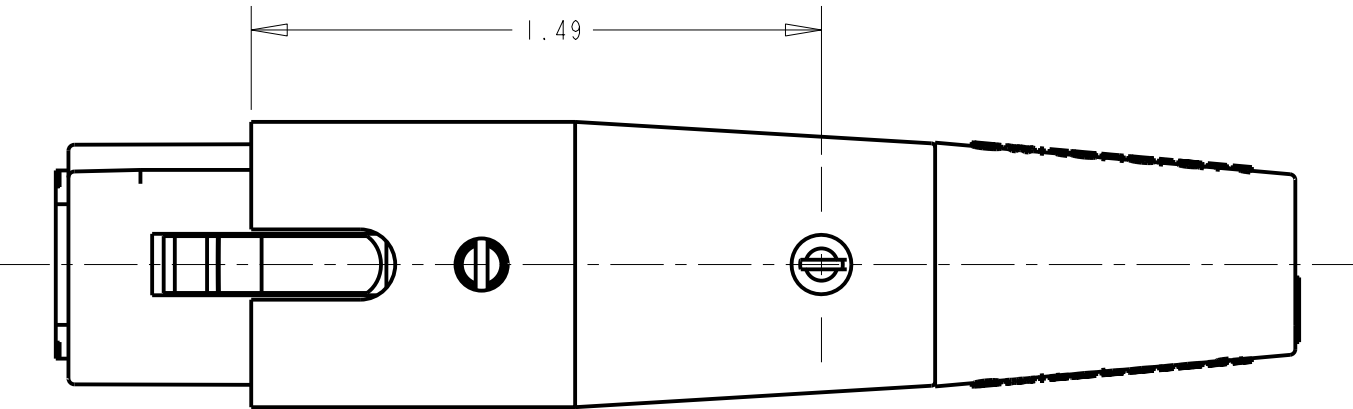

FIGURE 3
3 PIN DETENT VERSION



PROFESSIONAL SERIES

SAME AS ABOVE EXCEPT
 CONTACT PIN - PHOSPHOR BRONZE, GOLD OVER NICKEL

- OGP 22
- NO. OF CONTACTS:
 - 3 = 3 CONTACTS
 - 4 = 4 CONTACTS
 - 5 = 5 CONTACTS
 - 6 = 6 CONTACTS
 - 7 = 7 CONTACTS

NOTE:
 1. ALL DIMENSIONS REF. UNLESS OTHERWISE SPECIFIED.

CUSTOMER DRAWING

☆ STAR SYMBOL DENOTES CRITICAL DIMENSION UNLESS OTHERWISE SPECIFIED 1. ALL DIMENSIONS IN INCHES - TWO PLACE DECIMALS ±0.01 - THREE PLACE DECIMALS ±0.005 - ANGLES ±1° - ALL DIA. CONCENTRIC WITHIN 0.005 T.I.R. 2. FEATURES ON THE SAME CENTERLINE MUST BE ALIGNED WITHIN ±0.002 3. REMOVE ALL BURRS DO NOT SCALE DRAWING					THIS DRAWING DESCRIBES A DESIGN CONSIDERED PROPRIETARY IN NATURE, DEVELOPED AND MANUFACTURED BY SWITCHCRAFT INC. AND IS RELEASED ON A CONFIDENTIAL BASIS FOR IDENTIFICATION PURPOSES ONLY.				
SIZE		WIDTH		MULT		LBS/M		TEMPER	
FINISH					MATERIAL SPEC No.				
SPEC No.					SCALE 2:1				
DATE DRAWN			BY		CHKD		APVD		
10-26-93			SG		1-19-95		GHJ 1-19-95		
NAME					PART No.				
A SERIES FEMALE OGP					A_F_SERIES				
REV W					REV W				