

SD103A~SD103C

SMALL SIGNAL SCHOTTKY BARRIES SWITCHING DIODES

VOLTAGE 20 to 40 Volts **CURRENT** 0.35 Amperes

DO-35

Unit: inch (mm)

FEATURES

- Low Forward Voltage Drop
- Guard Ring Construction for Transient Protection
- Low Reverse Recovery Time
- Low Reverse Capacitance
- In compliance with EU RoHS 2002/95/EC directives

MECHANICAL DATA

- Case: Molded Glass DO-35
- Terminals: Solderable per MIL-STD-750, Method 2026
- Polarity: See Diagram Below
- Approx. Weight: 0.13 grams
- Mounting Position: Any
- Ordering information
Suffix : " -35 " to order DO-35 Package
- Packing information
B - 2K per Bulk box
T/R - 10K per 13" plastic Reel
T/B - 5K per horiz. tape & Ammo box

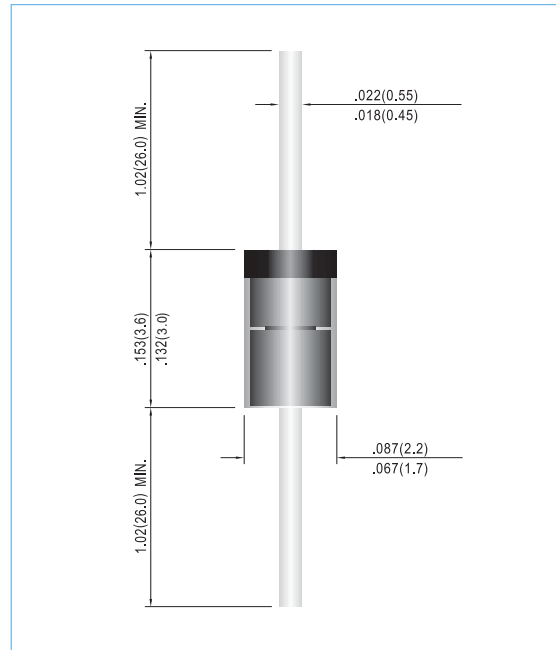

MAXIMUM RATINGS AND ELECTRICAL CHARACTERISTICS (T_J=25°C unless otherwise noted)

PARAMETER	SYMBOL	SD103A	SD103B	SD103C	UNITS
Marking Code	-	103A	103B	103C	-
Peak Repetitive Reverse Voltage	V _{RRM}	40	30	20	V
RMS Reverse Voltage	V _{RMS}	28	21	14	V
Max. Average Rectified Current	I _{F(AV)}	350			mA
Peak Forward Surge Current, t ≤ 0.3ms	I _{FSM}	15			A
Power Dissipation Derate Above 25°C	P _D	400			mW
Maximum Forward Voltage, I _F = 20mA I _F = 200mA	V _F	0.37 0.70			V
Maximum Reverse Current	I _R	5 @ 30V	5 @ 20V	5 @ 10V	μA
Typical Junction Capacitance(Note 1)	C _J	50			pF
Typical Reverse Recovery (Note 2)	t _{rr}	10			ns
Typical Thermal Resistance	R _{θJA}	250			°C / W
Storage Temperature Range	T _{STG}	-65 to +175			°C

NOTE:

1. C_J at V_R=0, f=1MHZ
2. From I_F=50mA to I_R=200mA, R_L=100Ω

SD103A~SD103C

RATING AND CHARACTERISTIC CURVES

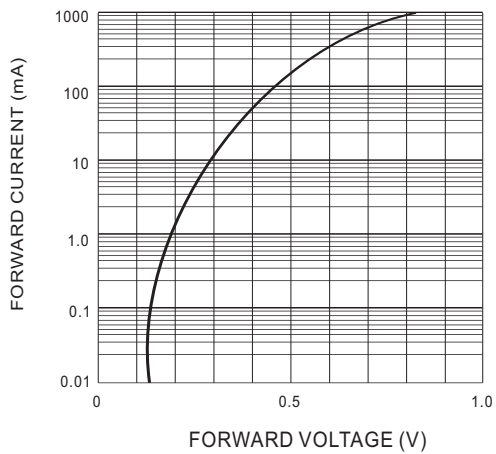

Fig. 1 FORWARD CHARACTERISTICS

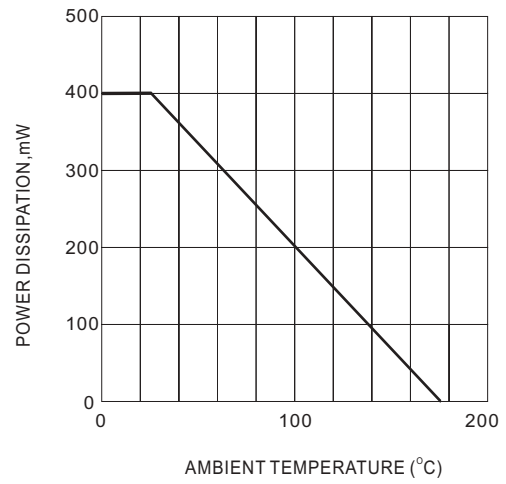

Fig. 2 POWER DISSIPATION DERATING CURVE

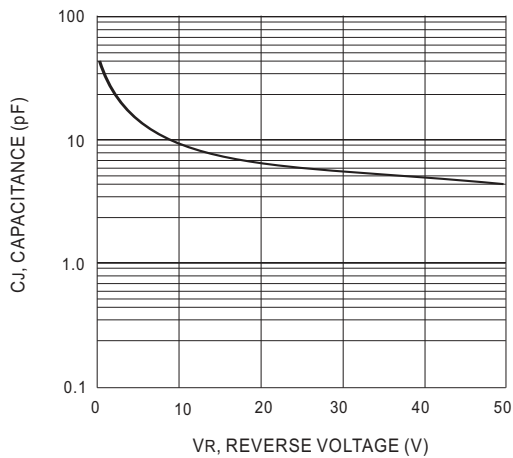

Fig. 3 TYPICAL CAPACITANCE vs REVERSE VOLTAGE