

W541C20X Data Sheet



4-BIT MICROCONTROLLER

Table of Contents-

1. GENERAL DESCRIPTION	2
2. FEATURES	2
3. BLOCK DIAGRAM	4
4. PIN CONFIGURATIONS	5
5. PIN DESCRIPTION	6
6. ELECTRICAL CHARACTERISTICS	7
6.1 Absolute Maximum Ratings	7
6.2 DC Characteristics	7
6.3 AC Characteristics	8
7. APPLICATION CIRCUIT	9
8. PACKAGE DIMENSIONS	10
8.1 18-Lead PDIP-300mil	10
8.2 20-Lead PDIP	11
8.3 28-Lead P-DIP Skinny	12
8.4 20-Lead SOP-300mil	13
8.5 28-Lead SOP-300mil	14
9. REVISION HISTORY	15



1. GENERAL DESCRIPTION

The W541C20X is fully compatible with W741C20X in the terms of pin assignment and IC function. It is a high-performance 4-bit microcontroller (μC) that operates on very low current. The device contains a 4-bit ALU, two 8-bit timers, a divider, a serial port, and five 4-bit I/O ports (including 3 output ports for LED driving). There are also seven interrupt sources and 8-level subroutine nesting for interrupt applications. The W541C20X has two power reduction modes, hold mode and stop mode, which help to minimize power dissipation.

The W541C20X is suitable for remote controllers, toy controllers, keyboard controllers, speech synthesis LSI controllers, and other products.

2. FEATURES

- Operating voltage: 2.4V to 5.5V
- Single system clock
 - Oscillation frequency up to 4 MHz, Crystal or RC oscillator is selected by mask code option
 - High-frequency (400 KHz to 4 MHz) or low-frequency (32.768 KHz) oscillation is selected by mask code option
- Memory
 - 2048 x 16 bit program ROM (including 2K x 4 bit look-up table)
 - 128 x 4 bit data RAM (including 16 working registers)
- 21 input/output pins
 - Input/output ports: 4 ports/16 pins
 - Serial input/output port: 1 port /4 pins (high sink current for LED driving)
 - MFP output pin: 1 pin (MFP)
 - Do not be floating when it is as input or output open-drain (NMOS type).
- Power-down mode
 - Hold function: no operation (except for oscillator)
 - Stop function: no operation (including oscillator)
- Seven types of interrupts
 - Five internal interrupts (Divider 0, Timer 0, Timer 1, and Serial I/O)
 - Two external interrupts (Port RC and $\overline{\text{INT}}$ pin)
- MFP output pin
 - Output is software selectable as modulating or nonmodulating frequency
 - Works as frequency output specified by Timer 1
- Built-in 14-bit clock frequency divider circuit

W541C20X



- Two built-in 8-bit programmable countdown timers
 - Timer 0: One of two internal clock frequencies ($F_{osc}/4$ or $F_{osc}/1024$) can be selected
 - Timer 1: Offers auto-reload function, and one of two internal clock frequencies (F_{osc} or $F_{osc}/64$) can be selected, or falling edge of pin RC.0 can be selected (output through MFP pin)
- Built-in 18/14-bit watchdog timer selectable for system reset
- Powerful instruction set: 118 instructions
- 8-level subroutine (include interrupt) nesting
- One serial transmission/receiver port specified by software
- Up to 1 μ S instruction cycle (with 4 MHz operating frequency)
- Packaged in 18-pin, 20-pin, 28-pin PDIP and 20-pin, 28-pin SOP

EEPW 电子产业世界
.com.cn



3. BLOCK DIAGRAM

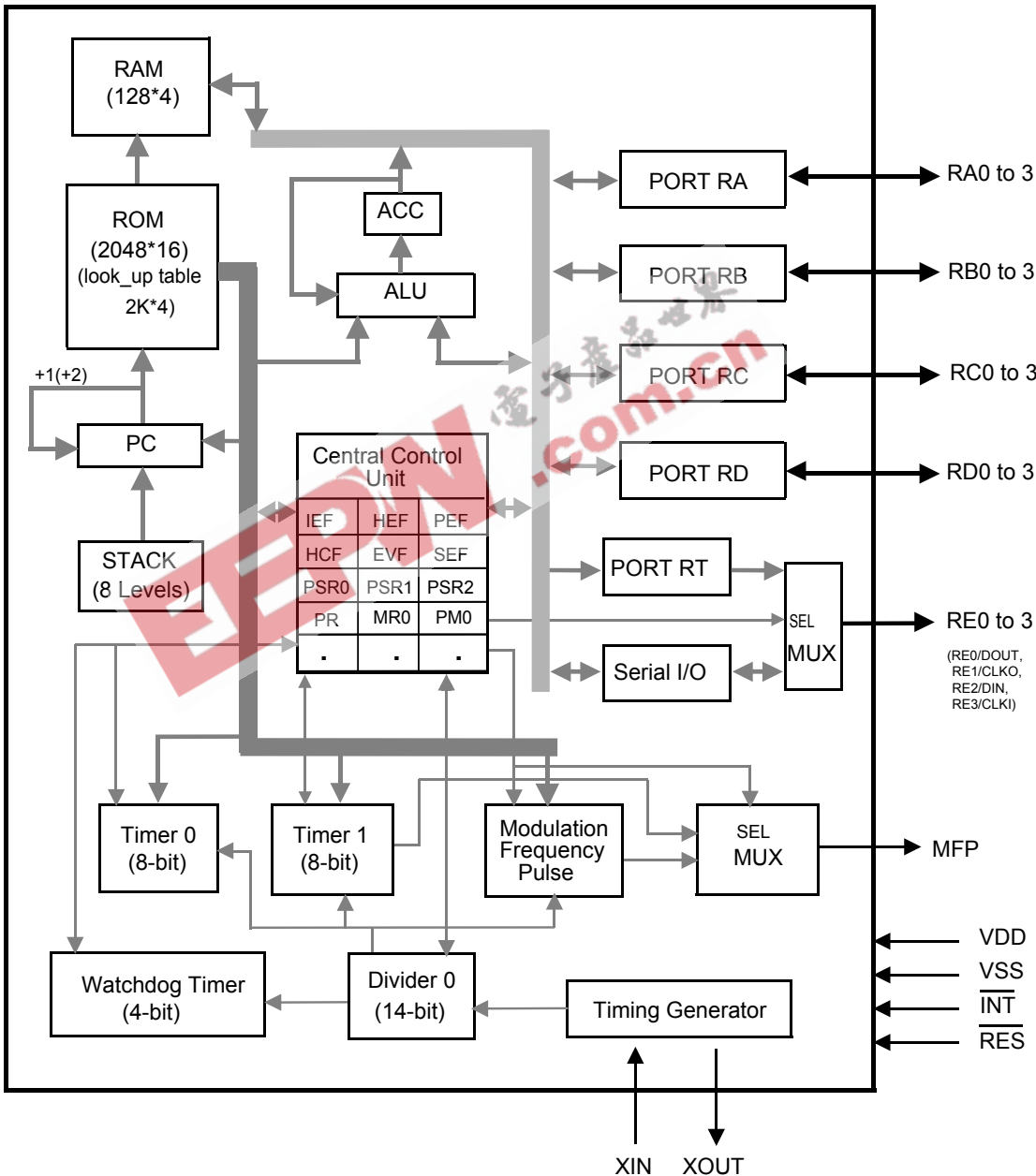

4. PIN CONFIGURATIONS

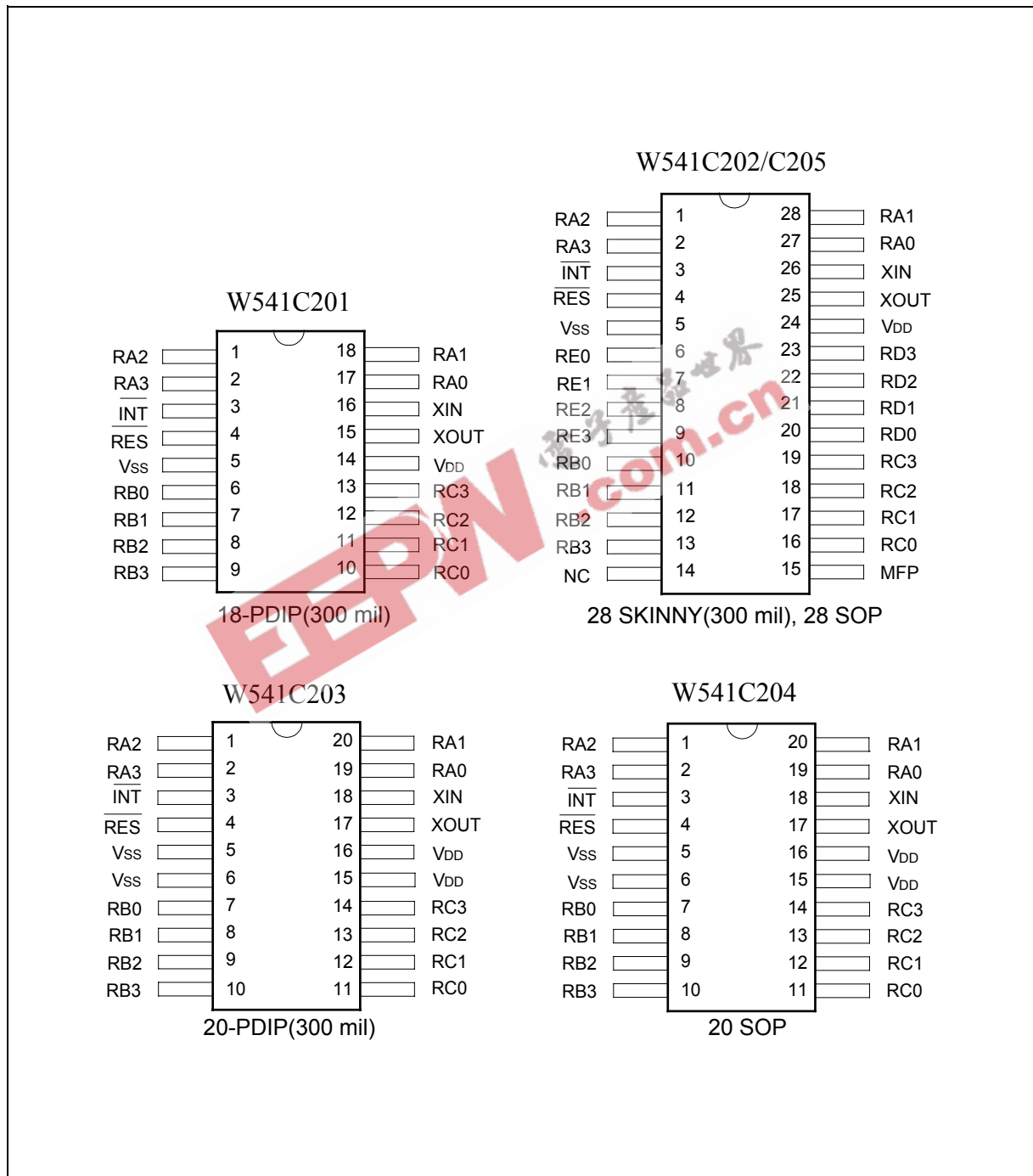



5. PIN DESCRIPTION

SYMBOL	I/O	FUNCTION
XIN	I	Input pin for oscillator. Connected to crystal or resistor to generate system clock by code option. External 10~20pF capacitor uses to get accurate freq in crystal mode.
XOUT	O	Output pin for oscillator. Connected to crystal or resistor to generate system clock by code option. 20pF capacitor is built in internal for crystal mode.
RA0~RA3	I/O	Input/Output port. Input/output mode specified by port mode 1 register (PM1). When used as output port, can provide high sink current for driving LED.
RB0~RB3	I/O	Input/Output port. Input/output mode specified by port mode 2 register (PM2). When used as output port, can provide high sink current for driving LED.
RC0~RC3	I/O	Input/Output port. Input/output mode specified by port mode 4 register (PM4). Each pin has an independent interrupt capability in input mode. And build-in schmitt trigger.
RD0~RD3	I/O	Input/Output port. Input/output mode specified by port mode 5 register (PM5).
RE0/DOUT RE1/CLKO RE2/DIN RE3/CLKI	I/O	Special input/output port. This port can be configured by software to act as the output of internal port RT or the serial I/O port. When used as output port, can provide high sink current for driving LED.
MFP	O	Output pin only. This pin can output modulating or nonmodulating frequency, or Timer 1 clock output specified by mode register 1 (MR1).
$\overline{\text{INT}}$	I	External interrupt pin with pull-high resistor.
$\overline{\text{RES}}$	I	System reset pin with pull-high resistor.
V _{DD}	I	Positive power supply (+).
V _{SS}	I	Negative power supply (-).



6. ELECTRICAL CHARACTERISTICS

6.1 Absolute Maximum Ratings

PARAMETER	RATING	UNIT
Supply Voltage to Ground Potential	-0.3 to +7.0	V
Applied Input/Output Voltage	-0.3 to +7.0	V
Power Dissipation	120	mW
Ambient Operating Temperature	0 to +70	°C
Storage Temperature	-55 to +150	°C

Note: Exposure to conditions beyond those listed under Absolute Maximum Ratings may adversely affect the life and reliability of the device.

6.2 DC Characteristics

($V_{DD}-V_{SS} = 3.0V$, $F_{osc} = 32.768\text{ KHz}$, $T_a = 25^\circ\text{ C}$; unless otherwise specified)

PARAMETER	SYM.	CONDITIONS	MIN.	TYP.	MAX.	UNIT
Op. Voltage	V_{DD}	-	2.4	-	5.5	V
Op. Current (Crystal type)	I_{OP1}	No load (Ext-V)	-	8	20	μA
Op. Current (RC type)	I_{OP2}	No load (Ext-V)	-	35	65	μA
Hold Current (Crystal type)	I_{HM1}	Hold mode No load (Ext-V)	-	4	6	μA
Hold Current (RC type)	I_{HM2}	Hold mode No load (Ext-V)	-	16	40	μA
Stop Current (Crystal type)	I_{SM1}	Stop mode No load (Ext-V)	-	0.1	2	μA
Stop Current (RC type)	I_{SM2}	Stop mode No load (Ext-V)	-	0.1	2	μA
Input Low Voltage	V_{IL}	-	V_{SS}	-	$0.3 V_{DD}$	V
Input High Voltage	V_{IH}	-	$0.7 V_{DD}$	-	V_{DD}	V
MFP Output Low Voltage	V_{ML}	$I_{OL} = 2.7\text{ mA}$	-	-	0.4	V
MFP Output High Voltage	V_{MH}	$I_{OH} = -3.5\text{ mA}$	2.4	-	-	V
Port RA, RB Sink Current	I_{ABL}	$V_{OL} = 0.9V$	7.5	-	-	mA
Port RA, RB Source Current	I_{ABH}	$V_{OH} = 2.4V$	0.4	1.2	-	mA
Port RC, RD Output Low Voltage	V_{CDL}	$I_{OL} = 2.0\text{ mA}$	-	-	0.4	V
Port RC, RD Output High Voltage	V_{CDH}	$I_{OH} = -2.0\text{ mA}$	2.4	-	-	V



6.2 DC Characteristics, continued

PARAMETER	SYM.	CONDITIONS	MIN.	TYP.	MAX.	UNIT
Port RE Sink Current	I_{EL}	$V_{OL} = 0.9V$	7.5	-	-	mA
Port RE Source Current	I_{EH}	$V_{OH} = 2.4V$	0.4	1.2	-	mA
\overline{INT} Pull-up Resistor	R_{INT}	-	50	250	1000	$K\Omega$
DIN Pin Pull-up Resistor	R_{DIN}	RE.2 used as serial input pin	50	250	1000	$K\Omega$
\overline{RES} Pull-up Resistor	R_{RES}	-	20	100	500	$K\Omega$

6.3 AC Characteristics

($V_{DD}-V_{SS} = 3.0 V$, $T_a = 25^\circ C$; unless otherwise specified)

PARAMETER	SYM.	CONDITIONS	MIN.	TYP.	MAX.	UNIT
Op. Frequency	FOSC	RC type	-	-	4000	KHz
		Crystal type 1 (Option low speed type)	-	32.768	-	
		Crystal type 2 (Option high speed type)	400	-	3580	
Frequency Deviation by Voltage drop for RC Oscillator	$\frac{\Delta f}{f}$	$\frac{f(3V) - f(2.4V)}{f(3V)}$	-	-	10	%
Instruction Cycle Time	T_I	One machine cycle	-	4/FOSC	-	mS
Serial Port Data Ready Time	T_{DR}	-	200	-	-	nS
Serial Port Data Hold Time	T_{DH}	-	200	-	-	nS
Reset Active Width	T_{RAW}	FOSC = 32.768 KHz	1	-	-	μS
Interrupt Active Width	T_{IAW}	FOSC = 32.768 KHz	1	-	-	μS

7. APPLICATION CIRCUIT

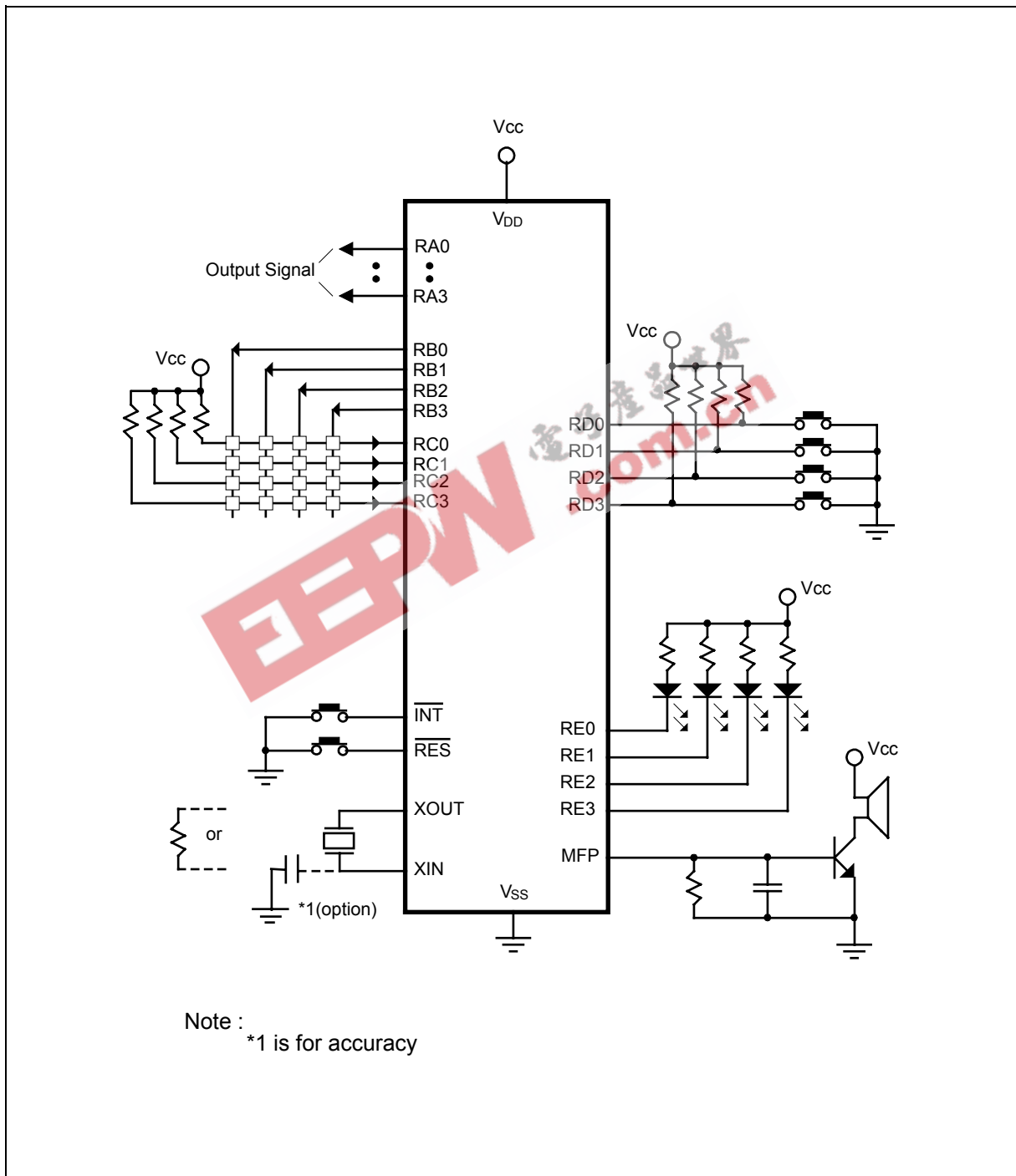

8. PACKAGE DIMENSIONS

8.1 18-Lead PDIP-300mil

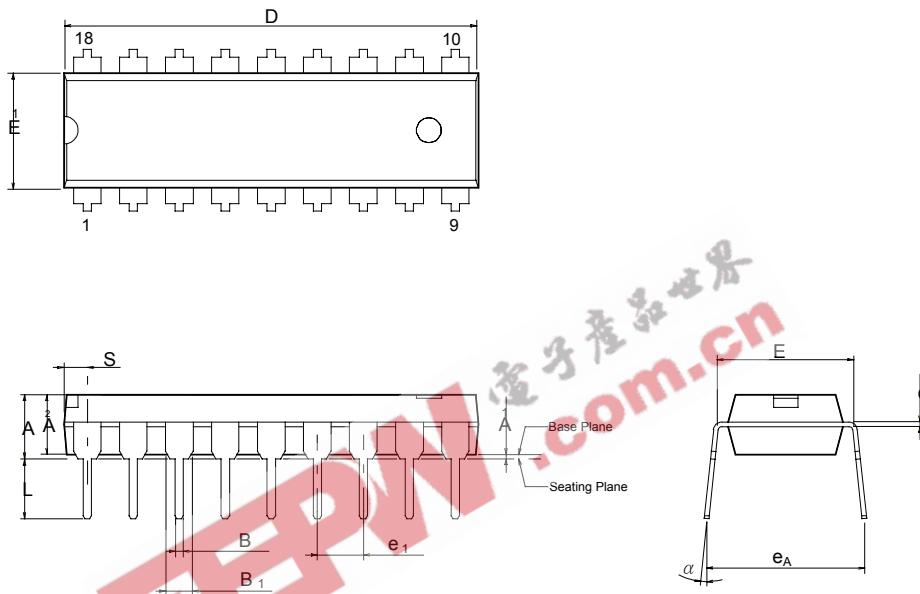

Symbol	Dimension in inches			Dimension in mm		
	Min.	Nom	Max.	Min.	Nom	Max.
A	—	—	0.175	—	—	4.45
A ₁	0.010	—	—	0.25	—	—
A ₂	0.125	0.130	0.135	3.18	3.30	3.43
B	0.016	0.018	0.022	0.41	0.46	0.56
B ₁	0.058	0.060	0.064	1.47	1.52	1.63
C	0.008	0.010	0.014	0.20	0.25	0.36
D	—	0.900	0.910	—	22.86	23.11
E	0.290	0.300	0.310	7.37	7.62	7.87
E ₁	0.245	0.250	0.255	6.22	6.35	6.48
e ₁	0.090	0.100	0.110	2.29	2.54	2.79
L	0.120	0.130	0.140	3.05	3.30	3.56
α	0	—	15	0	—	15
e _A	0.335	0.355	0.375	8.51	9.02	9.53
S	—	—	0.055	—	—	1.40

8.2 20-Lead PDIP

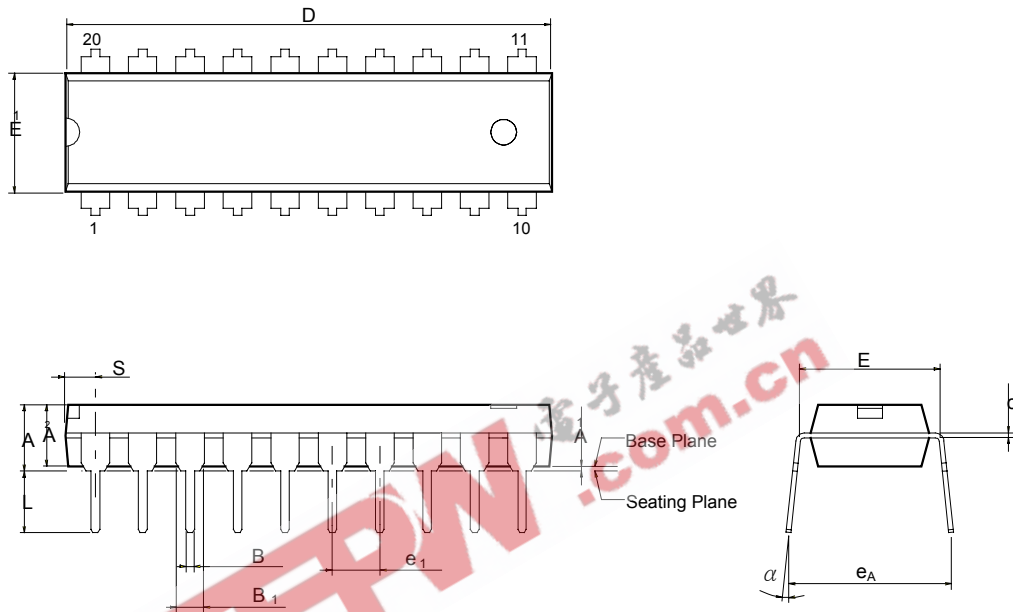

Symbol	Dimension in inches			Dimension in mm		
	Min.	Nom	Max.	Min.	Nom	Max.
A	—	—	0.175	—	—	4.45
A ₁	0.010	—	—	0.25	—	—
A ₂	0.125	0.130	0.135	3.18	3.30	3.43
B	0.016	0.018	0.022	0.41	0.46	0.56
B ₁	0.058	0.060	0.064	1.47	1.52	1.63
c	0.008	0.010	0.014	0.20	0.25	0.36
D	—	1.026	1.040	—	20.06	26.42
E	0.290	0.300	0.310	7.37	7.62	7.87
E ₁	0.245	0.250	0.255	6.22	6.35	6.48
e ₁	0.090	0.100	0.110	2.29	2.54	2.79
L	0.120	0.130	0.140	3.05	3.30	3.56
α	0	—	15	0	—	15
e _A	0.335	0.355	0.375	8.51	9.02	9.53
S	—	—	0.075	—	—	1.91



8.3 28-Lead P-DIP Skinny

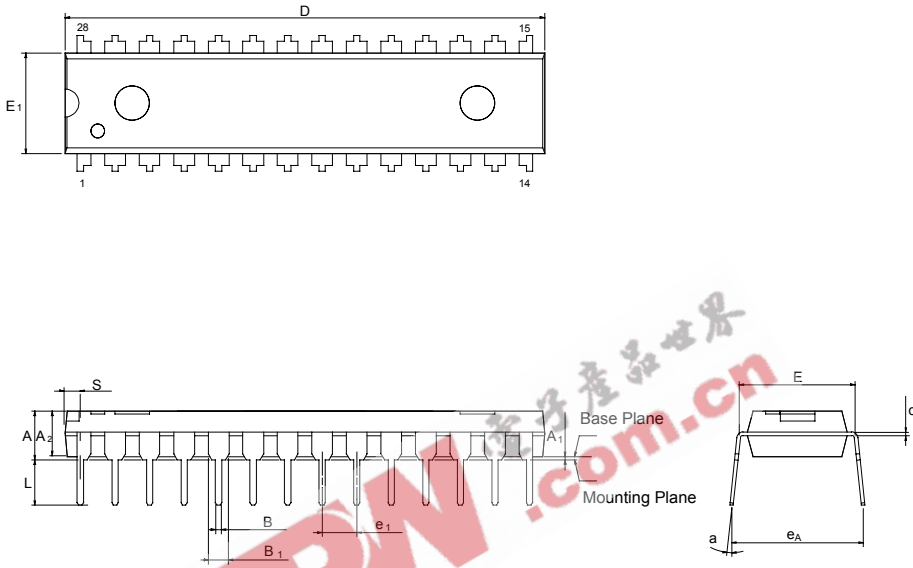

Symbol	Dimension in Inches			Dimension in mm		
	Min.	Nom	Max.	Min.	Nom	Max.
A	—	—	0.175	—	—	4.45
A ₁	0.010	—	—	0.25	—	—
A ₂	0.125	0.130	0.135	3.18	3.30	3.43
B	0.016	0.018	0.022	0.41	0.46	0.56
B ₁	0.058	0.060	0.064	1.47	1.52	1.63
c	0.008	0.010	0.014	0.20	0.25	0.36
D	—	1.388	1.400	—	35.26	35.56
E	0.300	0.310	0.320	7.62	7.87	8.13
E ₁	0.283	0.288	0.293	7.19	7.32	7.44
e ₁	0.090	0.100	0.110	2.29	2.54	2.79
L	0.120	0.130	0.140	3.05	3.30	3.56
a	0□	—	15□	0□	—	15□
e _A	0.330	0.350	0.370	8.38	8.89	9.40
S	—	—	0.055	—	—	1.40



8.4 20-Lead SOP-300mil

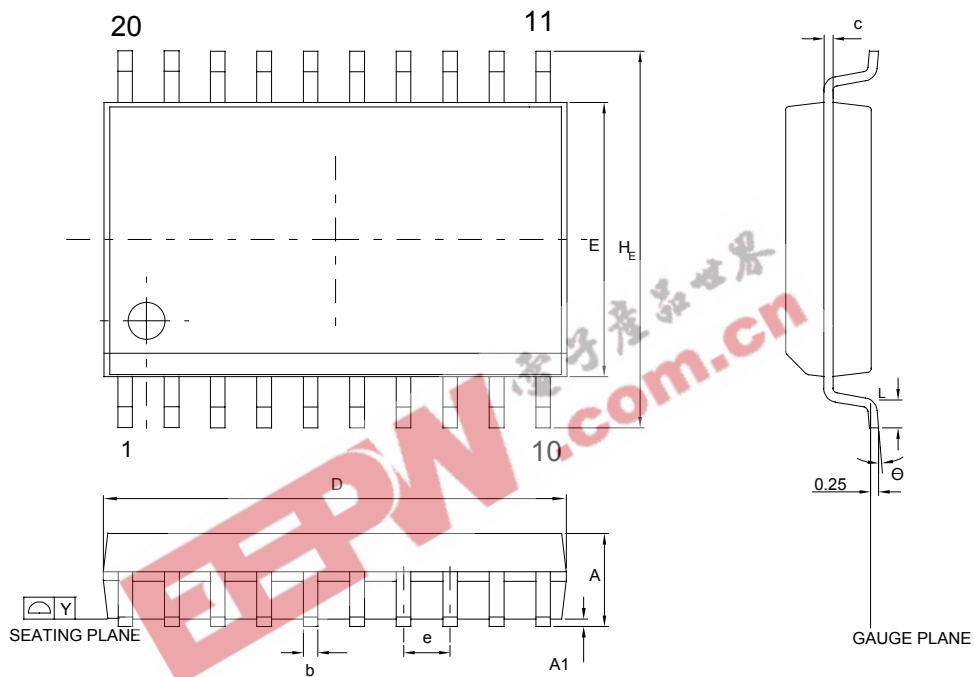

Control demensions are in milmeters .

Symbol	Dimension in mm		Dimension in inches	
	Min.	Max.	Min.	Max.
A	2.35	2.65	0.093	0.104
A1	0.10	0.30	0.004	0.012
b	0.33	0.51	0.013	0.020
c	0.23	0.32	0.009	0.013
E	7.40	7.60	0.291	0.299
D	12.60	13.00	0.496	0.512
e	1.27 BSC		0.050 BSC	
H _E	10.00	10.65	0.394	0.419
Y	0.10		0.004	
L	0.40	1.27	0.016	0.050
q	0	8	0	8



8.5 28-Lead SOP-300mil

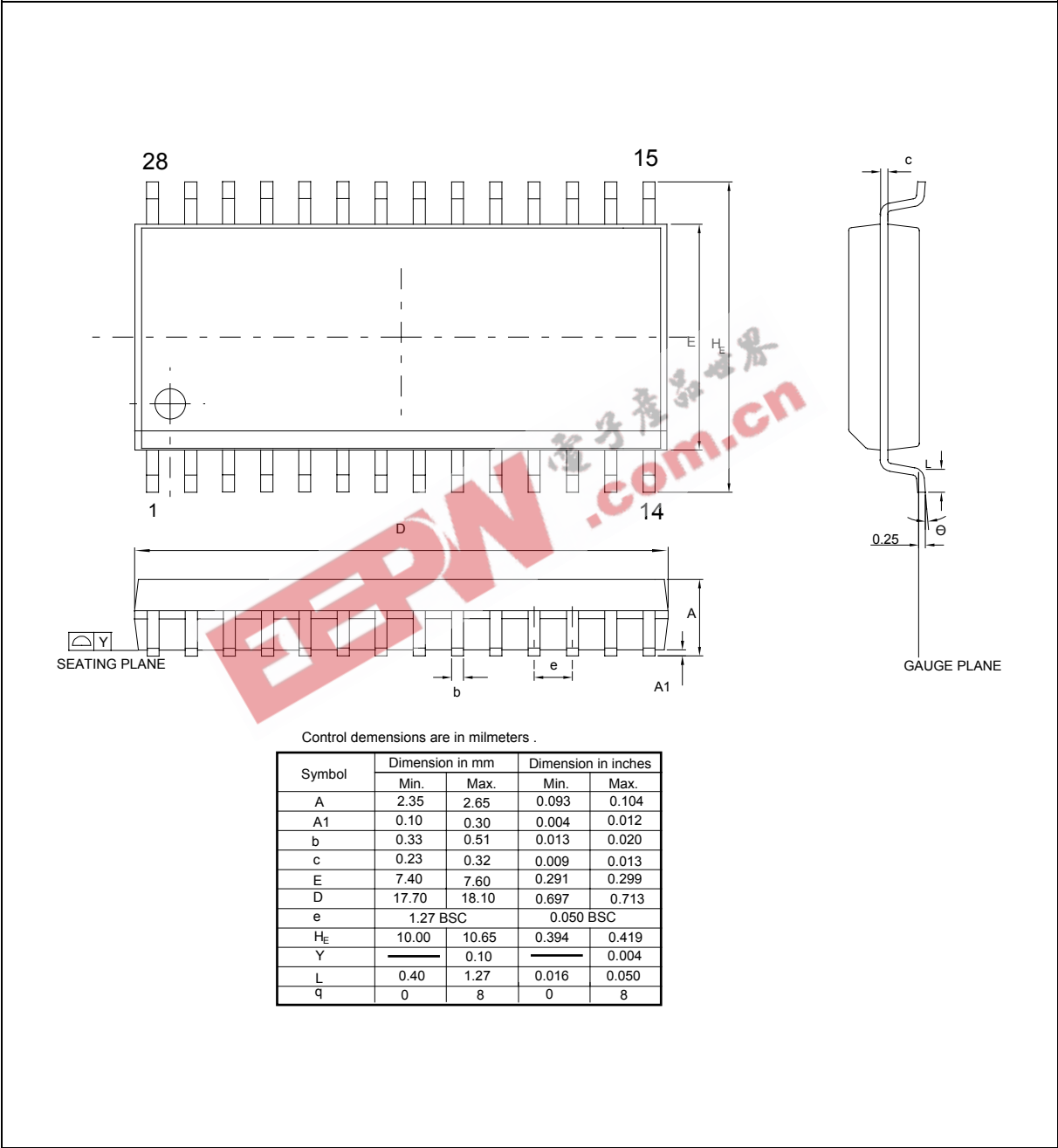



9. REVISION HISTORY

VERSION	DATE	DESCRIPTION
A2	-	Note: Update Hi freq range from 4.19 3.58MHz (C200)
A3	-	Note: RC is built-in schmitt trigger
A4	May 29, 2003	Note: Do not be floating when it is as input or output open-drain (NMOS type)

EEPW.com.cn 電子產品世界



Headquarters
No. 4, Creation Rd. III,
Science-Based Industrial Park,
Hsinchu, Taiwan
TEL: 886-3-5770066
FAX: 886-3-5665577
<http://www.winbond.com.tw/>

Taipei Office
9F, No.480, Rueiguang Rd.,
Neihu District, Taipei, 114,
Taiwan, R.O.C.
TEL: 886-2-8177-7168
FAX: 886-2-8751-3579

Winbond Electronics Corporation America
2727 North First Street, San Jose,
CA 95134, U.S.A.
TEL: 1-408-9436666
FAX: 1-408-5441798

Winbond Electronics Corporation Japan
7F Daini-ueno BLDG, 3-7-18
Shinyokohama Kohoku-ku,
Yokohama, 222-0033
TEL: 81-45-4781881
FAX: 81-45-4781800

Winbond Electronics (Shanghai) Ltd.
27F, 2299 Yan An W. Rd. Shanghai,
200336 China
TEL: 86-21-62365999
FAX: 86-21-62365998

Winbond Electronics (H.K.) Ltd.
Unit 9-15, 22F, Millennium City,
No. 378 Kwun Tong Rd.,
Kowloon, Hong Kong
TEL: 852-27513100
FAX: 852-27552064

*Please note that all data and specifications are subject to change without notice.
All the trade marks of products and companies mentioned in this data sheet belong to their respective owners.*