



# 1Mx32 5V Flash Module

## FEATURES

- Access Times of 70, 90, 120ns
- Packaging:
  - 66 pin, PGA Type, 1.185" square, Hermetic Ceramic HIP (Package 401)
  - 68 lead, 22mm Low Profile CQFP, 4.6mm (0.180"), (Package 509)
- Sector Architecture
  - One 16KByte Sectors
  - Two 8KByte Sectors
  - One 32KByte Sectors
  - Fifteen 64KByte Sectors
- 1,000,000 Erase/Program Cycles
- Organized as 1Mx32, user configurable as 2Mx16 or 4Mx8.
- Commercial, Industrial and Military Temperature Ranges
- 5V ± 10% for Read and Write Operations.
- Low Power CMOS
- Embedded Erase and Program Algorithm
- Built-in Decoupling Caps and Multiple Ground Pins for Low Noise Operation
- Weight
  - WEDF1M32B-XG2TX5 - 8 grams typical
  - WEDF1M32B-XHX5 - 13 grams typical

\* This product is under development, is not qualified or characterized and is subject to change or cancellation without notice.

### PIN CONFIGURATION FOR WF1M32B-XHX5

#### Top View

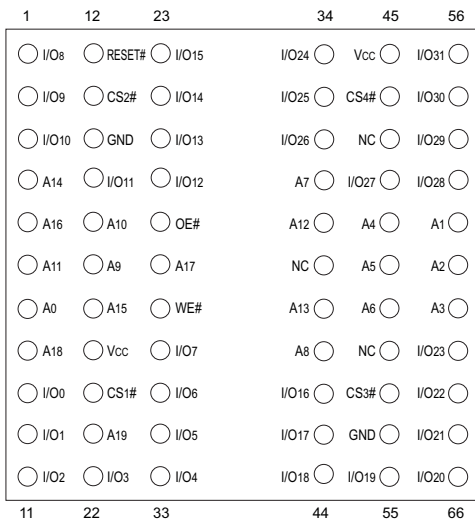

### PIN DESCRIPTION

I/O0-31	Data Inputs/Outputs
A0-19	Address Inputs
WE#	Write Enable
CS1-4#	Chip Selects
OE#	Output Enable
RESET#	Reset
Vcc	Power Supply
GND	Ground
NC	Not Connected

### Block Diagram

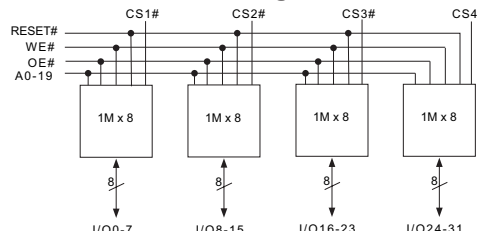

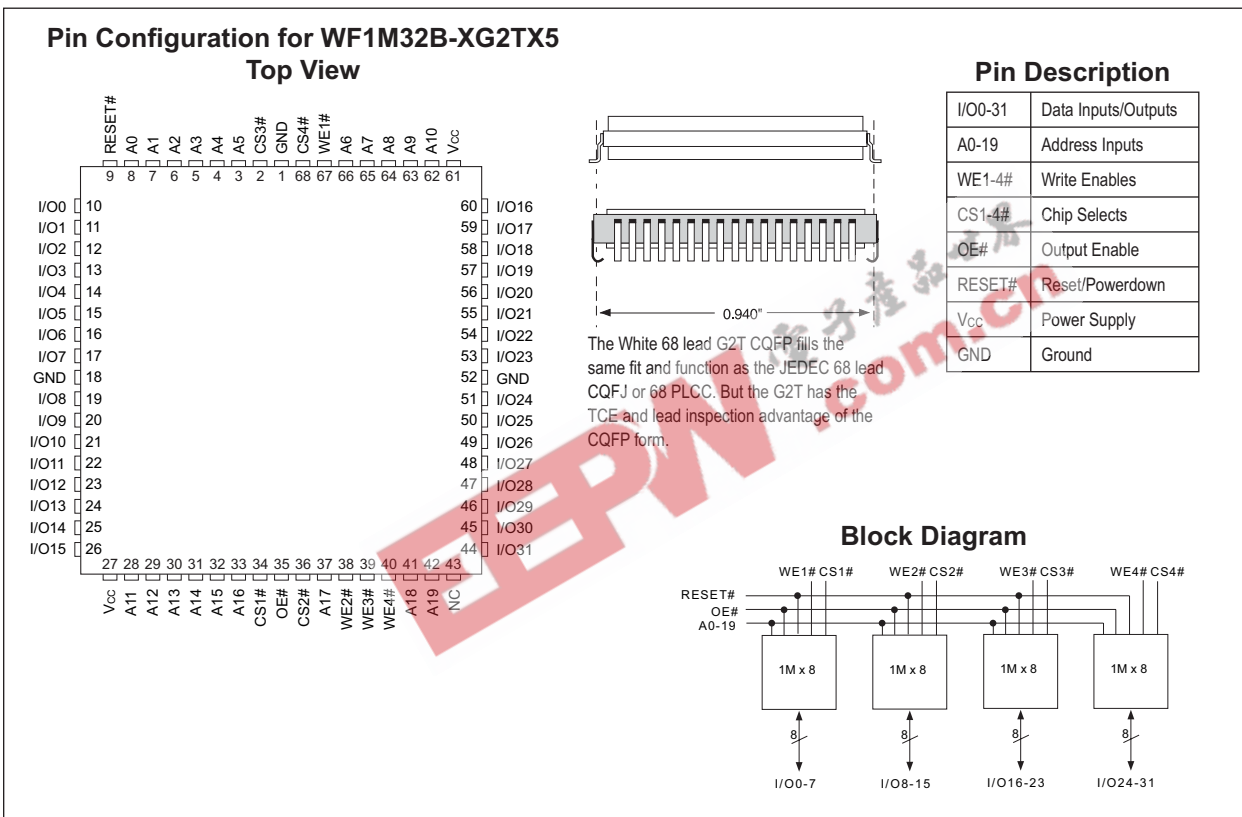



**ABSOLUTE MAXIMUM RATINGS**

Parameter		Unit
Voltage on Any Pin with Respect to GND – $V_{CC}$ and $V_{PP}$	-0.5 to +7.0	V
Voltage with Respect to GND – A9, OE#, and RESET (2)	-2.0 to +12.5 V	V
Voltage with Respect to GND – All other pins (1)	-2.0 to +7.0 V	V
Output Short Circuit Current	200	mA

NOTES:

1. Minimum DC voltage is -0.5V on input/output pins. During transitions, this level may undershoot to -2.0V for periods <20ns. Maximum DC voltage on input/output pins is  $V_{CC} + 0.5V$  which, during transitions, may overshoot to  $V_{CC} + 2.0V$  for periods <20ns.
2. Minimum DC input voltage on pins A9, OE#, and RESET is -0.5V. During voltage transitions, A9, OE#, and RESET may undershoot  $V_{SS}$  to -2.0V for periods of up to 20ns. See Figure 6. Maximum DC input voltage on pin A9 is +12.5V which may overshoot to +13.5V for periods up to 20ns.
3. Output shorted for no more than one second. No more than one output shorted at a time.

Stresses above those listed under "Absolute Maximum Ratings" may cause permanent damage to the device. This is a Stress rating only and functional operation of the device at these or any other conditions above those indicated in the operational sections of this specification is not implied. Exposure to absolute maximum rating conditions for extended periods may affect device reliability.

**RECOMMENDED OPERATING CONDITIONS**

Parameter	Symbol	Min	Max	Unit
Supply Voltage	$V_{CC}$	4.5	5.5	V
Input High Voltage	$V_{IH}$	2.0	$V_{CC} + 0.5$	V
Input Low Voltage	$V_{IL}$	-0.5	+0.8	V
Operating Temp. (Mil.)	$T_A$	-55	+125	°C

**CAPACITANCE**

$T_A = +25^\circ C$

Parameter	Symbol	Conditions	Max	Unit
OE# capacitance	$C_{OE}$	$V_{IN} = 0 V, f = 1.0 MHz$	50	pF
WE#1-4 capacitance	$C_{WE}$	$V_{IN} = 0 V, f = 1.0 MHz$	20	pF
CS1-4 capacitance	$C_{CS}$	$V_{IN} = 0 V, f = 1.0 MHz$	20	pF
Data I/O capacitance	$C_{I/O}$	$V_{I/O} = 0 V, f = 1.0 MHz$	20	pF
Address input capacitance	$C_{AD}$	$V_{IN} = 0 V, f = 1.0 MHz$	50	pF

This parameter is guaranteed by design but not tested.

**DATA RETENTION**

Parameter	Test Conditions	Min	Unit
Minimum Pattern Data	150°C	10	Years
Retention Time	125°C	20	Years

**AC TEST CIRCUIT**

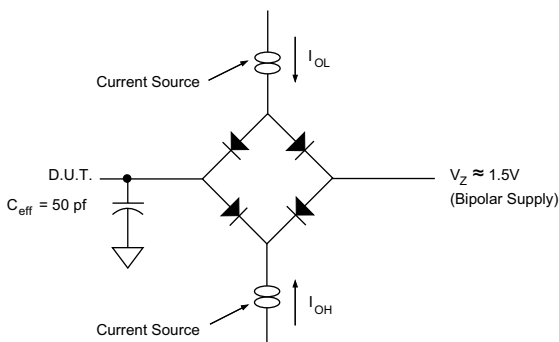

**AC TEST CONDITIONS**

Parameter	Typ	Unit
Input Pulse Levels	$V_{IL} = 0, V_{IH} = 2.5$	V
Input Rise and Fall	5	ns
Input and Output Reference Level	1.5	V
Output Timing Reference Level	1.5	V

NOTES:

- $V_Z$  is programmable from -2V to +7V.
- $I_{OL}$  &  $I_{OH}$  programmable from 0 to 16mA.
- Tester Impedance  $Z_0 = 75 \Omega$ .
- $V_Z$  is typically the midpoint of  $V_{OH}$  and  $V_{OL}$ .
- $I_{OL}$  &  $I_{OH}$  are adjusted to simulate a typical resistive load circuit.
- ATE tester includes jig capacitance.



**DC CHARACTERISTICS – CMOS COMPATIBLE**

V<sub>CC</sub> = 5.0V, GND = 0V, -55°C ≤ T<sub>A</sub> ≤ +125°C

Parameter	Symbol	Conditions	Min	Max	Unit
Input Leakage Current	I <sub>LI</sub>	V <sub>IN</sub> = V <sub>CC</sub> to GND		10	μA
Output Leakage Current	I <sub>LO</sub>	V <sub>OUT</sub> = V <sub>CC</sub> to GND		10	μA
V <sub>CC</sub> Read Current (1, 2)	I <sub>CC1</sub>	CS# = V <sub>IL</sub> , OE# = V <sub>IH</sub> , f = 5MHz, I <sub>OUT</sub> = 0mA		160	mA
V <sub>CC</sub> Write Current (2, 3, 4)	I <sub>CC2</sub>	CS# = V <sub>IL</sub> , OE# = V <sub>IH</sub>		200	mA
V <sub>CC</sub> Standby Current (2, 5)	I <sub>CC3</sub>	CS# = RESET# = OE# = CS = V <sub>IH</sub> , f = 5MHz		20.0	μA
Output Low Voltage	V <sub>OL</sub>	V <sub>CC</sub> = 4.5, I <sub>OL</sub> = 5.8 mA		0.45	V
Output High Voltage	V <sub>OH</sub>	V <sub>CC</sub> = 4.5, I <sub>OH</sub> = -2.5 mA	2.4		V
Low V <sub>CC</sub> Lock-Out Voltage (4)	V <sub>LKO</sub>		3.2	4.2	V

NOTES:

1. The I<sub>CC</sub> current listed is typically less than 2mA/MHz, with OE# at V<sub>IH</sub>.
2. Maximum I<sub>CC</sub> specifications are tested with V<sub>CC</sub> = V<sub>CC</sub> max
3. I<sub>CC</sub> active while Embedded Erase or Embedded Program is in progress.
4. Not 100% tested.
5. I<sub>CC3</sub> = 20μA max at extended temperature (> +85°C).

**AC CHARACTERISTICS – WRITE/ERASE/PROGRAM OPERATIONS – CS# CONTROLLED**

V<sub>CC</sub> = 5.0V, GND = 0V, -55°C ≤ T<sub>A</sub> ≤ +125°C

Parameter	Symbol		-70		-90		-120		Unit
			Min	Max	Min	Max	Min	Max	
Write Cycle Time	t <sub>AVAV</sub>	t <sub>WC</sub>	70		90		120		ns
Chip Select Setup Time	t <sub>ELWL</sub>	t <sub>CS</sub>	0		0		0		ns
Write Enable Pulse Width	t <sub>WLWH</sub>	t <sub>WP</sub>	345		45		50		ns
Address Setup Time	t <sub>AWWH</sub>	t <sub>AS</sub>	0		0		0		ns
Data Setup Time	t <sub>DVWH</sub>	t <sub>DS</sub>	35		45		50		ns
Data Hold Time	t <sub>WHDX</sub>	t <sub>DH</sub>	0		0		0		ns
Address Hold Time	t <sub>WLAX</sub>	t <sub>AH</sub>	45		45		50		ns
Chip Select Hold Time	t <sub>WHEH</sub>	t <sub>CH</sub>	0		0		0		ns
Write Enable Pulse Width High	t <sub>WHWL</sub>	t <sub>WPH</sub>	20		20		20		NS
Programming Operation (2)	t <sub>WHWH1</sub>			300		300		300	μs
Sector Erase Operation (3)	t <sub>WHWH2</sub>			8		8		8	sec
Write Recovery before Read	t <sub>WHECL</sub>		0		0		0		μs
Chip Programming Time				50		50		50	sec

NOTES:

1. Guaranteed by design, not tested.
2. Typical value for t<sub>WHWH1</sub> is 7μs.
3. Typical value for t<sub>WHWH2</sub> is 1sec.



**AC CHARACTERISTICS – WRITE OPERATIONS – CS# CONTROLLED<sup>(1)</sup>**

V<sub>CC</sub> = 5.0V, GND = 0V, -55°C ≤ T<sub>A</sub> ≤ +125°C

Parameter	Symbol		-70		-90		-120		Unit
			Min	Max	Min	Max	Min	Max	
Write Enable Cycle Time	t <sub>WAV</sub>	t <sub>WC</sub>	70		90		120		ns
Write Enable Setup Time	t <sub>WLEL</sub>	t <sub>WS</sub>	0		0		0		ns
Chip Select Pulse Width	t <sub>LEH</sub>	t <sub>CP</sub>	35		45		50		ns
Address Setup Time	t <sub>AVEH</sub>	t <sub>AS</sub>	0		0		0		ns
Data Setup Time	t <sub>DVEH</sub>	t <sub>DS</sub>	30		45		50		ns
Data Hold Time	t <sub>EDX</sub>	t <sub>DH</sub>	0		0		0		ns
Address Hold Time	t <sub>EHAX</sub>	t <sub>AH</sub>	45		45		50		ns
Write Enable Hold Time	t <sub>EHWH</sub>	t <sub>WH</sub>	0		0		0		ns
Chip Select Pulse Width High	t <sub>EHEL</sub>	t <sub>EPH</sub>	20		20		20		μs
Programming Operation (1)	t <sub>WHWH1</sub>			300		300		300	sec
Sector Erase Operation (2)	t <sub>WHWH2</sub>			8		8		8	μs
Write Recovery before Read	t <sub>EHCL</sub>		0		0		0		μs

NOTES:

1. Typical value for t<sub>WHWH1</sub> is 7μs.
2. Typical value for t<sub>WHWH2</sub> is 1sec.

**AC CHARACTERISTICS – READ-ONLY OPERATIONS**

V<sub>CC</sub> = 5.0V, GND = 0V, -55°C ≤ T<sub>A</sub> ≤ +125°C

Parameter	Symbol		-70		-90		-120		Unit
			Min	Max	Min	Max	Min	Max	
Read Cycle Time	t <sub>WAV</sub>	t <sub>RC</sub>	70		90		120		ns
Address Access Time	t <sub>AVQV</sub>	t <sub>ACC</sub>		70		90		120	ns
Chip Select to Output Valid (1)	t <sub>ELQV</sub>	t <sub>CE</sub>		70		90		120	ns
Output Enable to Output Valid (1)	t <sub>GLQV</sub>	t <sub>OE</sub>		30		35		50	ns
Chip Select to Output Low Z (2)	t <sub>ELQX</sub>	t <sub>LZ</sub>	0		0		0		ns
Chip Select High to Output High Z (2)	t <sub>EHQZ</sub>	t <sub>HZ</sub>		20		20		50	ns
Output Enable to Output Low Z (2)	t <sub>GLQX</sub>	t <sub>OLZ</sub>	0		0		0		ns
Output Enable High to Output High Z (2)	t <sub>GHQZ</sub>	t <sub>DF</sub>		20		20		30	ns
Output Hold from Addresses, CS# or OE# Change, Whichever is First (2)		t <sub>OH</sub>	0		0		0		ns

NOTES:

1. OE# may be delayed up to t<sub>CE-tOE</sub> after the falling edge of CS# without impact on t<sub>CS</sub>.
2. Guaranteed by design, not tested.



**PACKAGE 509: 68 LEAD, CERAMIC QUAD FLAT PACK, CQFP (G2T)**

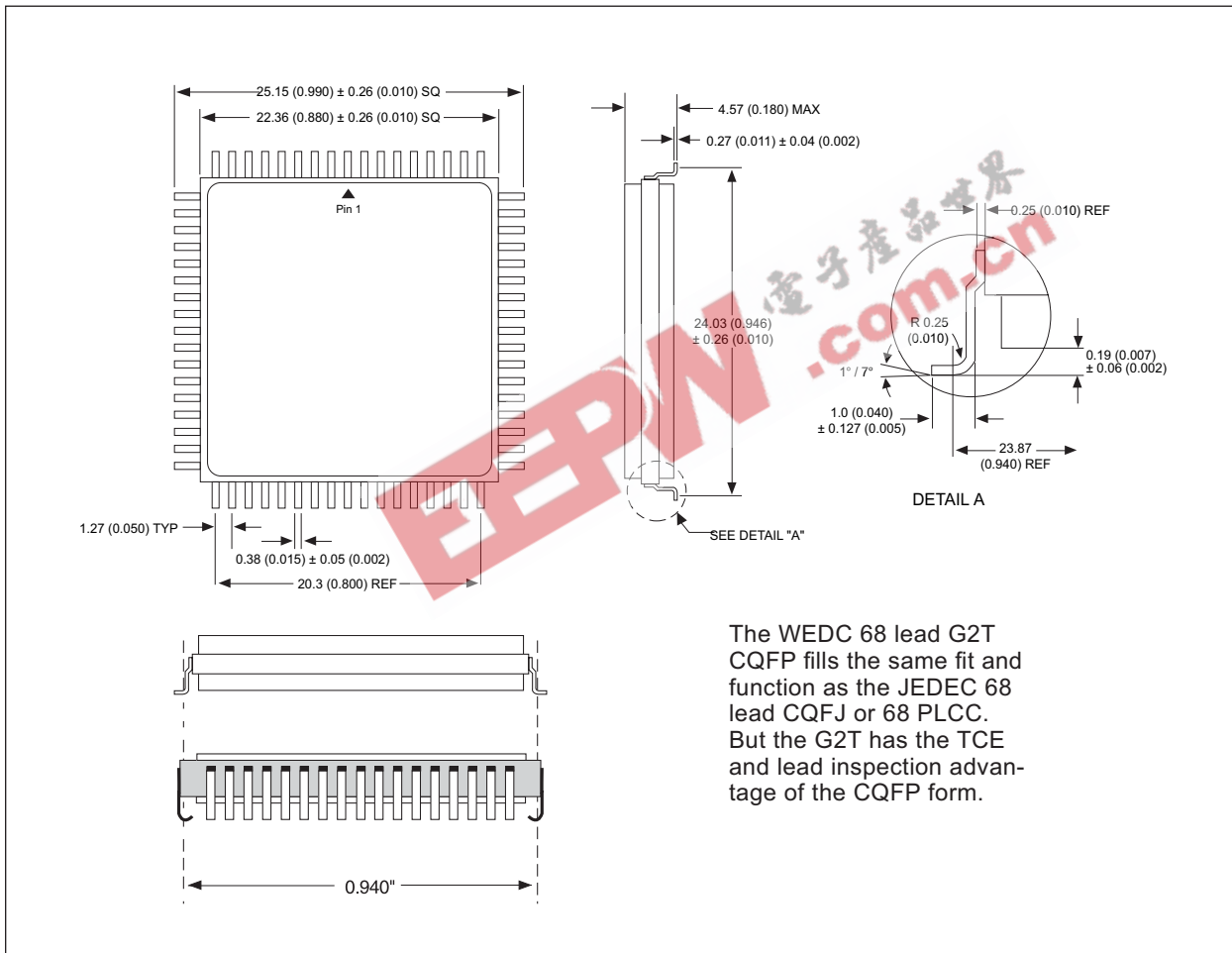

The WEDC 68 lead G2T CQFP fills the same fit and function as the JEDEC 68 lead CQFJ or 68 PLCC. But the G2T has the TCE and lead inspection advantage of the CQFP form.

ALL LINEAR DIMENSIONS ARE MILLIMETERS AND PARENTHETICALLY IN INCHES



**PACKAGE 401: 66 PIN, PGA TYPE, CERAMIC HEX-IN-LINE PACKAGE, HIP (H)**

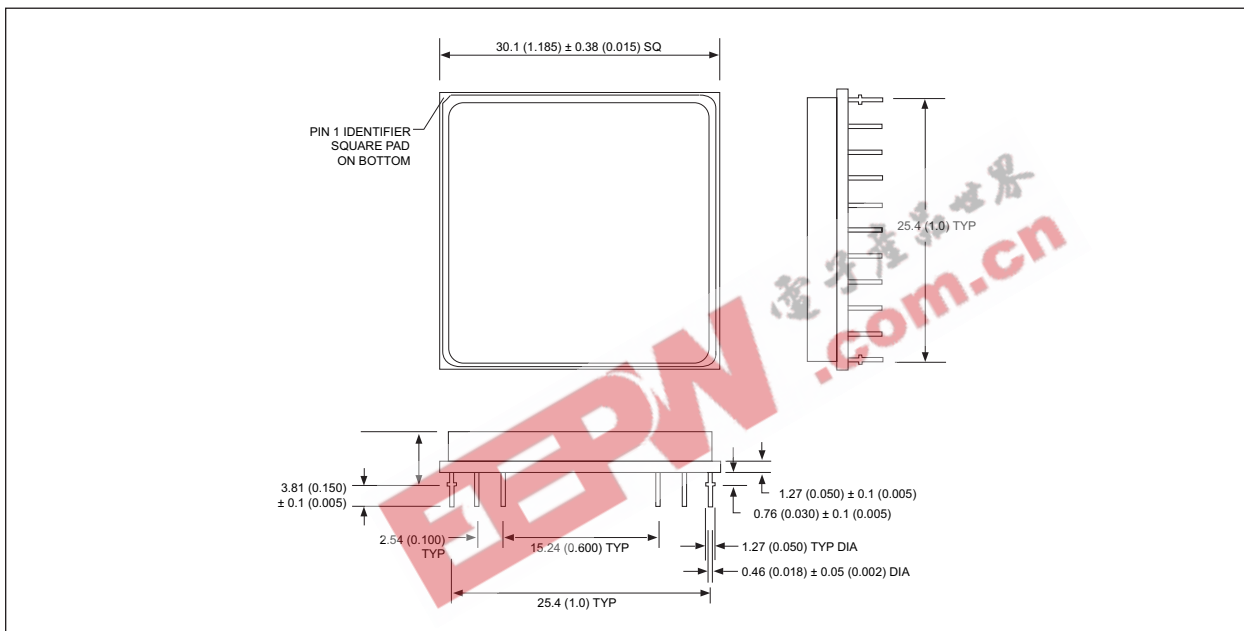

ALL LINEAR DIMENSIONS ARE MILLIMETERS AND PARENTHETICALLY IN INCHES



**ORDERING INFORMATION**

