

W91473 SERIES



14-MEMORY TONE/PULSE SWITCHABLE DIALER WITH HANDFREE AND LOCK FUNCTIONS

GENERAL DESCRIPTION

The W91473 series are Si-gate CMOS IC tone/pulse switchable dialers containing a 14-channel automatic dialing memory, including a 16-digit \times 3 emergency dialing memory and a 16-digit \times 10 channel repertory memory that provides a 32-digit mercury memory. These dialers also provide flash, clear, hold, lock, and one-key redial functions.

FEATURES

- DTMF/Pulse switchable dialer
- 32-digit LNB (last number buffer) memory
- 32-digit mercury memory
- 16-digit \times 3 one-touch direct repertory memory
- 16-digit \times 10 direct repertory memory
- Uses 7 \times 5 keyboard
- Flash time: 98 mS, 305 mS, or 600 mS (selectable by keypad option)
- Minimum tone output duration: 93 mS
- Minimum intertone pause: 93 mS
- On-chip power-on reset
- Uses 3.579545 MHz crystal or ceramic resonator
- Packaged in 22, 24, or 28-pin plastic DIP
- The different dialers in the W91473 series are shown in the following table:

TYPE NO.	PULSE (ppS)	MEMORY	MERCURY MEMORY	HOLD	HANDFREE	LOCK	PACKAGE
W91473	10	14	Yes	Yes	-	-	22
W91473L	10	14	-	-	-	Yes	22
W91473A	10	14	Yes	Yes	Yes	-	24
W91473AL	10	14	-	-	Yes	Yes	24
W91473B	10/20	14	Yes	Yes	Yes	-	28
W91473BL	10/20	14	Yes	Yes	Yes	Yes	28
W91473C	10/20	14	Save Memory	Yes	Yes	-	28
W91473CL	10/20	14	Save Memory	Yes	Yes	Yes	28
W91473D	10	14	Save Memory	-	-	-	22
W91473DL	10	14	Save Memory	-	-	Yes	22

W91473 SERIES



PIN CONFIGURATIONS

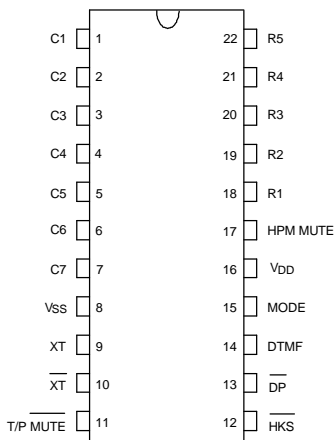

W91473/D

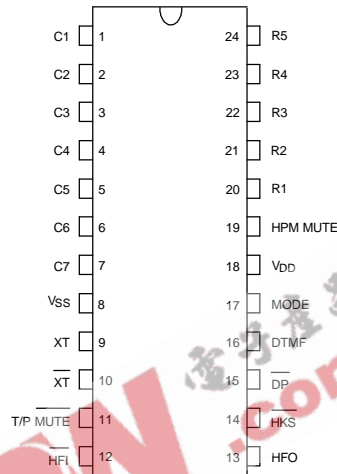

W91473A

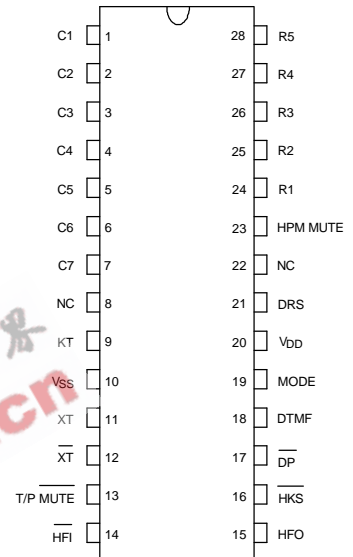

W91473B/C

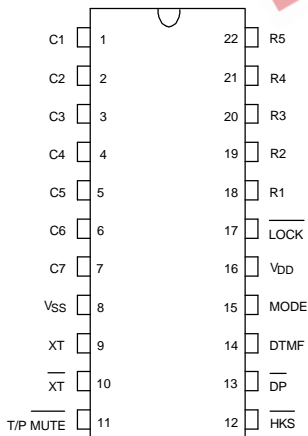

W91473L/DL

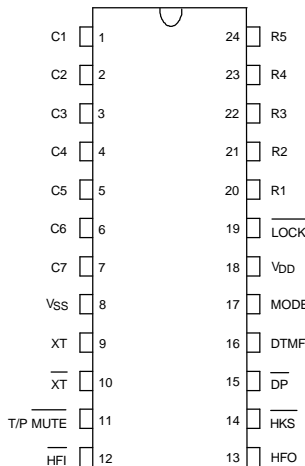

W91473AL

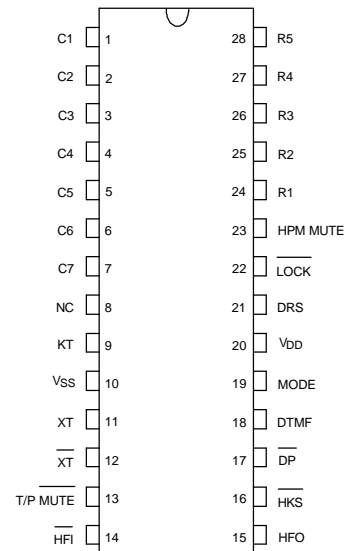

W91473BL/CL

W91473 SERIES



PIN DESCRIPTION

SYMBOL	22-PIN	24-PIN	28-PIN	I/O	FUNCTION
Column-Row Inputs	1-7 & 18-22	1-7 & 20-24	1-8 & 24-28	I	The keyboard input may be used with either the standard 7 × 5 keyboard or an inexpensive single contact (form A) keyboard. Electronic input with μ C can also be used. A valid key entry is defined by a single row being connected to a single column.
XT, $\overline{\text{XT}}$	9, 10	9, 10	11, 12	I, O	A built-in inverter provides oscillation with an inexpensive 3.579545 MHz crystal or ceramic resonator.
T/P MUTE	11	11	13	O	The T/P MUTE is a conventional CMOS N-channel open drain output. The output transistor is switched on during pulse and tone mode dialing sequence and flash break. Otherwise, it is switched off.
$\overline{\text{DP}}$	13	15	17	O	N-channel open drain dialing pulse output (Figure 1). Flash key causes $\overline{\text{DP}}$ to go active when in pulse mode and tone mode.
MODE	15	17	19	I	Pulling mode pin to Vss places the dialer in tone mode. Pulling mode pin to VDD places the dialer in pulse mode (10 ppS, M/B = 2:3). Leaving mode pin floating places the dialer in pulse mode (10 ppS, M/B = 1:2).
$\overline{\text{HKS}}$	12	14	16	I	Hook switch input. $\overline{\text{HKS}} = 1$: On-hook state. Chip in sleep mode, no operation. $\overline{\text{HKS}} = 0$: Off-hook state. Chip enabled for normal operation. $\overline{\text{HKS}}$ pin is pulled to VDD by internal resistor.

W91473 SERIES



Pin Description, continued

SYMBOL	22-PIN	24-PIN	28-PIN	I/O	FUNCTION																																				
HPM MUTE	17 (only for W91473/D)	19 (only for W91473A)	23	O	The HPM MUTE is a conventional inverter output. During pulse dialing, flash, hold, and mercury mute functions, this pin will output an active high. It remains in a low state at all other times.																																				
NC	-	-	8, 22 (W91473 B/C)	-	No connection.																																				
$\overline{\text{LOCK}}$	17 (W91473L /DL)	19 (W91473 AL)	22 (W91473 BL/CL)	I	The function of the $\overline{\text{LOCK}}$ pin is shown below: <table border="1" style="margin-left: 20px;"> <thead> <tr> <th>LOCK PIN</th> <th>FUNCTION</th> </tr> </thead> <tbody> <tr> <td>VDD</td> <td>"0," "9" dialing inhibited</td> </tr> <tr> <td>Floating</td> <td>Normal dialing</td> </tr> <tr> <td>Vss</td> <td>"0" dialing inhibited</td> </tr> </tbody> </table>	LOCK PIN	FUNCTION	VDD	"0," "9" dialing inhibited	Floating	Normal dialing	Vss	"0" dialing inhibited																												
LOCK PIN	FUNCTION																																								
VDD	"0," "9" dialing inhibited																																								
Floating	Normal dialing																																								
Vss	"0" dialing inhibited																																								
DTMF	14	16	18	O	In pulse mode, remains in low state at all times. In tone mode, outputs a dual or single tone. Detailed timing diagram for tone mode is shown in Figure 2. <table border="1" style="margin-left: 20px;"> <thead> <tr> <th colspan="4">OUTPUT FREQUENCY</th> </tr> <tr> <th></th> <th>Specified</th> <th>Actual</th> <th>Error %</th> </tr> </thead> <tbody> <tr> <td>R1</td> <td>697</td> <td>699</td> <td>+0.28</td> </tr> <tr> <td>R2</td> <td>770</td> <td>766</td> <td>-0.52</td> </tr> <tr> <td>R3</td> <td>852</td> <td>848</td> <td>-0.47</td> </tr> <tr> <td>R4</td> <td>941</td> <td>948</td> <td>+0.74</td> </tr> <tr> <td>C1</td> <td>1209</td> <td>1216</td> <td>+0.57</td> </tr> <tr> <td>C2</td> <td>1336</td> <td>1332</td> <td>-0.30</td> </tr> <tr> <td>C3</td> <td>1477</td> <td>1472</td> <td>-0.34</td> </tr> </tbody> </table>	OUTPUT FREQUENCY					Specified	Actual	Error %	R1	697	699	+0.28	R2	770	766	-0.52	R3	852	848	-0.47	R4	941	948	+0.74	C1	1209	1216	+0.57	C2	1336	1332	-0.30	C3	1477	1472	-0.34
OUTPUT FREQUENCY																																									
	Specified	Actual	Error %																																						
R1	697	699	+0.28																																						
R2	770	766	-0.52																																						
R3	852	848	-0.47																																						
R4	941	948	+0.74																																						
C1	1209	1216	+0.57																																						
C2	1336	1332	-0.30																																						
C3	1477	1472	-0.34																																						
VDD, Vss	16, 8	1, 8	20, 10	I	Power input pins.																																				

W91473 SERIES



Pin Description, continued

SYMBOL	22-PIN	24-PIN	28-PIN	I/O	FUNCTION																																								
$\overline{\text{HFI}}$, HFO	-	12, 13	14, 15	I, O	<p>Handfree control pins. A low pulse on the $\overline{\text{HFI}}$ input pin toggles the handfree control state. Status of the handfree control state is listed in the following table:</p> <table border="1"> <thead> <tr> <th colspan="2">CURRENT STATE</th> <th colspan="3">NEXT STATE</th> </tr> <tr> <th>Hook Sw.</th> <th>HFO</th> <th>Input</th> <th>HFO</th> <th>Dialing</th> </tr> </thead> <tbody> <tr> <td>-</td> <td>Low</td> <td>$\overline{\text{HFI}} \downarrow 0$</td> <td>High</td> <td>Yes</td> </tr> <tr> <td>On Hook</td> <td>High</td> <td>$\overline{\text{HFI}} \downarrow 0$</td> <td>Low</td> <td>No</td> </tr> <tr> <td>Off Hook</td> <td>High</td> <td>$\overline{\text{HFI}} \downarrow 0$</td> <td>Low</td> <td>Yes</td> </tr> <tr> <td>On Hook</td> <td>-</td> <td>Off Hook</td> <td>Low</td> <td>Yes</td> </tr> <tr> <td>Off Hook</td> <td>Low</td> <td>On Hook</td> <td>Low</td> <td>No</td> </tr> <tr> <td>Off Hook</td> <td>High</td> <td>On Hook</td> <td>High</td> <td>Yes</td> </tr> </tbody> </table> <p>The $\overline{\text{HFI}}$ pin is pulled to VDD by an internal resistor.</p>	CURRENT STATE		NEXT STATE			Hook Sw.	HFO	Input	HFO	Dialing	-	Low	$\overline{\text{HFI}} \downarrow 0$	High	Yes	On Hook	High	$\overline{\text{HFI}} \downarrow 0$	Low	No	Off Hook	High	$\overline{\text{HFI}} \downarrow 0$	Low	Yes	On Hook	-	Off Hook	Low	Yes	Off Hook	Low	On Hook	Low	No	Off Hook	High	On Hook	High	Yes
CURRENT STATE		NEXT STATE																																											
Hook Sw.	HFO	Input	HFO	Dialing																																									
-	Low	$\overline{\text{HFI}} \downarrow 0$	High	Yes																																									
On Hook	High	$\overline{\text{HFI}} \downarrow 0$	Low	No																																									
Off Hook	High	$\overline{\text{HFI}} \downarrow 0$	Low	Yes																																									
On Hook	-	Off Hook	Low	Yes																																									
Off Hook	Low	On Hook	Low	No																																									
Off Hook	High	On Hook	High	Yes																																									
KT	-	-	9	O	<p>Keytone signal output. The keytone will be generated in all valid keys are pressed in tone mode. Frequency is 600 Hz and duration is 35 mS.</p>																																								
DRS	-	-	21	I	<p>Dial rate selection. This pin is pulled to VDD by an internal resistor.</p> <table border="1"> <thead> <tr> <th>DRS</th> <th>MODE PIN</th> <th>TONE/PULSE</th> <th>DIAL RATE</th> <th>M/B</th> </tr> </thead> <tbody> <tr> <td rowspan="3">1</td> <td>VDD</td> <td>Pulse</td> <td>10 ppS</td> <td>2:3</td> </tr> <tr> <td>Floating</td> <td>Pulse</td> <td>10 ppS</td> <td>1:2</td> </tr> <tr> <td>Vss</td> <td>Tone</td> <td>-</td> <td>-</td> </tr> <tr> <td rowspan="3">0</td> <td>VDD</td> <td>Pulse</td> <td>10 ppS</td> <td>1:2</td> </tr> <tr> <td>Floating</td> <td>Pulse</td> <td>20 ppS</td> <td>1:2</td> </tr> <tr> <td>Vss</td> <td>Tone</td> <td>-</td> <td>-</td> </tr> </tbody> </table>	DRS	MODE PIN	TONE/PULSE	DIAL RATE	M/B	1	VDD	Pulse	10 ppS	2:3	Floating	Pulse	10 ppS	1:2	Vss	Tone	-	-	0	VDD	Pulse	10 ppS	1:2	Floating	Pulse	20 ppS	1:2	Vss	Tone	-	-									
DRS	MODE PIN	TONE/PULSE	DIAL RATE	M/B																																									
1	VDD	Pulse	10 ppS	2:3																																									
	Floating	Pulse	10 ppS	1:2																																									
	Vss	Tone	-	-																																									
0	VDD	Pulse	10 ppS	1:2																																									
	Floating	Pulse	20 ppS	1:2																																									
	Vss	Tone	-	-																																									

W91473 SERIES



BLOCK DIAGRAM

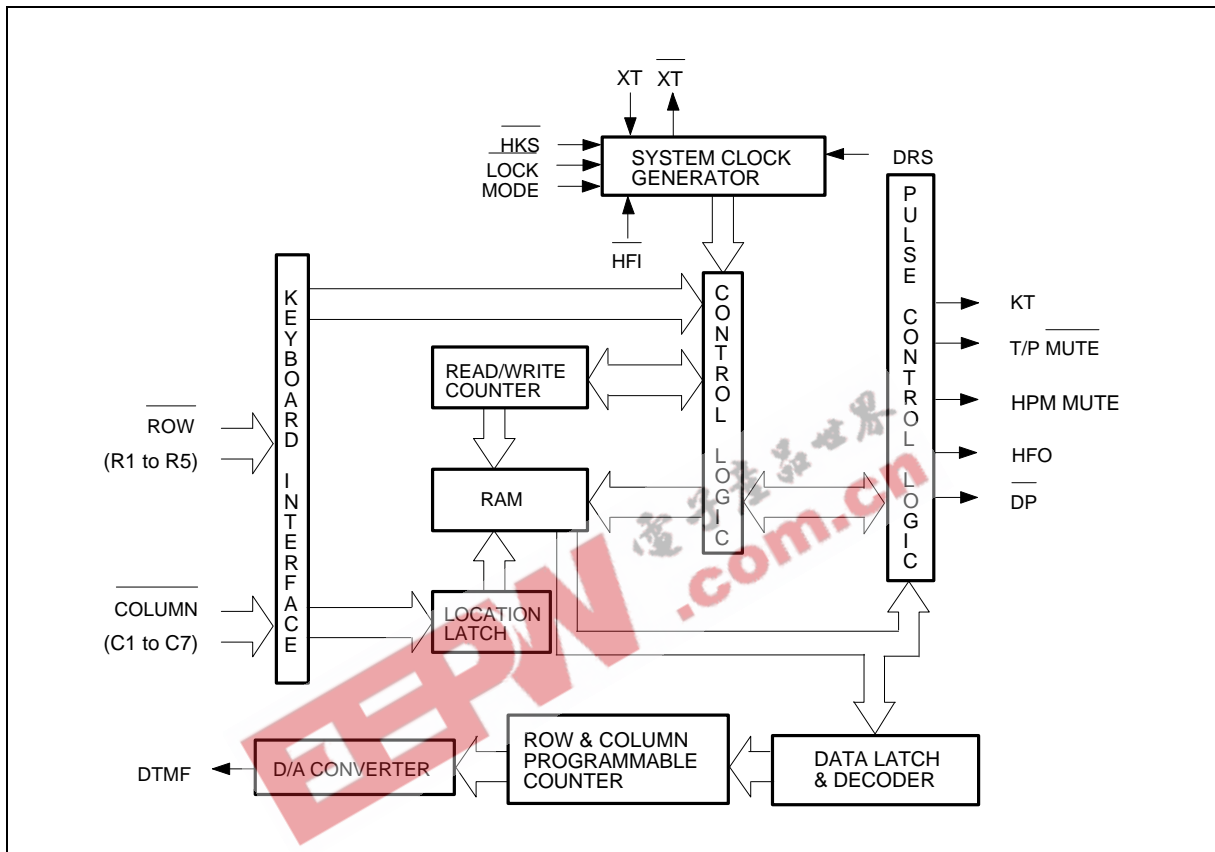

FUNCTIONAL DESCRIPTION

Keyboard Operation

C1	C2	C3	C4	C5	C6	C7	
1	2	3	S	M00	M05	EM1	R1
4	5	6		M01	M06	EM2	R2
7	8	9	CLR	M02	M07	EM3	R3
*T	0	#	R/P	M03	M08	H	R4
F1	F2	F3	R	M04	M09	*MER	R5

Note: *MER location in W91473C/CL or W91473D/DL is SAVE memory.

- S: Store function key

W91473 SERIES



- F1, F2, F3: Flash keys
- R: One-key redial
- H: Hold function key
- M0j: Direct repertory memory
- EMi: One-touch memory for emergency call
- */T: * & P→T
- CLR: Clear key
- R/P: Redial and pause function key
- MER: One-touch memory for mercury code dialing

Note: Dn = 0 to 9, *, #, M0j = M00 to M09 (j = 0 to 9).

Normal Dialing

(or &), , , ...,

1. D1, D2, ..., Dn will be dialed out.
2. Dialing length is unlimited, but redial is inhibited if length oversteps 32 digits.

Redialing

1. , , , ..., BUSY, Come ,

(or &) ,

or & , , , ..., BUSY, Come

,

The key can execute redial function only as first key-in after off-hook. Otherwise, it will execute pause function.

2. (or &) , , , ..., ,

a. The one-key redial function timing diagram is shown in Figure 4.

b. If dialing to is completed, pressing the key will cause the pulse output pin of

to go low for 2.2 seconds. Break time and a 600 mS pause will automatically be added.

c. If the key is pressed before the pulses for the number dialed out are completed, it will be ignored.



Number Store

1. OFF HOOK (or ON HOOK & $\overline{\text{HFI}} \overline{\text{i}} \underline{\text{o}}$), S , D1 , D2 , ..., Dn
S , Moj (or EMi or MER)

D1, D2, ..., Dn will be stored in memory location but will not be dialed out.

R/P and */T keys can be stored as a digit in memory. In store mode, R/P is the pause function key.

The store mode can be released after the store function is executed or the state of the hook switch is changed.

2. S , D1 , D2 , ..., Dn , S , 0 , j
D1, D2, ..., Dn will be stored in memory location M0j and will not be dialed out.
3. OFFHOOK (or ON HOOK & $\overline{\text{HFI}} \overline{\text{i}} \underline{\text{o}}$), D1 , D2 , ..., Dn , S ,
S , Mn
 - a. D1, D2, ..., Dn will be stored in memory location and will be dialed out.
 - b. The S key must be pressed after completion of the dialing sequence.
4. D1 , D2 , ..., Dn , S , S , 0 , j
D1, D2, ..., Dn will be stored in memory location M0j and will be dialed out.

Repertory Dialing

- OFF HOOK (or ON HOOK & $\overline{\text{HFI}} \overline{\text{i}} \underline{\text{o}}$), Moj (or EMi or MER)

Access Pause

- OFF HOOK (or ON HOOK & $\overline{\text{HFI}} \overline{\text{i}} \underline{\text{o}}$), D1 , D2 , R/P , D3 , ..., Dn

1. The pause function can be stored in memory.
2. The pause function is executed in normal dialing, redialing, or memory dialing.
3. The pause function timing diagram is shown in Figure 5.



Pulse-to-Tone (* / T)

OFF HOOK (or ON HOOK & $\overline{\text{HFI}} \overline{\text{IO}}$), D1, D2, ..., Dn, * / T, D1', D2', ..., Dn'

1. If the mode switch is set to pulse mode, then the output signal will be:

D1, D2, ..., Dn, Pause (3.6s), D1', D2', ..., Dn'
(Pulse) (Tone)

2. If the mode switch is set to tone mode, then the output signal will be:

D1, D2, ..., Dn, *, D1', D2', ..., Dn'
(Tone) (Tone) (Tone)

3. The dialer remains in tone mode when the digits have been dialed out and can be reset to pulse mode only by going on-hook.

4. The P→T function timing diagram is shown in Figure 6.

5. * / T key cannot be stored as a digit in memory.

Save

1. OFF HOOK (or ON HOOK & $\overline{\text{HFI}} \overline{\text{IO}}$), S, D1, D2, ..., Dn, S, SAVE

D1, D2, ..., Dn, will be stored in SAVE memory but will not be dialed out.

2. OFFHOOK (or ON HOOK & $\overline{\text{HFI}} \overline{\text{IO}}$), D1, D2, ..., Dn, S, S, SAVE

D1, D2, ..., Dn, will be stored in SAVE memory and will be dialed out.

3. OFF HOOK (or ON HOOK & $\overline{\text{HFI}} \overline{\text{IO}}$), SAVE

The content of SAVE memory will be dialed out.

Flash (F = F1, F2, F3)

OFF HOOK (or ON HOOK & $\overline{\text{HFI}} \overline{\text{IO}}$), F

1. Flash key cannot be stored as a digit in memory and it has first priority among keyboard functions.

2. The system will return to the initial state after the break time is finished.

3. The flash function timing diagram is shown in Figure 7.



Clear key

1. , (or)
Redial and one-key redial buffer will be cleared.
2. ,
Location M0j buffer content will be cleared.
3. , ,
Location M0j buffer content will be cleared.

CHAIN DIALING

Relationship between the memory and the chain dialing buffer:

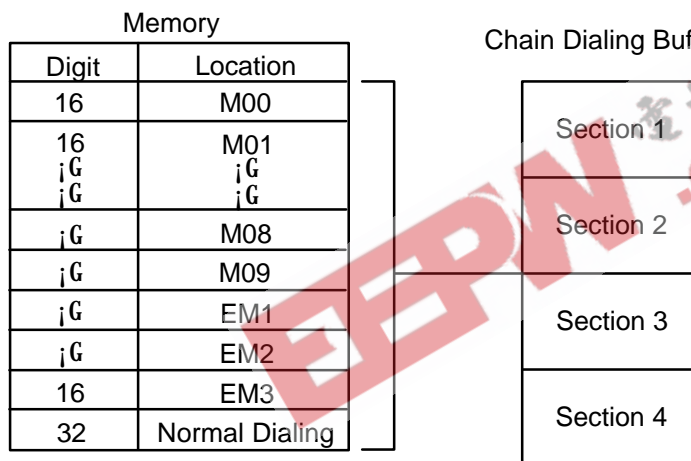

The chain dialing buffer may be divided into four sections, allowing up to four numbers to be dialed out in sequence. For example, if the user enters M01, M03, EM1, and normal dialing (manual dialing), the content of sections 1 to 4 will be M01, M03, EM1, and normal dialing (manual dialing). When numbers are entered into the chain dialing buffer, there is no need to wait until the previous dialing sequence has been completed. Numbers may be entered directly, one after the other, even while previous numbers are being dialed out.

1. ;
Redial buffer content = Manual dialing + Repertory dialing.
2. ;
Redial buffer content = Repertory dialing + Manual dialing.
3. ;
Redial buffer content = Repertory dialing + Repertory dialing.
4. ;
Redial buffer content = Redialing + Manual dialing.

W91473 SERIES



The primary redial content may not be manual dialing. Otherwise, the last redial content will be overwritten.

5. ;

Redial buffer content = Redialing + Repertory dialing.

Redialing is valid only as the first key-in after off-hook or after the handfree dialing function is toggled on.

The second sequence should not be performed until the first sequence is completely dialed out.

6. ;

Redial buffer content = Manual dialing.

The one-key redial may only be used after dialing out of a manual dialing sequence is completed.

7. ; ;

;

or

; ;

, , ,

M1 and M2 represent any of the repertory dialing memories.

The first redialing will dial out M1; the second will dial out M1, M2.

If dialing out of the repertory dialing memories has not been completed, the one-key redial key will be ignored.

Dialing of the second repertory dialing memory (M2) should not be performed until the one-key redialing operation is completed.

Notes:

Chain dialing (cascaded dialing) allows for memory or manual dialing while a previous dialing sequence is still being dialed out. More than one sequence of manual dialing is not permitted. Entering more than one manual dialing sequence will inhibit redialing. Chain dialing of more than four sections is not permitted.

; ; (two sections of manual dialing)

If more than four sections are entered, all sections after the fourth section will be ignored and redialing will be inhibited.

; ; ; ; (over 4 sections, ignore

and inhibit redial)

There is a 2.0 sec. inter-chain dialing pause for cascaded dialing.

W91473 SERIES



MERCURY DIALING

1. Up to 32 digits may be stored.
2. Mercury dialing is activated only as the first key-in after off-hook or handfree dialing is activated.
3. The timing diagram for the mercury memory function is given below.

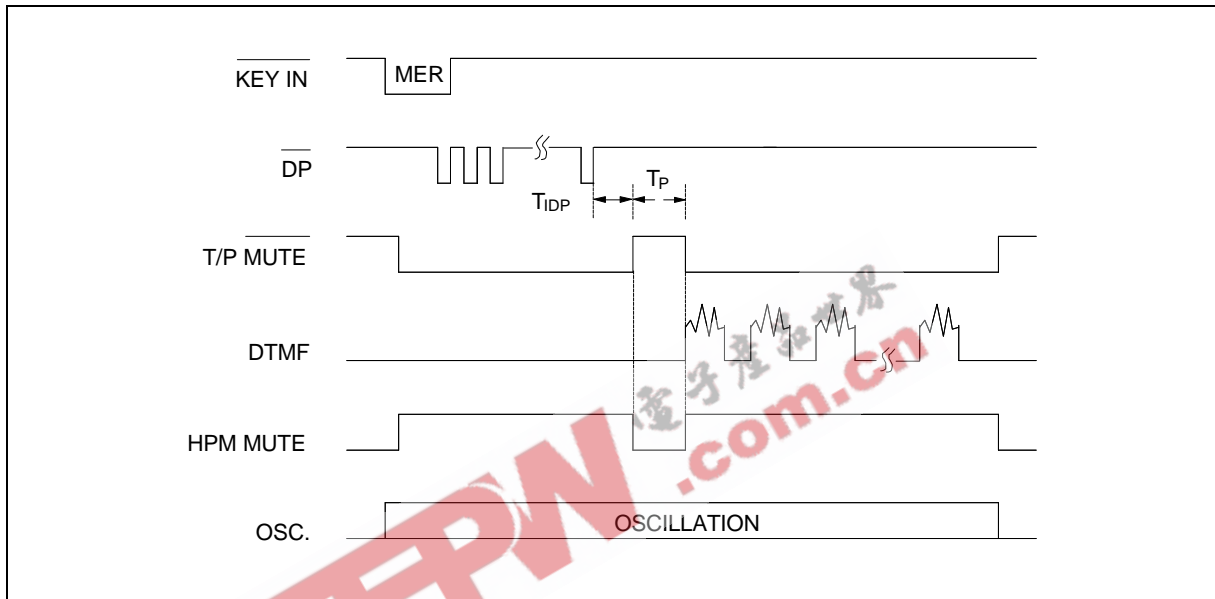

Mercury Function Timing Diagram

ABSOLUTE MAXIMUM RATINGS

PARAMETER	SYMBOL	RATING	UNIT
DC Supply Voltage	VDD-VSS	-0.3 to +7.0	V
Input/Output Voltage	V _{IL}	VSS -0.3	V
	V _{IH}	VDD +0.3	V
	V _{OL}	VSS -0.3	V
	V _{OH}	VDD +0.3	V
Power Dissipation	P _D	120	mW
Operating Temperature	T _{OPR}	-20 to +70	°C
Storage Temperature	T _{STG}	-55 to +125	°C

Note: Exposure to conditions beyond those listed under Absolute Maximum Ratings may adversely affect the life and reliability of the device.

W91473 SERIES



DC CHARACTERISTICS

(V_{DD}-V_{SS} = 2.5V, F_{osc} = 3.58 MHz, T_a = 25° C, all outputs unloaded)

PARAMETER	SYMBOL	CONDITIONS	MIN.	TYP.	MAX.	UNIT
Operating Voltage	V _{DD}		2.0	-	5.5	V
Operating Current	I _{OP}	Tone	-	0.3	0.5	mA
		Pulse	-	0.15	0.3	
Standby Current	ISR	HKS = 0, No load & No key entry	-	-	15	μA
Memory Retention Current	IMR	HKS = 1, V _{DD} = 1.0V	-	-	0.2	μA
DTMF Output Voltage	V _{TO}	Row group, R _L = 5 KΩ	130	150	170	V _{rmS}
Pre-emphasis	-	Col/Row, V _{DD} = 2.0 to 5.5V	1	2	3	dB
DTMF Distortion	THD	R _L = 5 KΩ, V _{DD} = 2.0 to 5.5V	-	-30	-23	dB
DTMF Output DC Level	V _{TDC}	R _L = 5 KΩ, V _{DD} = 2.0 to 5.5V	1.0	-	3.0	V
DTMF Output Sink Current	I _{TL}	V _{TO} = 0.5V	0.2	-	-	mA
DP Output Sink Current	I _{PL}	V _{PO} = 0.5V	0.5	-	-	mA
T/P MTUE Output Sink Current	I _{MI}	V _{MO} = 0.5V	0.5	-	-	mA
HPM MUTE Output Sink Current	I _{HPMI}	V _{TO} = 0.5V	0.5	-	-	mA
HPM MUTE Output drive Current	I _{HPMH}	V _{TH} = 2.0V	0.5	-	-	mA
HKS I/P Pull-high Resistor	R _{KH}		-	300	-	KΩ
Key Tone Output Current	I _{KTH}	V _{KTH} = 2.0V	0.5	-	-	mA
	I _{KTL}	V _{KTH} = 0.5V	0.5	-	-	
HFO Drive/Sink Current	I _{HFH}	V _{HFH} = 2.0V	0.5	-	-	mA
	I _{HFL}	V _{HFL} = 0.5	0.5	-	-	
Keypad Input Drive Current	I _{KD}	V _I = 0V	30	-	-	μA
Keypad Input Sink Current	I _{KS}	V _I = 2.5V	200	400	-	μA
Keypad Resistance			-	-	5.0	KΩ

W91473 SERIES



AC CHARACTERISTICS

PARAMETER	SYMBOL	CONDITIONS	MIN.	TYP.	MAX.	UNIT
Keypad Active in Debounce	TKID	-	-	20	-	mS
Key Release Debounce	TKRD	-	-	20	-	mS
Pre-digit Pause ¹	TPDP1 10 ppS	M/B = 2/3	-	40	-	mS
		M/B = 1/2	-	33.3	-	
Pre-digit Pause ²	TPDP2 20 ppS	M/B = 2/3	-	20	-	mS
		M/B = 1/2	-	16.7	-	
Interdigit Pause (Auto dialing)	TIDP	10 ppS	-	800	-	mS
		20 ppS	-	500	-	
Make/Break Ratio	M/B	M/B = 2/3	-	40:60	-	%
		M/B = 1/2	-	33:67	-	
Tone Output Duration	TTD	Auto Dialing	-	93	-	mS
Intertone Pause	TITP	Auto Dialing	-	93	-	mS
Flash Break Time	TFB	-	-	98	-	mS
			-	305	-	
			-	600	-	
Pause Time	TP	-	-	3.6	-	S
Key Tone Frequency	FKT	-	-	600	-	Hz
Key Tone Duration	TKTD	-	-	35	-	mS
One-key Redialing Pause Time	TPR	-	-	600	-	mS
One-key Redialing Break Time	TRB	-	-	2.2	-	S
First key-in Pause Time	TFKP	-	-	600	-	mS

Notes:

- Crystal parameters suggested for proper operation are $R_s < 100\Omega$, $L_m = 96 \text{ mH}$, $C_m = 0.02 \text{ pF}$, $C_n = 5 \text{ pF}$, $C_l = 18 \text{ pF}$, $F_{osc} = 3.579545 \text{ MHz} \pm 0.02\%$.
- Crystal oscillator accuracy directly affects these times.

TIMING WAVEFORMS

W91473 SERIES

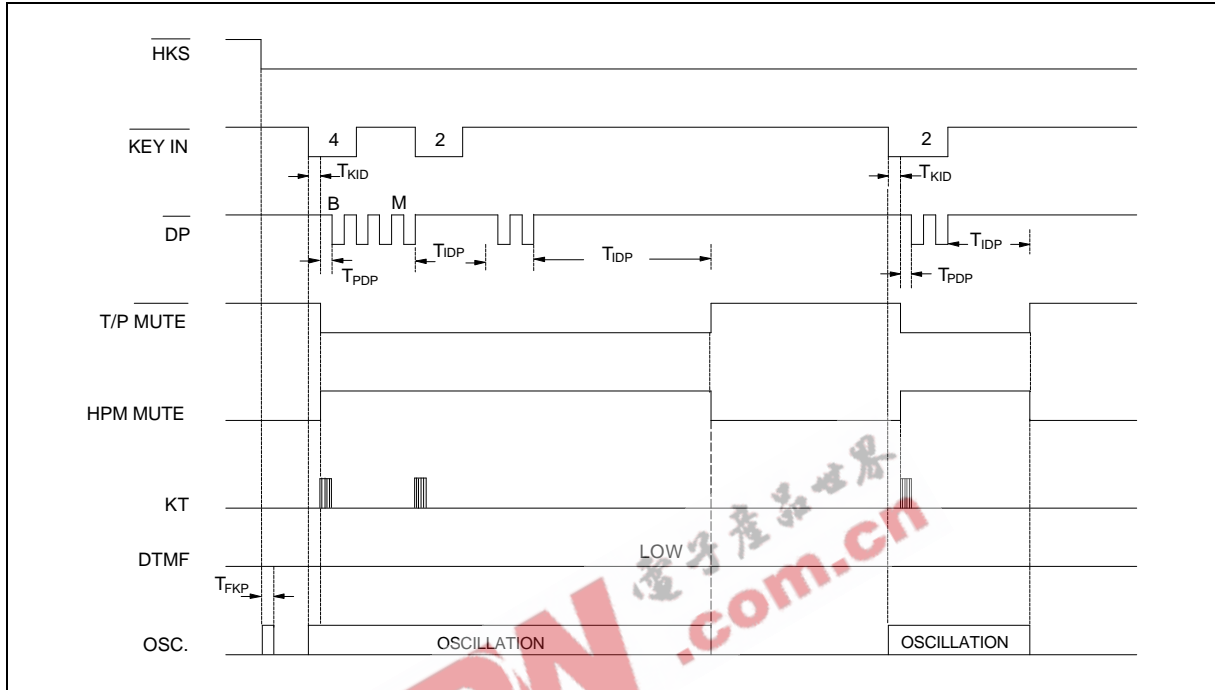

Figure 1. Pulse Mode Diagram (Normal Dialing)

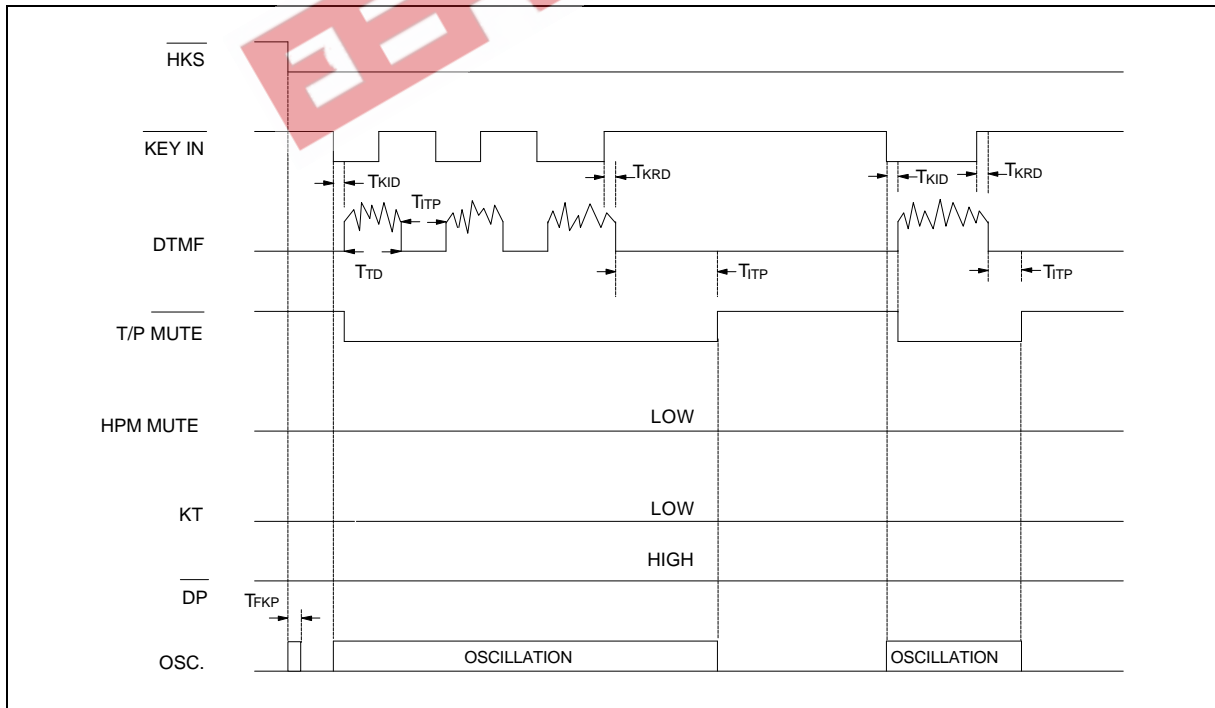

Figure 2. Tone Mode Diagram (Normal Dialing)

Timing waveforms, continued

W91473 SERIES

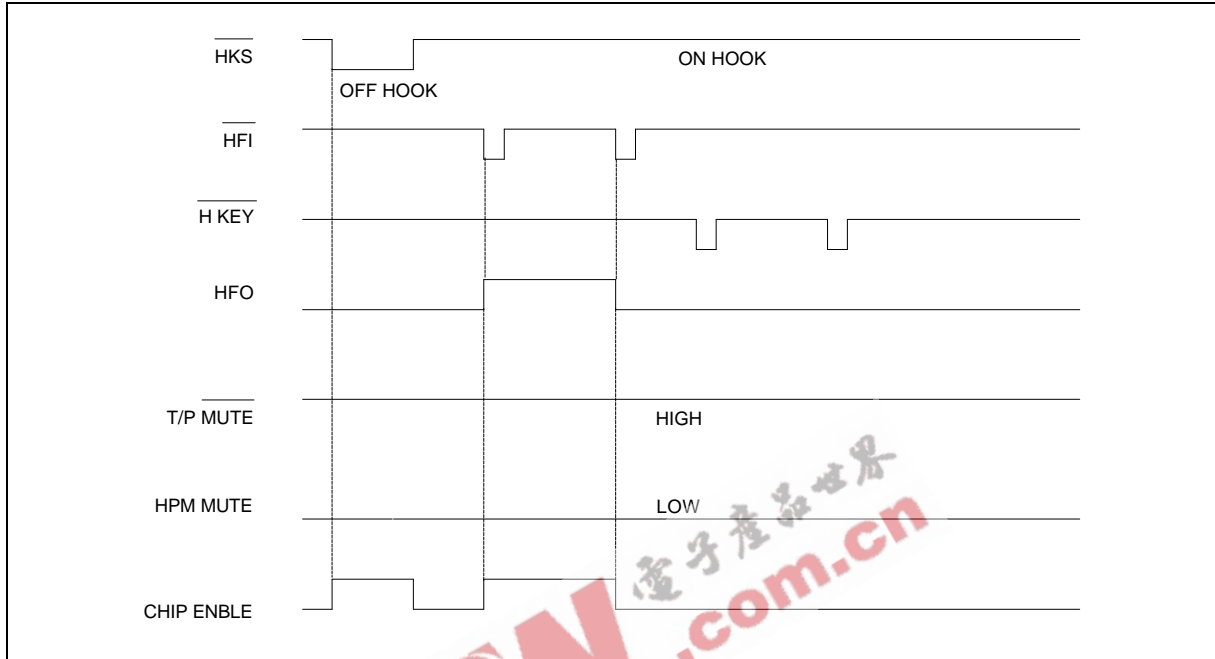

Figure 3(a).

Note: The H KEY cannot be enabled when chip is disabled.

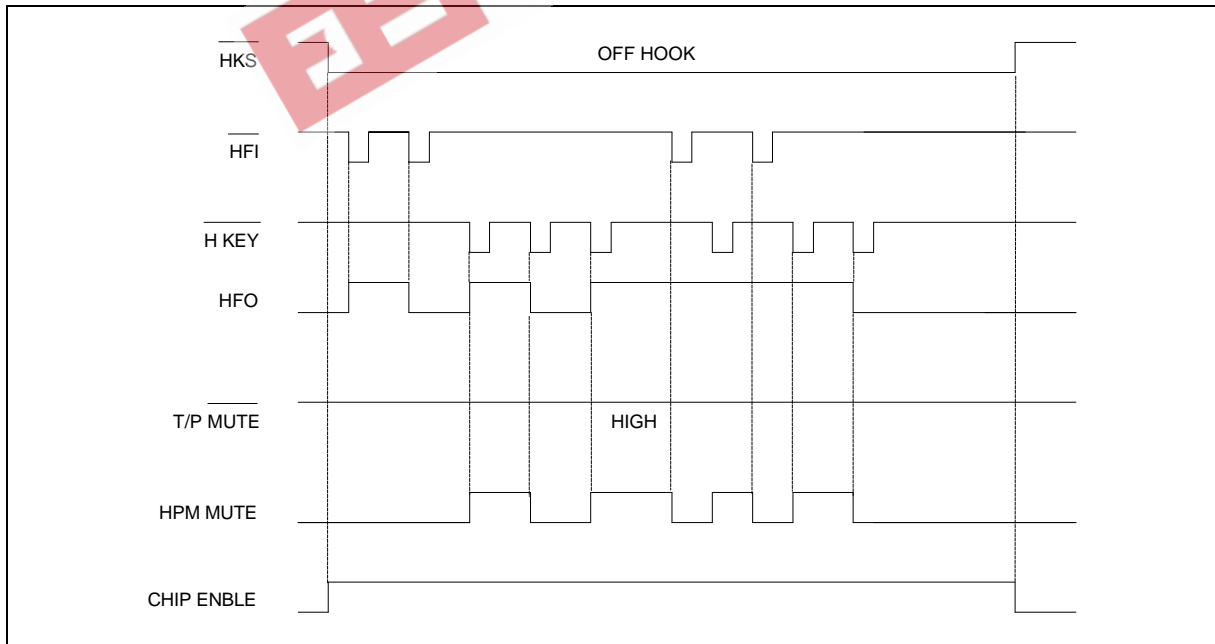

Figure 3(b).

Note: The HFI and H KEY inputs will toggle the HFO signal; as soon as either HFI or H KEY is activated, the HFO signal will go high and previous inputs will be ignored.

W91473 SERIES



Timing waveforms, continued

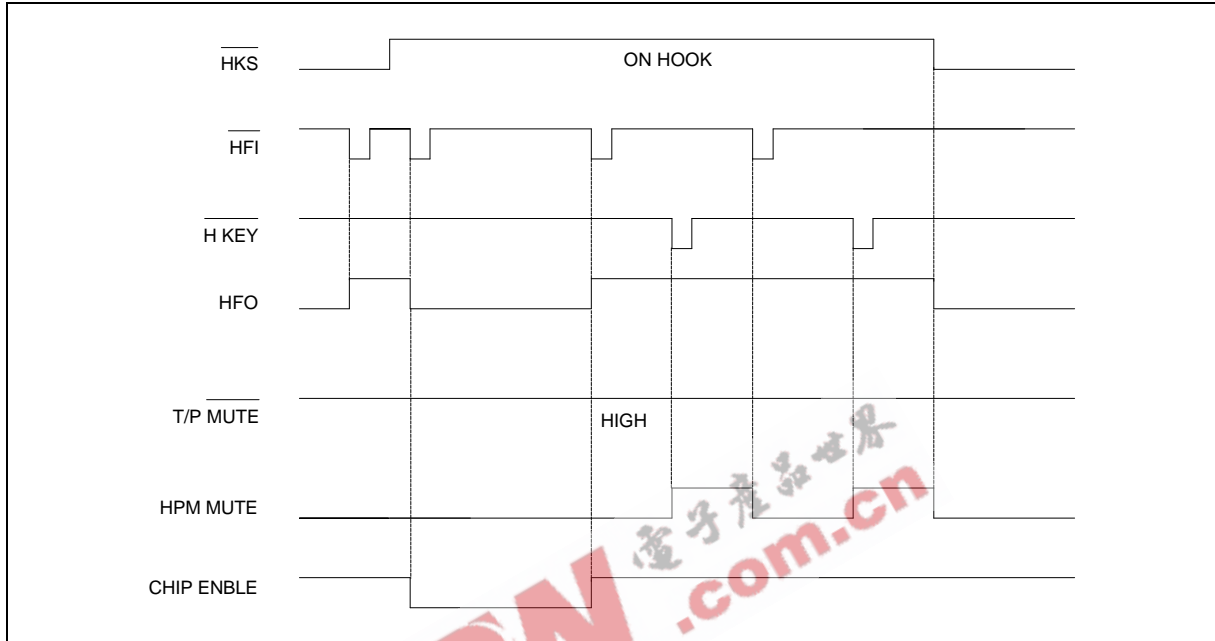

Figure 3(c).

Note: Changing the state of the HKS signal from high to low will initialize the HFO and HPM MUTE signals.

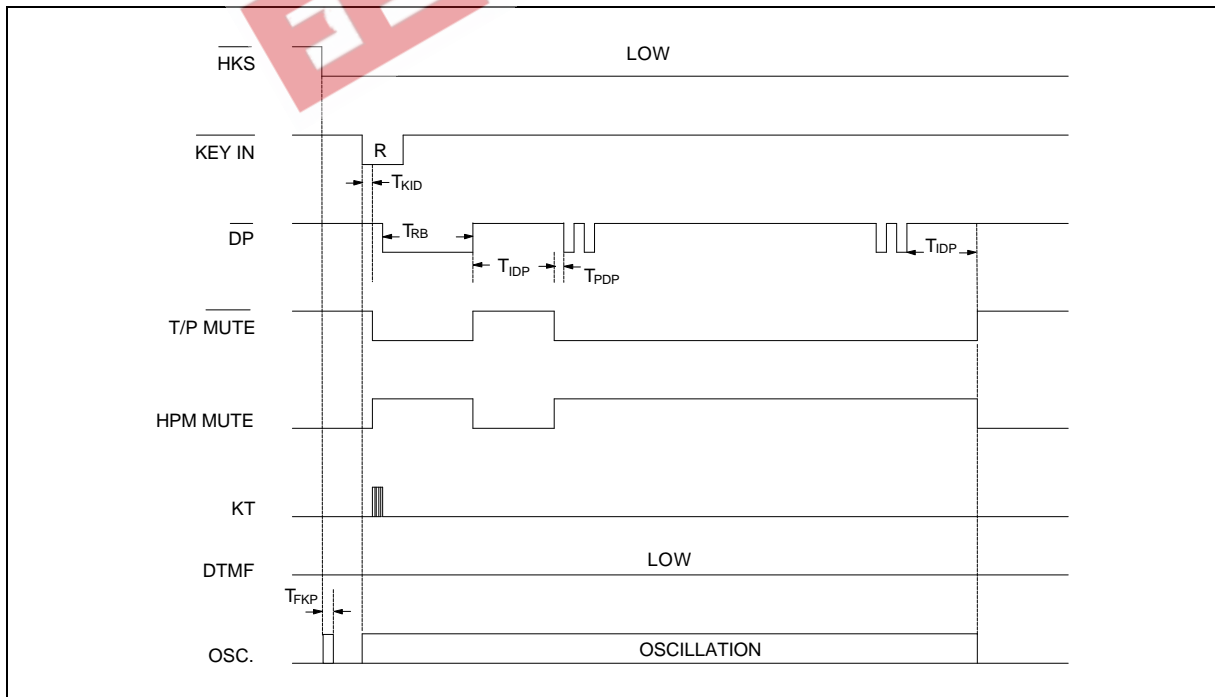

Figure 4. Pulse Mode One-key Redialing Timing Diagram (when not first key)

W91473 SERIES



Timing waveforms, continued

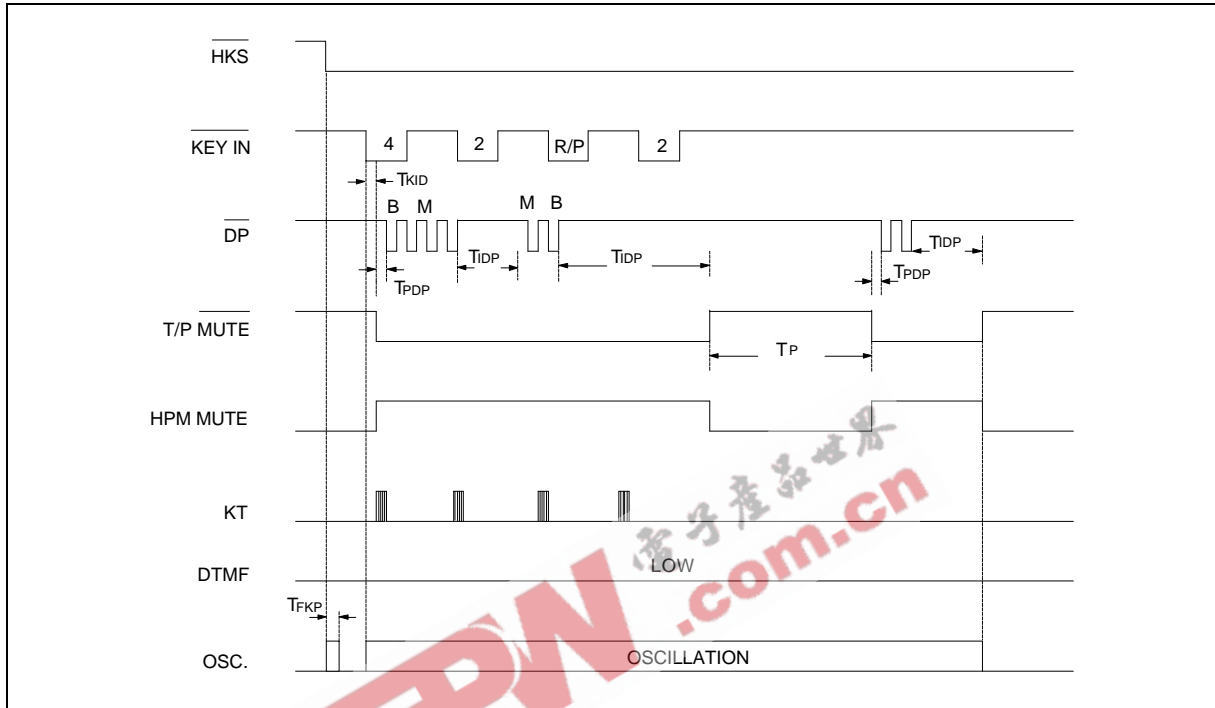

Figure 5. Pause Function Timing Diagram

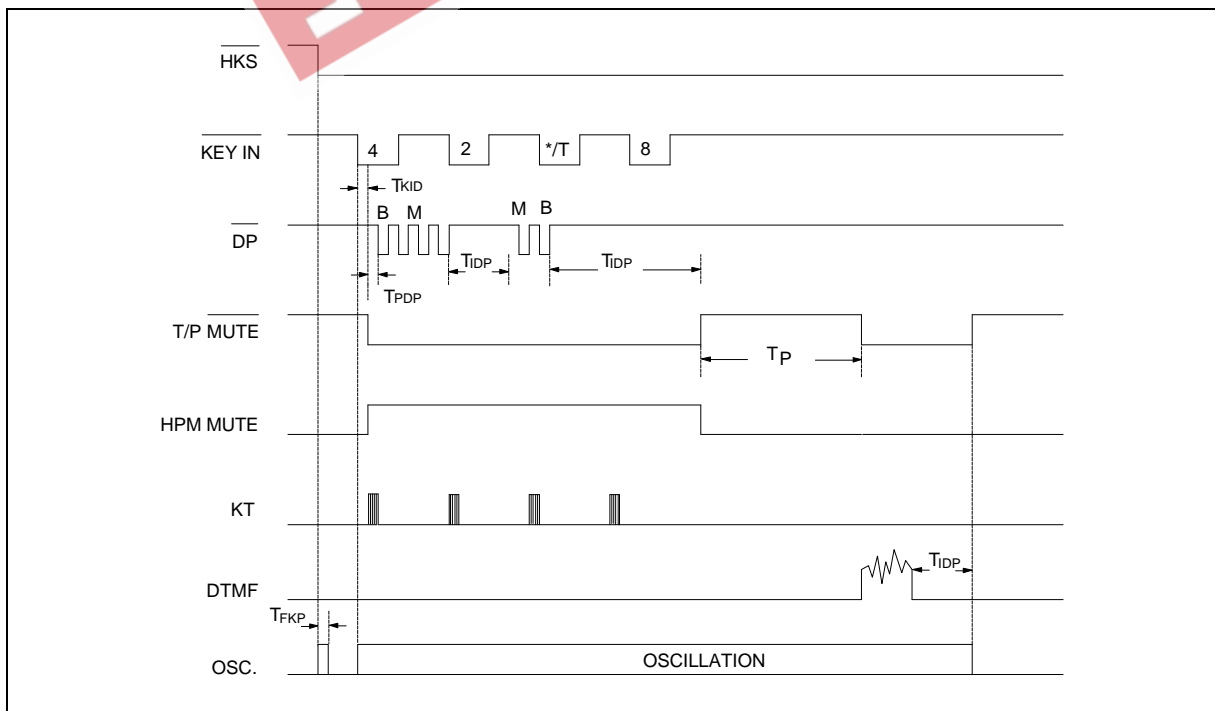

Figure 6. Pulse-to-Tone Function Timing Diagram

W91473 SERIES



Timing waveforms, continued

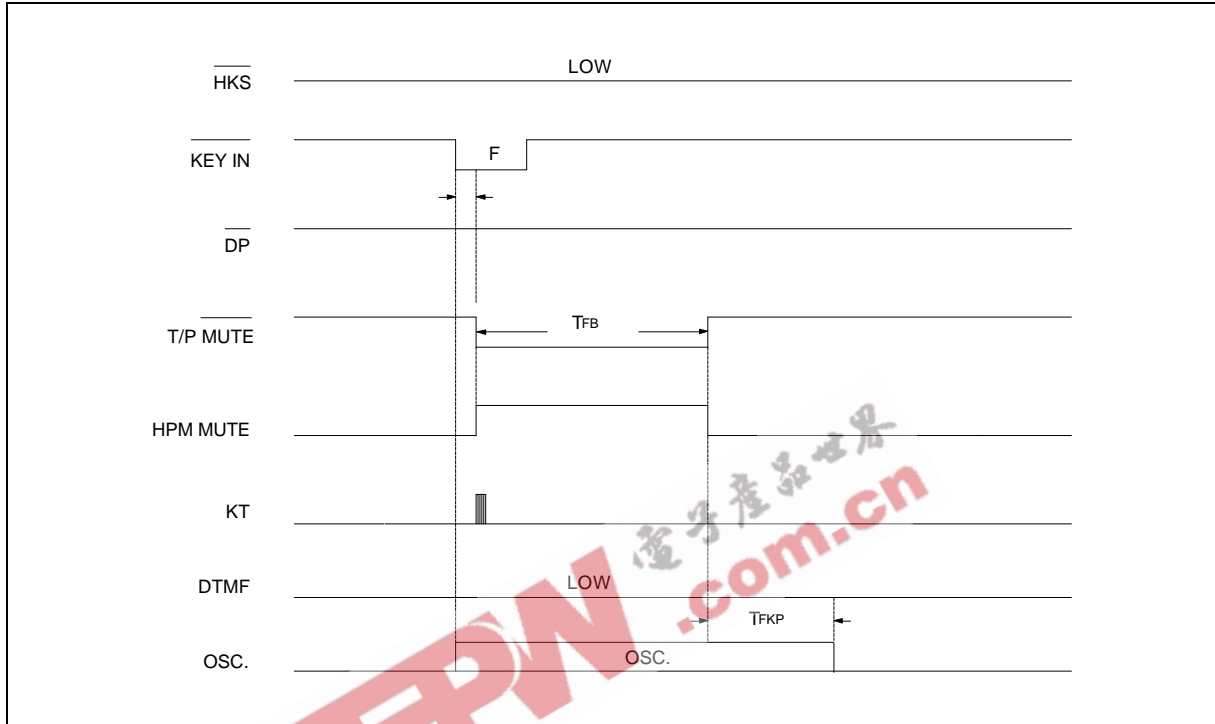

Figure 7. Flash Operation Timing Diagram

W91473 SERIES



EEPW 电子產品世界
.com.cn



Headquarters

No. 4, Creation Rd. III,
Science-Based Industrial Park,
Hsinchu, Taiwan
TEL: 886-3-5770066
FAX: 886-3-5792697
<http://www.winbond.com.tw/>
Voice & Fax-on-demand: 886-2-7197006

Taipei Office

11F, No. 115, Sec. 3, Min-Sheng East Rd.,
Taipei, Taiwan
TEL: 886-2-7190505
FAX: 886-2-7197502

Winbond Electronics (H.K.) Ltd.

Rm. 803, World Trade Square, Tower II,
123 Hoi Bun Rd., Kwun Tong,
Kowloon, Hong Kong
TEL: 852-27516023
FAX: 852-27552064

Winbond Electronics North America Corp.

Winbond Memory Lab.
Winbond Microelectronics Corp.
Winbond Systems Lab.

2730 Orchard Parkway, San Jose,
CA 95134, U.S.A.
TEL: 1-408-9436666
FAX: 1-408-9436668

Note: All data and specifications are subject to change without notice.