

Surface Mount Switching Diode

SWITCHING DIODE
100m AMPERRES
80 VOLTS

Features:

- * Low Current Leakage
- * Low Forward Voltage
- * Ultra High Speed Switching
- * Surface Mount Package Ideally Suited for Automatic Insertion

Mechanical Data:

- * Case: SOT-323, Molded Plastic
- * Terminal: Solderable per MIL-STD-202 Method 208
- * Polarity: See Diagram
- * Weight: 0.006 grams(approx)

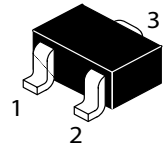

SOT-323(SC-70)

SOT-323 Package Outline Dimensions

Unit:mm

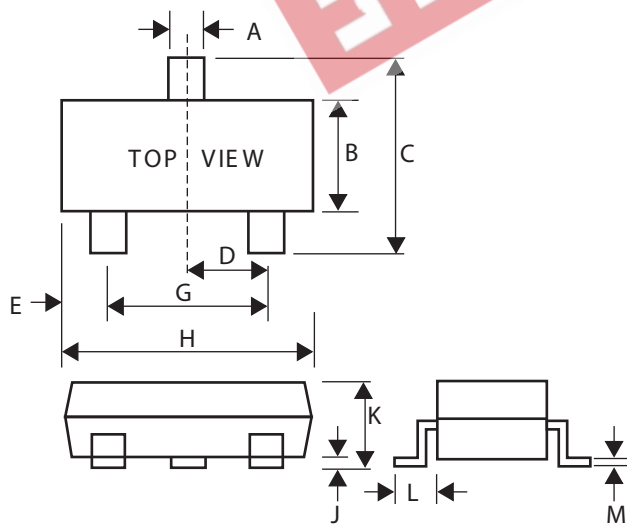

SOT-323		
Dim	Min	Max
A	0.30	0.40
B	1.15	1.35
C	2.00	2.40
D	-	0.65
E	0.30	0.40
G	1.20	1.40
H	1.80	2.20
J	0.00	0.10
K	0.80	1.00
L	0.42	0.53
M	0.10	0.25

Maximum Ratings (EACH DIODE)

Characteristic	Symbol	WAN202U	WANP202U	WAN217U	Unit
Reverse Voltage	V_R	80			Volts
Forward Current	I_F	100			mAdc
Peak Forward Surge Current	I_{FM}	300			mAdc

Thermal Characteristics

Characteristic	Symbol	Max	Unit
Total Device Dissipation FR-5 Board *1, $T_A=25^\circ\text{C}$ Derate Above 25°C	PD	200 1.6	mW mW/ $^\circ\text{C}$
Thermal Resistance Junction to Ambient	$R_{\theta JA}$	625	$^\circ\text{C/W}$
Junction and Storage Temperature	T_J, T_{stg}	-55 to + 150	$^\circ\text{C}$

*1 ER-5=1.0x0.75x0.062 in

Electrical Characteristics ($T_A=25^\circ\text{C}$ Unless Otherwise Note) (Each Diode)

Characteristic	Symbol	Min	Max	Unit
Reverse Breakdown Voltage ($I_{BR}=100\ \mu\text{Adc}$)	V_{BR}	80		Vdc
Reverse Voltage Leakage Current $V_R=70\text{V}$	I_R		0.1	μAdc
Diode Capacitance ($V_R=6\text{Vdc}$, $f=1.0\text{MHz}$)	C_D		3.5	PF
Forward Voltage ($I_F=100\ \text{mAdc}$)	V_F		1.2	Vdc
Reverse Recovery Time (Figure 1.) $I_R=5.0\ \text{mAdc}$, $V_R=6.0\ \text{Vdc}$	t_{rr}		4.0	nS

Device Marking

Item	Marking	Equivalent Circuit diagram
WAN202U	A4	
WAP202U	A1	
WAN217U	A7	

FIG 1. Recovery Time Equivalent Test Circuit

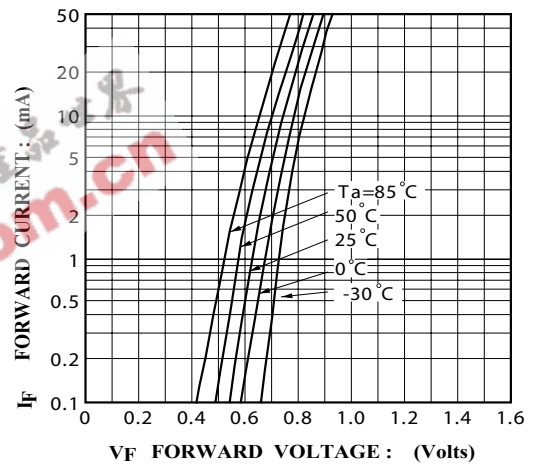
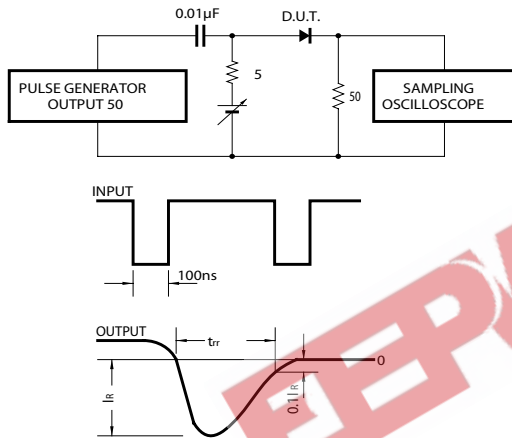

FIG.2 Forward characteristics

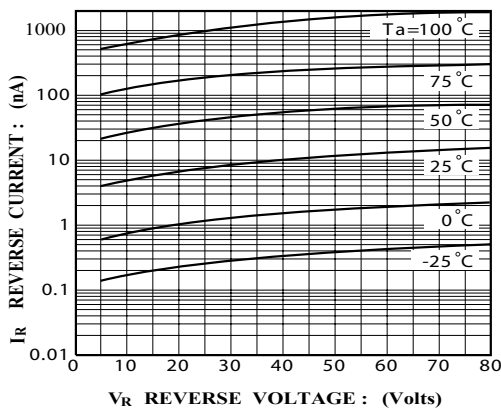

FIG.3 Reverse characteristics

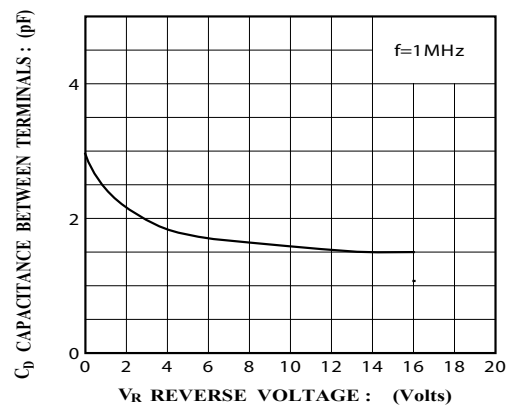

FIG.4 Capacitance